

Evaluation of Biogas Sanitation Systems in Nepalese Prisons

C. Lohri*, Y. Vögeli*, A. Oppliger**, R. Mardini**, A. Giusti**, C. Zurbrügg*⁺

*Eawag, Swiss Federal Institute of Aquatic Science and Technology, 8600 Dübendorf, Switzerland; Department of Water and Sanitation in Developing Countries (Sandec)

(Email: yvonne.voegeli@eawag.ch)

**ICRC, International Committee of the Red Cross, Water and Habitat Unit, 19 avenue de la Paix, 1202 Geneva, Switzerland

(Email: rmardini@icrc.org)

⁺ presenting author: Christian Zurbrügg, zurbrugg@eawag.ch

Abstract

In 2007, with the help of the International Committee of the Red Cross (ICRC), biogas sanitation systems were installed in three Nepalese District Jails to improve the poor sanitary conditions, reduce the health risks of the detainees, and provide a smoke-free source of cooking fuel. After one year of operation the functionality of these new systems was assessed and their impact and acceptance evaluated. The study was conducted between April and June 2009. Based on findings of a first assessment, repairs and user trainings were conducted. Further monitoring results were obtained during a third visit, when the facilities were considered to be running under optimal conditions. All five fixed-dome digesters (sizes of 10m³, 20m³ and 35m³) revealed gastight domes and showed high process stability with no accumulation of inhibitory substances. Average gas production from human waste exclusively are 28NL/person/day, and with addition of kitchen waste feedstock 62NL/person/day. Methane fraction varied between 57 and 78 Vol-%, depending on the feedstock. Hydraulic retention time was between 13 and 32 days which was far below the planned 70 days. This was due to the use of 3L of water per flush rather than the 1L planned. Pathogen analyses of effluent in the storage pits revealed E. Coli concentration to be acceptable for restricted irrigation (<10⁵ CFU/100ml). The vast majority (98%) of detainees favors the digesters and reports a general improvement of living conditions. Given the use of biogas for cooking, 59% of the interviewed inmates appreciated less smoke in the kitchen (and thus less respiratory health problems) and 49% mentioned the improved sanitary and hygienic conditions. Up to 41% of the money previously spent for conventional cooking fuel could be saved thanks to the use of biogas. Suggested improvements include a better design and slope of the inlet pipes, a buffer wall to increase the retention time, and an improved maintenance strategy.

Keywords

Anaerobic digestion; prison sanitation, institutional waste management, decentralized blackwater treatment

INTRODUCTION

The armed conflict between Maoist armed opposition and government forces in the period of 1996-2006 led to increased number of detainees in Nepalese prisons. Severely overcrowded jails and existing old infrastructures led to very poor water, sanitation and environmental conditions harshly affecting the detainees. To mitigate this situation the International Committee of the Red Cross (ICRC) decided to support the prison authorities with technical expertise and assistance to ensure that detainees have access to improved infrastructure, such as water supply and sanitation. The Water and Habitat unit of ICRC initiated a biogas programme with the following aims:

- To improve waste water treatment of the prisons (to reduce health risk of the detainees).
- To provide a renewable energy source to the jails to reduce the use of traditional fuels (wood and kerosene) and to improve the kitchen environment (reduction of indoor air pollution).
- To use the biogas slurry as fertilizer.
- To promote construction of biogas plants on institutional level for other prisons.

In January 2007, an agreement between ICRC and the local expert partner “Biogas Sector Partnership Nepal (BSP-N)” was signed to implement five biogas sanitation systems in three District Jails in Nepal. By May 2008, the construction of all systems was completed. To assess the efficiency and sustainability of the said projects after one year in operation, ICRC joined in partnership with Eawag/Sandec to conduct an independent evaluation. This included assessment of construction, operation and maintenance aspects as well as an evaluation of the impact of the biogas systems on the environment and their acceptance by the users and beneficiaries.

DESIGN OF BIOGAS SANITATION SYSTEMS AND OPERATIONAL SET-UP

The Nepal biogas plant design promoted under BSP-N is the modified GGC2047 model, which originates in its shape from a Chinese type fixed dome digester. The five digesters installed have the size of 3x 10m³, 1x 20m³ and 1x 35m³. The number of prison detainees is 100 in the smallest and 270 in the biggest prison, with all three prisons having a small separate female section.

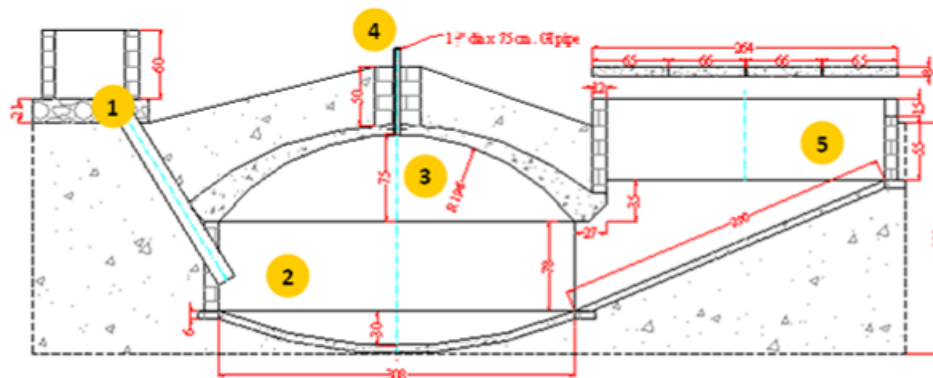

Figure 1. Blueprint of a 10m³ biogas digester model GGC2047. 1) Inlet chamber with inlet pipe; 2) Digester; 3) Dome (gas storage); 4) Gas outlet; 5) Compensation / expansion chamber with overflow-point (BSP-N, 2008)

While the toilets of the detainees as well as the prison kitchen with its biogas stoves are located within the prison walls, the digester and effluent pits are situated outside the prison perimeter and thus not accessible for the inmates. Feeding chambers for kitchen waste were either built inside or outside the internal prison perimeter. Contrary to most western jails, the security staff & wardens do not undertake any tasks inside the prison walls and are located in the external security perimeter. The prisoners organize themselves for preparing meals (in groups or individually) and are only allowed to leave the internal security perimeter for assigned tasks with special permission of the “chaukidar” (leader of the detainees). Usually one assigned detainee is responsible for the kitchen waste management and gets a monthly salary from the other inmates for this task. Kitchen waste is added to three out of five digesters to enhance gas production. In the case of the other two digesters, the organic waste is sold to pig farmers.

METHODOLOGY

The study is based on an assessment covering a period of three months from April to June 2009, during which a detailed monitoring program was conducted. Three monitoring cycles were executed, each cycle consisting of a consecutive four-day visit to all three jails.

- 1st visit: Situation analysis, testing of equipment and methods.
- 2nd visit: Repair work and user training (under guidance of ICRC) were carried out. A set of spare-parts was handed over to the jail authorities and interviews with detainees were conducted.
- 3rd visit: Sampling and analyses of performance

Sampling and analyses were conducted during each of the three visits to register the changes before and after repairs, as well as operational adaptations and climatic variations. The last set of data is based on the results generated on the last visit and reflects optimal operating conditions after repairs and adaptations. The parameters monitored are:

Parameters measured on-site. Temperature, pH, electrical conductivity (EC) and Redox potential of effluent were measured by using a HQ40d (Hach-Lange) apparatus. COD, NH₄-N, Total N and Total P were analysed using a Thermoblock Nanocolor Vario compact (Macherey-Nagel) and a mobile photometer Lasa20 (Hach-Lange). To assess process stability, A/TIC analyses were conducted on effluent samples, applying the titration method according to Kapp. E.Coli content of influent and effluent was analysed as one parameter for pathogen reduction using 3M Petrifilm tests.

Parameters analysed off-site in laboratories. Effluent samples were given to Kathmandu University to analyze Total Solids (TS) and Volatile Solids (VS). Additionally, effluent samples were taken during the first visit and sent to the Swiss Tropical Institute (STI) in Basel, Switzerland to analyze occurrence of helminth eggs as another indicator microorganism for pathogens.

Interviews. Users of the biogas sanitation systems were interviewed with the help of local translators to generate various information regarding operation, convenience and acceptance of the plants.

RESULTS AND EVALUATION

Following the first monitoring cycle, repair work was necessary to guarantee best possible operation of the system. Subsequently, observation, sampling and analysis showed the following results:

Technical aspects and process stability

Testing the maximum gas pressure of the domes, it could be established that all five digester domes were gastight. This indicates good workmanship during construction of the domes and use of reasonable quality materials. Regarding the piping, pressure tests indicated the pipes to be gastight, except for one facility. However, the gas pipes of three systems are partly exposed (uncovered). This presents a risk of tripping over the pipes or other damages which could then lead to leakages. Furthermore, two gas pipe lines are equipped with more elbows than necessary, thus needlessly reducing the gas pressure in both kitchens. Sufficient slope (5-7%) between toilets and digester is essential to avoid blockages. Yet this not only applies for the overall slope, but also for each section between the inspection chambers. In this regard, workmanship in one prison was poor, which led to frequent blockages. Since the implementation in this prison, these inlet pipes with insufficient slope have blocked four times. Overflowing toilets, cumbersome repairs, and aversion of the detainees responsible for repairs are some negative consequences of these problems.

Regarding process stability, all five digesters showed good characteristics (pH: 7.1 - 7.4, temperature: 26-30°C, Redox: -380mV) and are not likely to acidify or standstill due to accumulation of inhibitory substances (VFA, NH₄-N).

Feedstock

The feedstock of the biogas plants in the prisons is composed of human faeces and to some extent also of kitchen waste.

Human faeces. The average daily amount of human waste excreted per adult person in Nepal is 0.4 kg (Karki et al., 2005). Average use of water for flushing, anal cleansing and cleaning of toilet area was observed to be between 2 and 4L. Representative samples of water diluted human waste which enter the biogas systems were taken at two facilities by temporarily blocking the inspection chamber, stirring and mixing the contents and then extracting a sample. As the Nepalese diet does not vary essentially throughout the country, the results are considered to be representative for the other jails. The average results of diluted human waste inputs are:

Total Solids (TS): 34.3 g/L (3.4 % of wet weight)
 Volatile Solids (VS): 28.4 g/L (82.8 % of TS)
 Chemical Oxygen Demand (COD): 36.4 g/L
 Total Nitrogen (N tot): 3.7 g/L
 Total Phosphorus (P tot): 325mg/L
 Carbon/Nitrogen ratio (C/N): 13.67g/L / 3.68g/L -> 3.7

Kitchen waste. As mentioned above, kitchen waste was only added to 3 out of 5 digesters . The amount added varied considerably between 3 kg/d and 45 kg/d in the different digesters.

Gas production, composition and use

Gas production. The average gas production from using only human waste as feedstock was 28NL/person/day. With additional feedstock of the entire kitchen waste (in one prison), the gas production showed to increase considerably up to 62NL/person/day. When comparing the measured gas production with the computed gas production based on the design, the actual gas production in four out of the five digesters showed to be higher than previously estimated. These differences of expected and measured gas output can be explained by the indicators listed in Table 1 which show differences in actual number of detainees and amount of kitchen waste input compared to the initially expected values.

Table 1. Gas production (Pre-construction computation and measurements)

		Jail 1 10m3	Jail 1 20m3	Jail 2 10m3	Jail 2 35m3	Jail 3 10m3
<i>Expected number of detainees [pers.]</i>	2007	68	119	115	206	74
Observed number of detainees [pers.]	April - June 2009	65	135	115	155	106
<i>Expected kitchen waste feeding [kg/d]</i>	2007	4	43	0	73	0
Observed kitchen waste feeding [kg/d]	April - June 2009	3	45	0	3	0
<i>Expected gas production [L/d]</i>	2007	2'000	4'000	3'000	7'000	2'000
Measured gas production [L/d]	June 2009	2'120	9'210	3'310	4'800	3'450
Difference between expected and measured gas production [%]		+6%	+130%	+10%	-31%	+73%
Daily gas production per person [NL/pers./d]	June 2009	29.5	61.9	25.9	27.9	29.2
Gas burning period [h/d]	June 2009	6.5	19.5	9	10.5	9.5

Gas composition. As expected, gas composition analysis revealed high methane content (> 70 Vol-%) in systems where only human waste is used as feedstock. In facilities where kitchen waste was added as feedstock (rich in carbohydrates), a substantial increase in the gas production was observed, at the same time lowering the methane content, as the undigested kitchen waste releases high quantities of CO₂. The content of oxygen (O₂) in biogas of all digesters was measured to be 0 Vol-%. The share of ammonia (NH₃, >200ppm) and hydrogen sulfide (H₂S, >1000ppm) exceeded the range of the gas composition measuring gauge. The main fractions of other gases such as water vapour and nitrogen gas could not be measured.

Gas use pattern / burning duration. The study showed that the use of biogas is suitable for cases with strictly regulated cooking in large groups (with up to 15 persons) as well as for unregulated individual use by numerous detainees. The most important advice for the detainees is to fully consume all the gas produced per day. This is advisable to avoid losses due to insufficient gas storage capacity and to reduce spending on conventional cooking fuels. Some prison sections

showed some difficulties to follow this advice given the way the cooking is organized. In such cases, it would be helpful to provide an additional stove to achieve complete gas consumption. The experiments showed that ten hours of cooking on a biogas stove requires an average of 4027L of gas. This is in line with the expected consumption rate (400L/h) of the stove-design (BSP-N, 2008).

Treatment efficiency

The TS, VS and COD content of the effluent serves as good indication of the treatment efficiency: The lower the concentration, the more efficient the performance of the biogas facility. The effluent was observed as very liquid slurry with a low TS content of about 4g/L. The share of organic matter is rather low with VS between 24 and 44% and a COD content of around 500 mg/L, which indicates a satisfactory efficiency of the system.

Analyses of effluent in the storage pits revealed E.Coli concentrations acceptable for restricted irrigation according to the WHO guidelines on the safe use of waste water (WHO, 2006). In some cases however, Helminth eggs, as a further indicator organism, were not completely eliminated by anaerobic digestion and sedimentation processes.

Use of effluent

The effluent (also called slurry or bio-slurry) was not used as fertilizer in any of the three monitored jails. The reasons are related to local circumstances and mental restraints:

- The location of slurry exit and storage is located outside the prison walls where detainees have no access.
- The area around the biogas facilities, although used for agriculture, is also part of the external prison perimeter and thus not accessible for the detainees.
- The security forces and wardens which cultivate crops (mostly maize in the external prison perimeter) reject the use of treated faecal matter in general, and in particular as it represents waste of the prisoners.
- The security forces and wardens currently do not use any (organic or chemical) fertilizer for their crops as they do not see any necessity for it.

The undiluted application of the effluent may damage certain crops due to the high osmotic pressure. Requirements for the specific crops cultivated need to be further evaluated. A possible solution would be to dilute the effluent with water in a 1:1 or 1:2 ratio before application for irrigation.

Economic aspects

Economic benefits are directly influenced by the amount of biogas produced, which replaces other cooking fuel, as well as the savings on money previously spent for septic tank emptying. These figures differ for each jail. In jail 1, where kitchen waste is added to the digesters as recommended, 41% of the money previously spent for conventional cooking fuel is saved due to biogas substitution. In jail 2 and 3, savings of 17% and 22% respectively have been reported since the installation of the biogas system.

Table 2. Approximate paying off period for each jail

	Jail 1 (2 systems)	Jail 2 (2 systems)	Jail 3 (1 system)
Savings of cooking fuel [NR/prison/year]	29'400	84'000	41'100
Savings of septic tank emptying [NR/year]	46'000	22'000	2'200
Cost of biogas system [NR]	511'000	577'000	160'000
Approximate paying off period [year]	1.5	5.4	3.7

Socio-cultural aspects / acceptance

In principle, the biogas systems are favourably perceived by the vast majority of detainees who reported a general improvement of living conditions. Of the interviewed inmates 59% indicated reduced smoke in the kitchen (and thus less respiratory health problems) and 49% mentioned improved sanitary and hygienic conditions.

In one jail quick acceptance of biogas was reported, in two other jails detainees expressed their initial skepticism towards a system which transforms human faeces into cooking fuel. These detainees admitted having feared transmission of diseases through biogas and a worse taste of the food. However, after no such negative changes were observed or reported, they cautiously tried out biogas-cooked food themselves. It can be thus be concluded that experiencing no negative effects after consuming “biogas-food” and the prospect of saving a decent share of the daily allowances led to a change of perception.

RECOMMENDATIONS

Regarding the digester design, no compelling reasons were found for major corrections on the modified GGC2047 design. The system with underground fixed-dome digesters, compensation chambers and overflow point is well established and appropriate for the Nepalese context. Careful attention should be paid to comply with the standard dimensions, e.g. sufficient slope of inlet pipe, gradient for effluent drain-off and backfilling of soil.

With regards to operational aspects, kitchen waste management needs to be examined carefully before dimensioning a biogas system and detainees should be convinced of the benefits of additional organic waste feeding into the digester. The organization of anticipated kitchen waste feeding has to be elaborated with the responsible persons and an eventual salary system should be discussed. Buckets for collection of organic wastes should be provided and feeding organized as convenient as possible.

In terms of the slurry use, the analyses have shown that restricted irrigation is possible. Instead of promoting the use of slurry on vegetables, the irrigation of banana trees seems to be promising, especially because the direct contact between effluent and fruit can be ruled out. Banana trees are widespread in Nepal, its fruit is popular among Nepalese and the trees show a high water demand and high nutritional requirements.

Although the technical evaluation of all digesters showed very positive results, emphasis has to be laid on the maintenance of the systems. In none of the three prisons, a clear maintenance strategy was observed. This implies that no preventive tasks are ensured to guarantee smooth operation of the facilities. In case of problems, the chaukidar (leader of detainees) trouble-shoots (given his privilege to leave the internal prison perimeter). However, wardens, security staff and chaukidar have to be more aware of the necessity of regular maintenance, which should include:

- Removal of condense water (bi-monthly)
- Checking for leakages in the kitchen (bi-monthly)
- Regular cleaning of the stove (weekly) and
- Checking for leakage of the gas pipes with a special focus on joints and elbows (monthly or at least every second month).

The initially formed user committee in jail 1 did not prove to be effective due to a lack of capacity or more likely a lack of motivation. After discussions with the chaukidar, wardens and detainees at jail 1 the following was suggested: A calendar should be prepared including a list of maintenance duties. The chaukidar shall have the overall responsibility and the authority to assign the maintenance tasks to reliable inmates which need to accomplish the tasks at the notified date of the month. After having executed their assigned work and informed the chaukidar, he will tick off the task on the calendar. This way, the responsibilities are clearly allocated and the work can easily be

controlled. This duty calendar seems to be an interesting approach, yet its application needs to be supervised in the first phase after introduction.

In addition to this self-maintenance, at least once per year maintenance by an external party should be conducted either by the biogas construction company or an independent expert. Monitoring of the facilities should include daily measurement of gas production and pressure tests to check for leakages of the dome and the piping between digester and kitchen.

CONCLUSIONS

This evaluation concludes that biogas plants are an appropriate solution for a combined treatment of blackwater and kitchen waste in prisons as well as in similar institutional frameworks in developing countries. However, the widespread verdict “a technology is only as good as its operation and maintenance” also applies in the biogas/prison context. The best promotion of a technology is its proper functioning and the respective acceptance by its users. For biogas digesters at institutions, issues of strong ownership and responsibilities for maintenance work are crucial points which need special attention. If not properly operated and maintained, the adverse effects such as methane emissions (greenhouse gas) or health risks of leaking gas pipes in the kitchen can clearly exceed the benefits.

Following the positive experience in Nepal, ICRC will pursue this approach in prisons in other countries and support the promotion of biogas plants for institutions (prisons, schools, hospitals) in order to improve the sanitary conditions and provide renewable and clean cooking energy.

ACKNOWLEDGEMENTS

The authors would like to thank all detainees and prison staff for their willingness to share their experiences with frankness, openness and good humor which made this study possible and an unforgettably pleasant experience. This project was made possible by the logistical support of Gisella McGuinness (ICRC WatHab Nepal) and benefited of fruitful discussions and support by colleagues in Kathmandu: Shishu Koirala , Indra Shrestha, Usha Khadka, Narayan Karki (all ICRC WatHab Nepal), Rashmi Shrestha (Kathmandu University), and Charushree Nakarmi (BSP-N), and then also Christopher Kellner in Zambia, Urs Baier (Zürich University of Applied Sciences), Hanspeter Marti (Swiss Tropical Institute), and Simon Galenda (Eawag laboratory). The authors would also like to acknowledge the financial support of ICRC, Swiss Agency for Development and Cooperation (SDC), the Swiss Federal Institute of Aquatic Science and Technology (Eawag) and the NCCR North-South research programme.

REFERENCES

- Biogas Sector Partnership-Nepal BSP-N (2008): Assessment, construction and monitoring of biogas plants in Kaski, Chitwan and Kanchanpur District Jails. Final completion report, January 2008. Unpublished.
- Karki, A., Shrestha, J.N., Bajgain, S. (2005): Biogas - a renewable source of energy in Nepal. Theory and development. BSP-N, July 2005
- Lohri, C. (2009) Evaluation of Biogas Sanitation Systems in Nepalese Prisons. Eawag. Switzerland. Unpublished report.
- World Health Organization WHO (2006): WHO guidelines for the safe use of wastewater, excreta and greywater; Volume 4: Excreta and greywater use in agriculture