

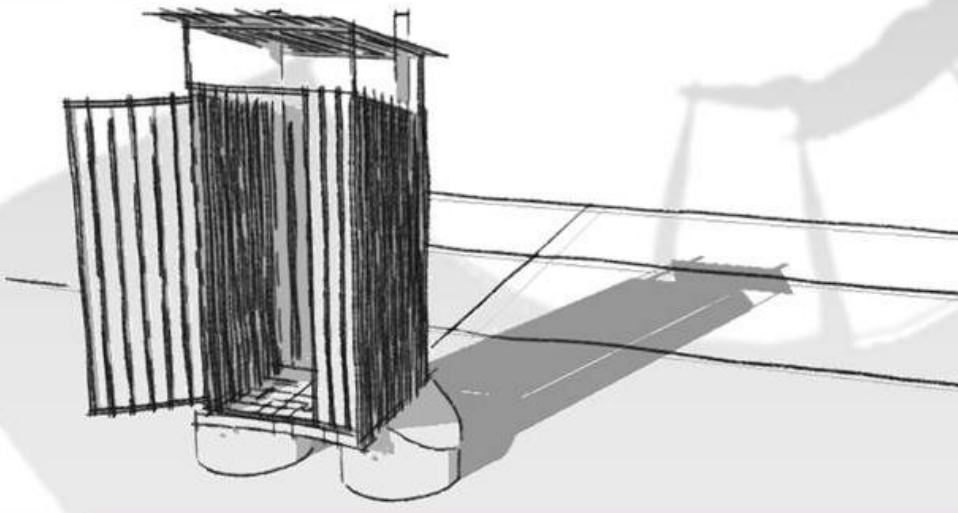

# EASY shower latrine

Technical handbook



## LATRINE CONSTRUCTION

Summary	1
Urine Diversion Dry Bathroom	2
Pour flush latrine	3
Pour flush micro septic tank	4
Initial investment, location, human resources	5
Concrete rings	6
Box	7
Cover	8
Slab dimensions	9
Slab mold	11
Ring mold	14
Structure and accessories	16
Construction process	17
Concrete Reinforcement	18
Box mold	19
Drip irrigation specifications	21
Construction site	22

## SHELTER CONSTRUCTION

Shelter	23
Production methods	25
Initial investment	27
Lid and ventilation pipe	28
Patterns	29
Corrugated iron cutting models	34
Handout	36

This guidebook is aimed at sanitation practitioners who are interested in implementing a sanitation marketing program using eco-sanitation design, with no subsidies for mason or clients, based on technical and marketing training. We hope you'll have a pleasant read and that you'll find all the information you need.

## Summary of the idea

We propose a new and complete model for a rural sanitation system. The main design is for a combined shower and dry latrine which contains a number of innovative features from the production process to the adaptation of the product for a sanitation marketing approach.

This is possibly the first time that a toilet, replicable via an industrial process has combined all these elements at such a low cost, giving choice to the people between pour flush or UDDT for the same price, making possible its introduction to the market without subsidies. In order to share the solutions to lowering the price of this toilet, we have developed this technical handbook where you'll find all the information you need to start production.

The main aim of presenting three designs is to allow you to adapt your production to people's technological demands and willingness to use UDDT. These three models are made out of the same molds and sold for the same price, which result in a cheaper investment for the mason.

## Keys strategies of the design

- The design includes a shower as well as a toilet, so that there is increased motivation for maintenance.
- The water and urine run-off is connected to a drip irrigation system – the best practice for water management.
- Two compartments for dry feces collection are included. Once one compartment is full (predicted to be after six months for a family of five) users will switch compartments and let the previous pit contents change into valuable compost.
- Two alternate designs for a pit latrine are also included (easy latrine/easy septic tank), at the same price, for people not willing to use UDDT. The same molds and same shelter are used for both the pit latrine and the UDDT products proposed, making investment cheaper for the mason.

## Links

Easy shower video presentation ; <http://www.youtube.com/watch?v=-3Ox27fdF4A>  
Easy latrine video presentation : <http://www.youtube.com/watch?v=zloOePIhQzc>

More information/contact : [benclouet8@hotmail.com](mailto:benclouet8@hotmail.com)  
IDE website : <http://www.ideorg.org>  
GRET website : <http://www.gret.org>

## Urine Diversion Dry Bathroom (toilet + shower) with drip irrigation system

This concept has been developed by Benjamin Clouet in Cambodia as part of a sanitation marketing program. Using the same rings, same molds and at the same price as the two flush sanitation products described below, this UDDT connected with drip irrigation system has been called the "easy shower" here in Cambodia. The two pits will be used alternatively (once one gets full, the other is used allowing the dry feces to convert into valuable compost over six months) and all liquids (shower, female urinal, anal cleaning) go into the collection pipe at the center and straight to the irrigation system. Ashes or wood chips will be introduced in the pits after each use.

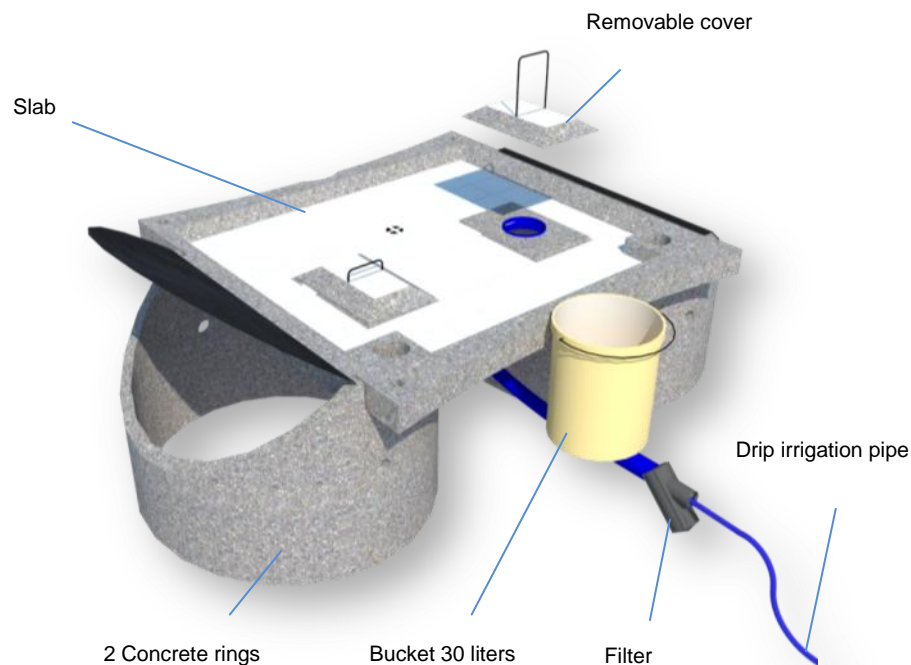

- Quantity of concrete : 150 liters = 300 kg
- Effective capacity volume : 250 liters
- Labor time for construction of elements : 1 day worker
- Average material total price : 25 US\$ = 100,000 Riels

## Pour flush latrine

Developed by IDE-Cambodia, the "easy latrine" was inspired by the double pit latrine design originally developed in India by Sulabh International. However, the main adjustments we have made to this technology are to the price and the production methods. The construction methods are therefore at the center of the design, and we'll try to explain them clearly.

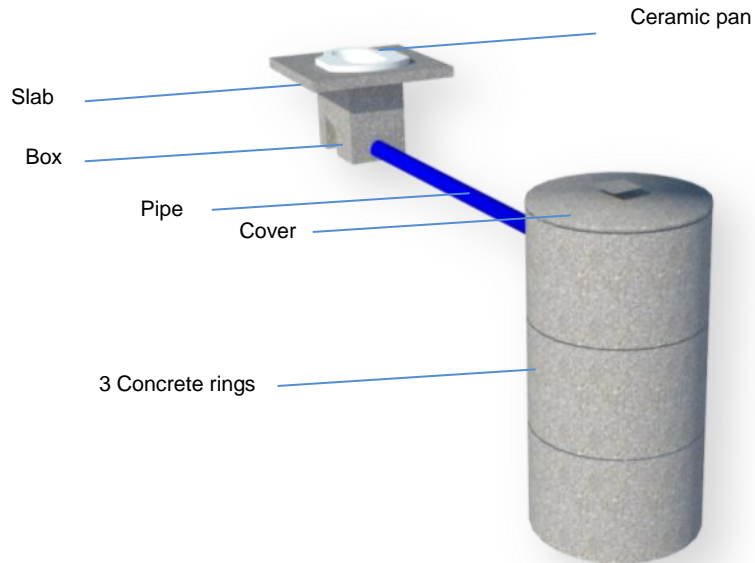

The elements will be described in the following chapters

- Quantity of concrete : 190 liters = 400 kg
- Effective capacity volume : 650 liters
- Labor time for construction of elements : 1 day worker
- Average material total price : 19 US\$ = 80,000 Riels

## Pour flush micro septic tank

This concept was developed by GRET in areas where the bed rock is very shallow, making it impossible to dig more than 50 cm in depth. An optional third ring placed after the second pit and before the infiltration pipe will improve the treatment capacity of the latrine.

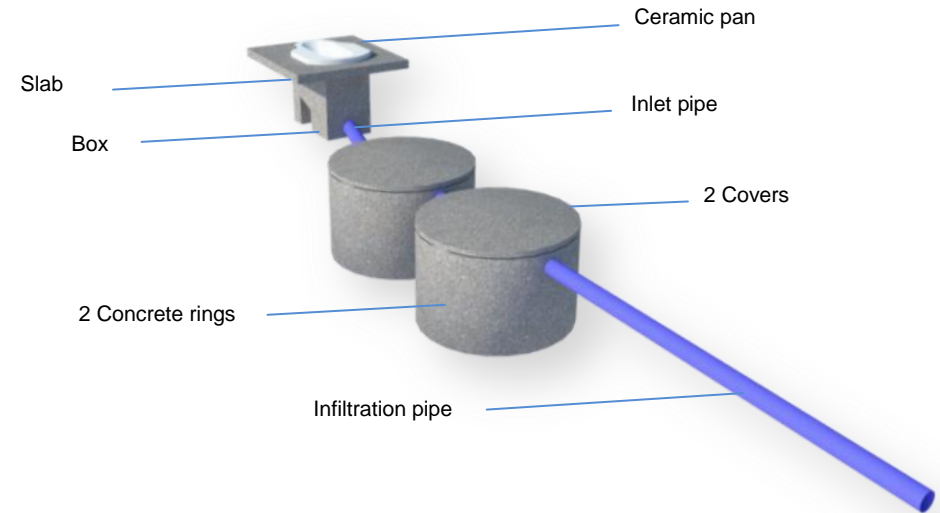

- Quantity of concrete : 175 liters = 380 kg
- Effective capacity volume : 450 liters
- Labor time for construction of elements : 1 day worker
- Average material total price : 21 US\$ = 88,000 Riels



A second pit should be purchased by the user. When full, the first pit should be filled with soil. After an average of 10 months the night soil becomes valuable compost. The second pit is usually sold for 10 US\$. You can reuse the same pipe for both pits by changing the angle.

## Core toilets Initial investment, Location and Human Resources

The following material and investment allow a **production of 3 complete latrine or shower/day**.

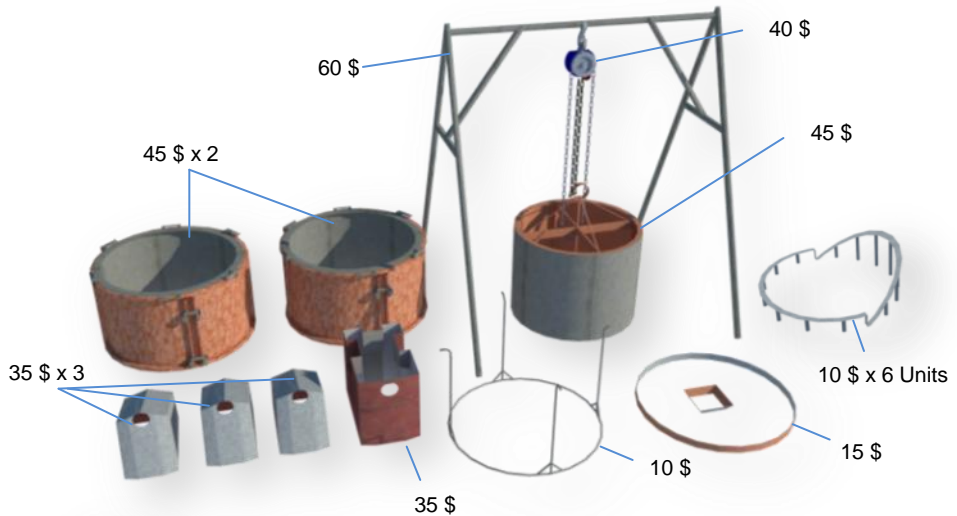

**TOTAL MOLD : 460 US\$**

Investing an additional \$45 for a third outside mold increases production capacity from 10 rings/day to 15 rings/day.

To ensure product quality and optimal concrete strength the thinner rings of this technology require the concrete to cure (i.e.: not be moved) for 10 days before it can be transported.

**INITIAL STOCK : 350 US\$**

Working team: **3 Laborers**



Land requirement: **100 m<sup>2</sup> Minimum**

Water access: **350 liters/day**

Cement stock: Covered area for cement required

Transport mean: Able to transport minimum 2 complete latrines on local roads (800kg and 3 m<sup>2</sup>)

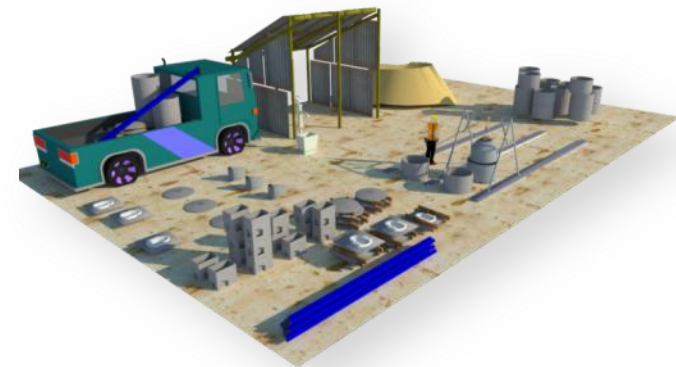





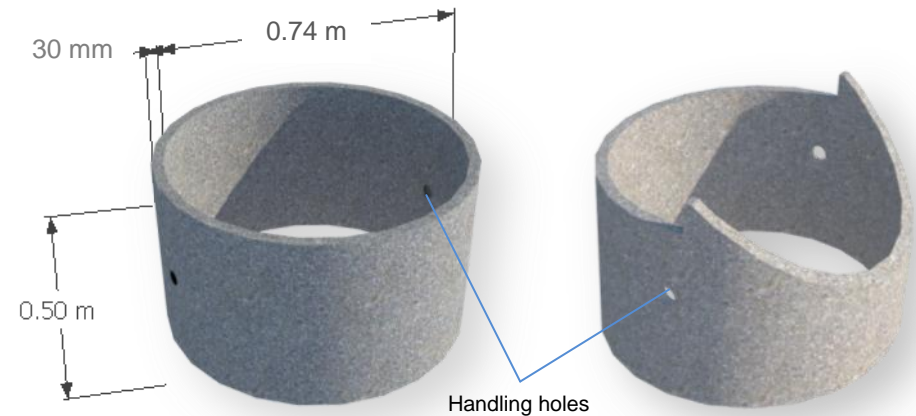

## Concrete ring

The concrete ring is a fairly simple element made from different methods and molds according to the country or region. Here we present an efficient, upgradable and cost-cutting method to make rings that are strong enough to be transported several kilometers on bumpy roads without cracking or breaking. On the left is the ring used for pour flush systems, on the right is the ring used for the easy shower.



Two handling holes are needed to transport the rings, a bar through the handling holes will make it easy to move. The total weight is 80 kg, and inside volume is 250 liters.

Element	Kg/m <sup>3</sup>	Weight kg	Volume l	Price (riel)	Price (\$)
Sand 	1600	62	39	1,500-1,700	0.35-0.4
Water 	120	4.5	3		
Cement 	400	12.5	4	5,000-7,000	1.2-1.65
Rice Husk Ashes 	20	0.61	2		
Reinforcement 	5	0.06		500-1,000	0.1-0.23
		80 kg	39 l	<b>7,000-9,700</b>	<b>1.65-2.3</b>

 Adding 5% of the cement weight as rice husk ashes increases the concrete strength significantly **but decreases** it if you put a higher ratio.

## Box

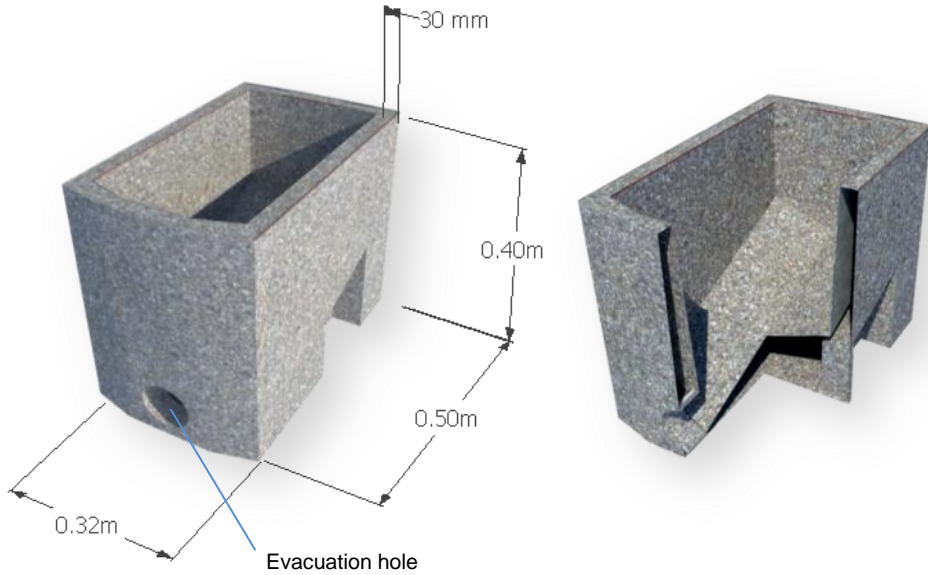

The box is a key element in both latrine designs and requires lots of care especially when the molds are made. The diameter of the evacuation hole is sufficient at 80 mm, but could be bigger.

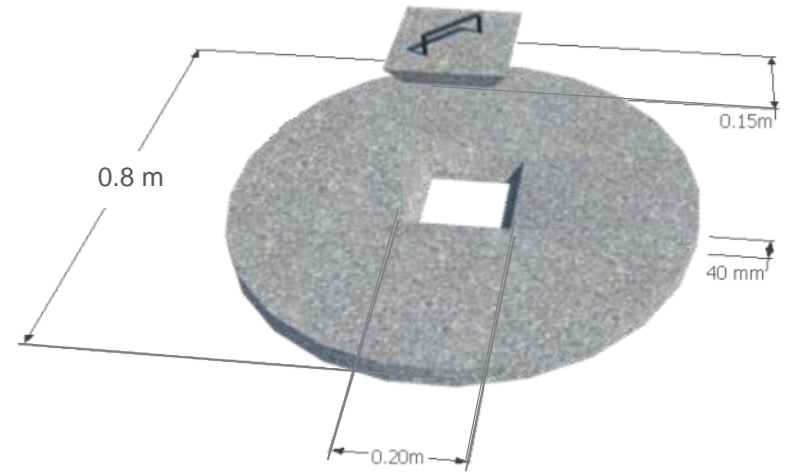

## Cover

The hole's cover has an "upside down pyramid" shape, but can be adapted to what is commonly found in the area. It is important to make sure that the sludge removal tool (pipe, pump, gulper, etc) can fit through the hole.



Element	Kg/m <sup>3</sup>	Weight kg	Volume l	Price (riel)	Price (\$)
Sand 	1600	38	23	900-1100	0.2-0.25
Water 	120	2.7	2	20	
Cement 	400	10	3	4000-4200	0.9-1
Rice Husk Ashes 	20	0.3	2	20	
Reinforcement 	1	0.02		50	
		50 kg	25 l	<b>7,000-9,700</b>	<b>1.1-1.25</b>

Element	Kg/m <sup>3</sup>	Weight kg	Volume l	Price (riel)	Price (\$)
Sand 	1600	36	50	900-1100	0.2-0.25
Water 	120	2.6	2	20	
Cement 	400	9	3.2	4000-4200	0.9-1
Rice Husk Ashes 	20	0.3	0.7	20	
Reinforcement 	70	1.4		4000-5000	1-1.2
		58 kg	25 l	<b>8,950-10,350</b>	<b>2.1-2.45</b>

## Slab and ceramic pan for pour flush systems



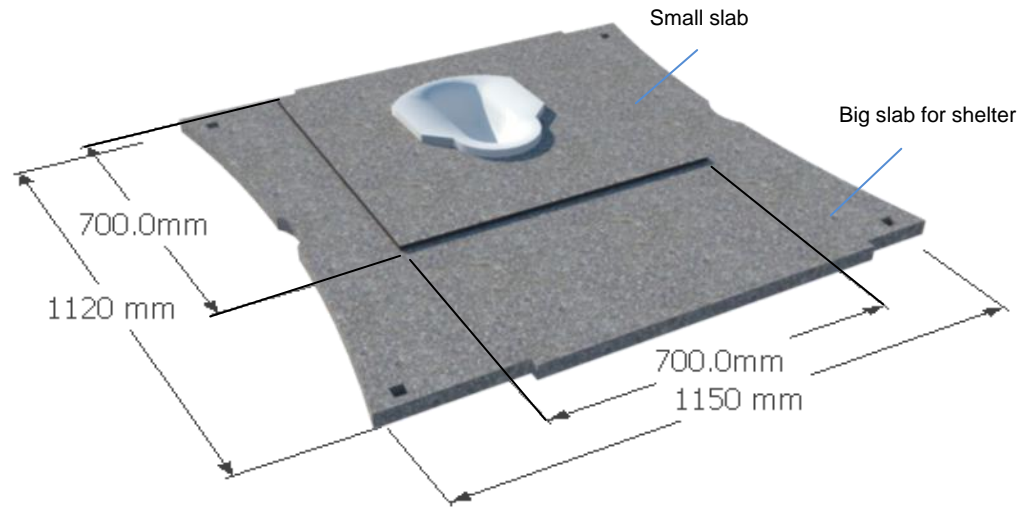

Different slab dimensions can be used with or without the shelter. The holes in the slab make it very easy to build (see page 13). The left columns (white) of the quantity chart refer to the small slab (0.7 x 0.7 m), the right columns (grey) refer to the big one (same size as easy shower slab presented further on).



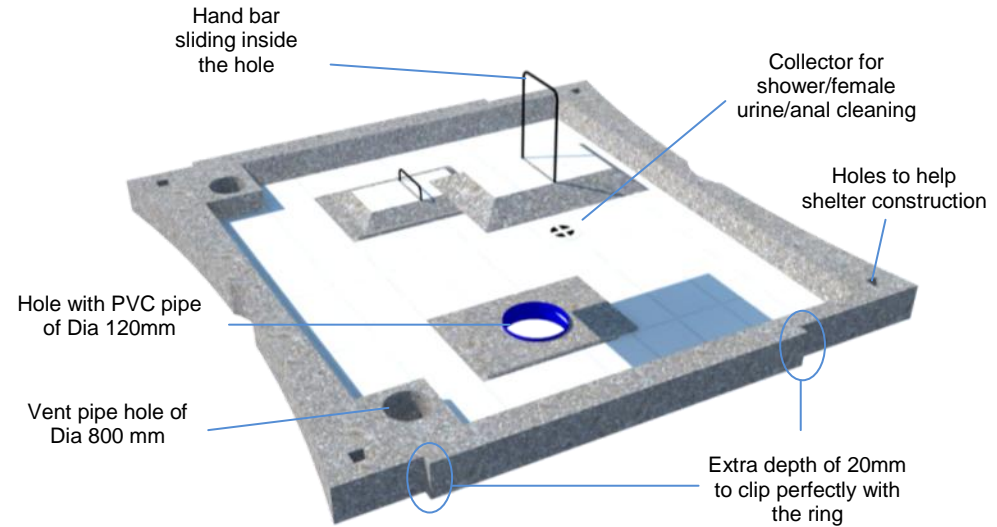



## Slab for easy shower

The slab of easy shower has a lot of small, specific details which make it easier to use and maintain. The design has two goals, firstly to collect all water through the central collector, and secondly to avoid any water in the two dry pits and consequently avoid water reaching the feces hole.



Element	Kg/m <sup>3</sup>	Weight kg		Volume l		Price (riel)		Price (\$)	
Sand 	1600	32	64	50	100	1000	2000	0.2-0.25	0.4-0.5
Water 	120	2.6	5	2	4	20	40		
Cement 	400	8	16	3	6	3900	7800	0.9-1	1.8-2
Rice Husk Ashes 	20	0.3	0.6	0.7	1.4	20	40		
Reinforcement 	70	1.4	3			4500	9000	1-1.2	2-2.4
		47 kg	95 kg	19 l	38 l	9,000	18,200	2.1-2.45	4.2-4.9

Element	Kg/m <sup>3</sup>	Weight kg	Volume l	Price (\$)	
Sand 	1600	64	100	2000	0.4-0.5
Water 	120	5	4	40	
Cement 	400	16	6	7800	1.8-2
Rice Husk Ashes 	20	0.6	1.4	40	
Reinforcement 	70	3		9000	2-2.4
		95 kg	38 l	18,200	4.2-4.9

With Tiles = 10\$ extra

# Slab Molds

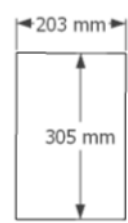
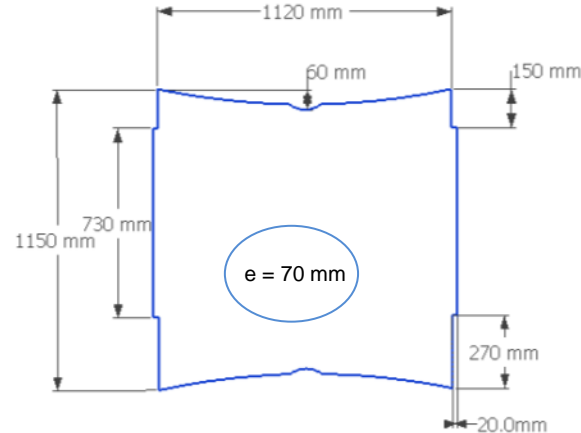
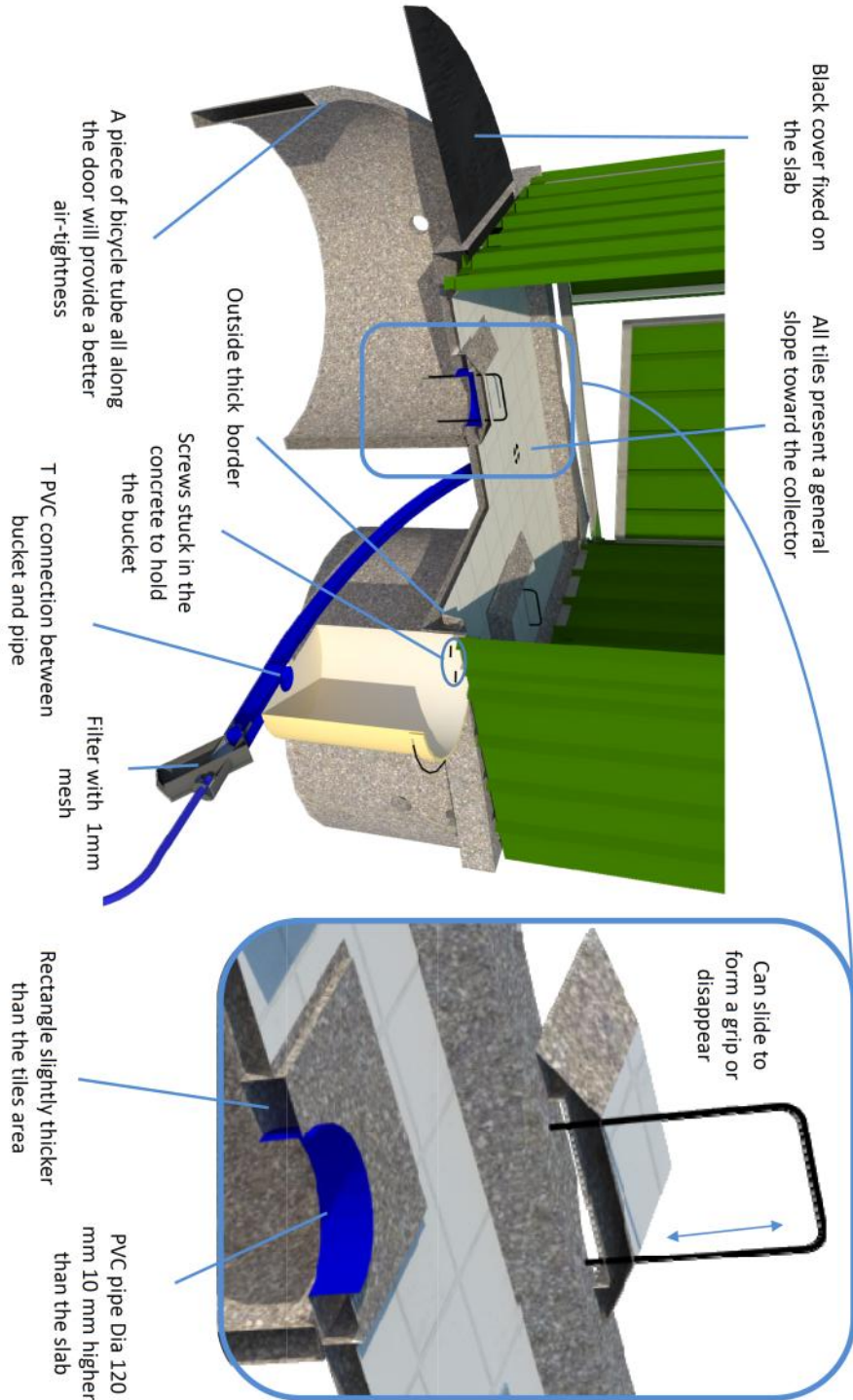

The inside slab molds are used only for the easy shower slab, allows us to make the center part of the slab in ferro-cement (very thin concrete with metal mesh instead of re-bars) of only 20mm thickness when the outside part of the mold is 70mm. The small one on the left is used to elevate concrete around the drop holes.

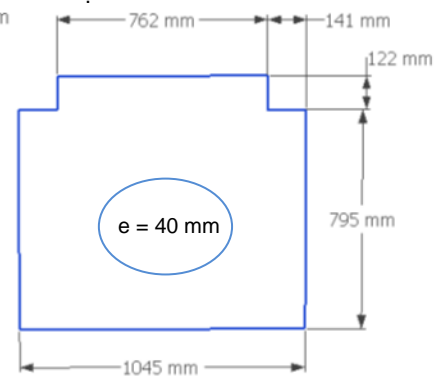

The outside mold of the big slab is symmetrical, and is 70 mm high. For the easy shower, with the help of the inside slab molds shown below, this allows a higher thickness on the outside of the slab and around the drop holes to prevent water leaking out. The round shape saves concrete, and gives a nicer look to the slab. The small inner round shape allows the bucket to be firmly stuck to the concrete. The corners allow the slab to clip nicely in the rings.

The pre-fabricated shelter is designed to be installed with the big slab, as illustrated on page 19. The shelter supports are inserted into the holes in the slab. The big slab needs to be produced with four precisely located holes so the holes line up with the shelter supports.

Use a metal frame that is inserted into the wet cement of the Big Slab to create these holes and remove it when the concrete is strong enough - two hours should be enough. Create the metal frame following the dimensions.

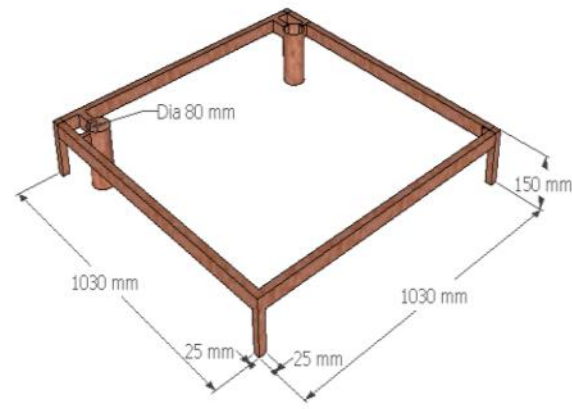

Once the drop hole part is made thicker with the small mold presented earlier, another mold has to be done to make the hole cover in concrete. This is a pyramid of 30mm high with six tiles on the base and two tiles on the top.

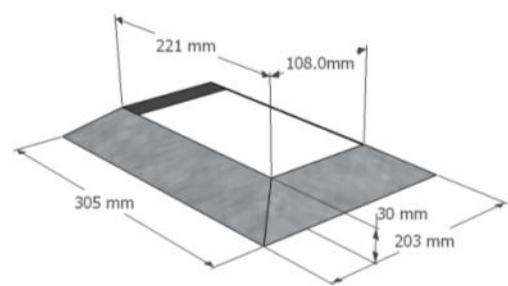

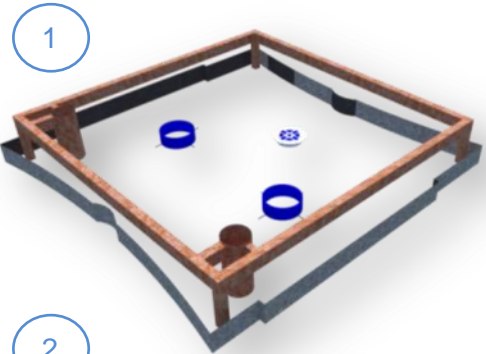

1

The construction of the slab starts with placing accurately the PVC pipes (Dia 120mm, 35mm long), the water collector and the hole mold. The PVC pipe is nailed so it won't move after concrete is poured.

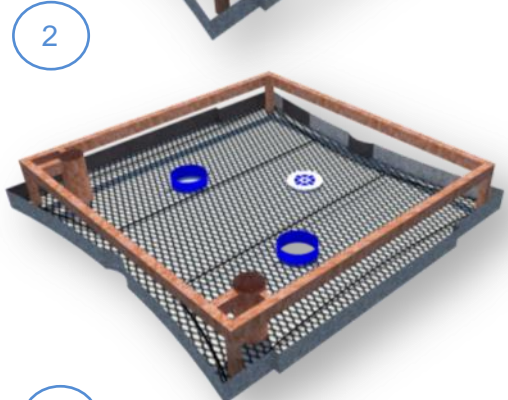

2

(1) First concrete is poured on only 10mm, then is added a chicken mesh all over (ferro-cement pinciple) and steel bars Dia 4 mm on the outside (2). Another 10mm concrete is added on the top.

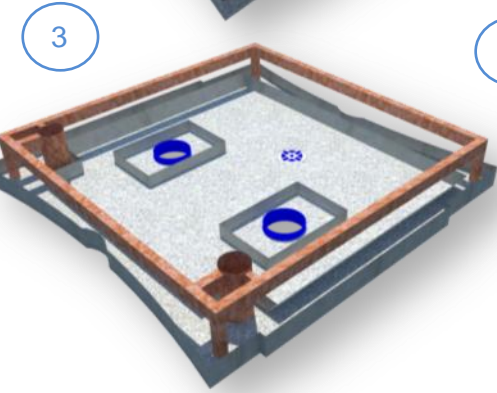

3

(3) The three other molds are placed well centered and concrete is poured around the PVC pipe and on the outside. Screws can be put in the concrete so they will allow us to fix the bucket and pit lid to the slab after.

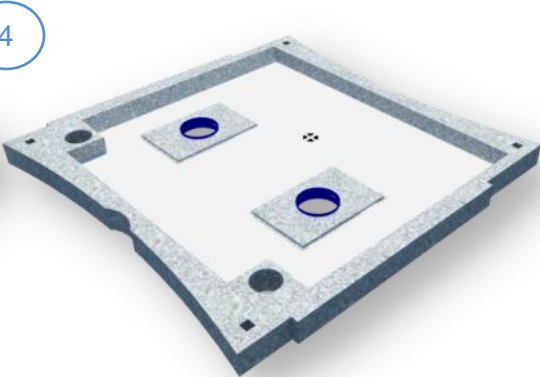

4

(4) The last part consists in making a general slope on the tiles toward the center collector. You need to remove the hole mold after 2 hours, so it doesn't get stuck in the concrete. Some screws can be added inside the concrete to receive the pits cover and allow to fix nicely the hinges.

## Ring Molds

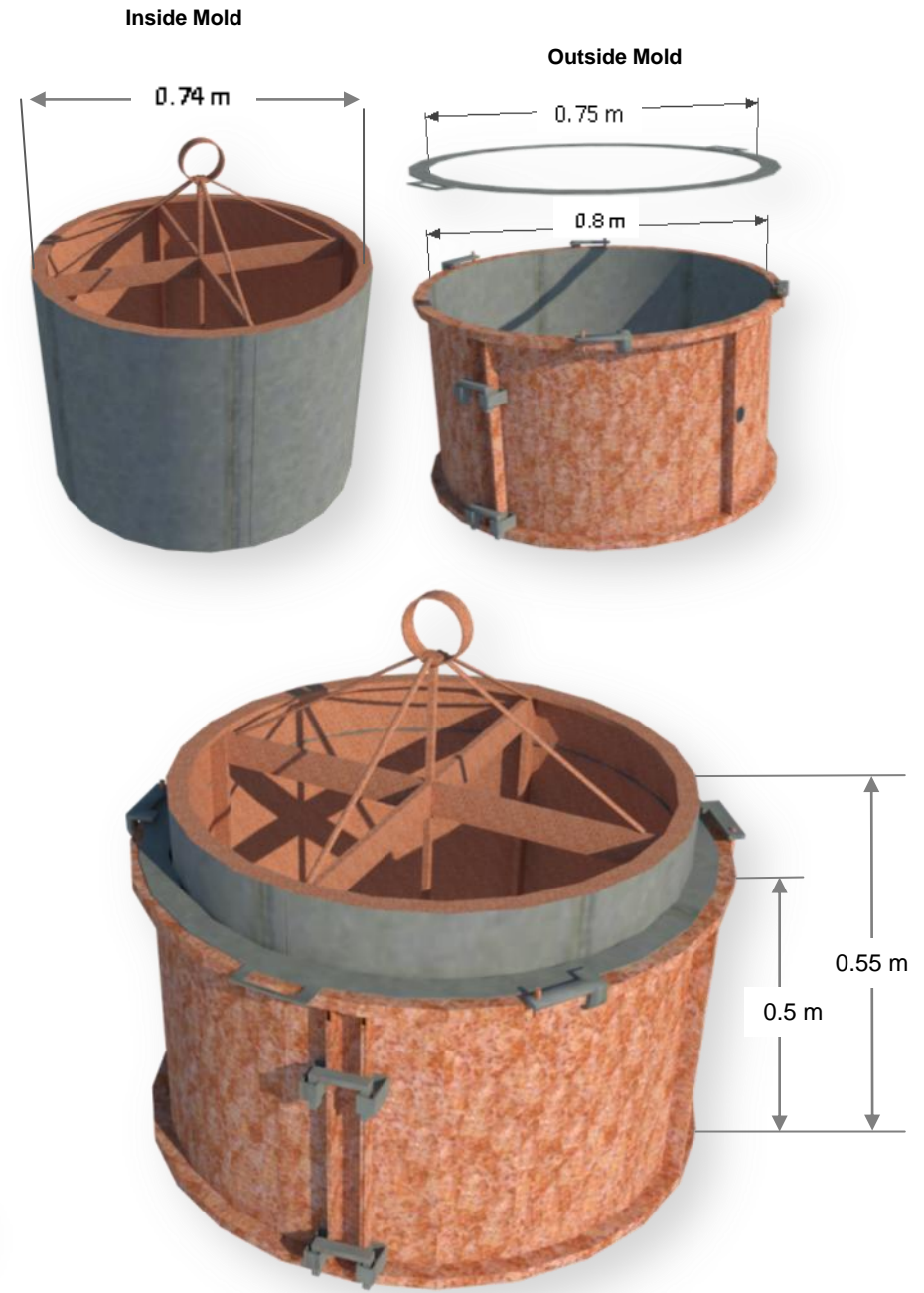

To make the two concrete hole covers, you first need to put the pyramid mold and the tiles in upside down, then pour in the concrete keeping a spherical hole of 1cm so the PVC pipe will slide in. Make two small holes when the concrete is getting drier for the handle.

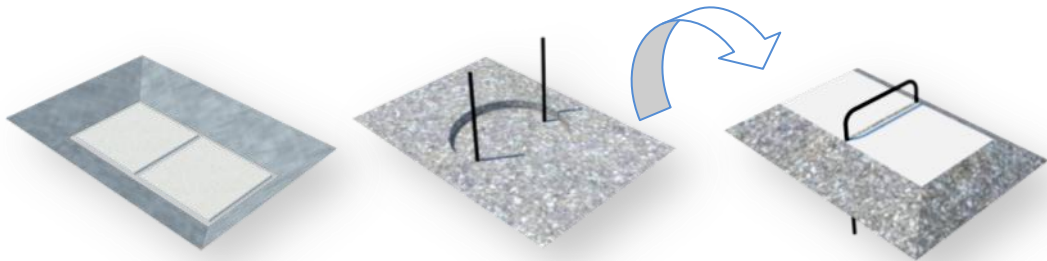

13

14



Ring for holding the lifting hook (crane)

Placing the hook higher enable the mold to stay vertical when lifting up

2 mm metal sheet, 2.51 x 0.6 m

Mold lid

Inside mold reinforcement will prevent unwanted deformations

OPEN

CLOSE

Clip to block the lid and therefore the concrete when lifting

## Structure & accessories

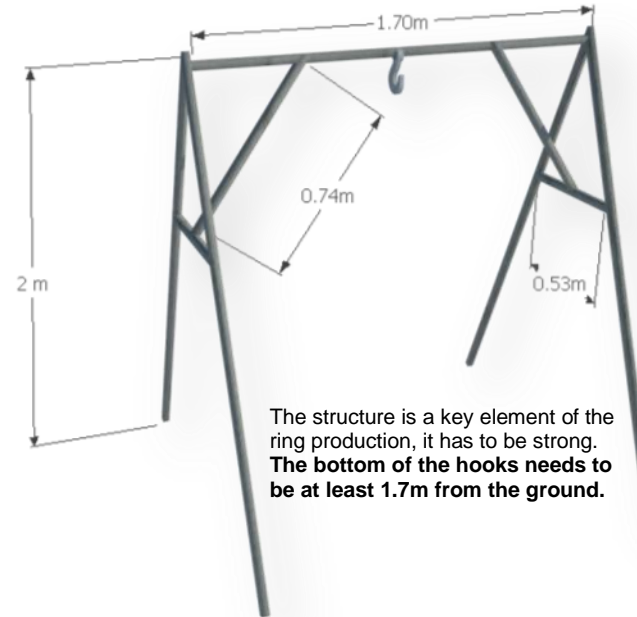

The structure is a key element of the ring production, it has to be strong. **The bottom of the hooks needs to be at least 1.7m from the ground.**



The crane has to be able to lift **2 tons.**

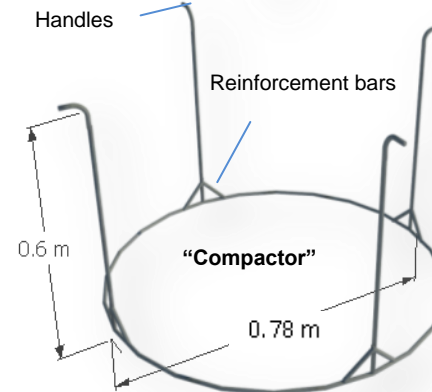

**"Cut ring mold"**  
For easy shower

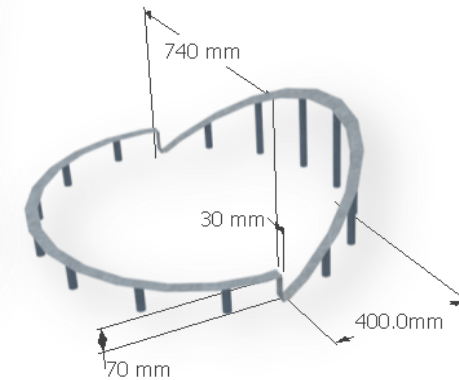

The concrete is very dry and needs to be compacted as the mold is being filled. The "compactor" tool needs handles to protect the laborer's hands and reinforcement bars are needed to make the tool more durable.

The cut ring mold is placed at the bottom of the ring mold and will give the desirable shape to the ring. If dimensions are followed carefully, the slab will simply clip into the two cut rings

## Construction Process

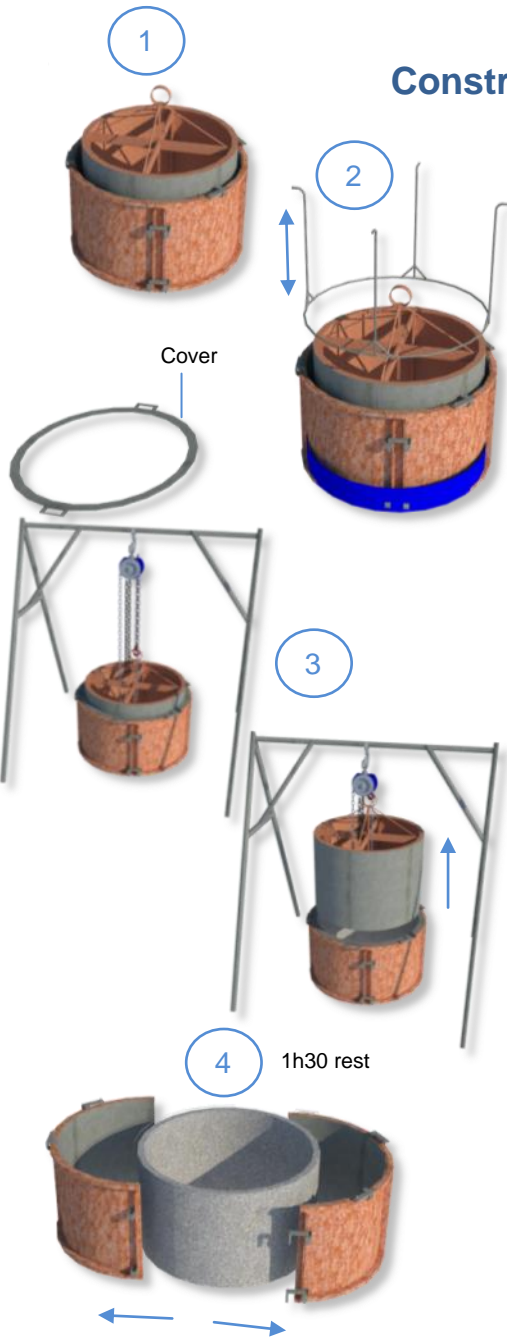

**STEP 1 (1)** Put oil, diesel or any other grease on the molds to prevent sticking to the metal molds.

The concrete has to be very dry so it will keep its shape when the inside mold is removed. After a few tests the right concrete consistency will be found.

**STEP 2** Gently and equally pour the concrete inside the molds. After a third of the mold (marked in blue on the picture) is filled, start using the "compactor" (2) which will compact the concrete and remove any air bubbles stuck inside the concrete.

Compact the concrete for 1-2 minutes then place the first 2mm reinforcement wire inside the mold taking care to place the reinforcement wire 15cm apart. When the mold is full, place the mold lid on top and close the clips.

Once the mold is full of concrete and well compacted, put the cover and close the clips all around the outside mold. Once it's done, place the crane (3).

**STEP 3** Place the crane over the closed mold. To lift the mold, one laborer has to stand on the top of the outside mold to make it easier to remove the inside mold. Lifting must be done smoothly and without stopping to avoid poor quality rings. Step 3 is completed when the inside mold is removed.

**STEP 4** The outside mold and the concrete need to be left untouched for 1hr30min - 2 hours, depending on the quality of the sand (4). After this time is completed, open and remove the outside mold. The outside mold can now be reused to make another ring.

This method of production is very attractive because money is saved by needing only one inside mold and greater production volume is achieved with the accelerated curing process (1hr30min compared to 3 hours with traditional practices) This production technique is easy and fast to learn and takes only a few practice tries to perfect the technique.



The rings have to cure for **10 days** before transportation, in order to let the concrete reach half its final strength.

## Concrete Reinforcement for other elements

### Basic rules of reinforcement bars

The steel bars have to be attached to one another with wire – The reinforcement steel bars should always be placed in the middle of the concrete, because of the thinness of the concrete components this is of extreme importance – High adherence steel bars should be used, but smooth bars can be used – The steel bars need to be inside the concrete and not at all visible on the outside - DO NOT use bamboo reinforcement for these elements this will produce a low quality product that risks braking and harming users.

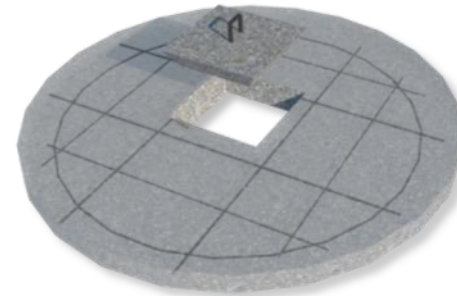

The cover metal reinforcement are usually **4 mm** diameter but should be bigger if we expect cars or heavy loads on this cover through the time. Almost **7 m long are required for the cover**. It is extremely important to place the steel bars in the middle of the concrete.

The center hold cover doesn't need reinforcement but a handle bar for lifting.

The steel reinforcement for the slab needs to be at least **4mm diameter**. **4.2 m long are required**. Placement of the steel reinforcement is more important than the diameter of the steel. The steel bars need to be placed underneath the ceramic pan at the edges to support it - placing the steel bars too far towards the middle of the ceramic pan will make it difficult to form a seal between the ceramic pan and catchment box when the latrine is assembled.

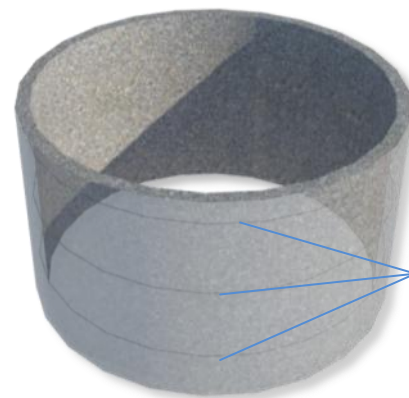
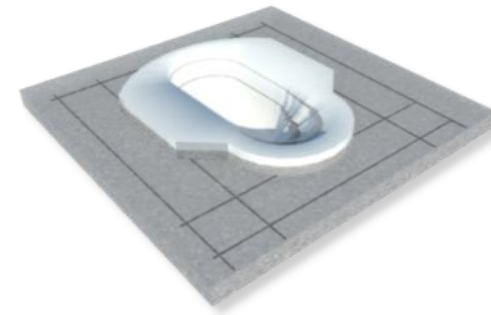

Reinforcement for the rings is very thin stainless steel wire, 2mm diameter. Three rings of the wire needs to be placed equal distance apart while avoiding covering the handling holes in the middle.

Reinforcement bars

# Pour flush systems Box mold

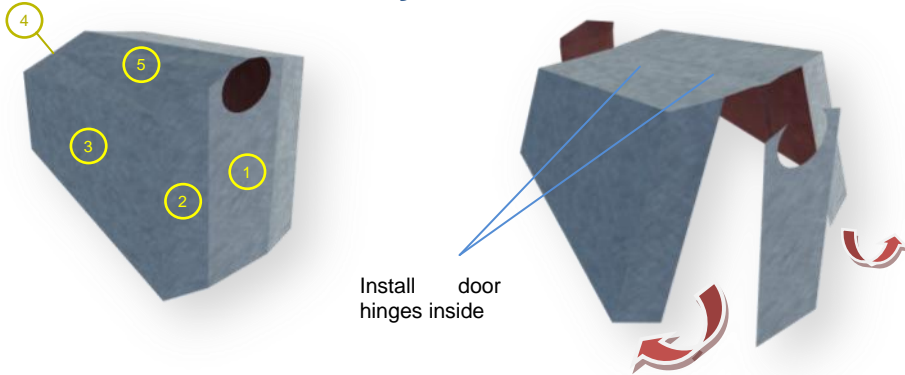

 The inside box mold has a pyramid shape, giving it a smooth angle shape which makes mold removal easy. This point is very important if you don't want to break the box when you're removing it and to minimize breakage during removal.

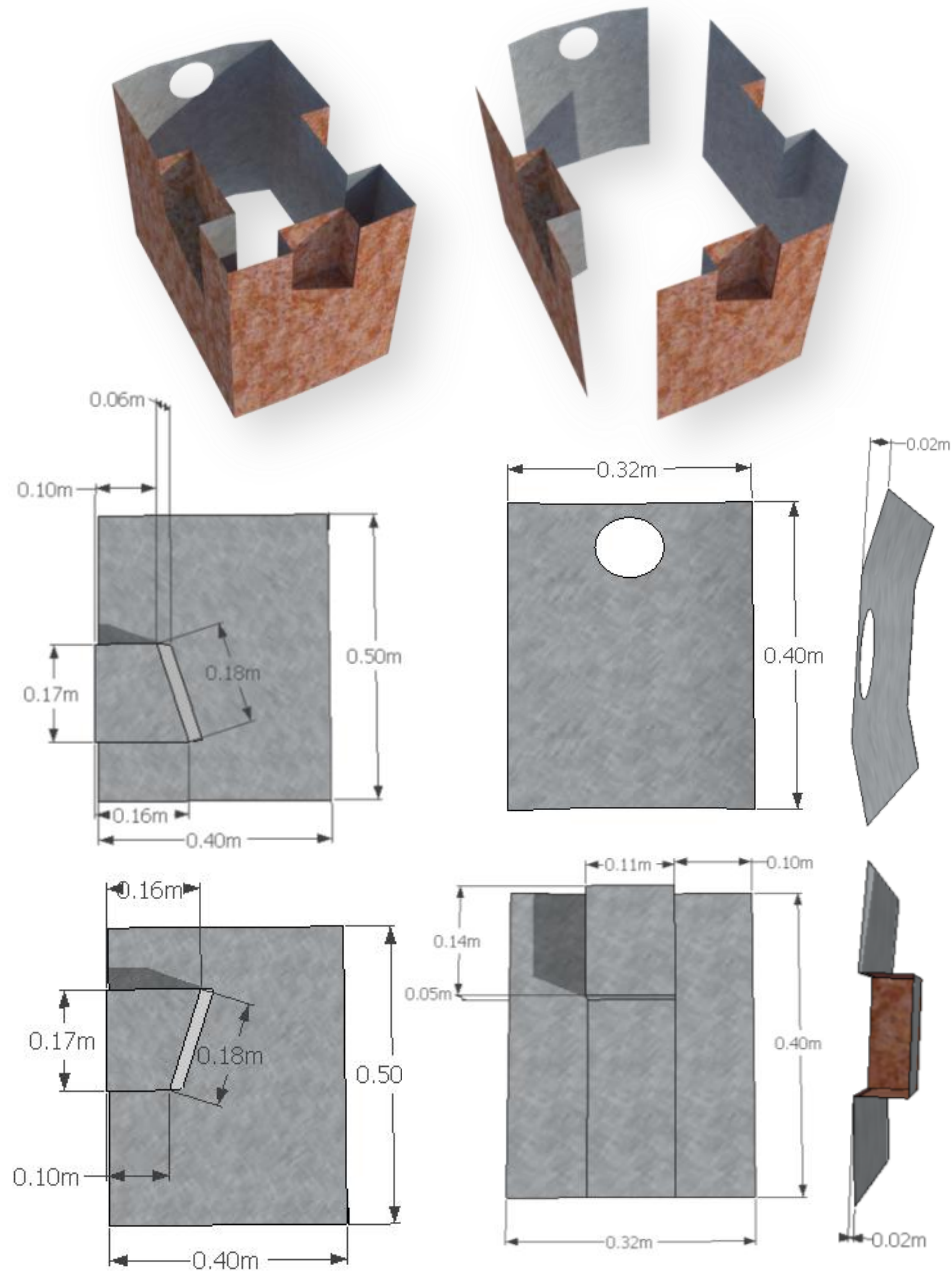
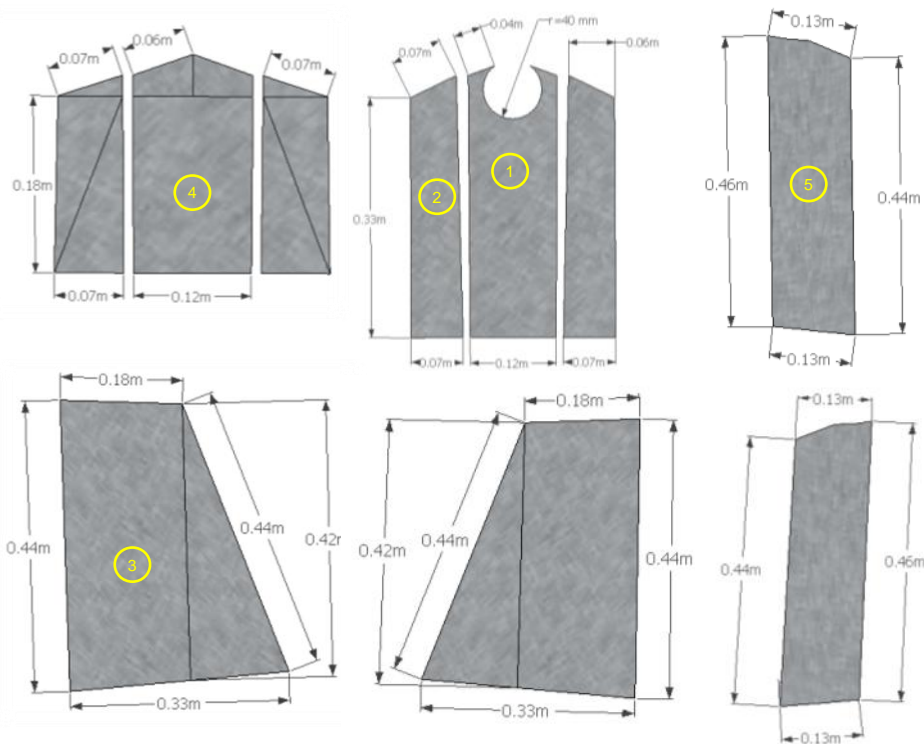

## Drip irrigation specifications for 80 m<sup>2</sup> garden

The filter ensures that clean water enters the system.



**Take-Off Tee:** Connects the lateral pipes to the sub-main pipe. It is fixed in the wall of sub-main pipe with the help of a rubberwasher called a grommet.

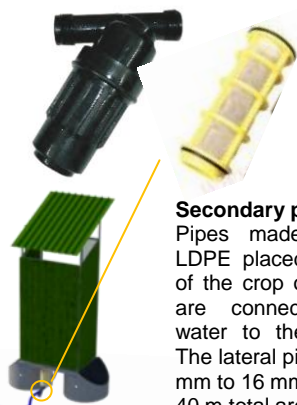

**Secondary pipe:** Pipes made of LLDPE or LDPE placed along the rows of the crop on which emitters are connected to provide water to the plants directly. The lateral pipe size is from 12 mm to 16 mm. 40 m total are required

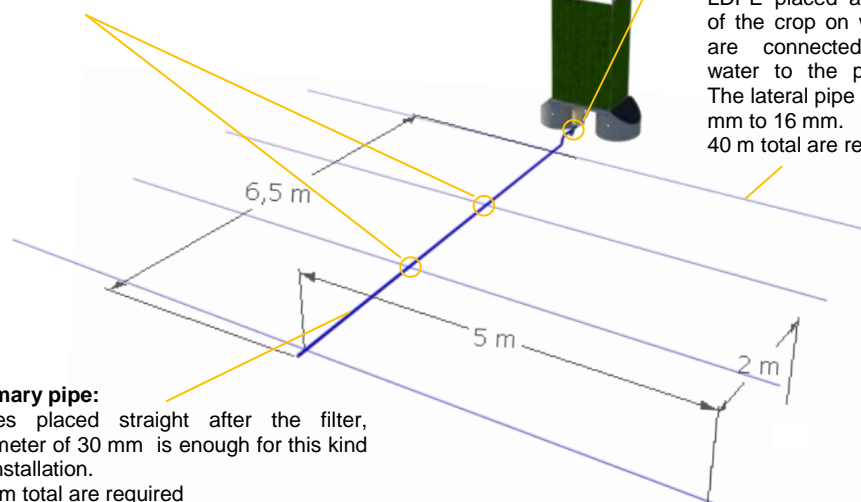

**Primary pipe:** Pipes placed straight after the filter, diameter of 30 mm is enough for this kind of installation. 6.5 m total are required

**Micro-tube/emitter:** Straight or curled LLDPE tube with an inner diameter ranging from 1 to 1.2 mm. Flow from the micro-tube increases with pressure and decreases with length. Inserting the micro-tubing **every 30 cm** on each side of the secondary pipe, ensure better flow uniformity.



## Construction plant

The layout of the construction site is important to reduce the distance from one task to another and to make stock easy to access by the delivery truck for transportation. **The minimum construction site size for production capacity of 3 latrines/days is approximately 100 m<sup>2</sup>.**

The construction site needs to have access to sufficient water needed for production. Each latrine requires approximately 100 liters of water plus water for drinking and cleaning the tools and ceramic pans. **Access to at least 350 liters of water/day is needed for production capacity of three latrines / day.**

The construction process needs to be close to each other, going in order, starting with inputs (sand, cement, water) to the finished product.

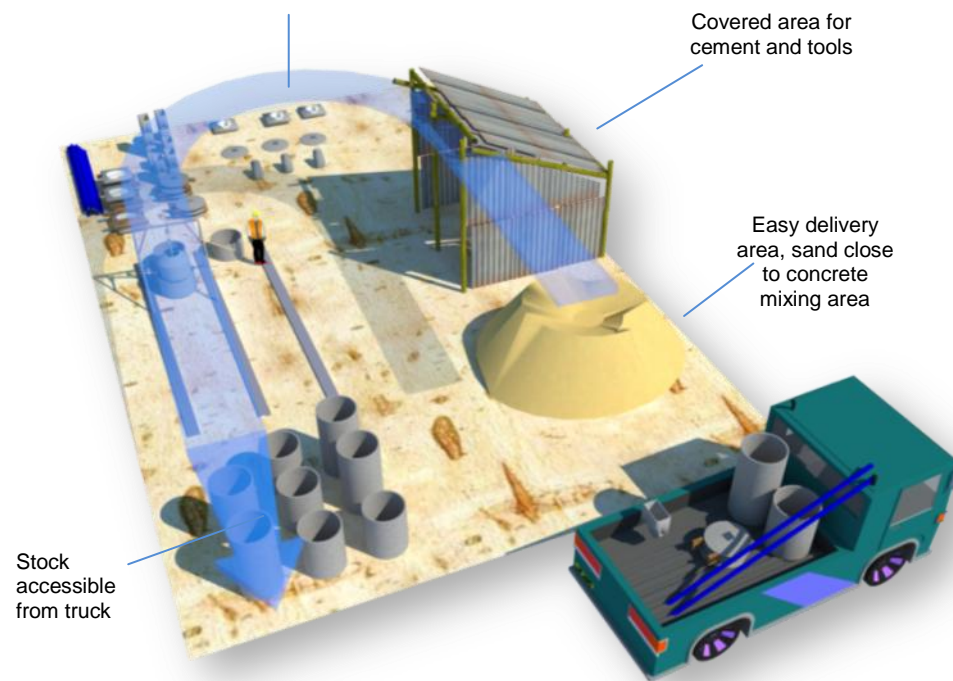

Stock accessible from truck

Covered area for cement and tools

Easy delivery area, sand close to concrete mixing area

Problems	Cause	Troubleshooting
Micro tube/ emitter not delivering water.	Clogging due to impurities in water or air bubble in micro-tube	1. Take out micro-tube from lateral pipe and shake it or blow it so to remove dirt or trapped air. If button type emitter / micro sprinkler, open and clean with a needle. Re-install emitter and check it is working. 2. Check the filter screen and gasket for any possible leakage and replace if required, .
Reduced flow of water from emitter.	1. Clogged filter 2. Pipe leakage 3. Open end cap	1. Clean filter screen. 2. Repair pipe leakage as mentioned above. 3. Tighten the end cap.

Every plant has its specifications and dimensions, which is why we cannot give a plan for the "perfect" plant. Focus your attention on every small motion that the masons do, thinking through step by step how could you place every action as in a industrial chain where every action is designed to be more efficient and less tiring, with less transportation of heavy elements and offering the best safety for workers.

# Shelter



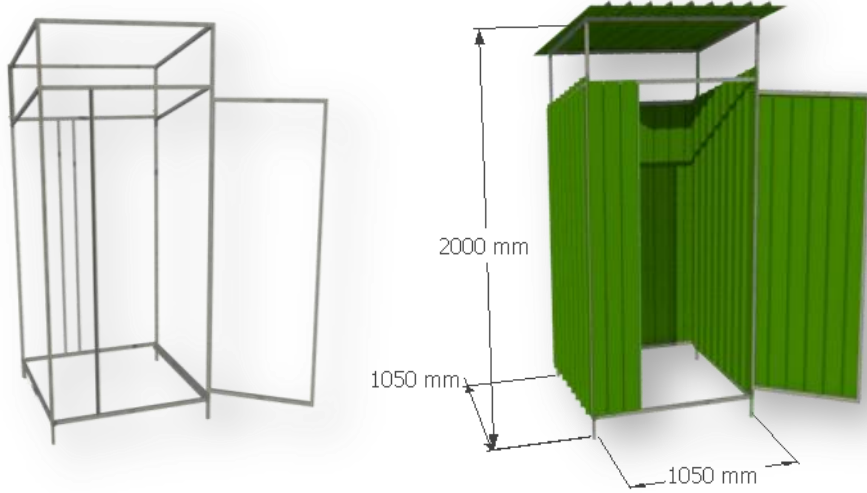

As Cambodia is located in the monsoon region, it is necessary to make the shelter resistant to strong winds. Moreover, the shelter needs to be transportable and easy to assemble. To manufacture it, we need:

- 4 sheets of Corrugated iron plate of 3 x 0.7 m
- 5 Stainless 6m long square steel bar of 20 x 20 x 2 mm
- Half box of rivets
- 12 pieces of bolts of 5cm long



Latrine shelter frame

Completed Shelter

Materials	Quantity	U-Price (Riel)	Total (Riel)	Total (USD)
Corrugated Iron Sheet 3x0.7m 	4 sheet	14700	58800	15
Rivet 	0.5 box	20000	10000	2
Stainless Cube Steel Bar 20x20x1cm 	5 bar	8300	41500	10
Bolt of 5cm long 	14 pcs	1000	14000	3
<b>Total</b>			124300	30

The shelter is made out of five flat elements that are manufactured separately then joined on the top of the slab. This makes it easy and quick to manufacture, store, transport, and easy for villagers to install themselves.

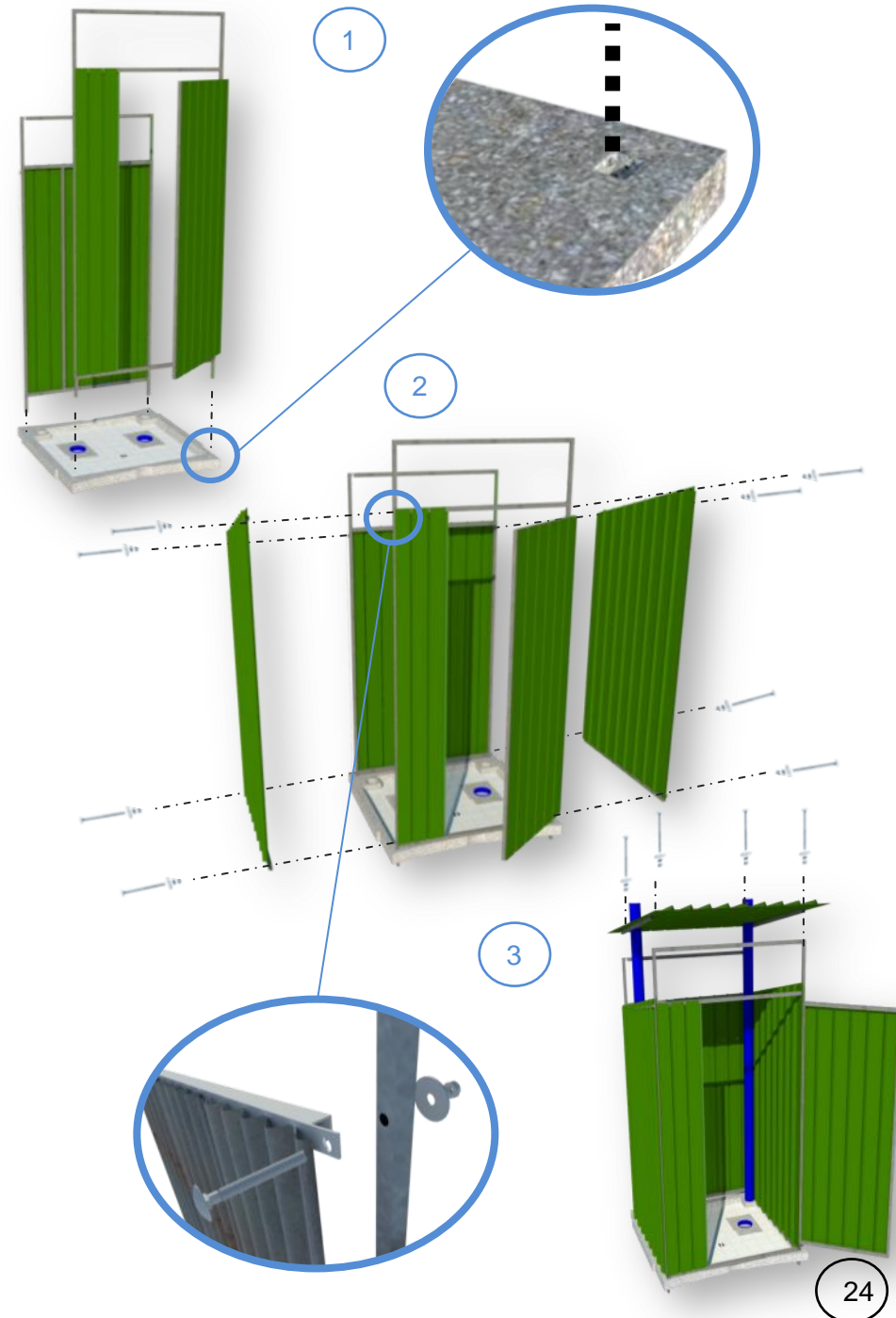

## Production methods

To build every component, a concept of "pattern" has been developed. It is basically assembled bar which will guide the shelter frame 2 x 2 cm square bars in order to manufacture the structure easy, quick, consistent and standardized. The pages 23 to 31 are dedicated to the dimension of these patterns.

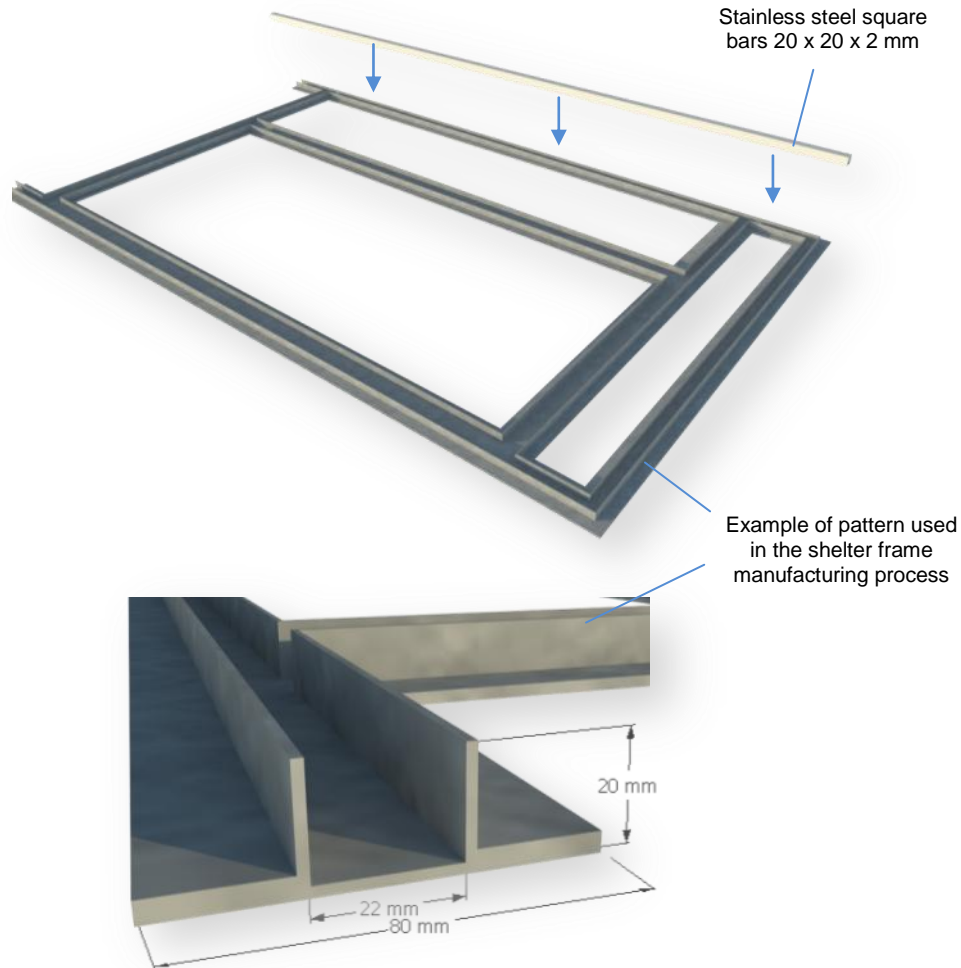

To prevent the pattern away from rusting, it is important to buy stainless bars, paint them and keep them covered when not in use.



The production steps are the following:

**STEP 1** Use the shelter pattern to measure the length for the shelter frame by placing the steel pieces into the pattern and cut to the length of the pattern (1).

**STEP 2** For the horizontal frame pieces, on the ends of the steel cut off only 3 sides of the steel and leave at least 25 mm of excess length on one side. This extra steel at the end will be used to attach pieces together (2).

**STEP 3** When all of the pieces have been cut, drill a hole through both bars to connect. Make sure the hole is the same diameter as the head rivets (3).

**STEP 4** Secure rivets in the drilled holes to attach together all of the pieces (4).

Then cut corrugated iron following the instruction on following chapter [Corrugated iron cutting model p30](#).

**STEP 5** Attach the corrugated iron to the each of the four walls of the shelter frame by drilling holes through the corrugated iron and the shelter frame and attaching them together using rivets. Attaching the corrugated iron to the frame makes the finished shelter stable and strong (5).



The choice of making the shelter 0.7 x 1.05 m on the ground has been made because in Cambodia the standard width for corrugated iron is 0.7 m. Corrugated iron is the most expensive part of the shelter, as you can see from p 30, corrugated iron cutting pattern. In other countries, other dimensions can be taken depending on the size of locally sourced materials, and keeping the spirit of the design.

## Shelter production Initial Investment

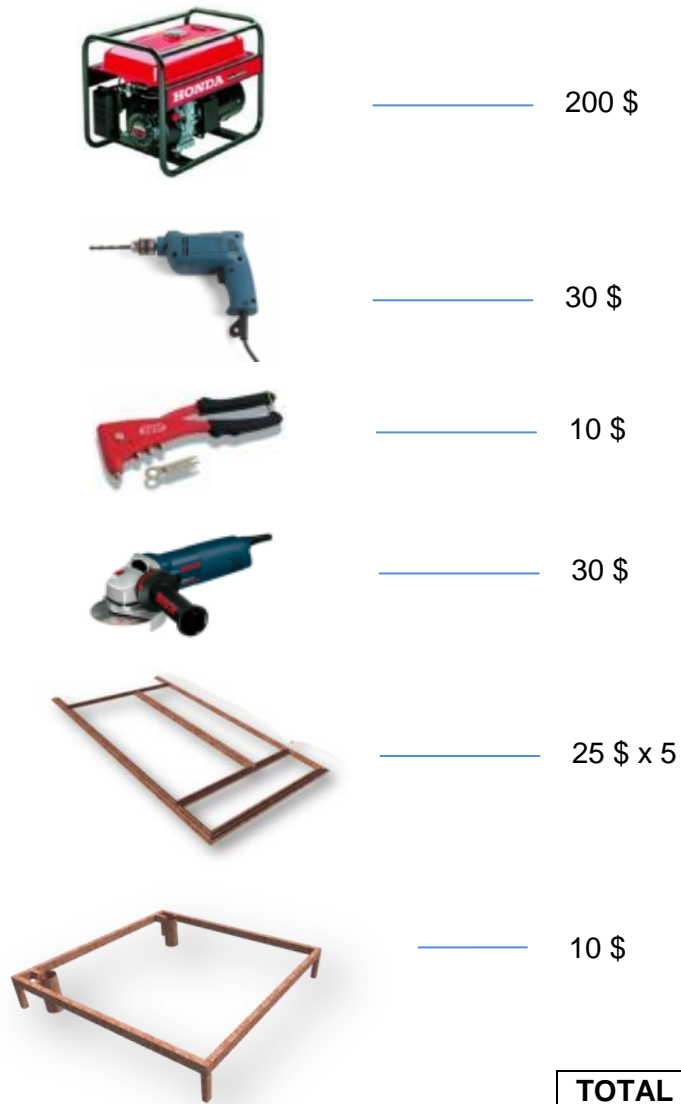

An electric welding machine would allow the mason to build the shelter elements much quicker but represent an extra investment.

## Lid and ventilation pipe

An important part of the shower is the pit lid because if it doesn't remain rain-proof over time the feces will get humid and will smell very bad, compromising the whole system. In Cambodia we use the same corrugated iron as for the shelter but several techniques are possible according to what materials are easy to obtain in the area of implementation.

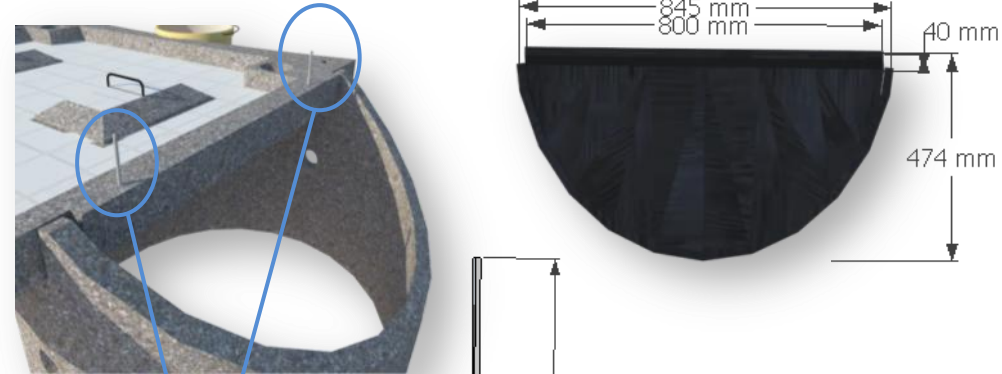

Screws (bolts) inserted into the concrete slab before the concrete is set

The small square bar (845 mm long) is fixed onto the horizontal part of the slab with screws (nuts and bolts, see diagram above) and riveted to the pit lid. The long square bar is fixed with rivets on the curved underside edge of the pit lid (as shown diagram below). It can be bent to fit the lid curve by making small cuts every 5 cm on one side with a cutting machine. The two bars are not connected, enabling the lid to lift up. A bicycle inner tube is cut and fixed to the long bar on the underside of the pit lid, to come between the lid and the concrete, thus providing extra water-proofing.

The top of the ventilation pipe needs to be covered to prevent rainwater entering the pit. A simple method is to fix a T pipe on the top to provide air flow and make sure water doesn't enter.

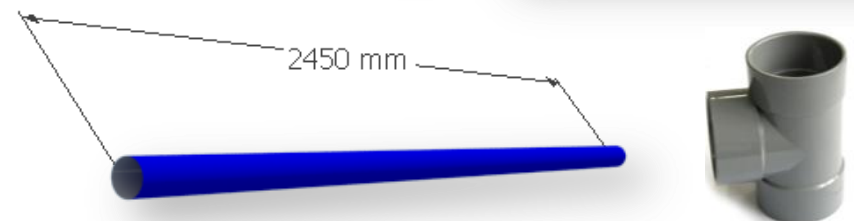
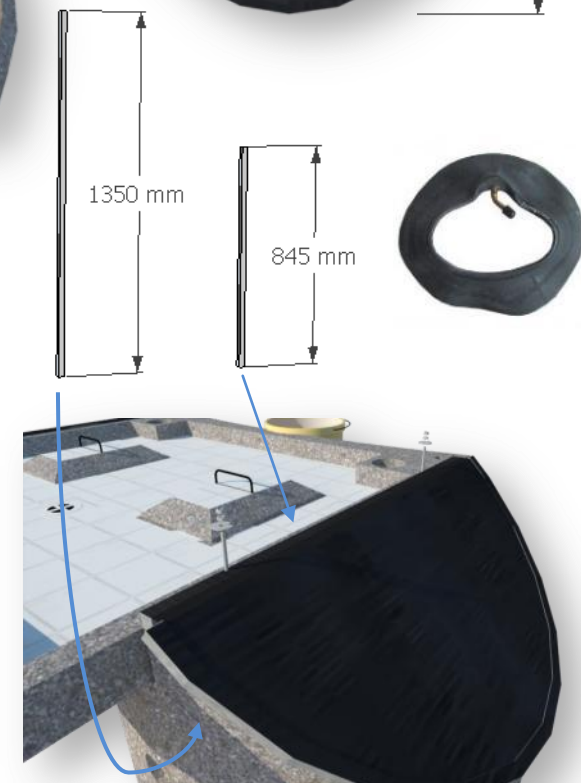

## Pattern for Front Wall

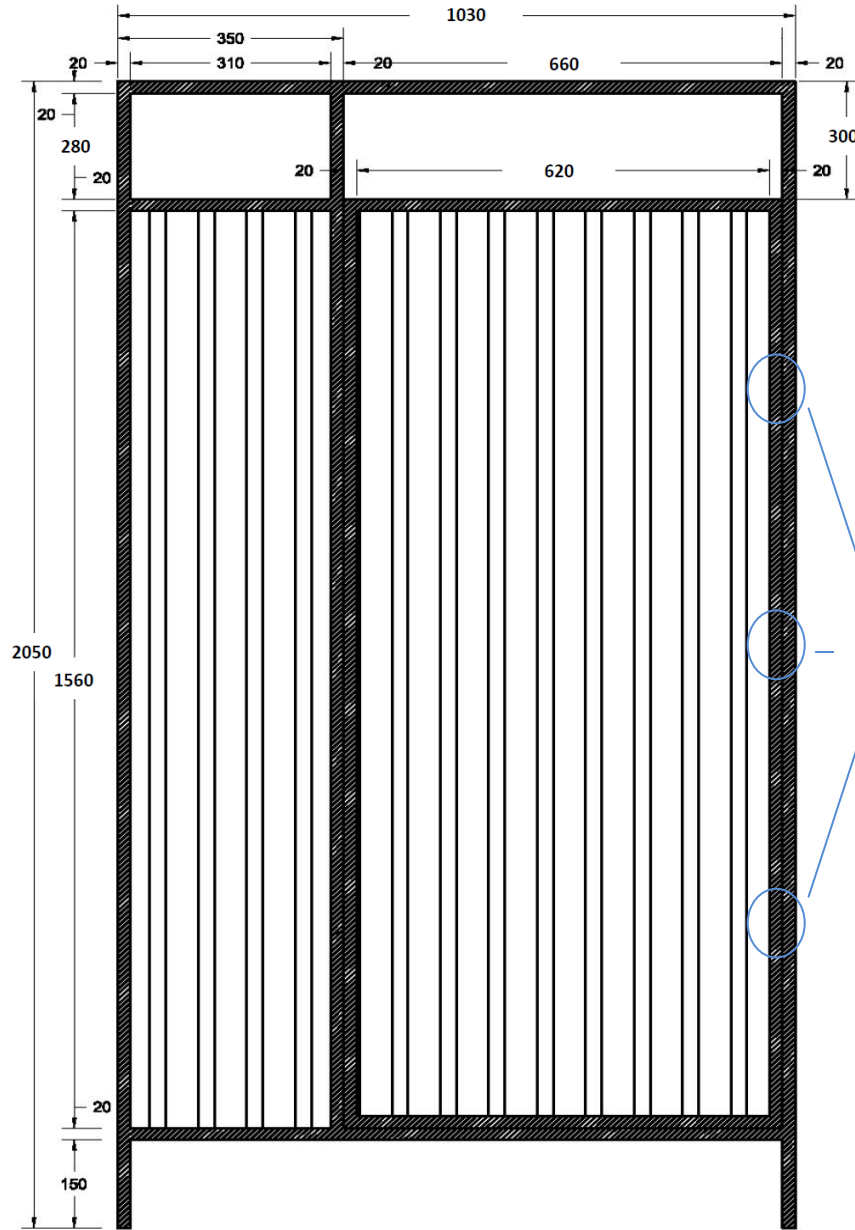

All dimensions are in millimeter unless otherwise stated

## Pattern for Roof

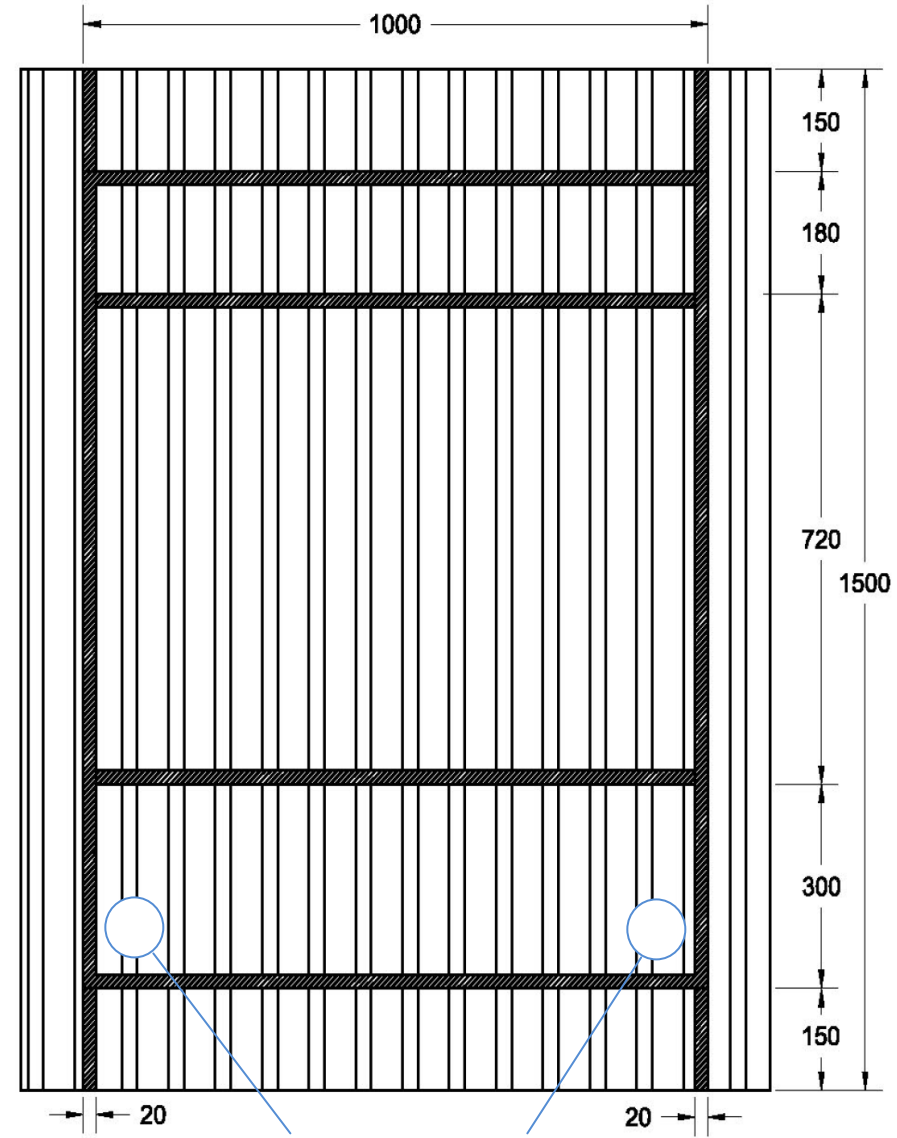

Holes for vent pipes  
Dia 80 mm  
Spaced of 795 mm



Pattern for Back wall

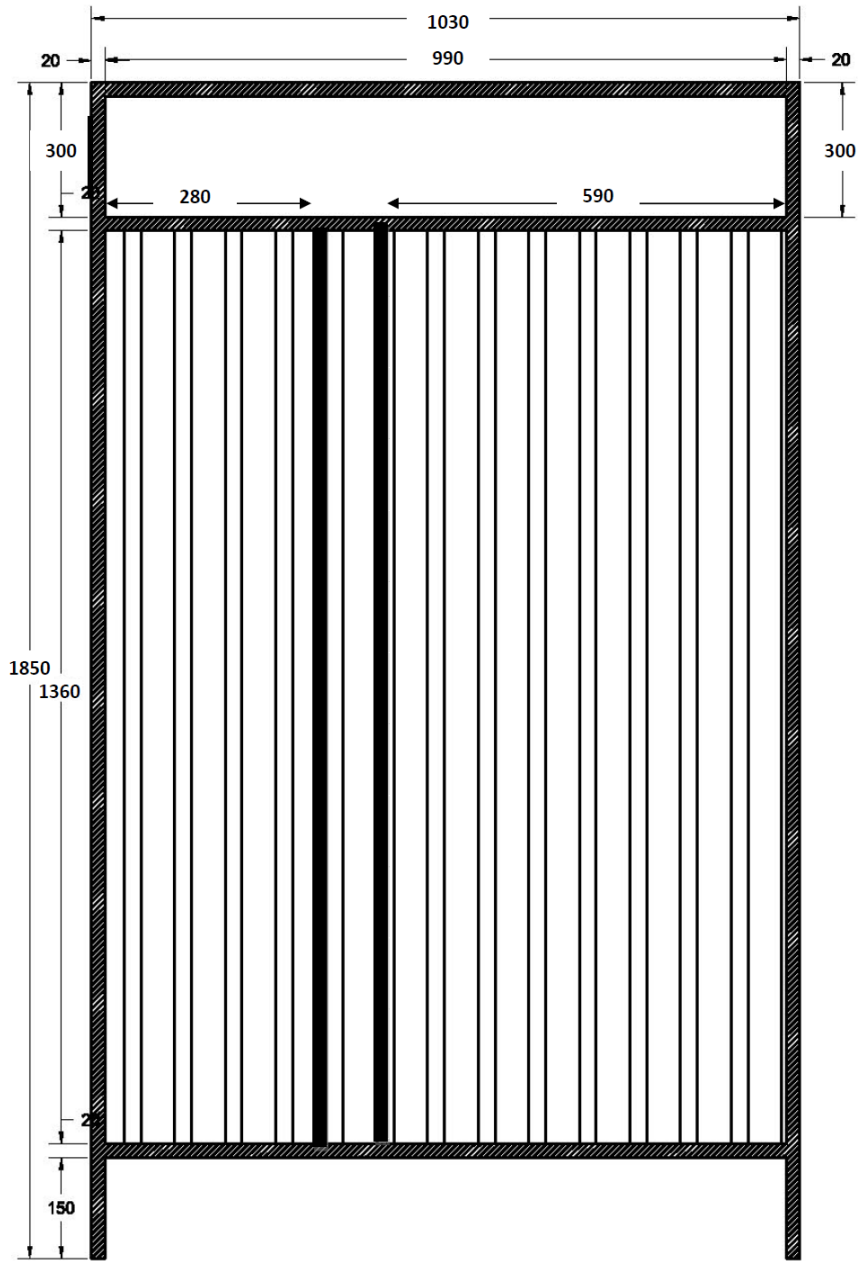

Pattern for left side wall

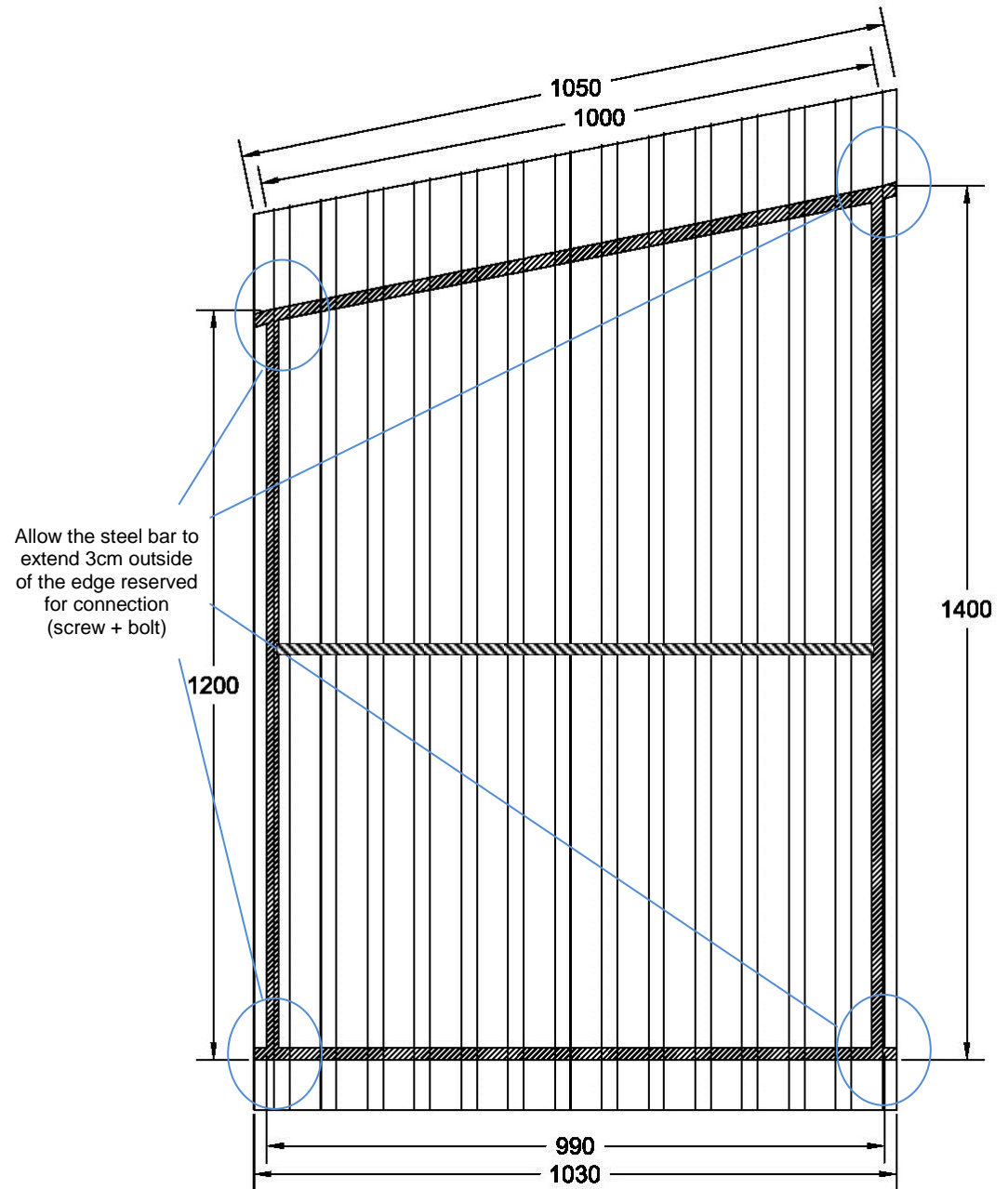

## Pattern for right side walls

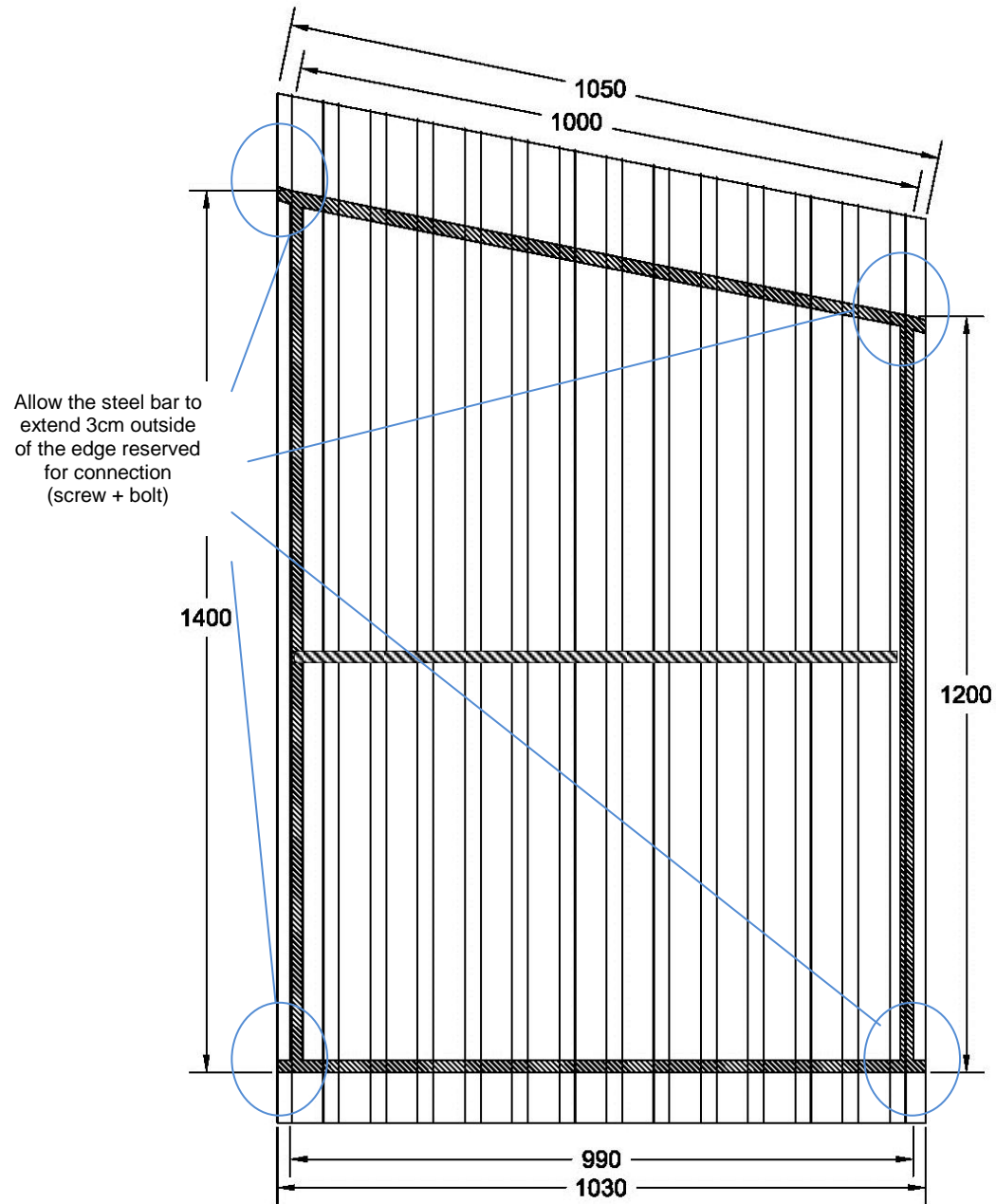

## Corrugated iron cutting models

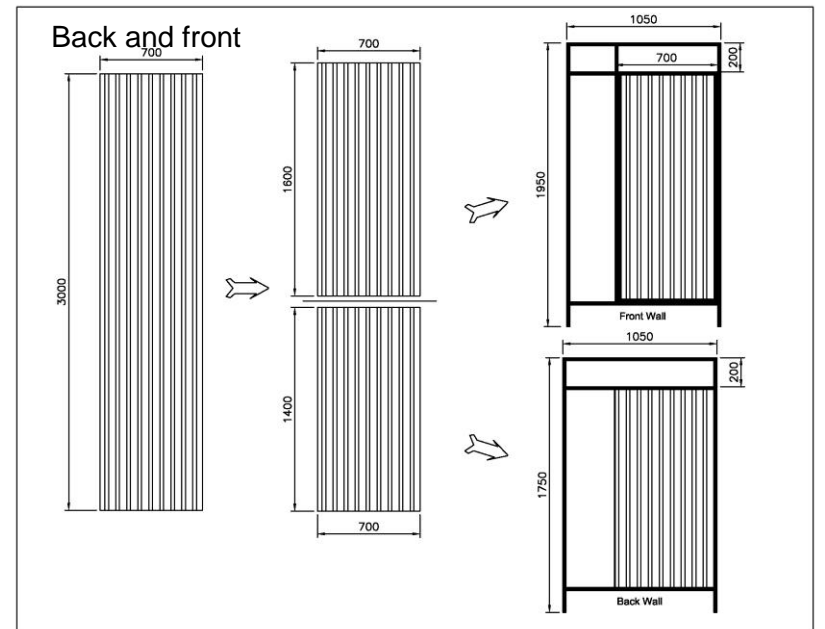
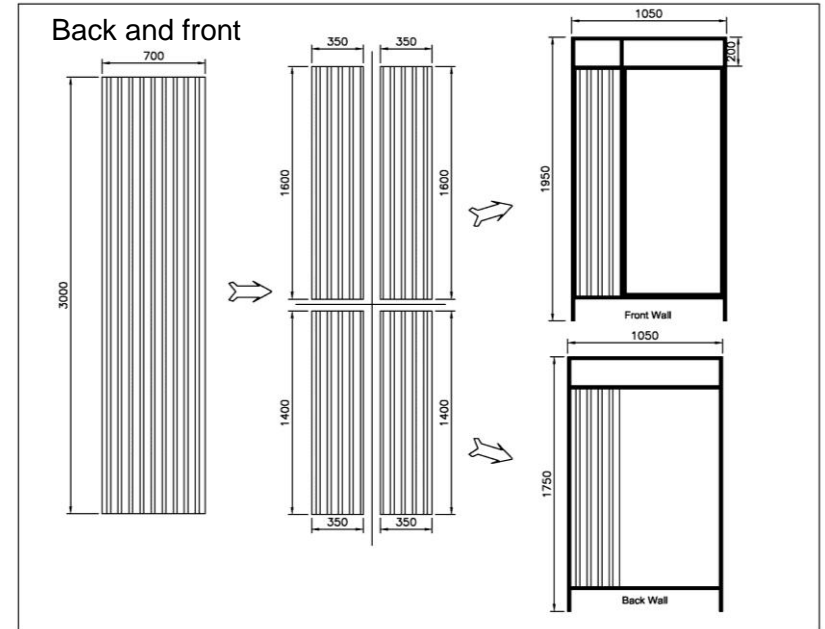

Sides

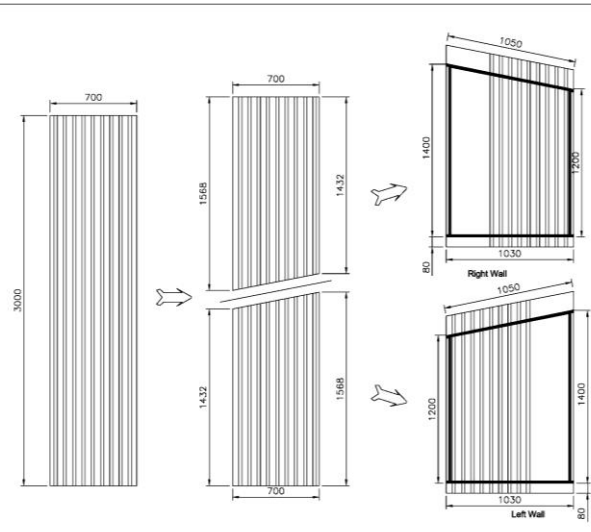
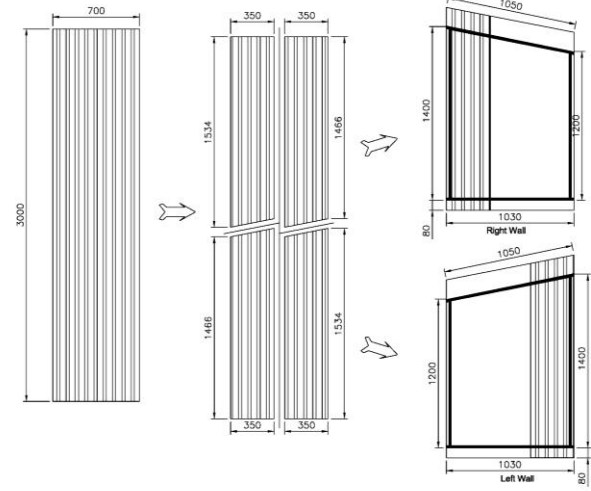

Roof

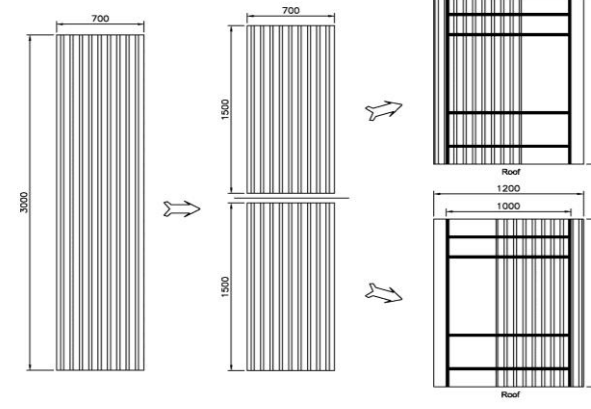

Handout / "Do It Yourself" leaflets

