



Biogas Sanitation Systems

Heinz-Peter MANG & Ina Patricia JURGA

Institute of Energy and Environmental Protection (IEEP)

Chinese Academy of Agricultural Engineering (CAAE)

E-mail: mang@ieep.net



International Conference on **eco**  **san**

I N D I A



Sanitation Strategies with Water Consumption

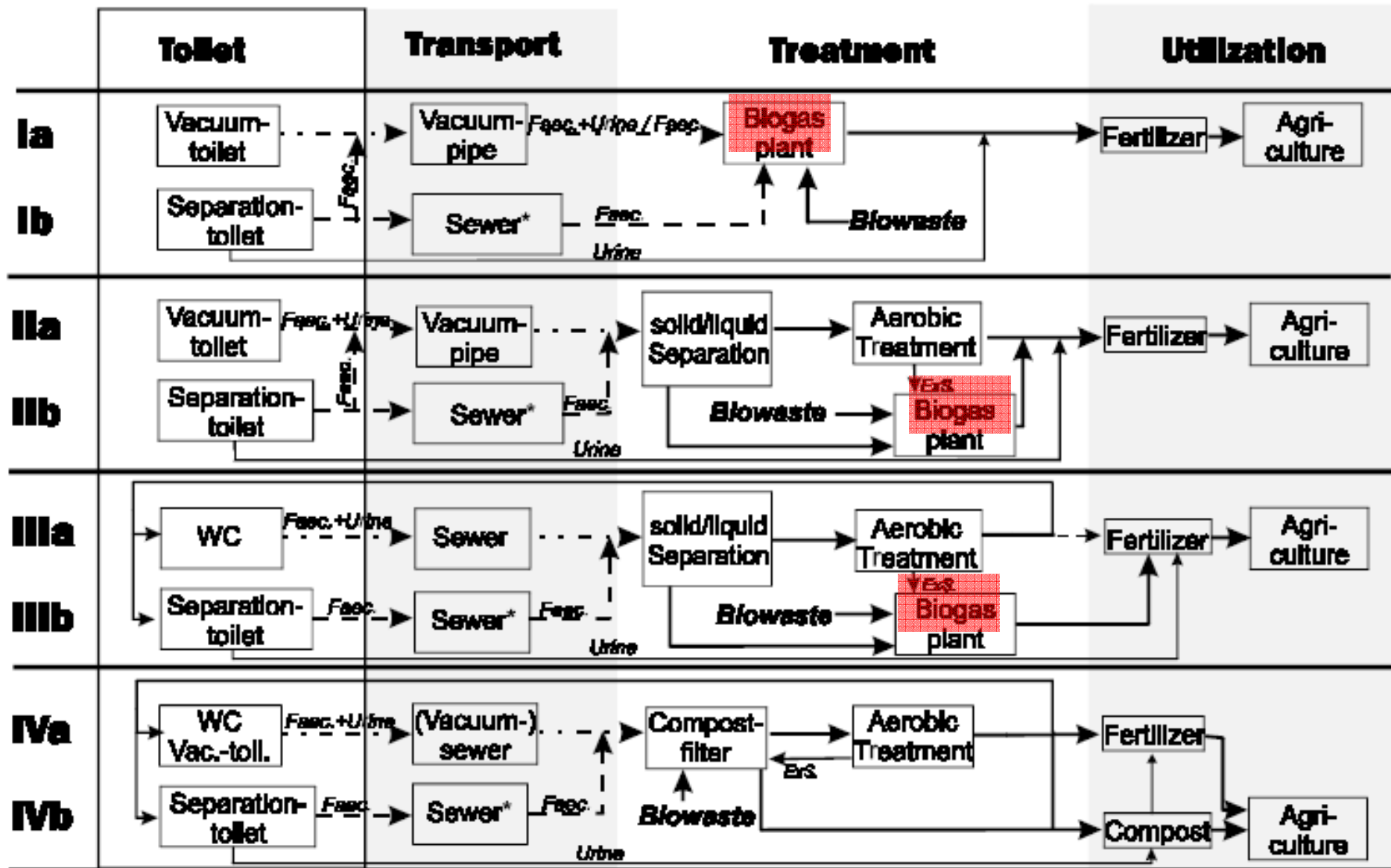

*Sewer: flush sewer, pressure or vacuum sewer

中国科学院工程热物理研究所能源环境技术研究中心

Sanitation Strategies without Water Consumption

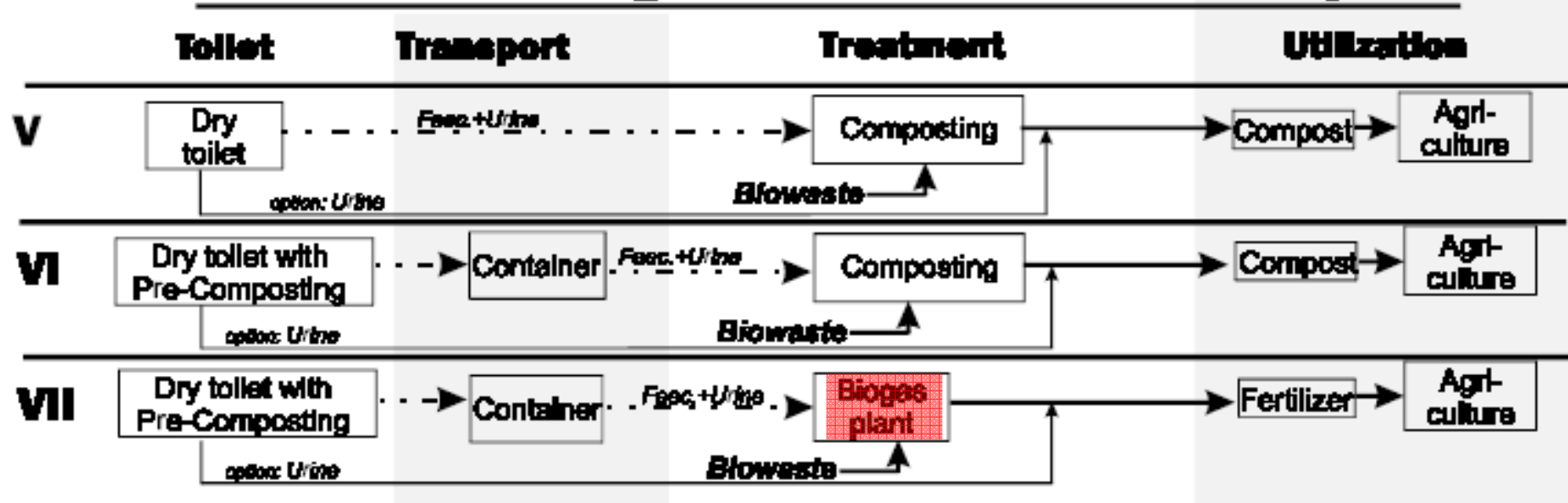

Low-Tech-Low-Cost Strategies for warm Climates

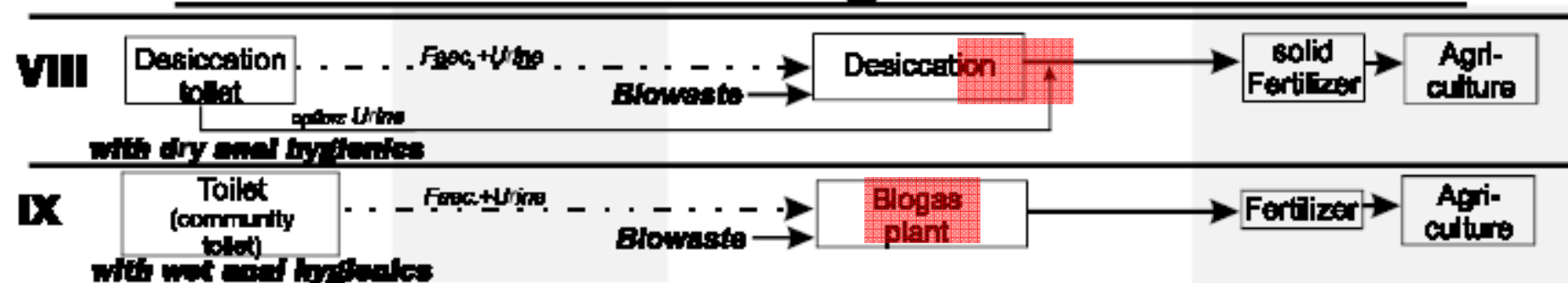

Forest- and Agriculture with whole-year-growing

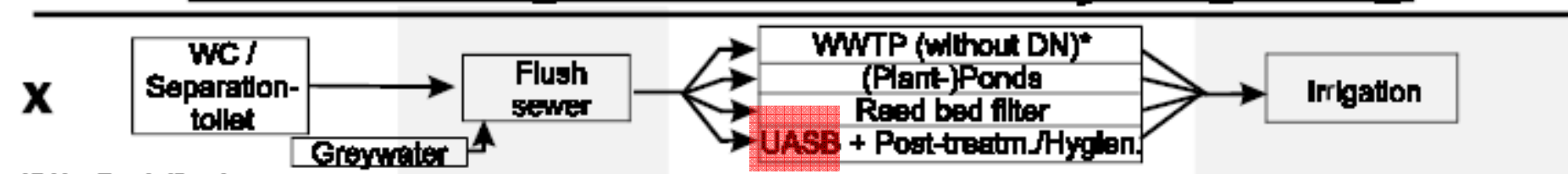

*DN = Denitrification



Basic ideas of Ecological Home and Prosperity Program

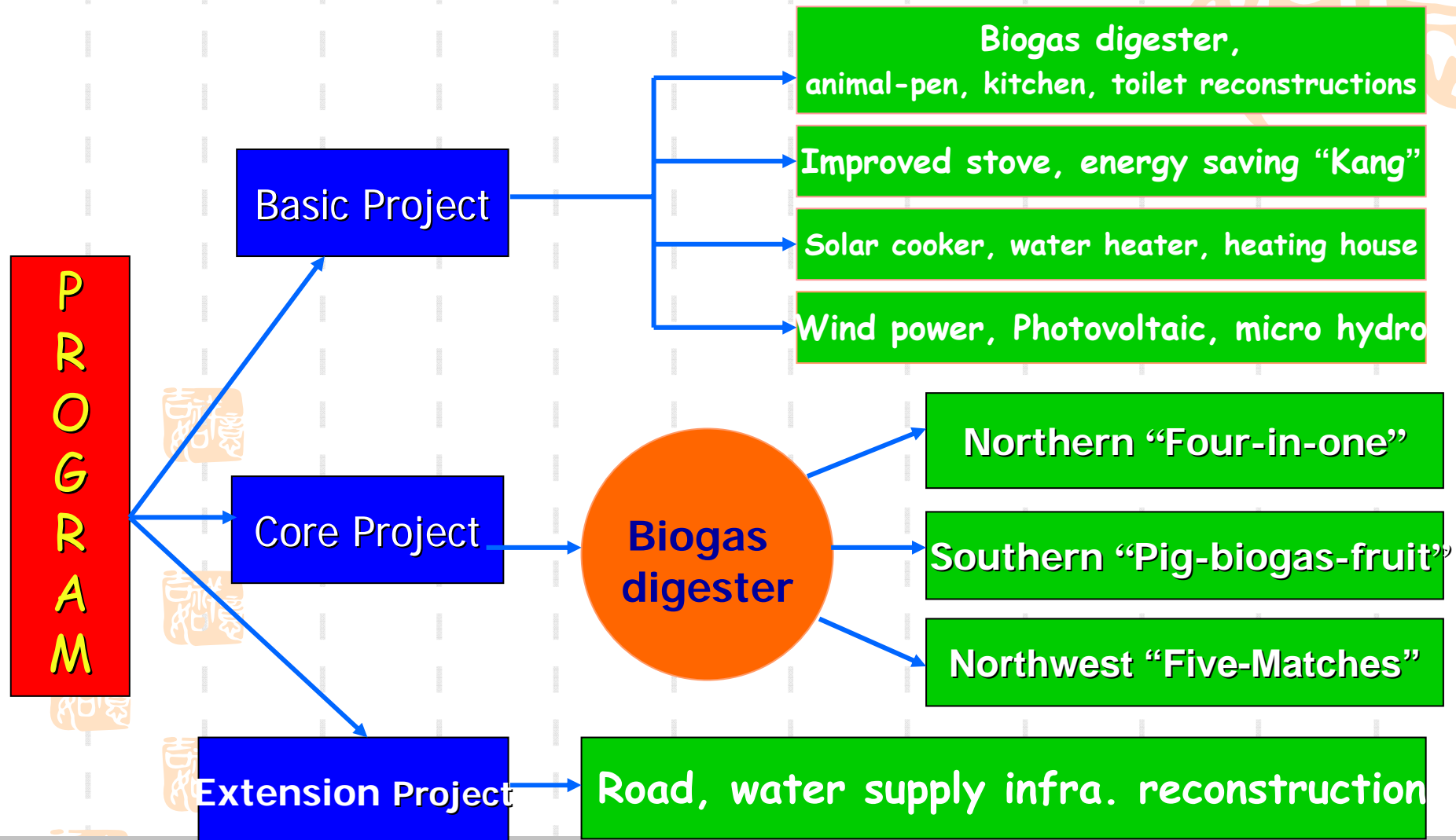

农业部规划设计研究院能源环保 - 农业部能源与环境技术开发中心

INSTITUTE OF ENERGY AND ENVIRONMENTAL PROTECTION (IEEP)
CENTER FOR ENERGY AND ENVIRONMENTAL PROTECTION TECHNOLOGY DEVELOPMENT (CEEPTD/MOA)



All organic materials can ferment or be digested:

faeces from cattle, pigs and possibly from poultry and humans, organic waste, energy crops, and organically loaded wastewater.

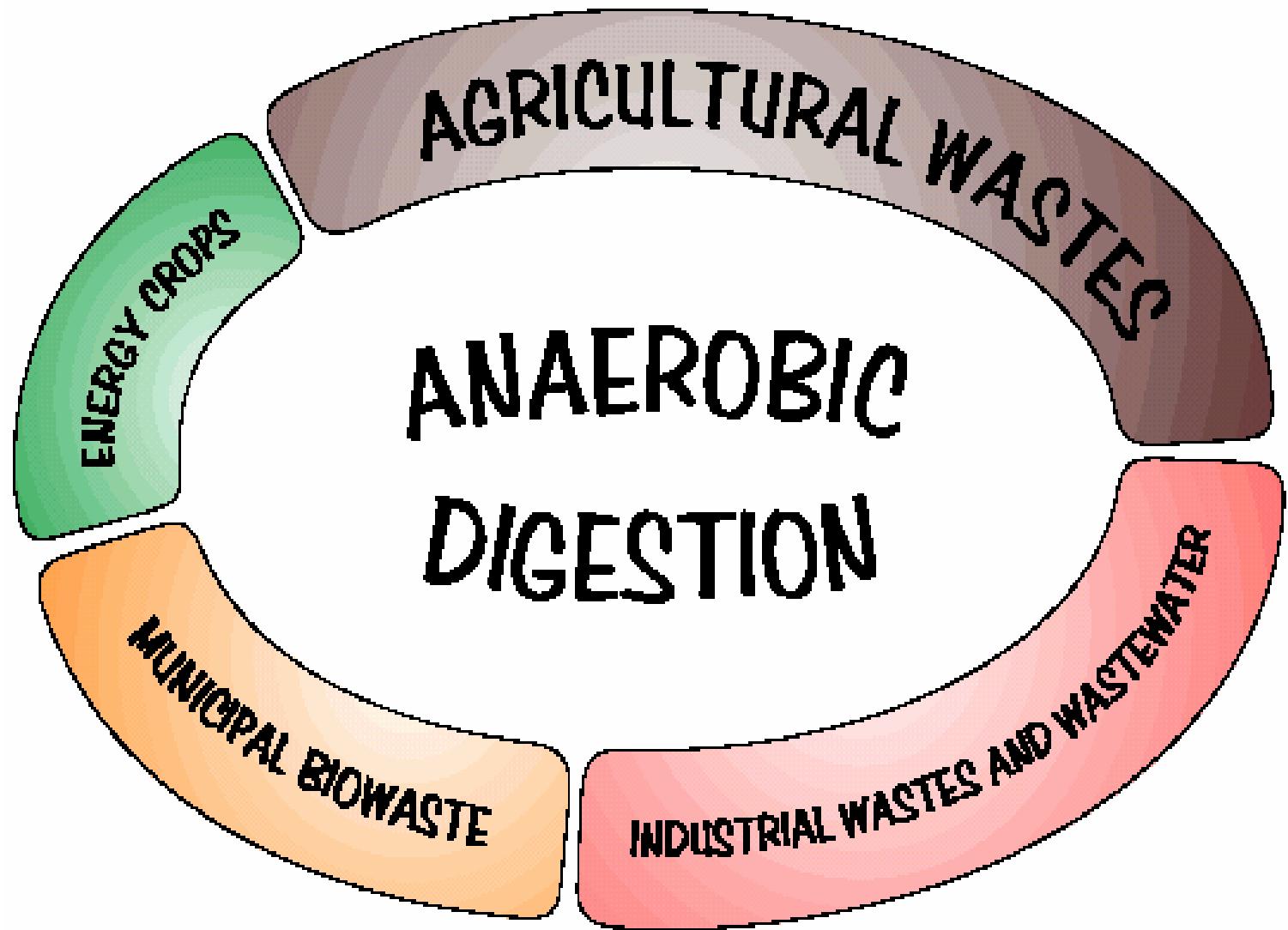

农业部规划设计研究院能源环保 - 农业部能源与环境技术开发中心

INSTITUTE OF ENERGY AND ENVIRONMENTAL PROTECTION (IEEP)
CENTER FOR ENERGY AND ENVIRONMENTAL PROTECTION TECHNOLOGY DEVELOPMENT (CEEPTD/MOA)

Diets higher in protein and lower in fibre, resulting in higher biogas production values!!!

Biogas potential



If the daily amount of available dung (fresh weight) is known, gas production per day will approximately correspond to the following average values:

- 1 kg cattle dung 40 litre biogas
- 1 kg buffalo dung 30 litre biogas
- 1 kg pig dung 60 litre biogas
- 1 kg chicken droppings 70 litre biogas
- 1 kg human excrements 60 litres biogas

The maximum of biogas production from a given amount of raw material depends on the type of substrate. As more biogas per unit produced, as better the BOD reduction.



If the live weight of all animals whose dung is put into the biogas plant is known, the daily gas production will correspond approximately to the following values:

- cattle, buffalo and chicken: 1,5 litres biogas per day per 1 kg live weight

农业部规划设计研究院能源环保 - 农业部能源与环境技术开发中心

INSTITUTE OF ENERGY AND ENVIRONMENTAL PROTECTION (IEEP)

ENERGY AND ENVIRONMENTAL PROTECTION TECHNOLOGY DEVELOPMENT (CEEPTD/MOA)

Amount cooked	Time (min)	Gas (L)
1 L water	10	40
5 L water	35	165
500 g rice	30	140
1000 g rice	37	175
350 g pulses	60	270
700 g pulses	70	315

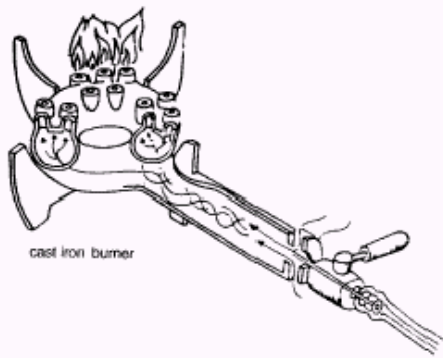
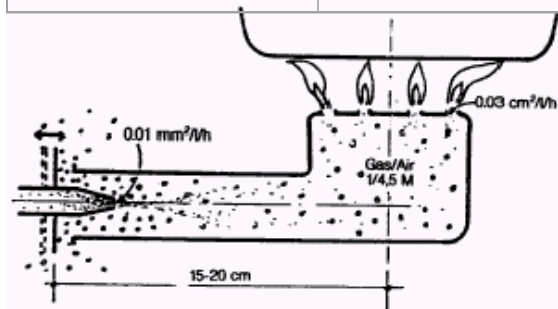

Equipment	Amount of biogas
Household burners	200 – 450 L/h
Industrial burners	1000 – 3000 L/h
Refrigerator 100 L depending on outside temperature	30 – 75 L/h
Gas lamp, equiv. to 60 W bulb	120 – 150 L/h
Biogas/biodiesel engine per bhp	420 L/h
Generation 1kwh electricity biogas/biodiesel or gas engines	500-700 L/h

1 m³ Biogas (approx. 6 kWh/m³) is equivalent to:

- Diesel, Kerosene (approx. 12 kWh/kg) 0.5 kg
- Wood (approx. 4.5 kWh/kg) 1.3 kg
- Cow dung (approx. 5 kWh/kg dry matter) 1.2 kg
- Plant residues (approx. 4.5 kWh/kg d.m.) 1.3 kg
- Hard coal (approx. 8.5 kWh/kg) 0.7 kg
- City gas (approx. 5.3 kWh/m³) 1.1 m³
- Propane (approx. 25 kWh/m³) 0.24 m³

农业部规划设计研究院能

Options for biogas utilisation

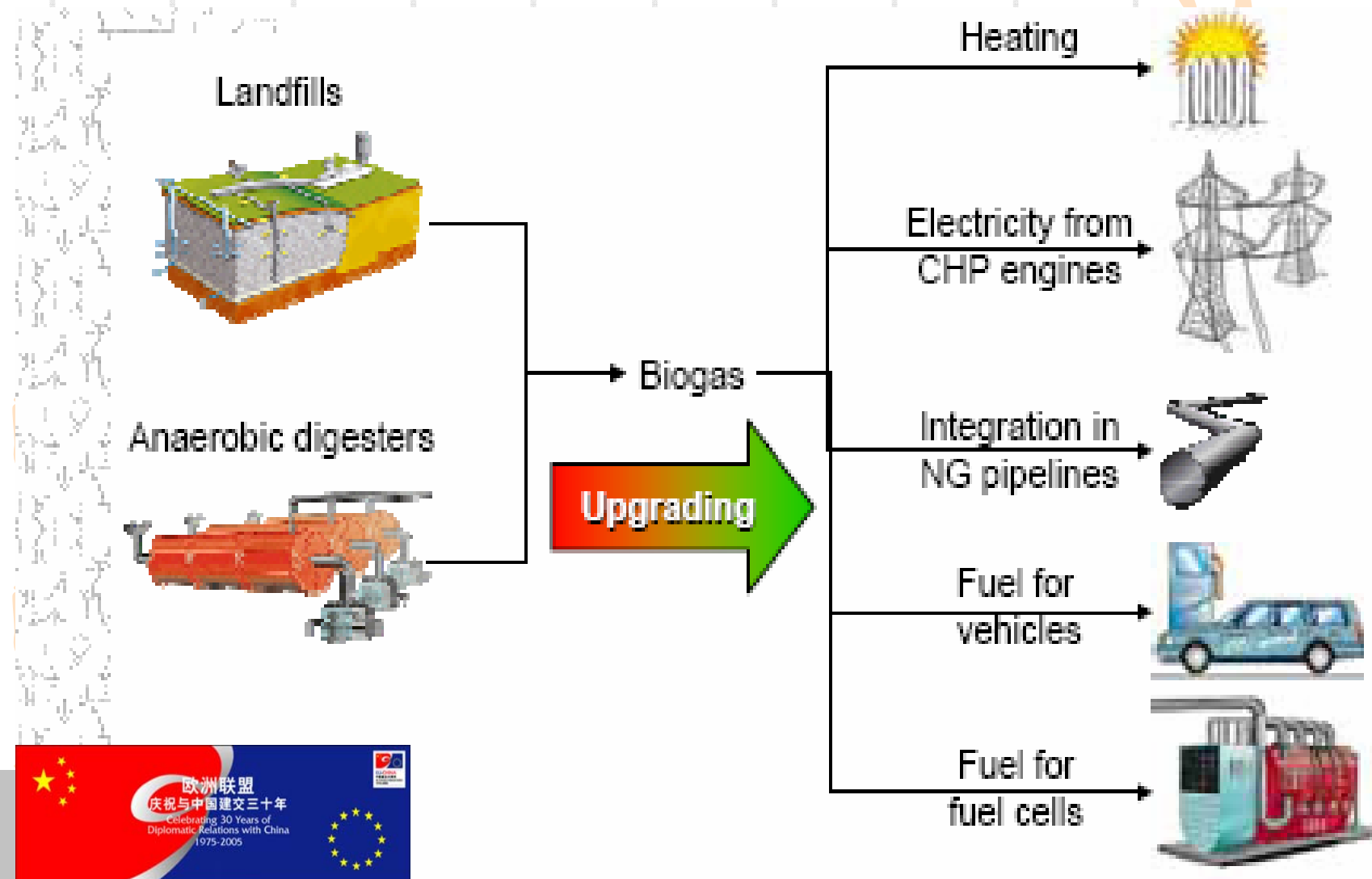



Biogas as fuel for waste incineration

- Waste incineration needs fossil fuel to burn waste in a rotating kiln; this could be partially replaced by biogas



农业部规划设计研究院能源环保 - 农业部能源与环境技术开发中心

INSTITUTE OF ENERGY AND ENVIRONMENTAL PROTECTION (IEEP)
CENTER FOR ENERGY AND ENVIRONMENTAL PROTECTION TECHNOLOGY DEVELOPMENT (CEEPTD/MOA)



Electricity from CHP-engines

- Gas-engine electricity generation needs medium-grade biogas purification (removal of moisture and trace gases)



农业部规划设计研究院能源环保 - 农业部能源与环境技术开发中心

INSTITUTE OF ENERGY AND ENVIRONMENTAL PROTECTION (IEEP)
CENTER FOR ENERGY AND ENVIRONMENTAL PROTECTION TECHNOLOGY DEVELOPMENT (CEEPTD/MOA)



Biogas feed in the natural gas grid

- Biogas needs to be high-graded with carbon-dioxide removal to natural gas standards.



农业部规划设计研究院能源环保 - 农业部能源与环境技术开发中心

INSTITUTE OF ENERGY AND ENVIRONMENTAL PROTECTION (IEEP)
CENTER FOR ENERGY AND ENVIRONMENTAL PROTECTION TECHNOLOGY DEVELOPMENT (CEEPTD/MOA)



Biogas as fuel for vehicles



This option needs high-upgraded biogas with a quality compared to LNG/CNG



农业部规划设计研究

INSTITUTE OF ENERGY

CENTER FOR ENERGY AND ENVIRONMENTAL PROTECTION TECHNOLOGY DEVELOPMENT (CEEPTD/MOA)

农业部能源与环境技术开发中心

ENVIRONMENTAL PROTECTION (IEEP)

CENTER FOR ENERGY AND ENVIRONMENTAL PROTECTION TECHNOLOGY DEVELOPMENT (CEEPTD/MOA)



Biogas sanitation

Human excreta from dry or low flush toilets and biodegradable organic fraction of household waste could enter a (on-site or off-site) anaerobic (wet or dry) digester to be treated and to produce biogas.

For biogas plant regarded from an energy point of view, its better to have some animal manure or additional feed of organic waste, and to optimize the retention time related to energy output ./ construction volume.

For biogas as a sanitation option it is more important to look for the sanitization of the incoming black-, brown-, or wastewater and organic wastes. Therefore the input material stays longer in the digester, and the retention time will be adopted with an optimum of sanitation degree and biogas production.

农业部规划设计研究院能源环保 - 农业部能源与环境技术开发中心

INSTITUTE OF ENERGY AND ENVIRONMENTAL PROTECTION (IEEP)
CENTER FOR ENERGY AND ENVIRONMENTAL PROTECTION TECHNOLOGY DEVELOPMENT (CEEPTD/MOA)



Retention time

Under plug flow conditions - without post-treatment in wetlands or polishing ponds - the usual treatment of faecal sludge, properly applied by

1. anaerobic psychrophilic fermentation (above 10°C and retention times of at least 100 days),

2. mesophile digestion (above 30°C with retention times of at least 50 days) or

3. thermophile digestion temperature (above 55°C and about 10 days retention time),

can be considered as sufficient.

(volume ratio: 10:5:1)



Biogas from brown water

The concentration of nitrogen in the black water could be so high, that the digestion process could be stopped. Ammonia from the urine will be transformed by enzymes in urea, carbon dioxide and ammoniac. Urea will be toxic to the bacteria (self-intoxification).

This could be solved by solid/liquid separation (AQUATRON, filter bag, settler) or urine diversion toilet bowls and pans, and the “solid” part (faeces, sludge) are digested.



III. Benefits Achievable

- a) Social benefits
- b) Economic benefits
- c) Environment and ecological

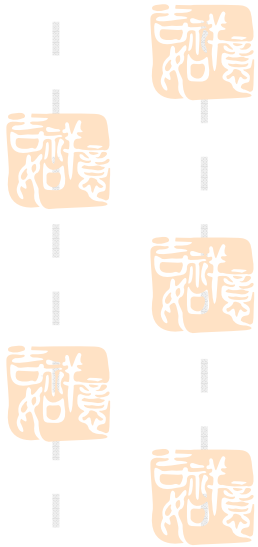



a) Social Benefits

- Job creation for local people
- Health improvement—disease reduction due to utilization of clean energy and end products use as land fertilizer
- Especially good for women
- Lifestyle improvement



Dispose of your waste water and save money doing it!

SRC upbeat about biodigester septic tank technology

By Petre Williams Observer staff reporter
Sunday, May 02, 2004

In the 1970s when the Germans introduced biodigester septic tank (BST) technology - a money-saving way to solve the acute waste water disposal practices in Jamaica - it was an idea whose time had not yet come.

Three decades later, the state-run Scientific Research Council (SRC) is getting ready to embark on an aggressive promotion of its biodigester septic tank system, hoping to cash in on the many spin-off benefits.

SRC executive director, Dr Audia Barnett, is enthusiastic about the technology: "You are treating your waste water. You are getting gas, which you can use for cooking. You are getting water you can use for irrigation and you are getting literally no waste," she told the Sunday Observer.



"There's practically no (need for) maintenance. It's a system that my staff likes to call 'set it and forget it'. It's not like the septic tank that you have to be pumping every now and again," Barnett said.

The SRC is reporting that there has been renewed interest in BSTs, as they are called. "We have seen a resurgence... of interest in our BSTs, both at the residential level and at the industrial level," said Barnett.





b) Economic Benefits—energy saving

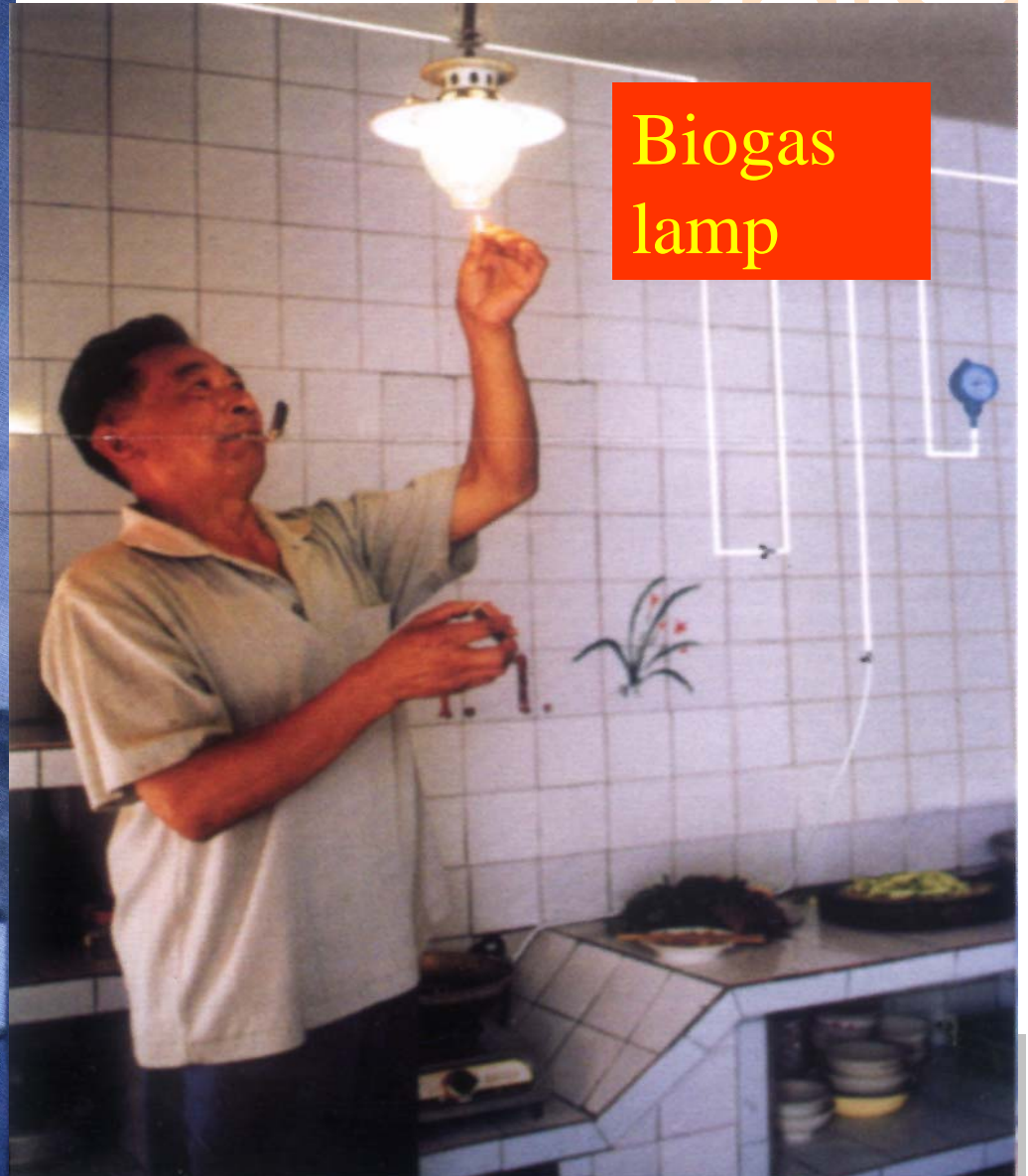

Energy Equivalent of Biowaste



有机垃圾所含能量



10 kg Kitchen waste
10公斤的厨余垃圾

1 m³ Biogas = 0.75 m³ Natural gas
1 m³ 的有机气体 = 0.75 m³ 天然气

1 l Gasoline, 1 升汽油

20 km Car mileage
可供一辆轿车行驶20 km



1 kg Biowaste = 2 km car mileage
1 kg 的有机废物 = 可供一辆轿车行驶2 km

Energy Content of Biogas 沼气的内能

In China the rural families can cover their energy demand by 60 % from Biogas produced from their own BW
中国农村家庭所需能量的60%可由自己家庭日常生活垃圾经处理产生的甲烷提供

One family (3 persons) produces about 4 kg Biowaste a week = Energy equivalent to 8 km car mileages

一个三口之家每星期产生4kg有机垃圾，其所含能量可供一辆轿车行使8km

The overall biogas production potential from 75 mill.t of Chinese BMW is equivalent to 4.5 billion m³ natural gas

农业废弃物综合利用技术示范工程 - 农业废弃物资源化利用技术示范工程



Biofuels and conversion

	% dry matter	Gas prod.	Combust.
Manure	7 - 12	+++	-
Black (brown) water	0.5 - 2	+	---
Sludge	25 - 50	++	+/-
Slaughter waste	40 - 60	++++	++/-
Wet organic waste	20 - 50	+/-	+/-

**Energy in brown water per person per year
75 – 200 kWh net, biogas energy output**

GTZ, 1997 and NLH, 2003

**Diets higher in protein and lower in fibre,
resulting in higher biogas production values!!!**

Avoid indoor air pollution



改厨



Anaerobic sanitization

(BRTC, China 1985)



Pathogens & parasitic ova	Thermophilic fermentation (53-55 degrees C)		Mesophilic fermentation (35-37 degrees C)		Ambient temp. fermentation (8-25 degrees C)	
	days	Fatality (100%)	days	Fatality (100%)	days	Fatality (100%)
<i>Salmonella</i>	1~2	100	7	100	44	100
<i>Shigella</i>	1	100	5	100	30	100
<i>Polioviruses</i>			9	100		
<i>Colititre</i>	2	$10^{-1} \sim 10^{-2}$	21	10^{-4}	40~60	$10^{-4} \sim 10^{-5}$
<i>Schistosoma ova</i>	Several hours	100	7	100	7~22	100
<i>Hookworm ova</i>	1	100	10	100	30	90
<i>Ascaris ova</i>	2	100	36	98.8	100	53

农业部规划设计研究院能源环保 - 农业部能源与环境技术开发中心

INSTITUTE OF ENERGY AND ENVIRONMENTAL PROTECTION (IEEP)
CENTER FOR ENERGY AND ENVIRONMENTAL PROTECTION TECHNOLOGY DEVELOPMENT (CEEPTD/MOA)



Reduction of pathogens

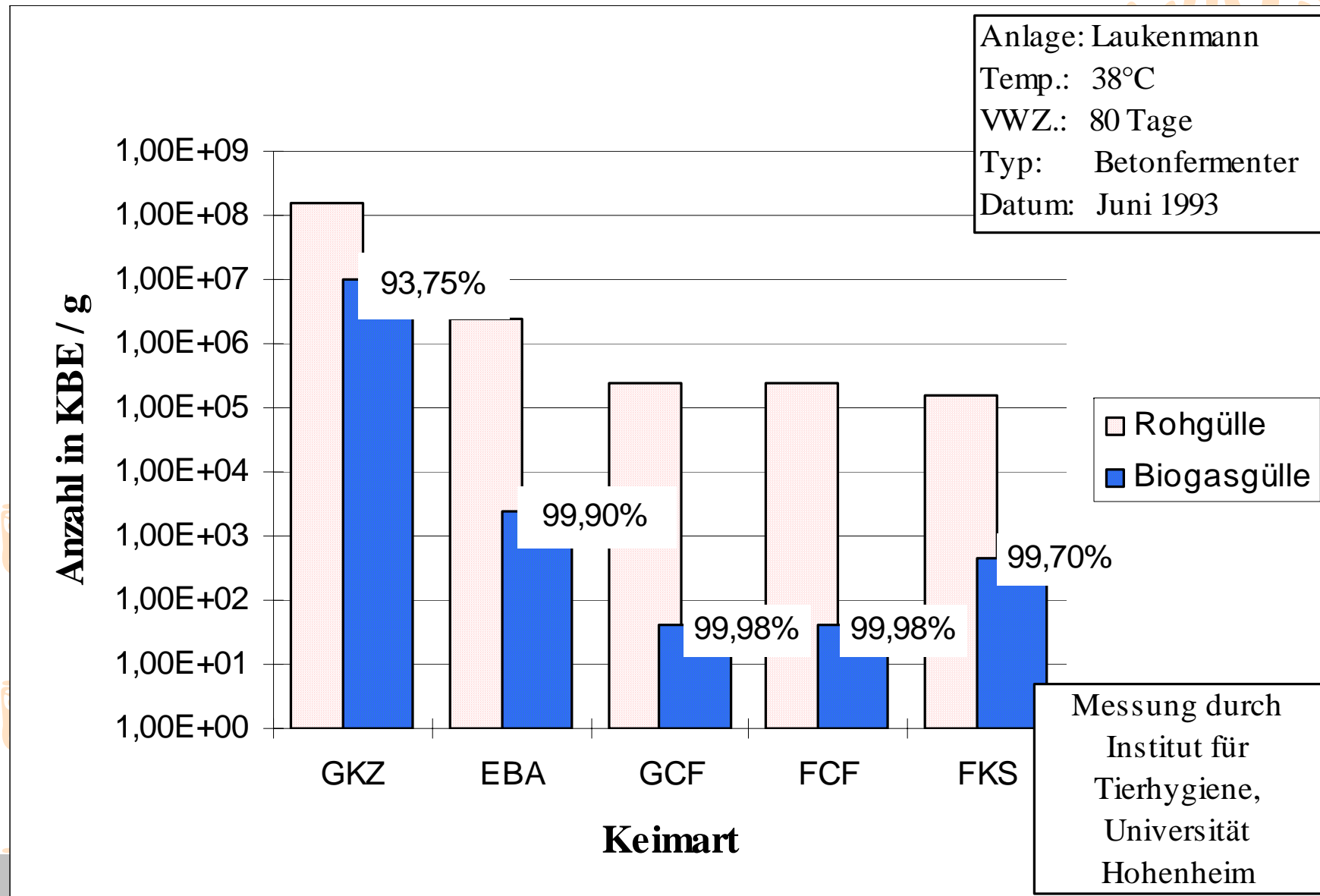

Smell reduction through digestion

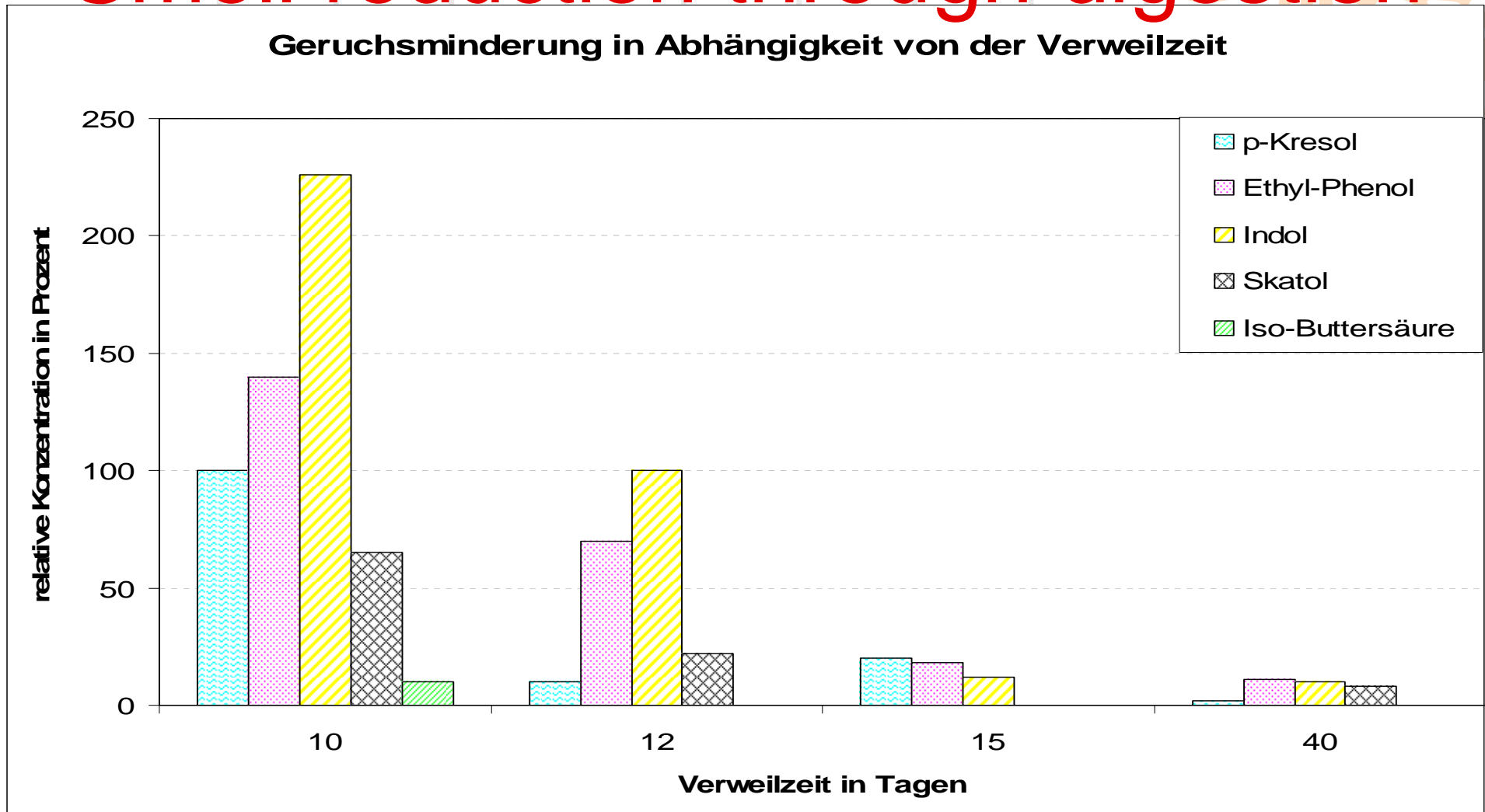



b) Economic Benefits

- Energy saving
- Farm development
- Various use of end product



b) Economic benefits---income increase

Model	Pure benefit yearly (unit: yuan)
Household biogas	600
Northern “four-in-one”	3000
Southern “pig-biogas-fruit”	2000



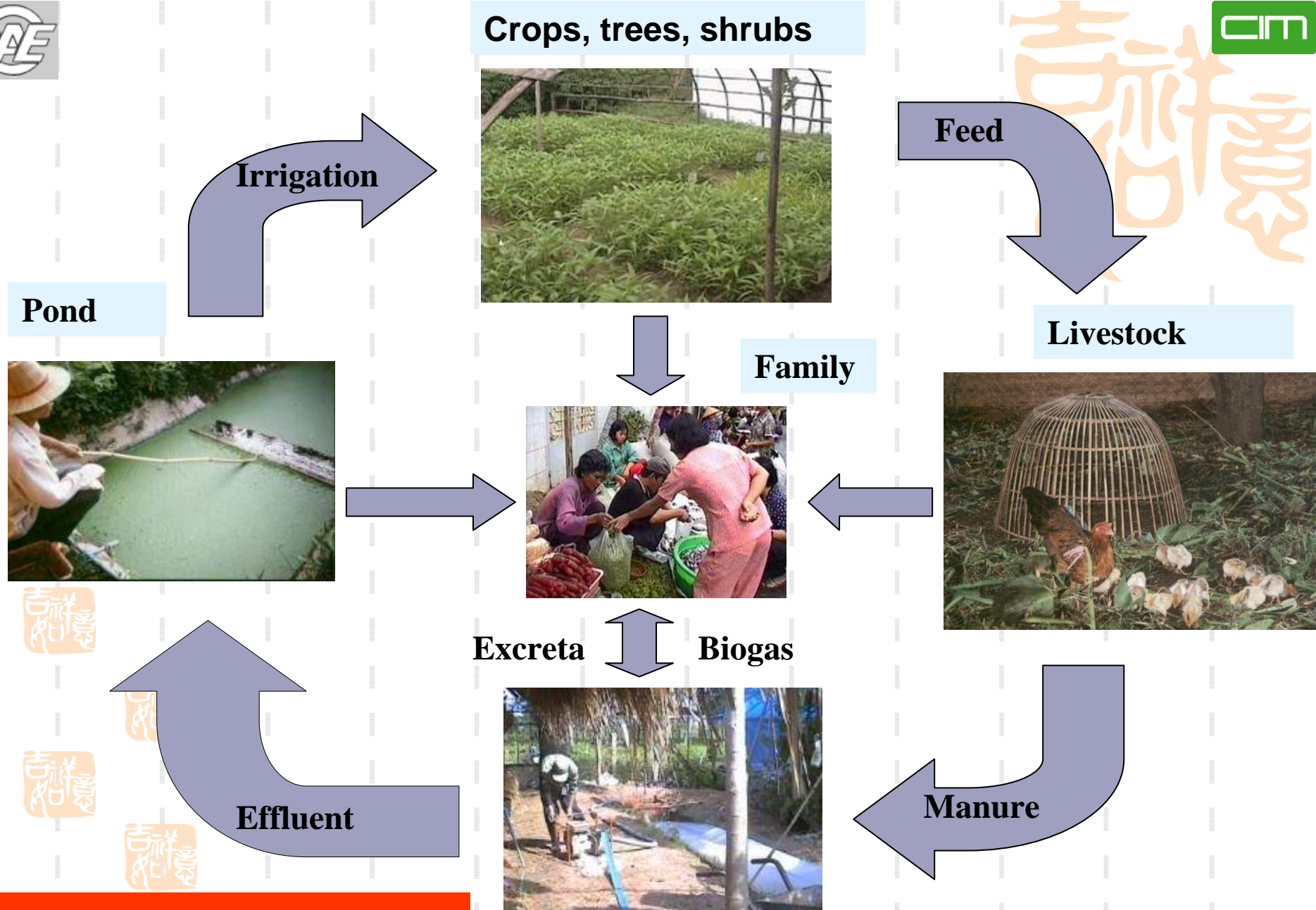

The ecological farm

院能源环保 - 农业部能源与环境技术开发中心

INSTITUTE OF ENERGY AND
CENTER FOR ENERGY AND ENVIRONMENTAL

Biodigester

AL PROTECTION (IEEP)
OGY DEVELOPMENT (CEEPTD/MOA)

Pig-pen improvement



沼气储粮
grain stored by biogas



沼渣种菇
mushroom planted with digested sludge

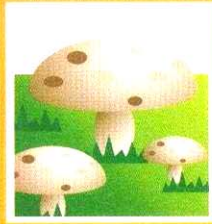

沼液养鱼
fishes fed with digested slurry



水果保鲜
fruits stored by biogas



沼液浸种
seeds soaked with digested slurry

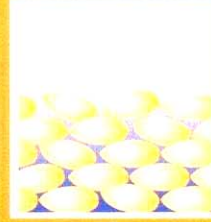

沼液喂猪
pigs fed with digested slurry

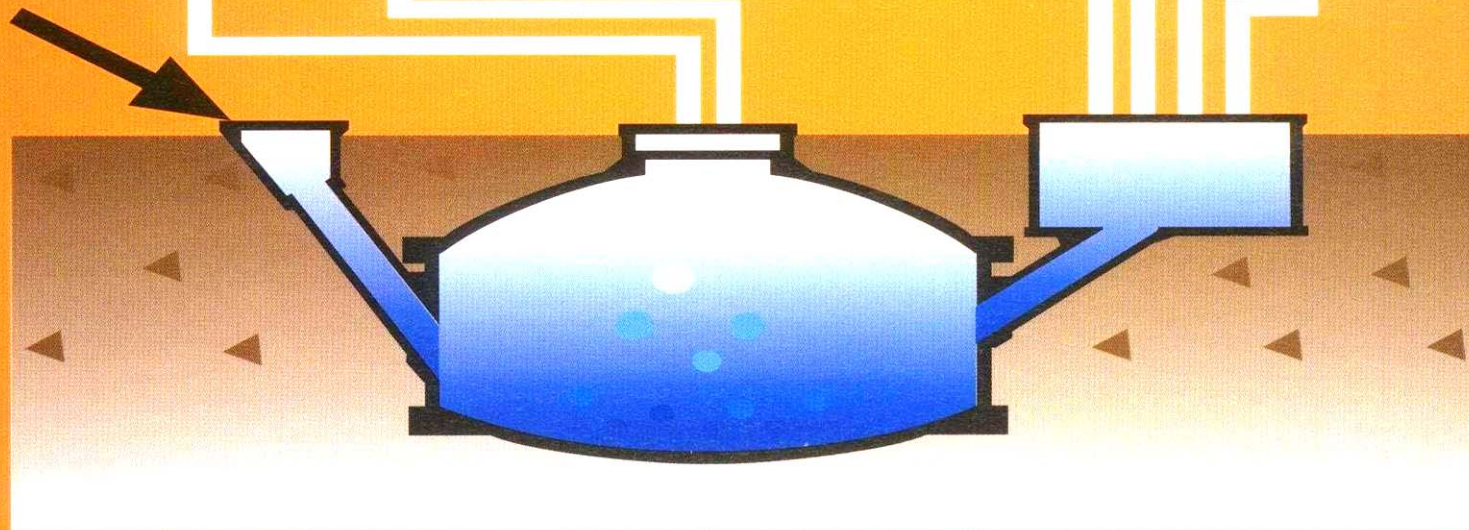

c) Environmental and ecological— protect forest



=





Fossil energy substitution

The use of biomass as a substitute for fossil fuel represents a high potential for the avoidance of GHG emissions.

One opportunity is associated with the processing of faeces or brown water, by which means biogas is obtained. The latter produces energy and at the same time reduces tradable

1) The Clean Development Mechanism (CDM) is a compensation mechanism. It allows industrial countries to obtain emission reduction credits with emission reduction projects in developing countries. The credits are called Certified Emission Reductions (CER). An Annex I country invests in a Non-Annex I Country and cooperates with private or public institutions. The accounting of such reduction credits starts

retroactively from the year 2000 onward.



Environmental benefits---CO₂ and CH₄ reduction

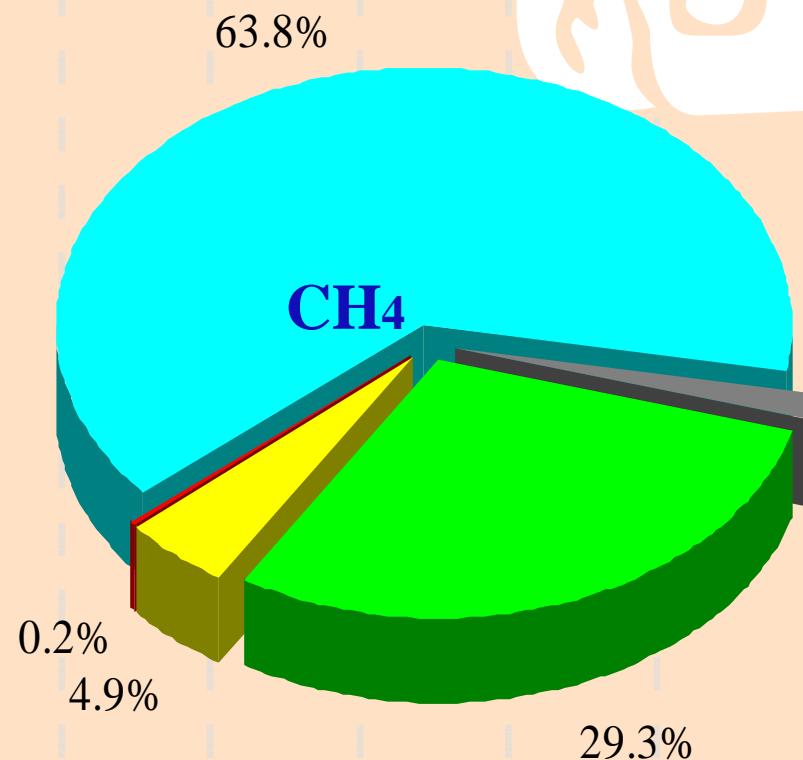
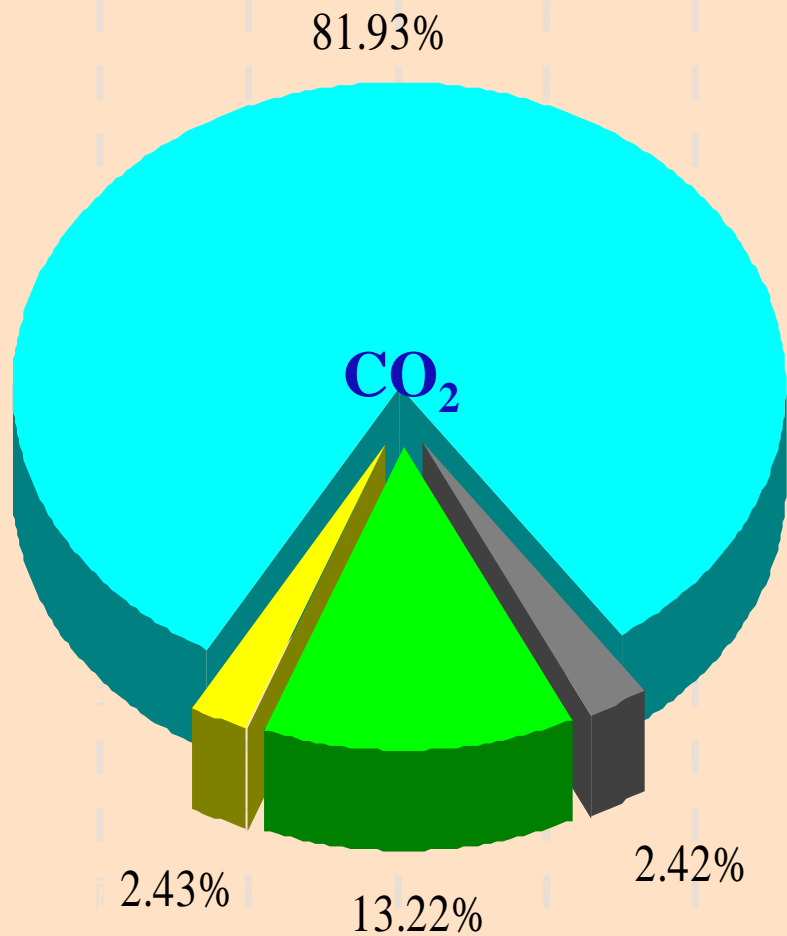

- improved stove
- energy-saving kang
- household biogas
- other

- 省柴灶
- 户用沼气
- 节能炕
- 大中型沼气工程
- 其它

农业部规划设计研究院能源环保 - 农业部能源与环境技术开发中心



Biogas for overall household sanitation

- decentralised treatment of household wastewater with or without agricultural and organic household, kitchen waste
- valuable nitrogen remains available

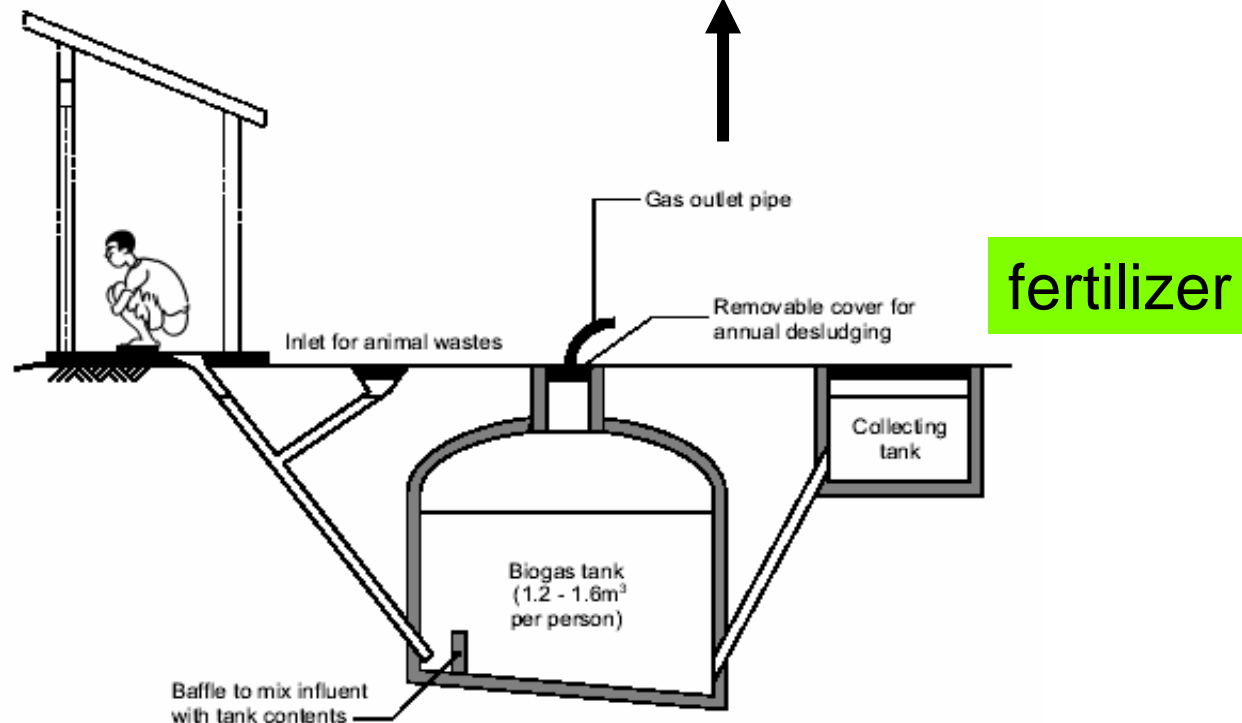



137,000 community biogas septic tanks (DEWATS) for purification of household wastewater with more than 0.5 billion tons of wastewater treated annually.

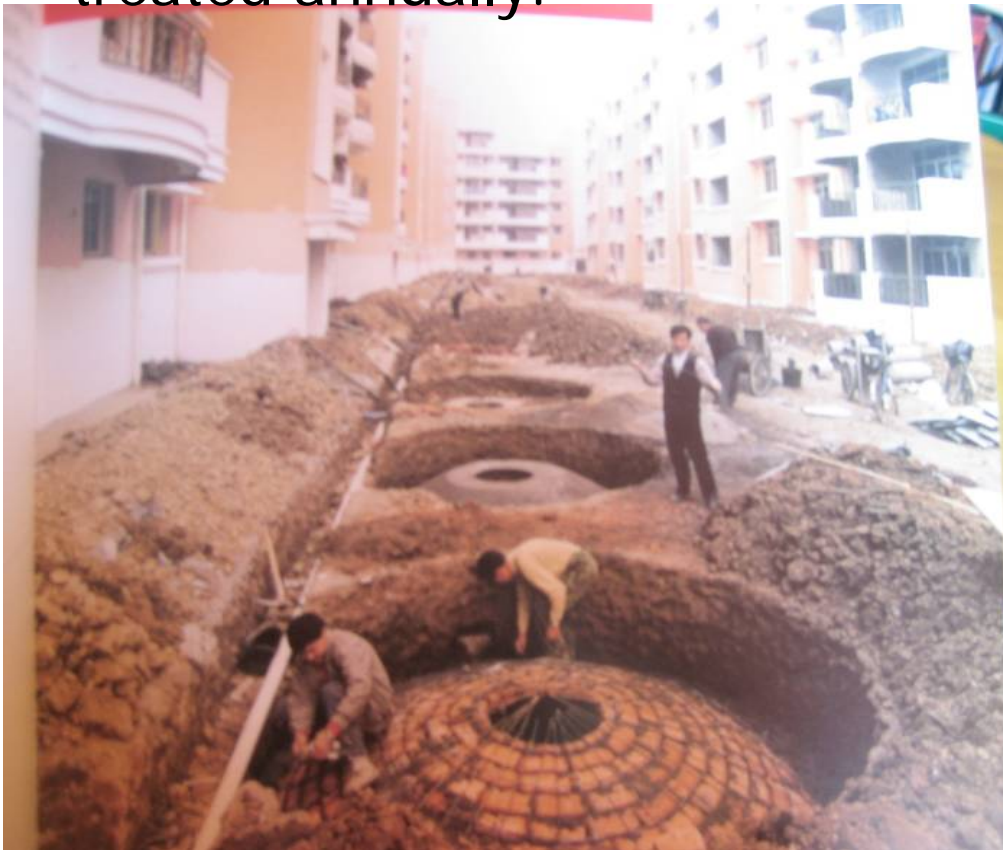

农业部能源与环境技术开发中心
Baffled septic tank
ENVIRONMENTAL PROTECTION (IEEP)
TECHNOLOGY DEVELOPMENT (CEEPTD/MOA)

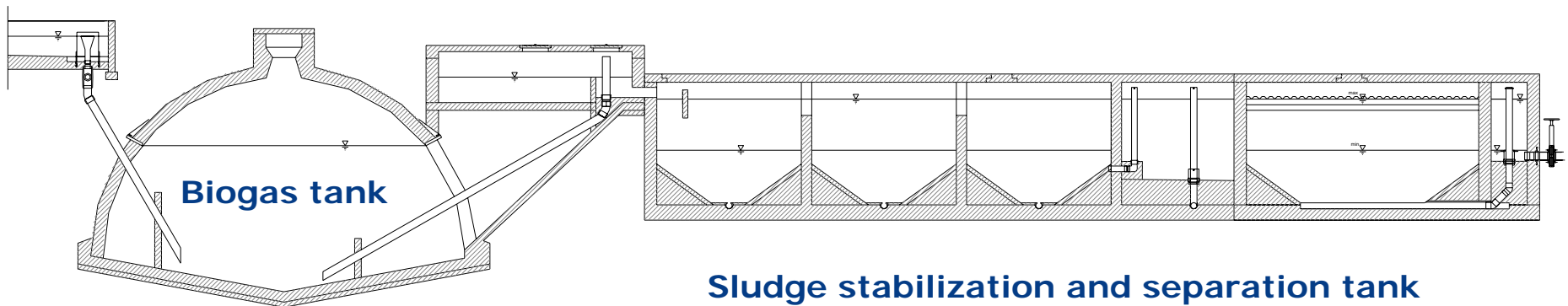
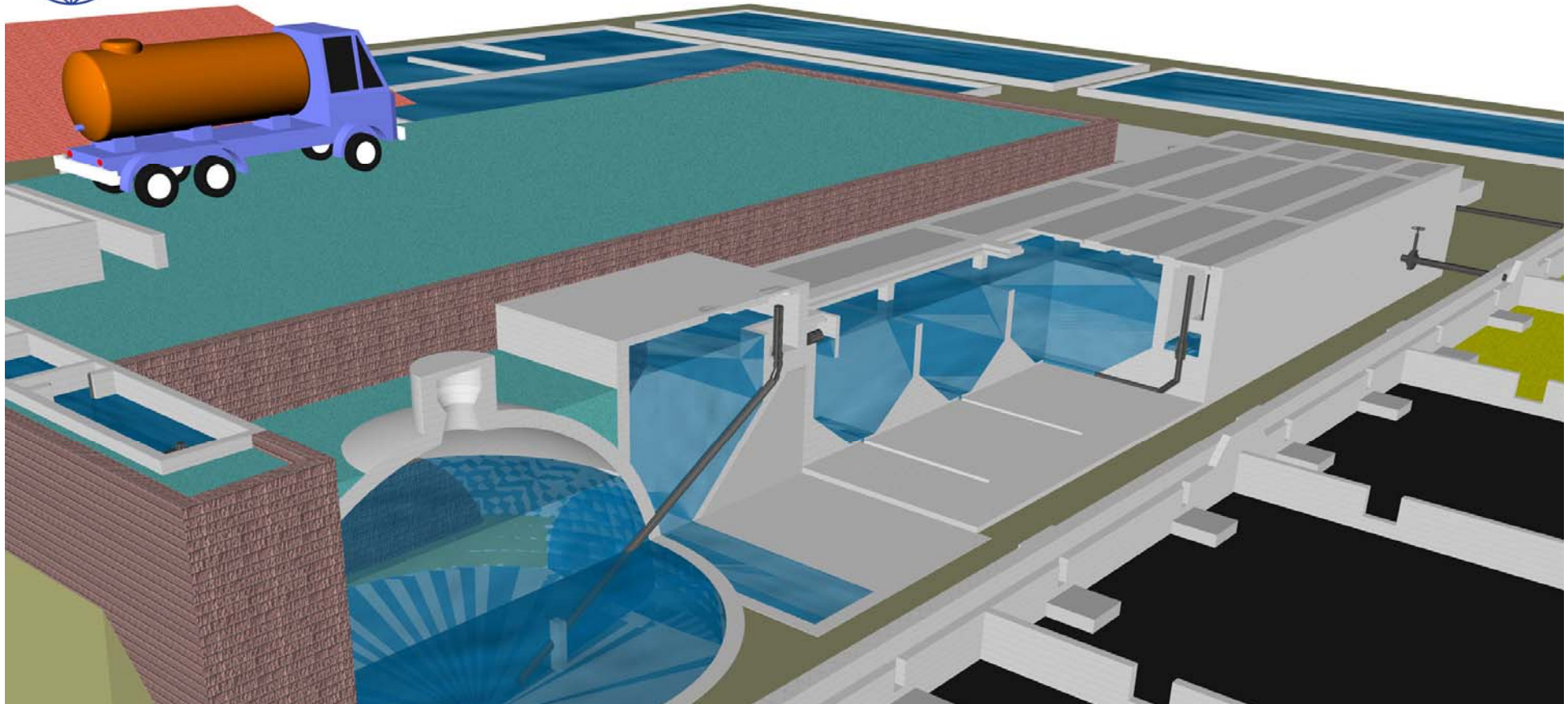

Components together

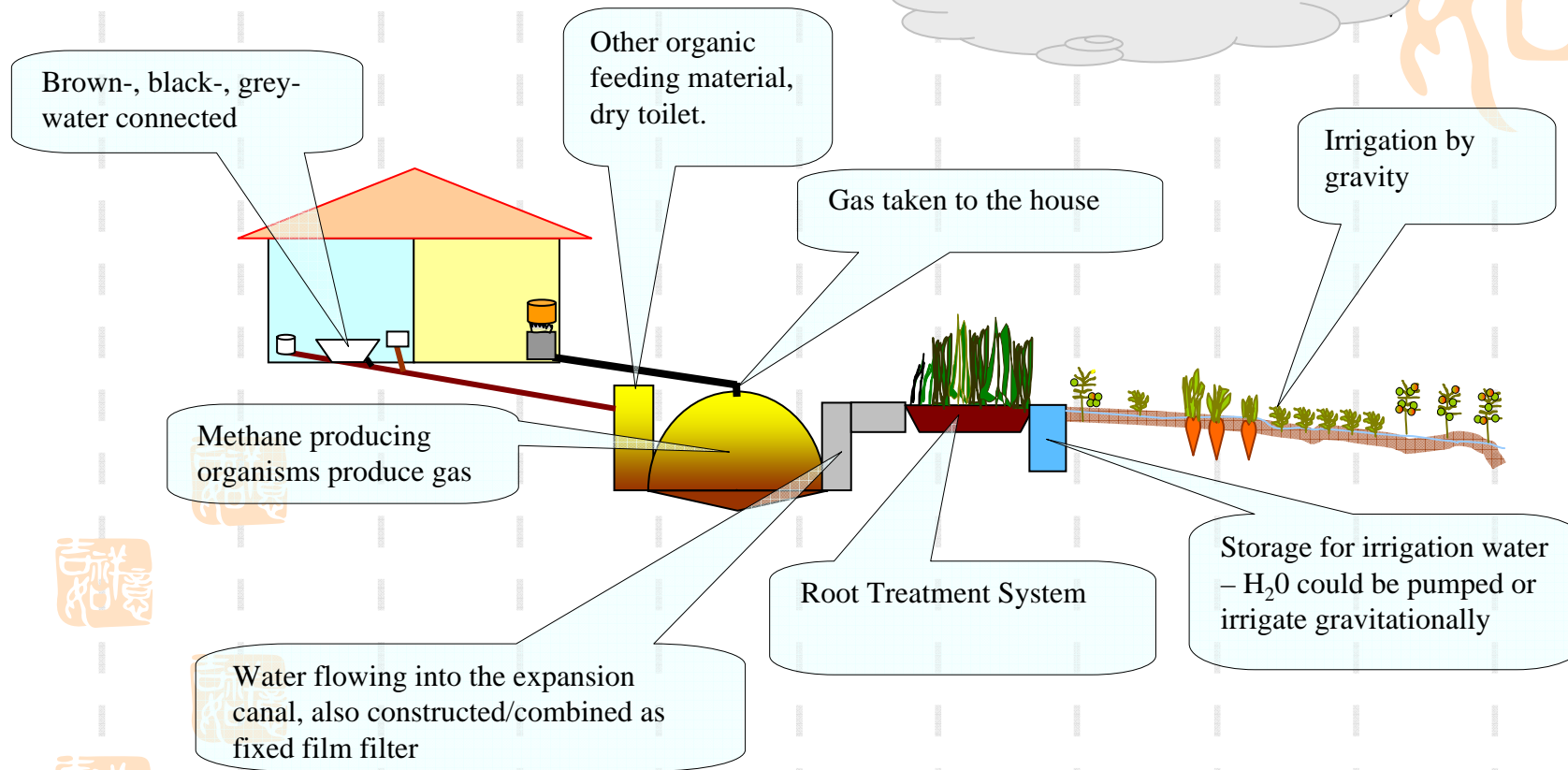

Sketch of biodigester replacing a septic tank. Wastewater as well as kitchen and garden waste enter the digester and are broken down to biogas and fertile water.

The advantages: No more emptying of septic tank. Reuse of all water in the garden. Less cost on cooking energy.



Running cost (-) or benefits (+) in Maluti per year (4 person household)

- Conventional septic tank - 600
- Biodigester septic tank +400
- Cheap pit latrine - 50
- Sophisticated double vault VIP latrines - 100
- Ecosan toilet with urine separation,
utilizing compost and urine +200
- Minimum urine separation set up,
utilizing urine only + 30

Heinz-Peter
Mang
Chinese
Academy of
Agricultural
Engineering
Beijing

