



Mainstreaming Citywide Sanitation

Opportunities & Challenges in Excreta Management

Centre for Science and Environment

Dry Sanitation System (Hygienic Toilet)

4-5 April 2016

(Project supported by: Ministry of Drinking Water & Sanitation)



Principal Investigator

Prof. K. Munshi
Director

Hygienic Rural Toilet (dry sanitation system)

Research, Design & Development
Carried out at
IDC, IIT Bombay
&
CTech Labs Pvt Ltd

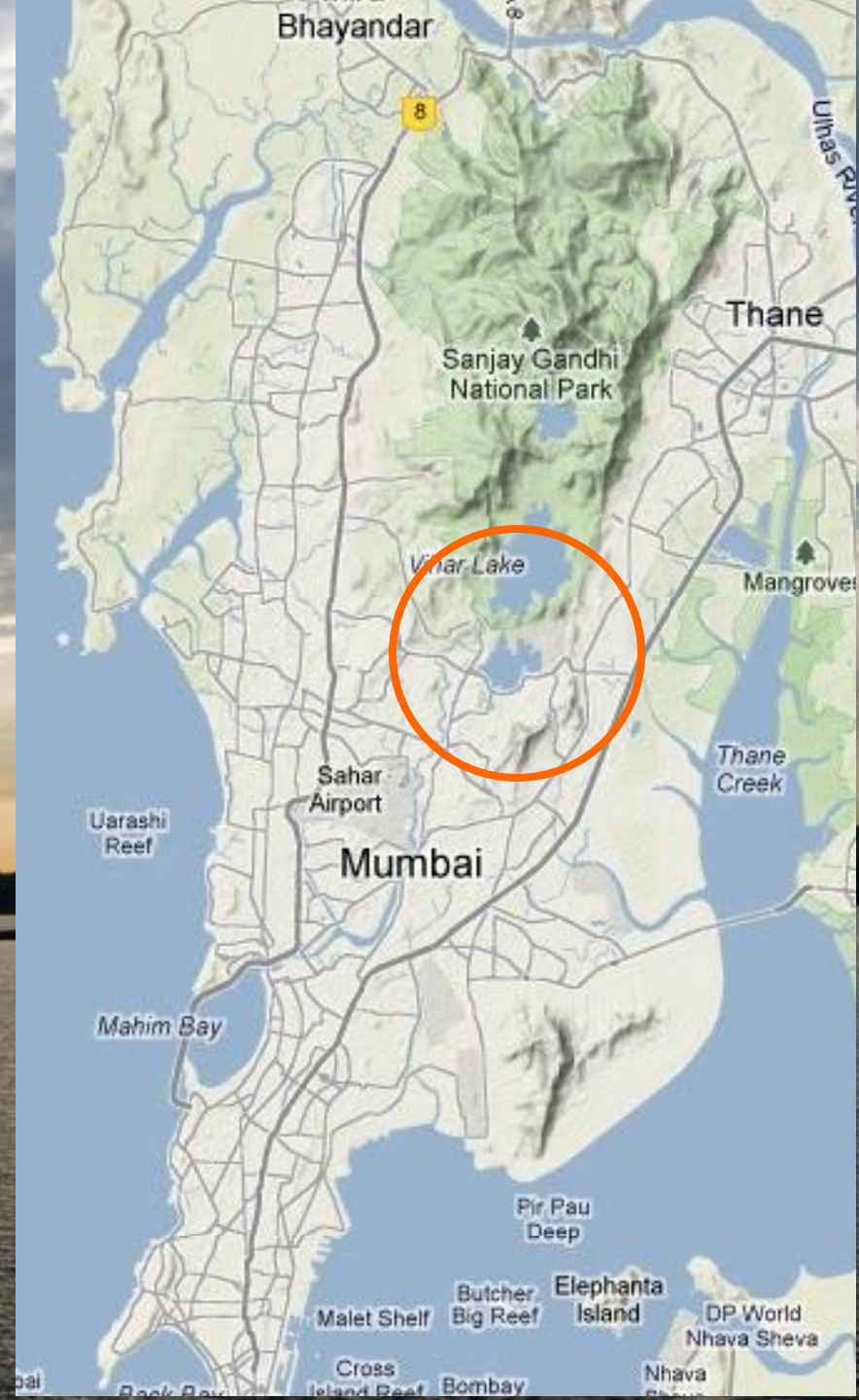

IDC

IIT Bombay

*offers a 2-year program
M Des*

Industrial Design

Visual communication

Interaction Design

Animation Design

Mobility & Vehicle Design



*The program is meant to develop
Knowledge, skill & aptitude to become
creative problem solvers and to bring about
innovation in the manufacturing and
communication industry*



Emphasis on socially relevant projects



Opportunities..... &
also Challenges.....



A Sine-IITB Company
*Innovation
Development
Company*

Design Integration

TECHNOLOGY



*DESIGN
INTEGRATION*
Technical Design
+
Humanistic Design

MARKETABILITY

Current Partnerships:

CAIR / ANURAG – DRDO
CIMFR – CSIR
R&D – TATA STEEL

INMAS / DIPAS – DRDO

IIT BOMBAY

*Innovation
Development
Company*

C TECH

A Sine IITB Company

4 M Strategy ?????

www.ctechlab.com

Methodology *Introducing Methodologies & product development strategies (analytical tools, creativity tools etc.) to achieve high certainty of success*

Mentoring *Mentoring for new product development, leading teams of developers. Hand-holding till the prototypes are made*

Monitoring *Monitoring product development process to create products for high productivity of design effort*

Motivating *Motivating & Challenging for higher levels of creativity*



DRY-SAN System

Making of a Hygienic Toilet

(Project supported by: Ministry of Drinking Water & Sanitation)

Design Challenges & Opportunities

Kindly Beware: There may some offensive pictures in the slides ahead

The crisis

Where there are no latrines people resort to defecation in the open.

-UNEP Report

665 million **Indians** practice open defecation, more than half the global total.

1,000 **children** younger than 5 years die every day in **India** from diarrhea, hepatitis- causing pathogens and other sanitation-related diseases

-the United Nations Children 's Fund



The crisis is especially acute for girls: Many drop-out of school once they reach puberty because of inadequate lavatories, depriving the country of a generation of possible leaders

- UNICEF

The toll on human health, due to unhygienic sanitation conditions is grim.



The Problem

Water (Flush) latrines and sewerage systems

- needs huge infrastructure
- have high maintenance costs
- cannot ensure a clean environment.
- **greater risk to public health and environment in case of failures.**



GOOD WATER → **BAD WATER**

The Possibility

Water – valuable resource

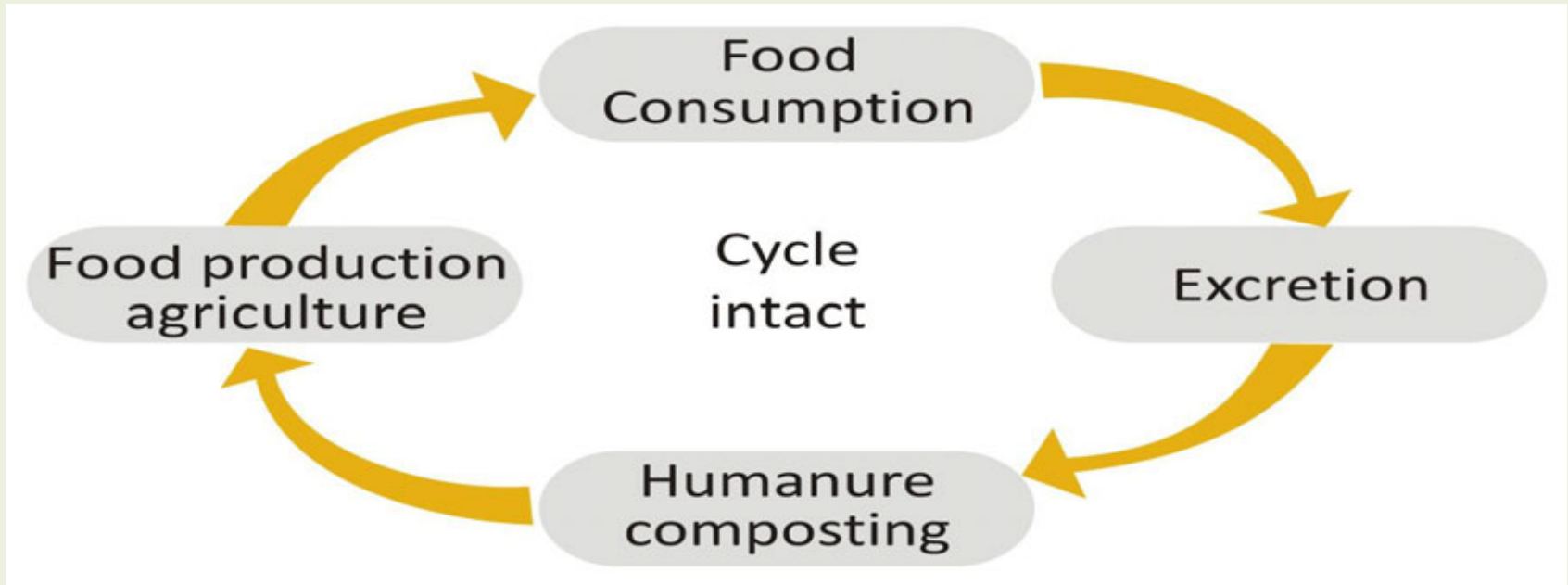

Human nutrient cycle

Utilization of composted human feces and urine (separated from feces) as organic fertilizers completes the human nutrient cycle by enriching the farming soil with nutrients.

Water less & Zero Discharge

Benefits of using hygienic dry sanitation system

- **Eliminates the spread of diseases** by treating excreta and other waste, converting this waste into a valuable resource; and avoiding contamination of water and food.
- Composted human excreta and urine could be **utilized as organic fertilizers** which completes the human nutrient cycle by enriching the farming soil with nutrients. Also eliminates or reduces the need to buy industrial fertilizers.
- **Avoids Contamination** of scarce water resources.
- Helps **save water for other purposes** - drinking, washing, cleaning etc.

The Objective

The primary goal to design **hygienic dry sanitation system** (which avoids direct discharge of excreta into the nearby water bodies or on to the open lands). To come up with a sanitation solution catering specifically to the needs of **rural India** with **water shortages** which is **cost effective, manageable, modular**, (i.e. portability, flexibility, ease of manufacturing, deployment and maintenance) and **sustainable** (derive economic benefit by making fertiliser for their fields)

*Pilot Installation of the proposed toilet units at the key rural sites will **create awareness** among the people at these sites as well as neighboring communities about benefits of using the dry toilet. They will **get habitual** to toilet usage when it becomes a part of their daily necessities. **Feedback from these users** will be valuable **for further refinements in the design.***

The methodology

Design Research and analysis

Literature review

Field study

Data collection & documentation

Data analysis

Concept Generation and evaluation

Design concepts & selection

Virtual modeling / physical modeling trials

Design Integration and development

Design development

System Integration

Design Evaluation

Working model /Prototype building for lab trial

Field trial, validation

Design Implementation, Deployment and Maintenance

Current Indian scenario

Public toilets available in **near rural & semi-urban** areas are not maintained properly and thus unhygienic to use.

- Cracked toilet pans
- Broken tiles
- Broken doors
- Accumulation of dirt at corners, joinery
- Difficult to maintain for public use

Resulting in very short work life and disuse



Village Uttanpada



Contractor Labour colony toilet, IITB



Village Sai Bangoda



Indiranagar village??

Current Indian scenario

Remote rural areas do not have access to or affordance for ceramic tiles and ceramic WCs. Local material is used for shelters.

Dry Toilet is therefore norm.

These are in fact good aspects.

But they **lack the technology for disposal and decomposition**

So the **conditions are unhygienic.**

- Inexpensive
- Exposed and dripping fecal matter and urine - unhygienic
- Difficult to maintain
- Cleaning not possible



Uttarakhand



Assam



Himachal



Ladakh

Behind the Toilet Facades

BMC spend
Rs.3 Lakhs per
toilet seat in
Mumbai slums, if it
is to be connected
to sewage system



**Need for
Zero
Discharge
Toilet**



The Design brief

The hygienic dry sanitation system with arrangement for separation of **Solid Waste, Urine & Washing Water**

- Squat type **toilet pan with three exclusive ports** for solids, urine and washing water
--- comfortable, cleanable, unbreakable
- **Arrangement of pits** below it for collection of solids, urine and washing water
--- for decomposition & utilization as manure
- **Shelter** for housing the toilet pan
--- for privacy

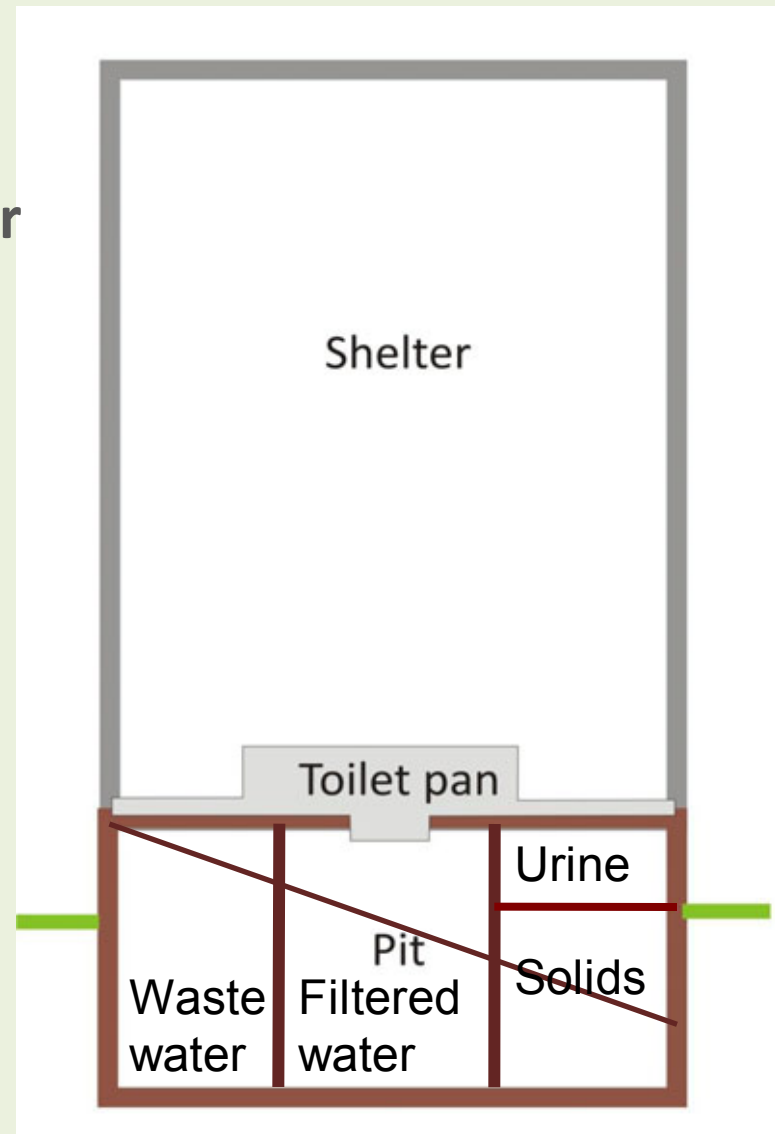

Ergonomic research

- The Indian squatting position for defecation was simulated with various users to get the suitable dimensions for the toilet pan.
- Tape drawing of the plan view was done to define the position for defecation.
- The parameters for the comfortable position were measured and noted down.
- Users were asked to sit comfortably in a squatted position and their opinions recorded to confirm the above to confirm the above.

The figure shows the basic rig used for measurements for user position. The center of the pit for defecation was taken as the center with X and Y axis defined as shown.

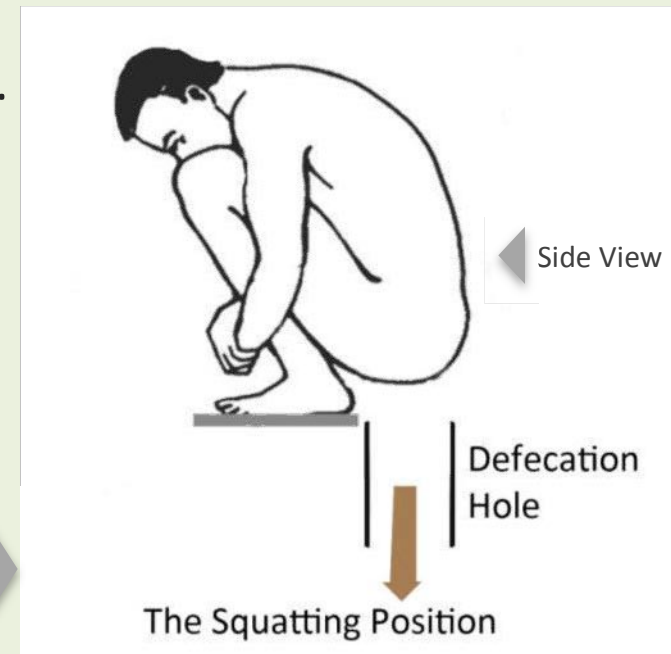
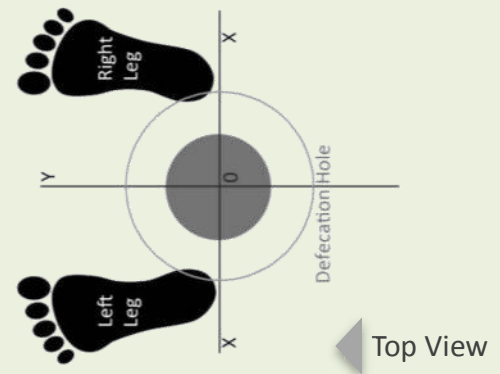

Ergonomic Design - Toilet Pan



Squatting user



Tape drawing on the ground

**Based on
Anthropometric studies**



Determination of cabin size

Toilet Pan – Engineering Design

Unique pan design with 3 ports

1. Front compartment for urine collection and drainage
2. Centre large hole for defecation
3. Washing water collection & Drainage

Front compartment for urine collection and drainage

Washing water collection & Drainage

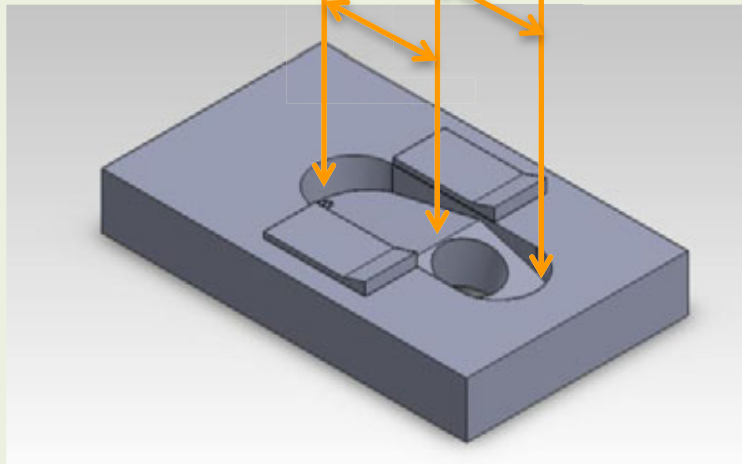

Digital Model Snap Shots

Inclination at heel aids in easy getting up from squatting position -Helpful for the elderly

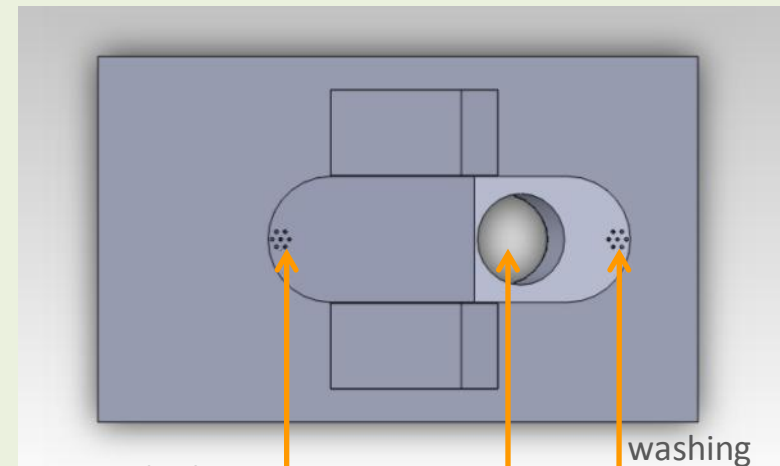

Urine discharge port

washing water port

Solids discharge port

Toilet Pan Design

OPTIMISED
DIMENSIONS

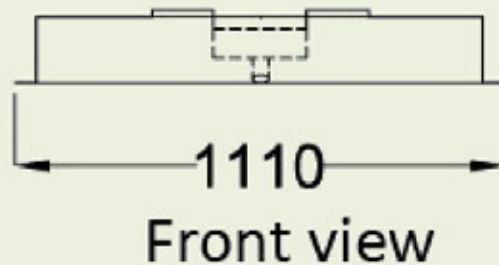
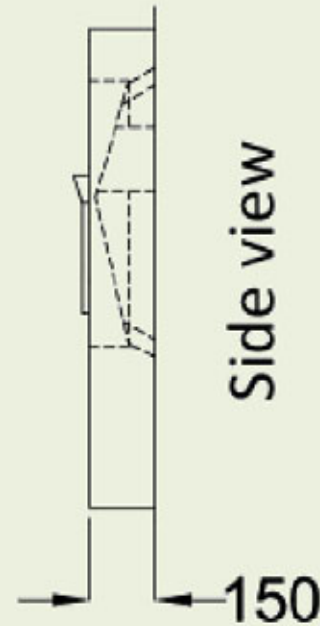
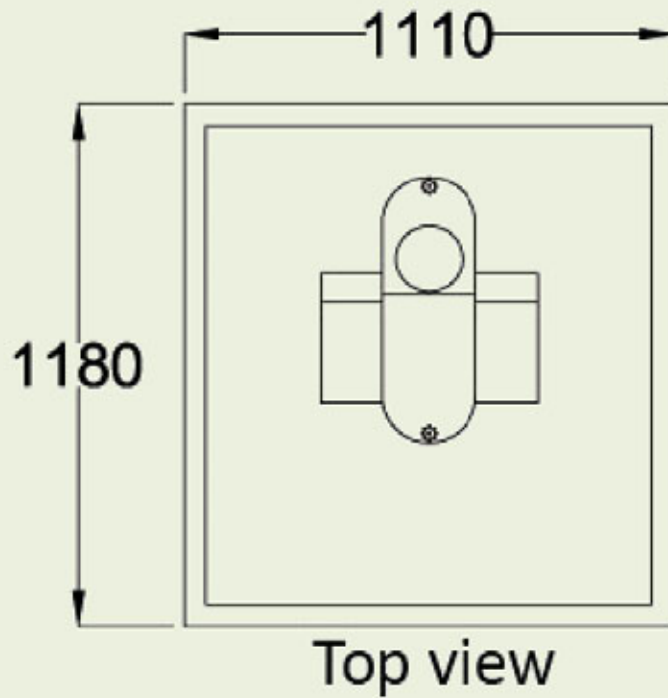

Toilet Pan - Design highlights

- **Separation of washing water** at the source with exclusive port in the pan at the back.
- **Separate urine collection** port in the front
- **Unique heel support** aids in getting up from squat position, **especially for elderly.**
- **Stainless Steel pan** is **durable, unbreakable** and can last more than 20 years – **long useful life**
- Cleaning and maintaining the pan is easier as SS **resists chemicals** and removes accumulated dirt easily.
- Can be **scrubbed** if required.

Features to be added in pan design

- **Self closing hinged flap** for fecal discharge port to keep it closed when not in use
- **Built in bidet** arrangement for anal cleaning.



Dry Toilet - Pit Design

- The solid waste pit consists of a stepped depression in the ground lined with bricks / cement blocks as shown in the figure
- The bamboo mat is placed at an angle so as to ensure rolling of the solid waste to the far end.
- Bamboo mat is being used as a sieve to filter the washing water from solid waste
- The washing water seeps through the mat and gets collected in the deeper part of the pit.
- Waste water will eventually drain into the ground after getting filtered through sand, lime and gravel bed
- Solid waste disintegrates through self generated bacterial action and converts into manure.

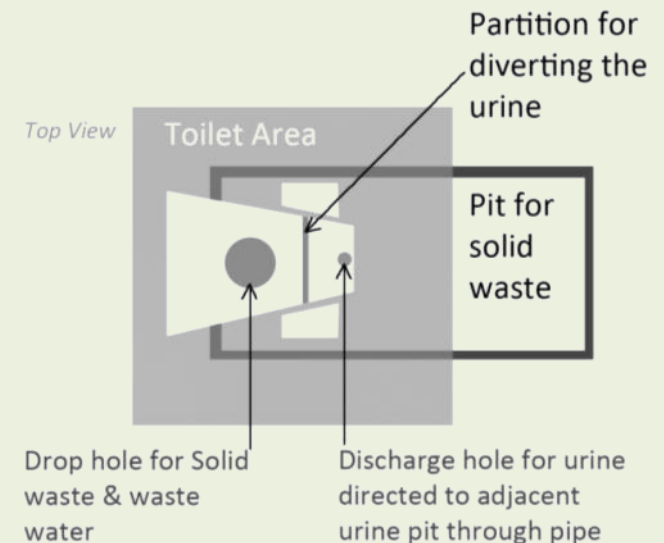
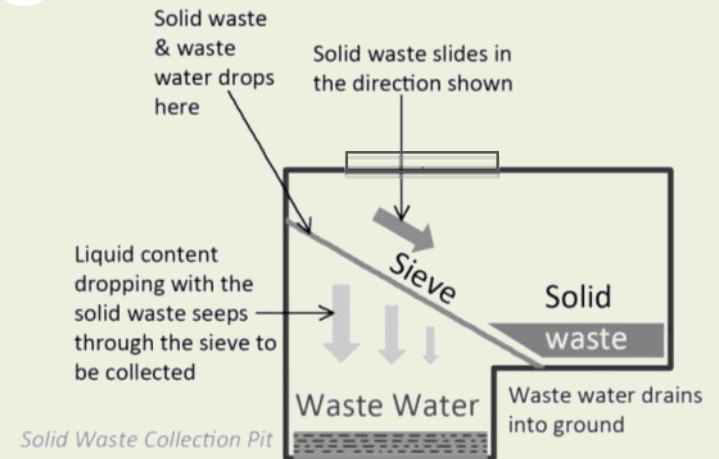

Schematic diagram of the pit

Pit configurations- explorations

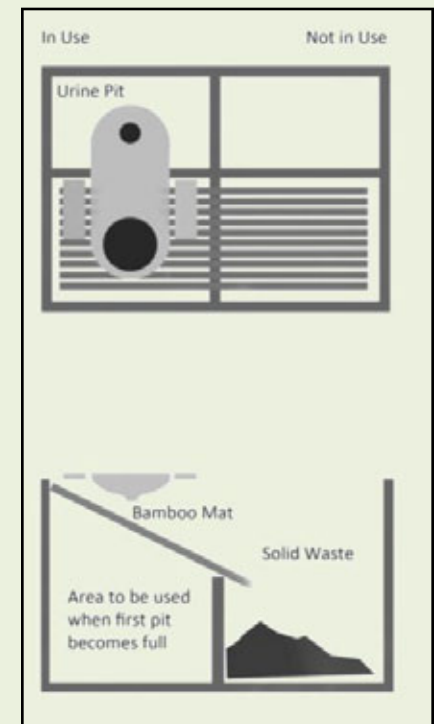
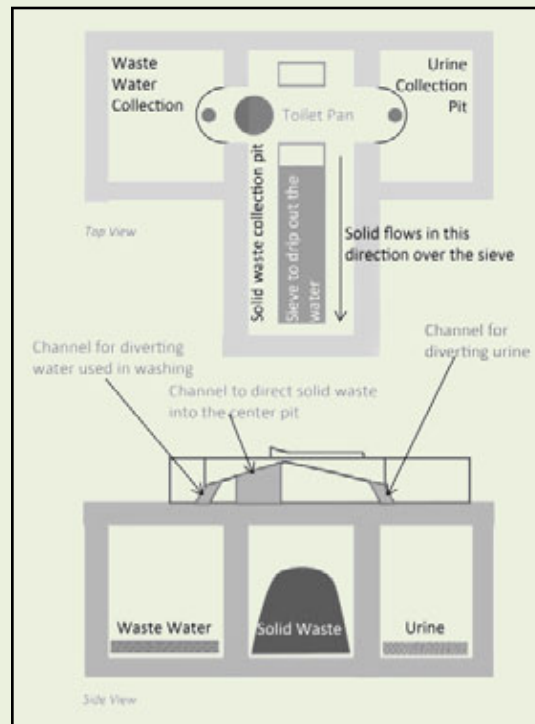
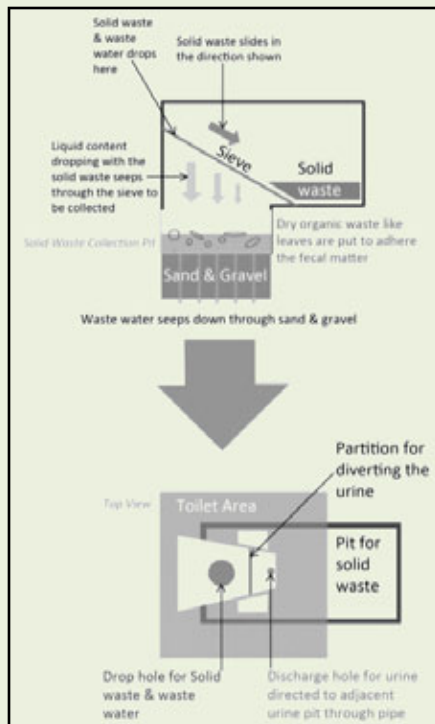

- Challenges:**
- Waterless – No flush system
 - No use any chemicals, enzymes – No external additives
 - Aid & accelerate natural process of decomposition
 - Women friendly – help in disposing sanitation pads
 - Elderly friendly
 - Bring science to empirical level – easy understanding (No mystery)

Digital Models of Pit Design

- The design consisted of 3 chamber pits
- One chamber each for: waste water, solid waste and urine.
- There are 3 separate discharge point in the toilet pan.
- The front port is for urine.
- The middle port which is largest in size is for solid waste.
- The rear port is for waste water utilized in cleaning.

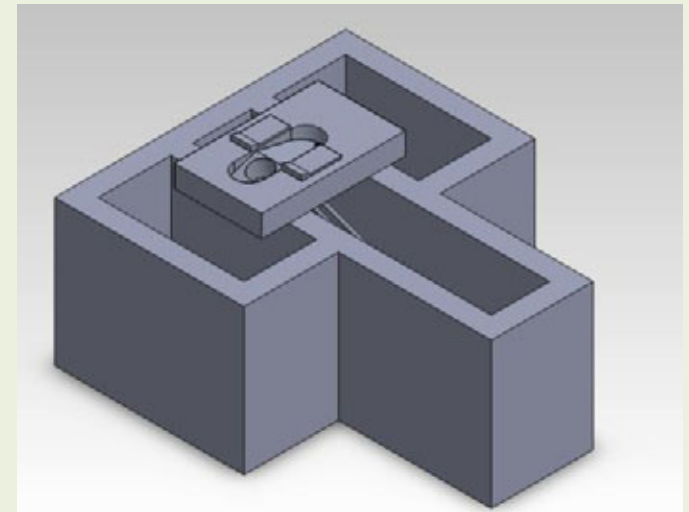
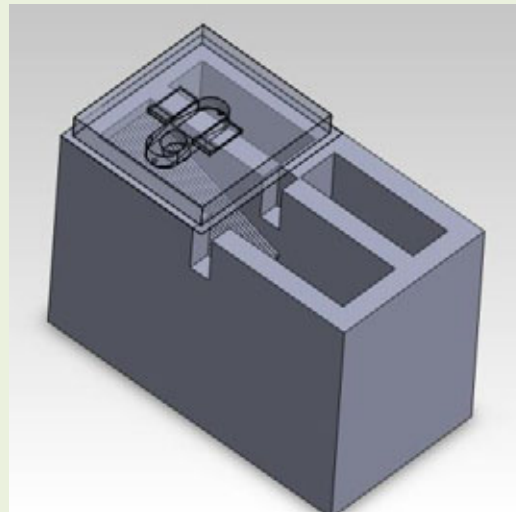
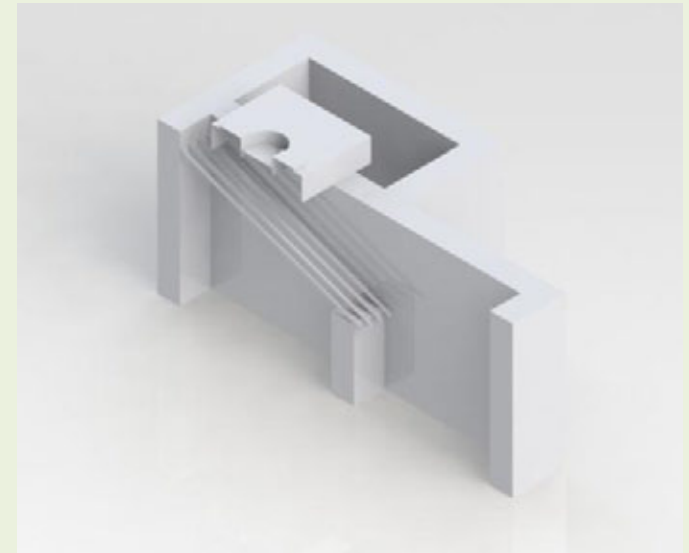

Prototype 1

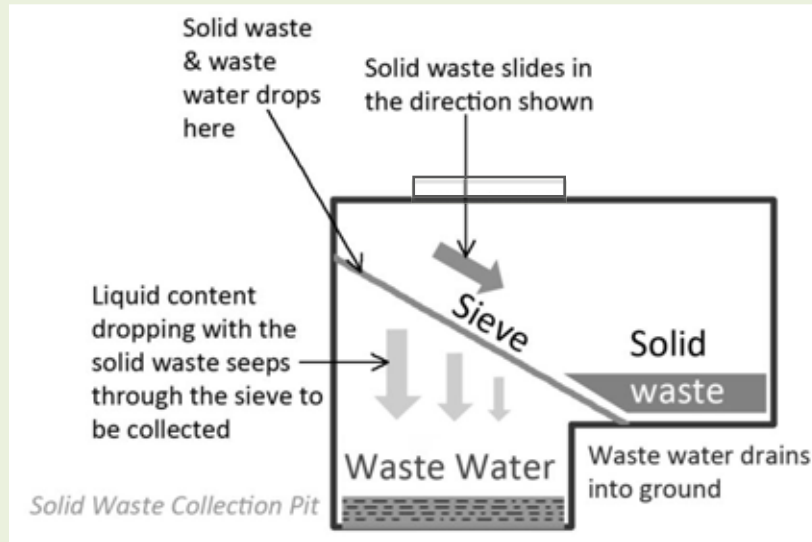

Schematic section of solids pit,
There is separate pit for urine collection



Prototype 1 - in usage



Pits under construction

Prototype 1 – Observations

After 6 months of usage (Jun 2012-Dec 2012)



Solids were found in advanced stages of decomposition acquiring a black colour, having minimal amount of odour. The solids disposed could have been further composted to make it suitable to be used as organic fertilizer.

- Solids pit (approx. 600x700x600 mm) **was not full even after 6 months**. It was being used by 30 users (only females and children) daily.
- There was inadequate drying of the solid waste in the pit specifically in the rainy season due to rainwater seepage into the pit. The users were using buckets of water to keep the toilet clean thereby keeping the water content in the solid waste too high for satisfactory decomposition and drying. This was taken care of in the next design iteration for making Prototype 2.
- Urine collected in the pit was soaked into the ground.



Solids disposal site

After 2 months



Solids looked like part of soil.

Prototype 1 - Observations

After next 8 months of usage (Jan 2013 – Sep 2013)



Solids pit

The pit was not full after next 8 months of usage.

Collected solids were found black in colour and dry. It was in advanced stage of decomposition.



Urine pit

Urine pit was dry. Collected urine was soaked up in the soil.

Toilet pan after a year of continuous usage by about 30 users daily, was in usable condition. Users were satisfied. The plywood panels of shelter needed replacement.

Prototype 2

Stainless Steel Pan & FRP Enclosure



Prototype 2



Pits under construction



Sieve placed in inclined position



Prototype 2 – in usage

The toilet is used by 20-25 users daily.

Prototype 2 - Observations

After 9 months of usage (Dec 2012 – Sep 2013)



Solids pit

The pit (885x550x1000mm³) was not even quarter-full after 9 months of usage.



Urine pit

Urine pit was dry. Collected urine was soaked up in the soil.

The pit was less than 1/4th full with daily usage by **20-25 users in 9 months**, It could be easily **used for 4-5 years** or even more without need for emptying. **The solids get shrunk as they decompose.** There is about 80-90 % volume reduction in the process. It could be said that the pit of this size could be utilized by a **family of 6 for more than 10 years without emptying**

Pit Design - Final

OPTIMISED CONFIGURATION 1

There are 3 different pits for collection of solids, urine and washing water

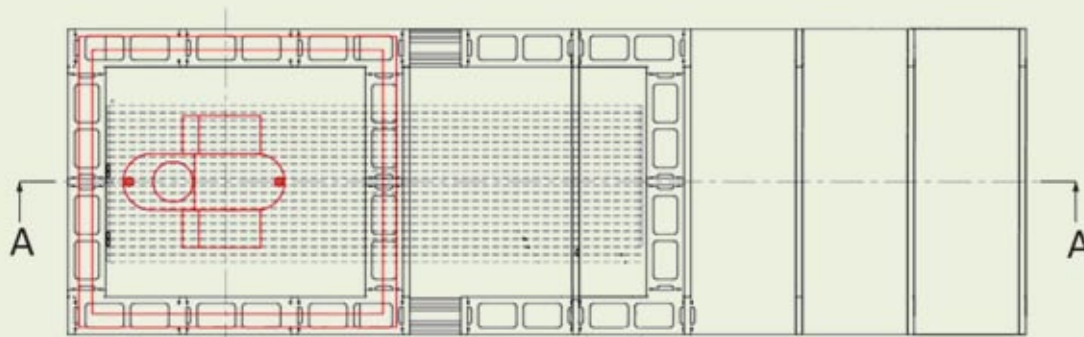

Top View

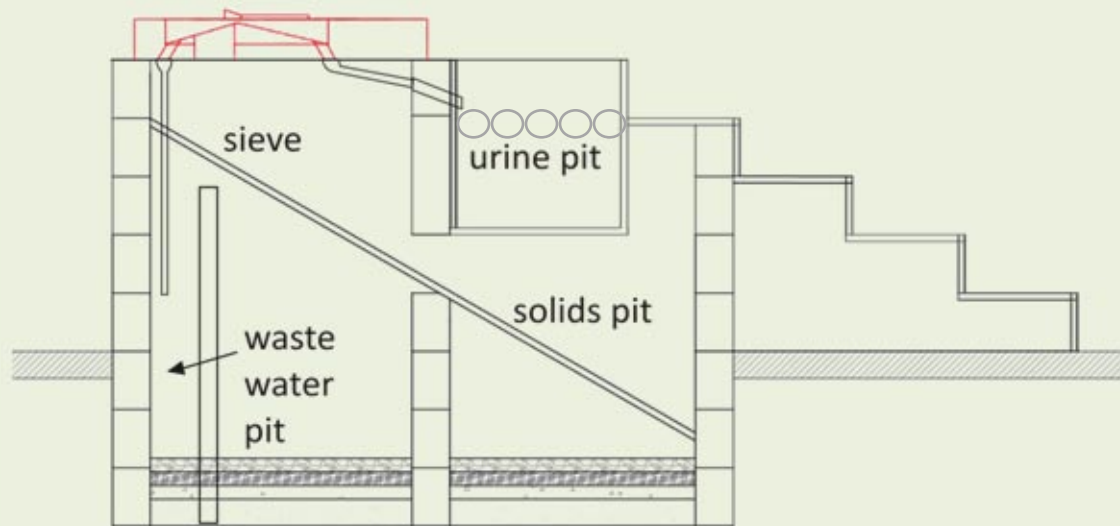

Section A-A

Pit Design - Final

DETAILED
MODELING

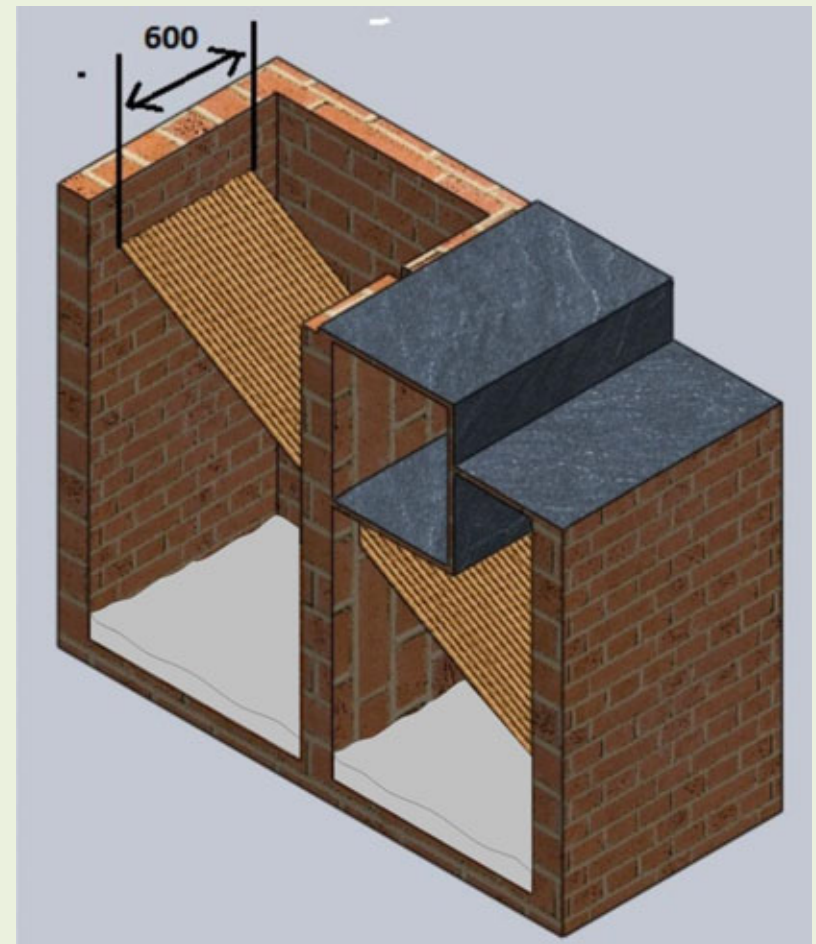
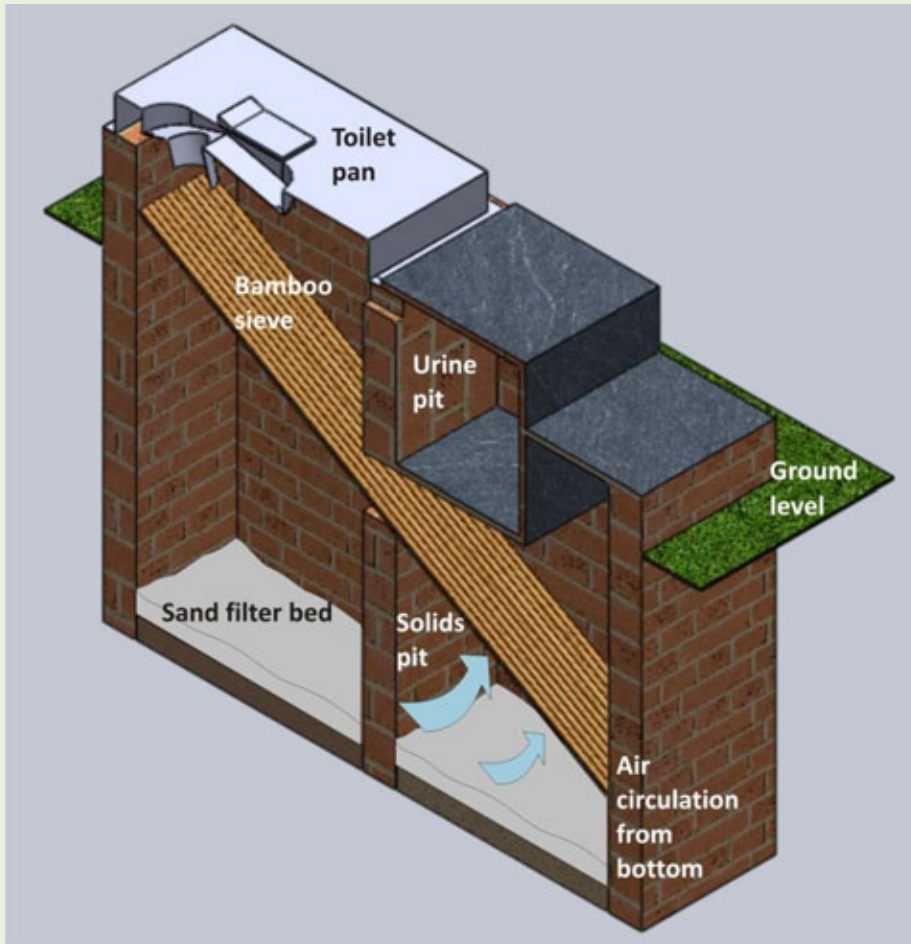

Pit Design

OPTIMISED CONFIGURATION 2

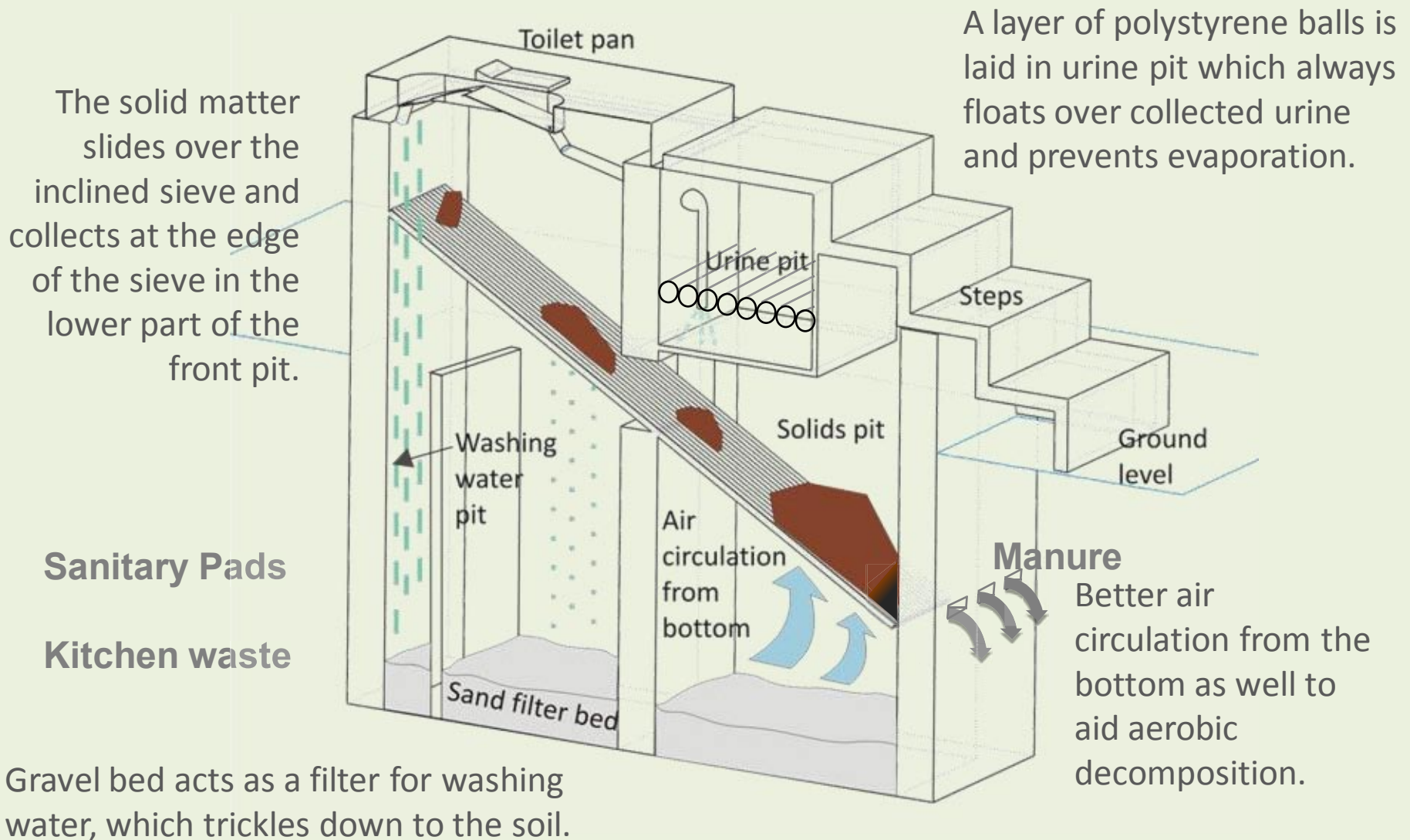

PATENT: 3711/MUM/2013 645/MUM/2014

Pit Design - Final

OPTIMISED CONFIGURATION 3

There are 3 different pits for collection of solids, urine and washing water

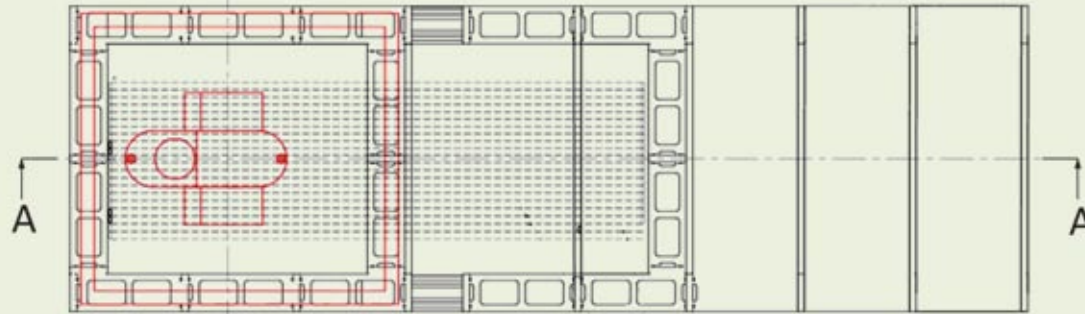

Top View

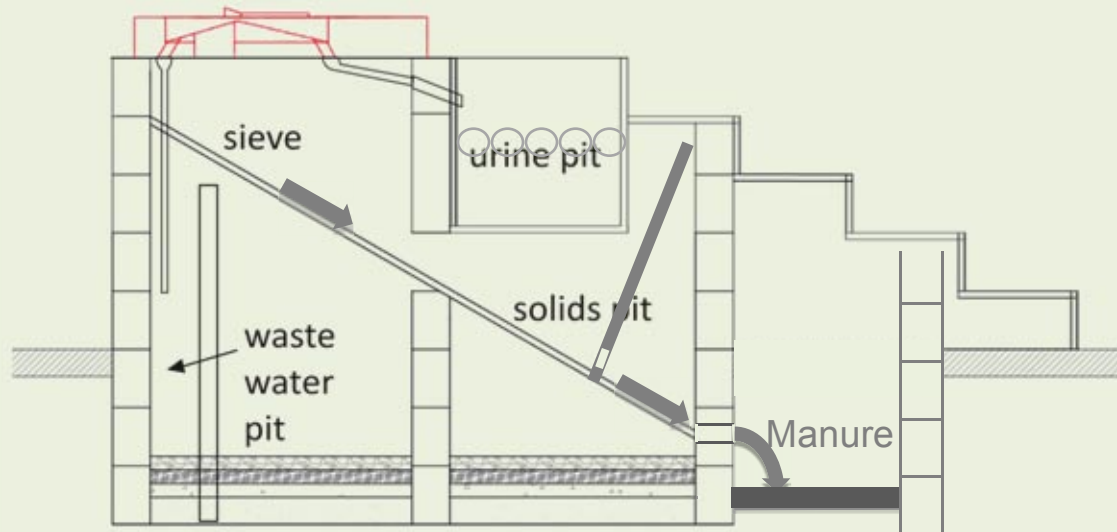

Section A-A

PATENT: 3711/MUM/2013 645/MUM/2014

Pit Design

OPTIMISED
CONFIGURATION

Pits can be

- underground
- Partially underground
- Above ground

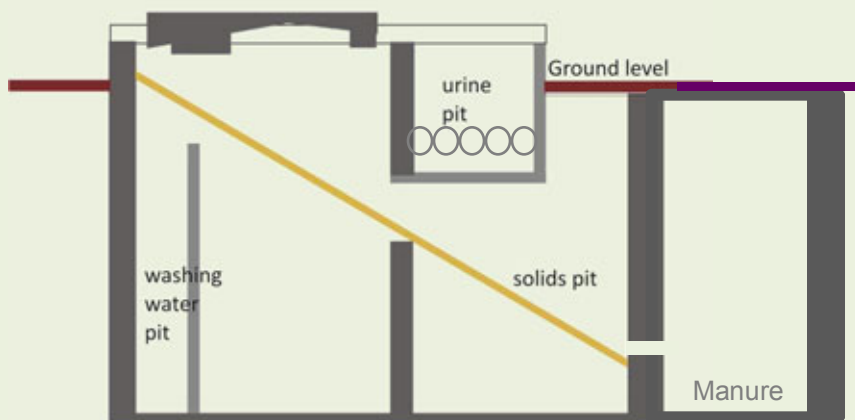

Underground pits

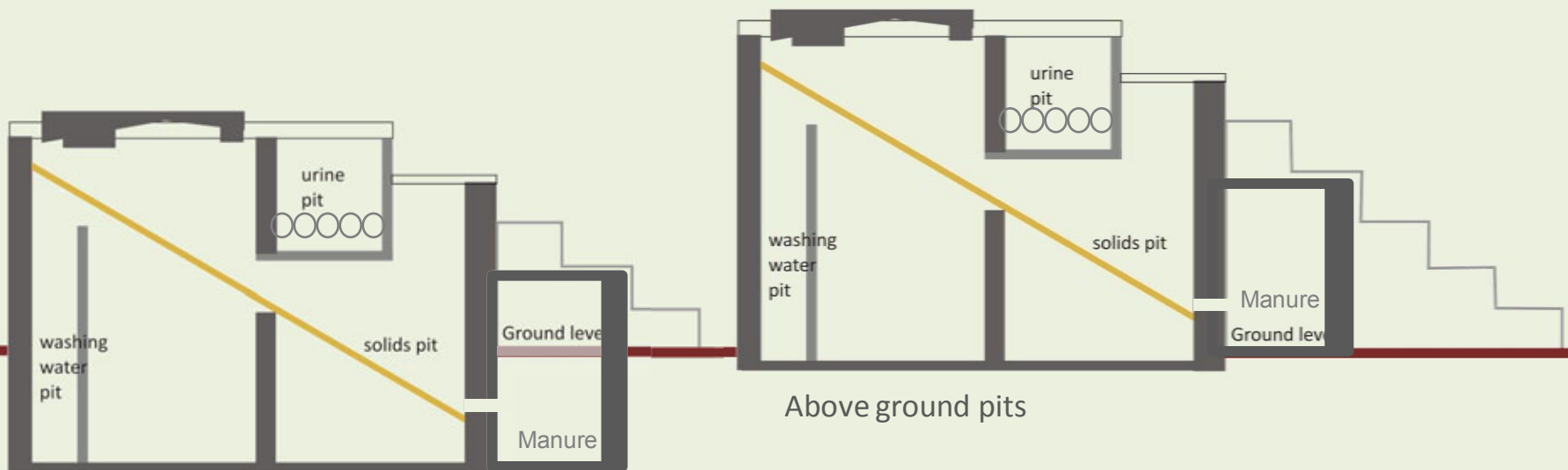

Partially underground pits

Above ground pits

PATENT: 3711/MUM/2013 645/MUM/2014

Shelter Design 1

Modular FRP panels

- Modular FRP panels are clipped together to make a shelter unit.
- Provision of built in overhead water tank (70-80 lit capacity).
- Life span could be more than 20 years.

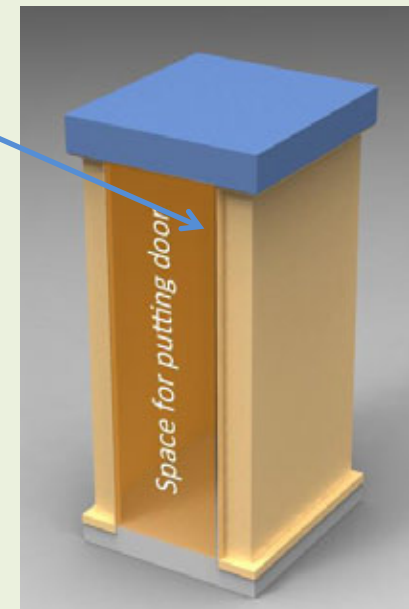
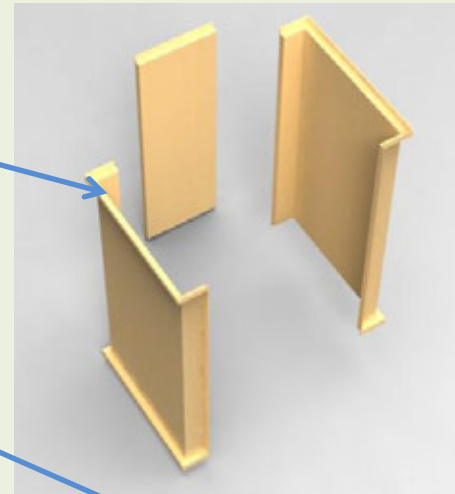

Shelter Design 2

Aluminum channel and plywood

- Basic structural framework is constructed using aluminium channels. Marine plywood is used as wall panels and roof.
- Life span can be 3-4 years for marine plywood.
- Jute phenol composite sheets could be used in place of plywood.
- Cement or Siporex boards can also be used depending on local availability and economy

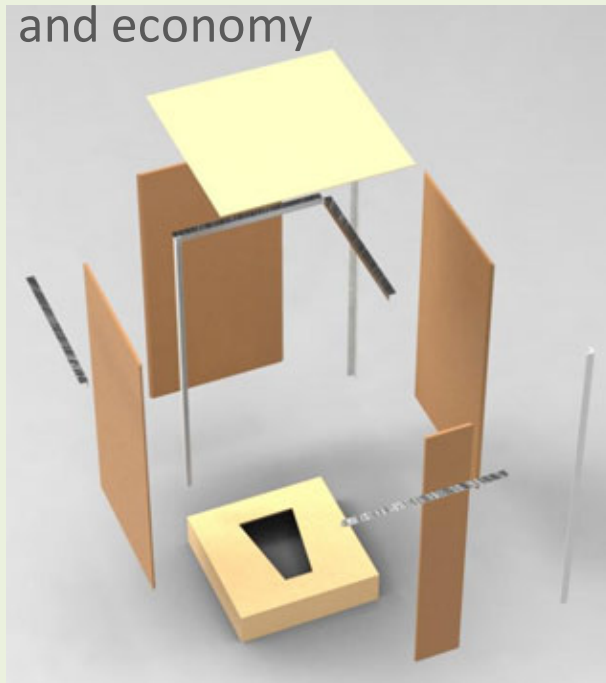

Shelter Design 3

Bamboo, jute cloth

- Structural framework using **bamboo supports** and for paneling woven **bamboo mats**, jute cloth can be used.
- Life span of such structure would be 1 season. It would need further repairs or replacement of cloth.
- A **hedge like structure** can be created using bamboo around the toilet pan and pit area.

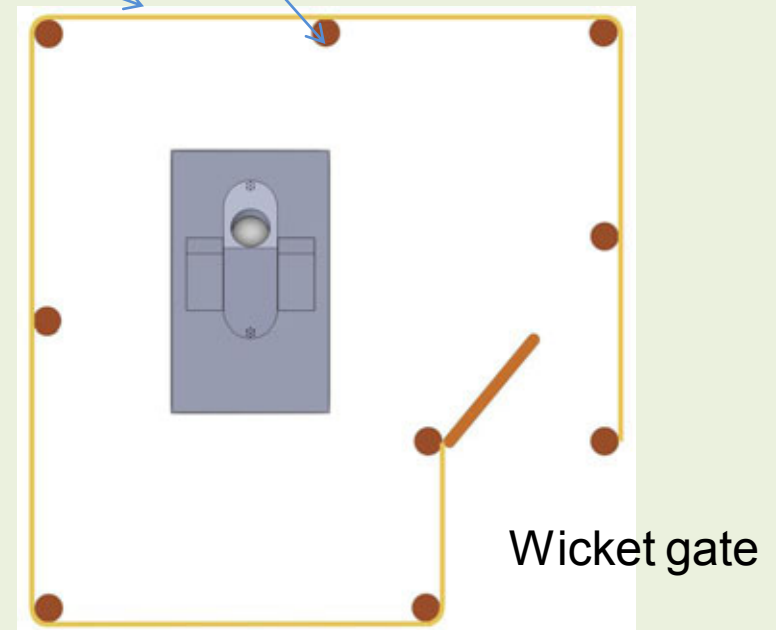
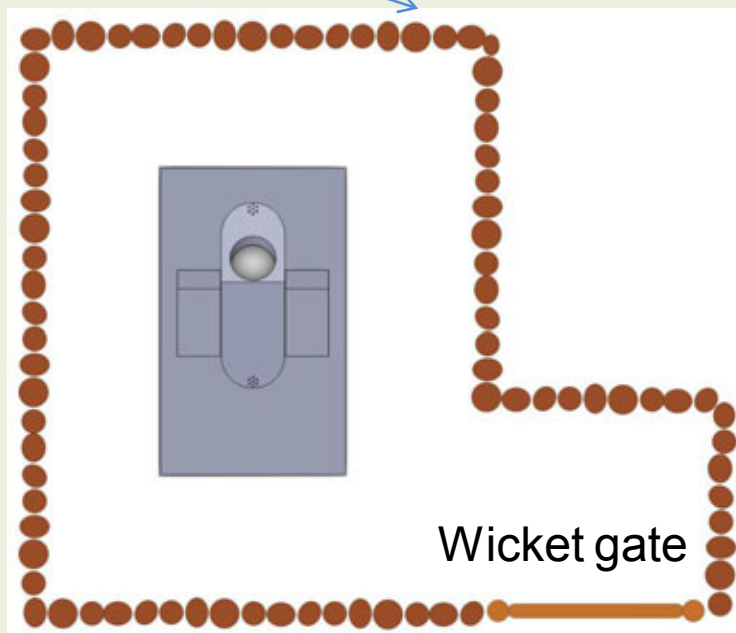

Shelter Design 4

Plants / Shrubs

- Plantation of shrubs around toilet area as shelter.
- Most simple and cost effective alternative.

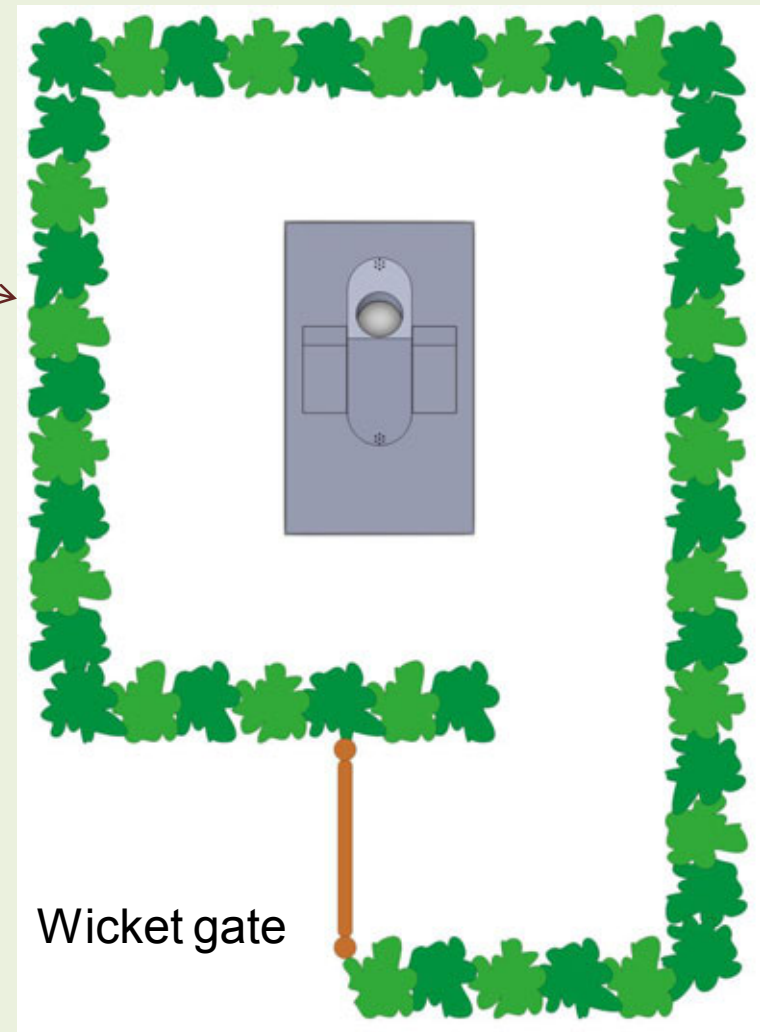
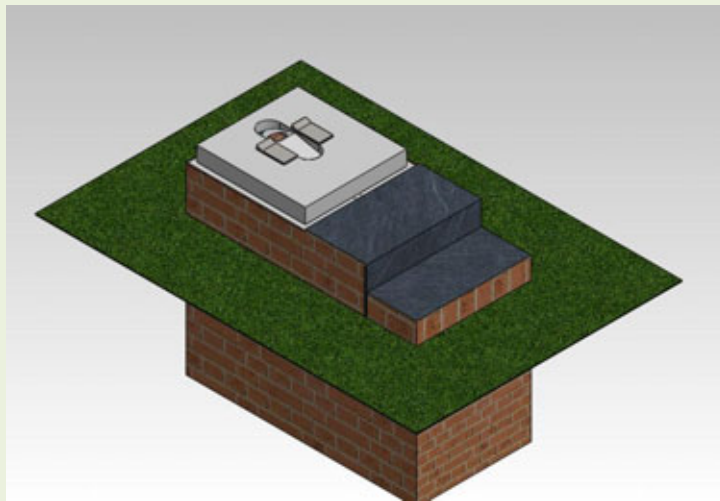

Demonstration unit



Completed pits, ready for further toilet pan assembly

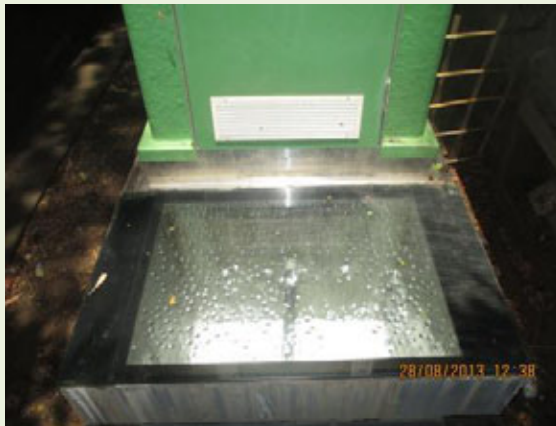

Glass window to monitor urine pit



Glass window to monitor solids pit



Vent pipe for solids pit

Demonstration unit



Demonstration unit



SS Toilet pan



Jet spray for anal cleansing



Louvers at top position of the shelter



Lighting switch for solar light



Door fixtures



Louvers at the bottom

Demonstration unit

Aim:

- Creating awareness by letting people see and use the actual product.
- Creating awareness about the possibilities of generating useful products (manure / fertiliser) from waste (fecal matter / urine).
- Opportunity to keep the toilet clean with minimum effort, thereby getting used to a clean and hygienic toilet.
- People to get habitual to toilet usage.
- People could be educated about health & hygiene through actual usage of the toilet.
- The unit can act as a demonstrator for neighborhood communities.

Social Inclusion Group of ILF&S Ltd
R&D of Tata Steel Ltd
Interested in trying it out and deployment



References

- Background Paper of the Millennium Project Task Force on Water and Sanitation, Millennium Project, April 2003. Available on the worldwide web: <http://www.unmillenniumproject.org/documents/tf07apr18.pdf>
- A guide to sanitation and hygiene for those working in developing countries, Available online at: http://www.drytoilet.org/pdf/Sanitation_Guide.pdf
- <http://www.unmillenniumproject.org/documents/WaterComplete-lowres.pdf>
- JENKINS. The Humanure Handbook. A Guide to Composting Human Manure. Grove City, USA 1999. [web document]. Available on the worldwide web: <http://www.weblife.org/humanure/default.html> [cited 15.5.2005]
- Guidelines for assessing the risk to groundwater from on-site sanitation. British Geological Survey and Robens Centre, Oxford, 2001. [web document]. Available on the worldwide web: [http://Inweb18.worldbank.org/essd/essd.nsf/GlobalView/C16_ARG.pdf/\\$File/C16_ARG.pdf](http://Inweb18.worldbank.org/essd/essd.nsf/GlobalView/C16_ARG.pdf/$File/C16_ARG.pdf) [cited 15.5.2005]
- Enwell – Water and Sanitation Project. The Finnish Red Cross.
- Ventilated Improved Pit Latrine. Construction Manual. UNICEF, Kenya.
- CONANT. Sanitation and Cleanliness for a Healthy Environment. Hesperian Foundation, Berkeley, USA, 2005. Available on the worldwide web: http://hesperian.org/pdf_files/EHB_Sanitation_EN_lowres.pdf
- (In Finnish). MALKKI. Kompostikäymäläopas. Työteho-seura, 1995. ISBN 951-788-221-1.
- (In Finnish). PAATERO, LEHTOKARI, KEMPPAINEN. Kompostointi. WSOY, Juva, 1984. ISBN 951-0-12502-4
- SCHÖNNING, STENSTRÖM. Guidelines for the Safe Use of Urine and Faeces in Ecological Sanitation Systems. EcoSanRes, Stockholm, 2004. ISBN 91-88714-93-4
- Introducing urine separation in Switzerland: NOVAQUATIS, 2nd international symposium on ecological sanitation, April 2003
- Water on Tap Improves Rural Quality of Life. (2009, September). Retrieved December 24, 2011, from IDA at work: <http://web.worldbank.org/WBSITE/EXTERNAL/EXTABOUTUS/IDA/0,,contentMDK:22311356~menuPK:4754051~pagePK:51236175~piPK:437394~theSitePK:73154,00.html>
- Chakraborty, P. (2008, November 4). Leach Pit Toilets for Rocky terrain- Experiences and Examples. Retrieved December 28, 2011, from Indian Sanitation Portal:
- Basic Principles of Composting available online at: <http://www.lsuagcenter.com/nr/rdonlyres/1a247d4f-4e94-4021-b09e-2df1043e179e/2908/pub2622compost.pdf>

Costing in Rupees

	Demo unit	Batch	Mass	per year
SS Toilet pan (20 year life)	17-20 K	10-12K	4-5K	250/-
Pit Construction (20 year life)	10 K (Bricks)	10K	4-6K	150/-
	20-25 K (Labor)	5-7 K	5-7 K	350/-*
	(Mumbai prices)			<u>750/-</u>
Shelter-FRP (20 year life)	45-50 K	30-32 K	25 K	1250/-*
Super structure (Bamboo)	---	?	?	
Super structure (Steel / Plywood / Jute / mud)		?	?	
Revenue from manure produced	-	-	?	(?)

* Scope of cost reduction in certain situations

Cost / person / day = Rs. 750 / 6 / 365 = Rs. 0.35 p
Cost / person / day = Rs. 750 / 30 / 365 = Rs. 0.07 p

Hygienic Rural Toilet (dry sanitation system)

The Dry-San toilet is a hygienic dry sanitation system which avoids direct discharge of excreta into the nearby water bodies or on to the open lands. It is a sanitation solution catering specifically to the needs of rural India with water shortages, which is cost effective, manageable, modular, (i.e. portable, flexible, easy to manufacture, deploy and maintain) and sustainable (derive economic benefit by making fertilizer for their fields)

2012 - 2014



Waterless – No flush system

No chemicals, enzymes – No external additives

Aids & accelerates natural process of decomposition

Women friendly – help in disposing sanitation pads

Elderly friendly

Utilisation of waste as fertiliser

Bring science to empirical level – easy understanding

(No mystery)

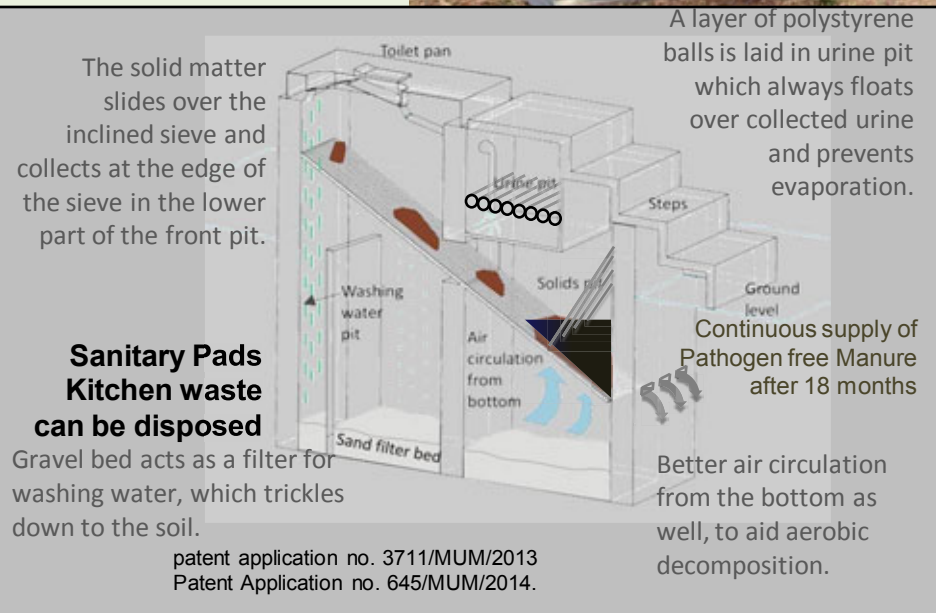

Alternate Pit Designs

BRICK & MORTAR PIT

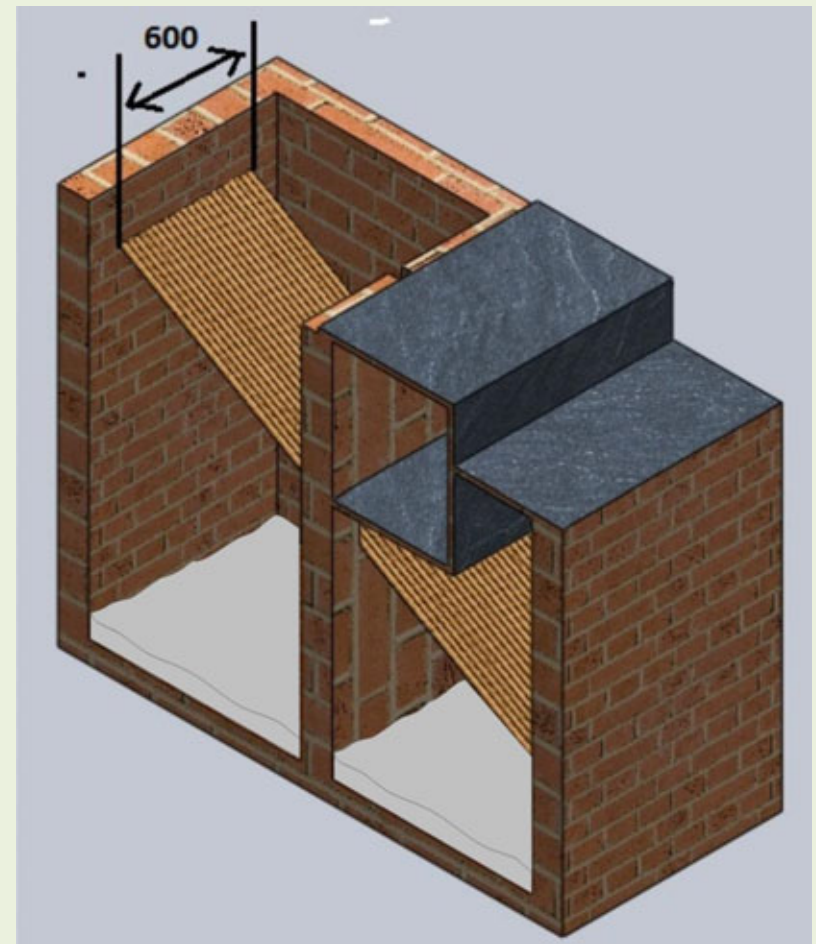
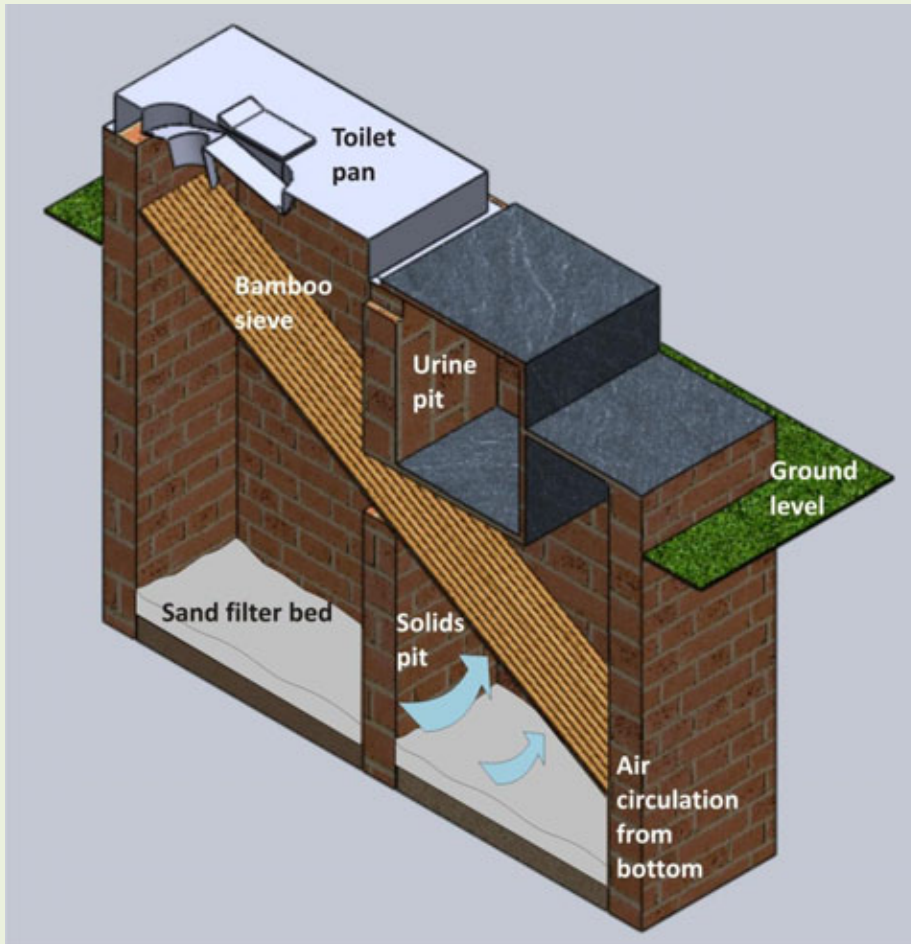

Alternate Pit Designs

ROTOMOLDED
SINGLE PIT

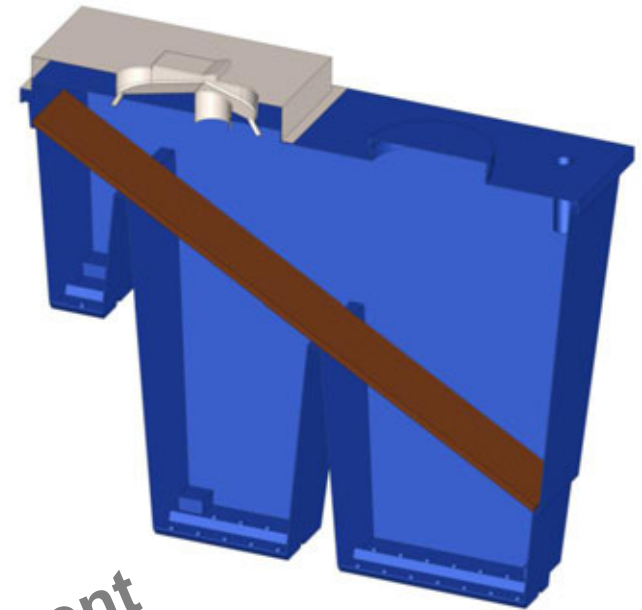

Under Development

Alternate Pit Designs

ROTOMOLDED
TWIN PIT



Under Development

Alternate Pit Designs

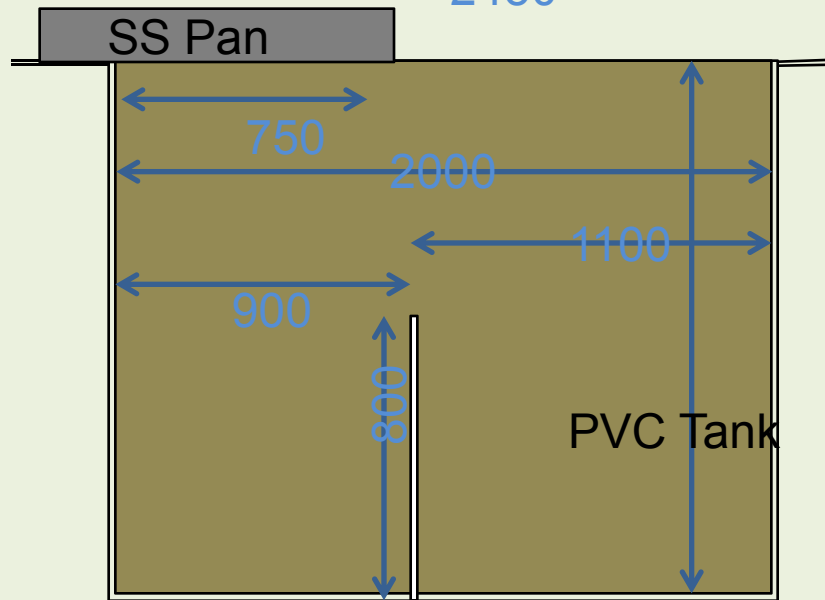
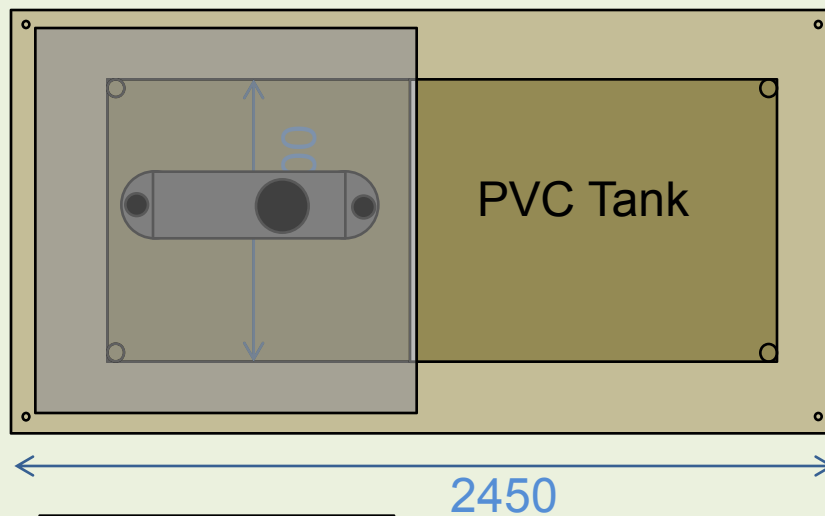

FLEXIBLE BAG PIT

FABRICATED PIT

Under Development

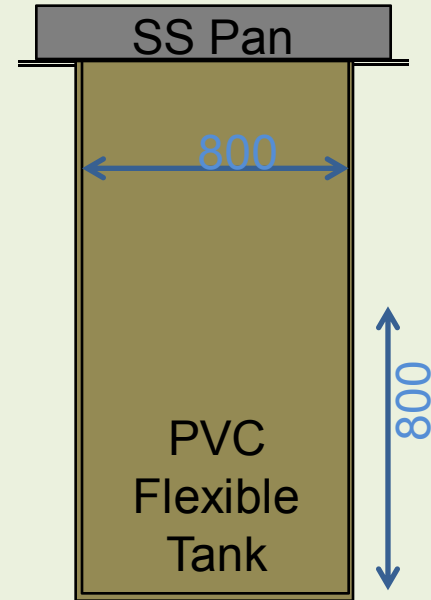

Designs for Multi-storey

Under Development

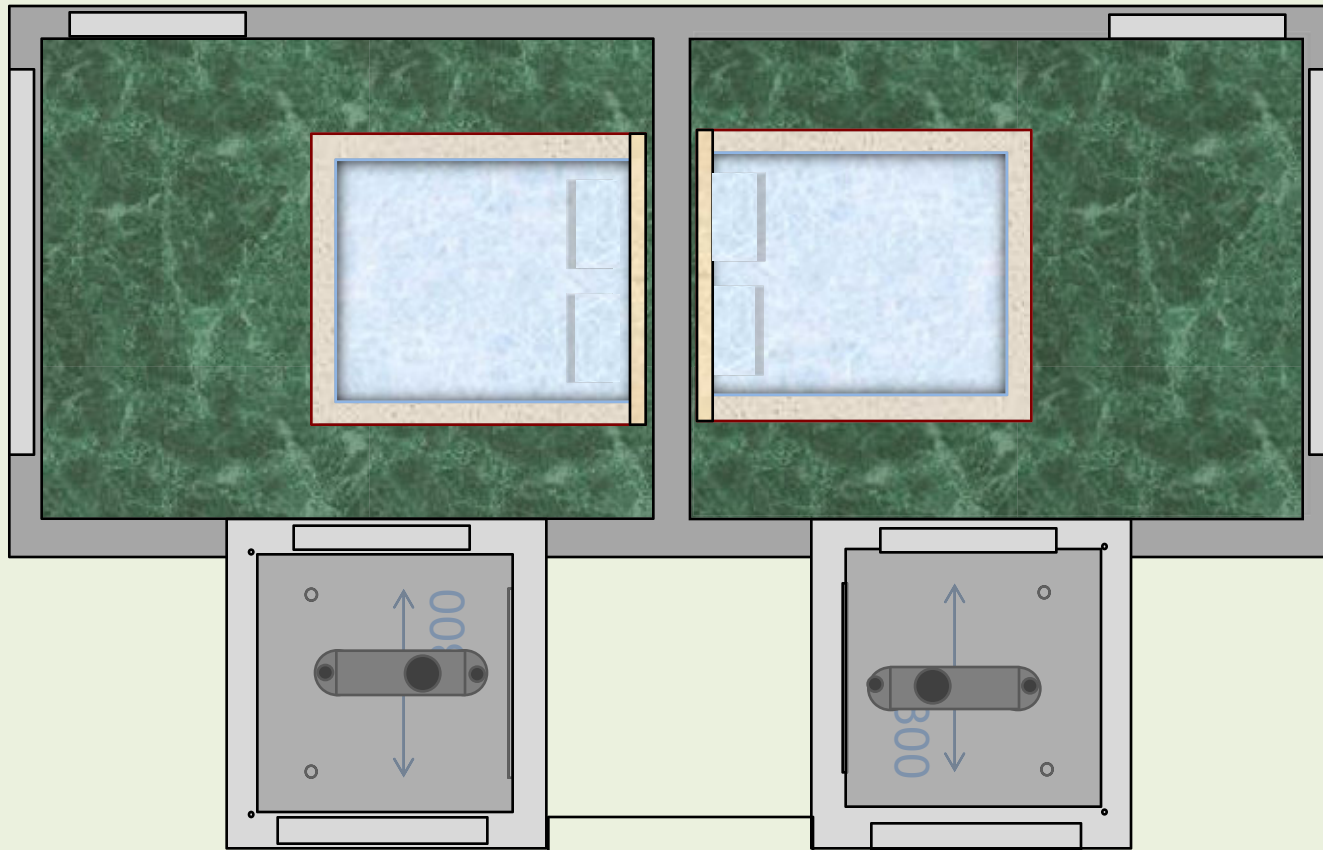

Designs for Multi-storey

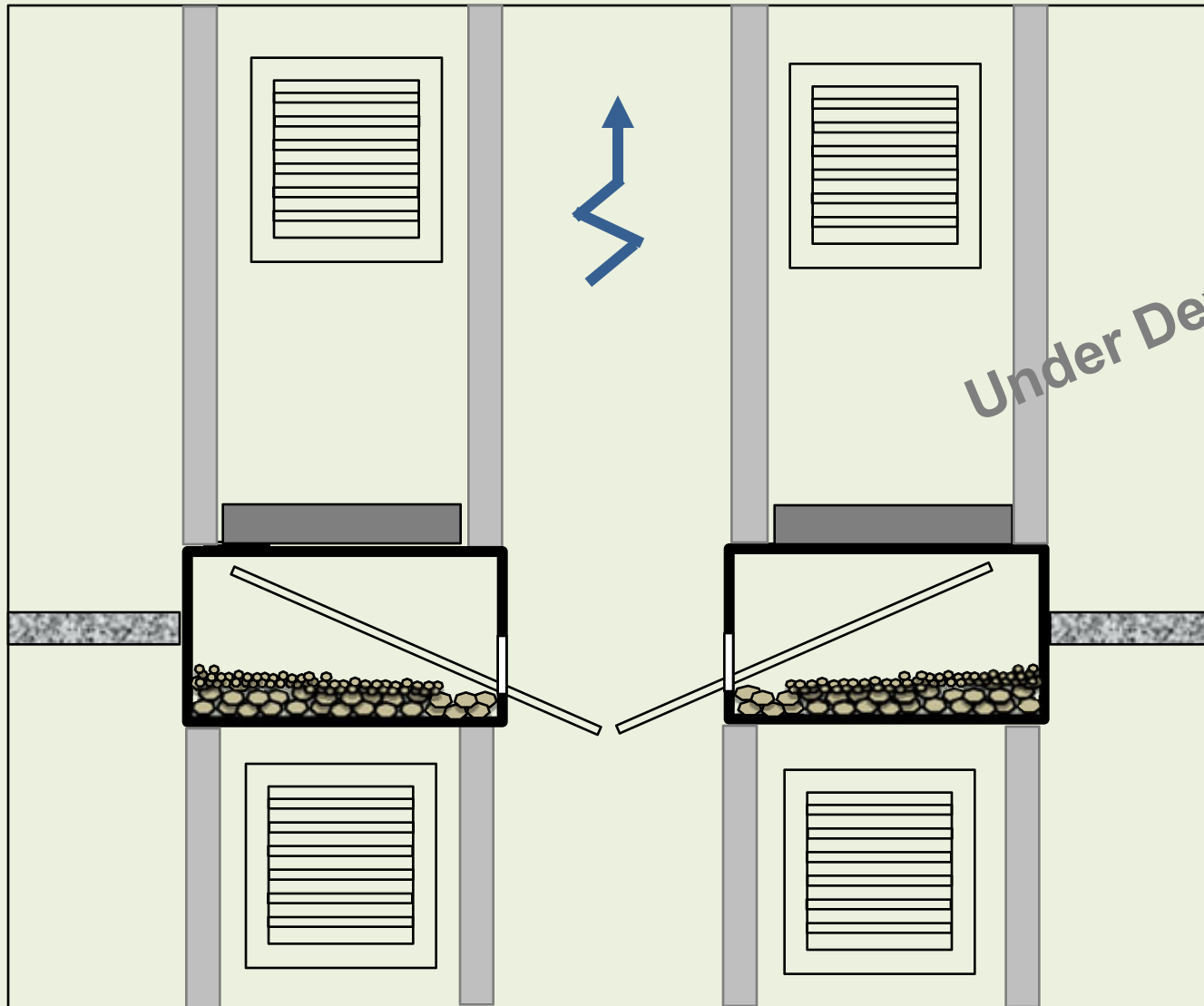

Under Development

Designs for Multi-storey

Under Development

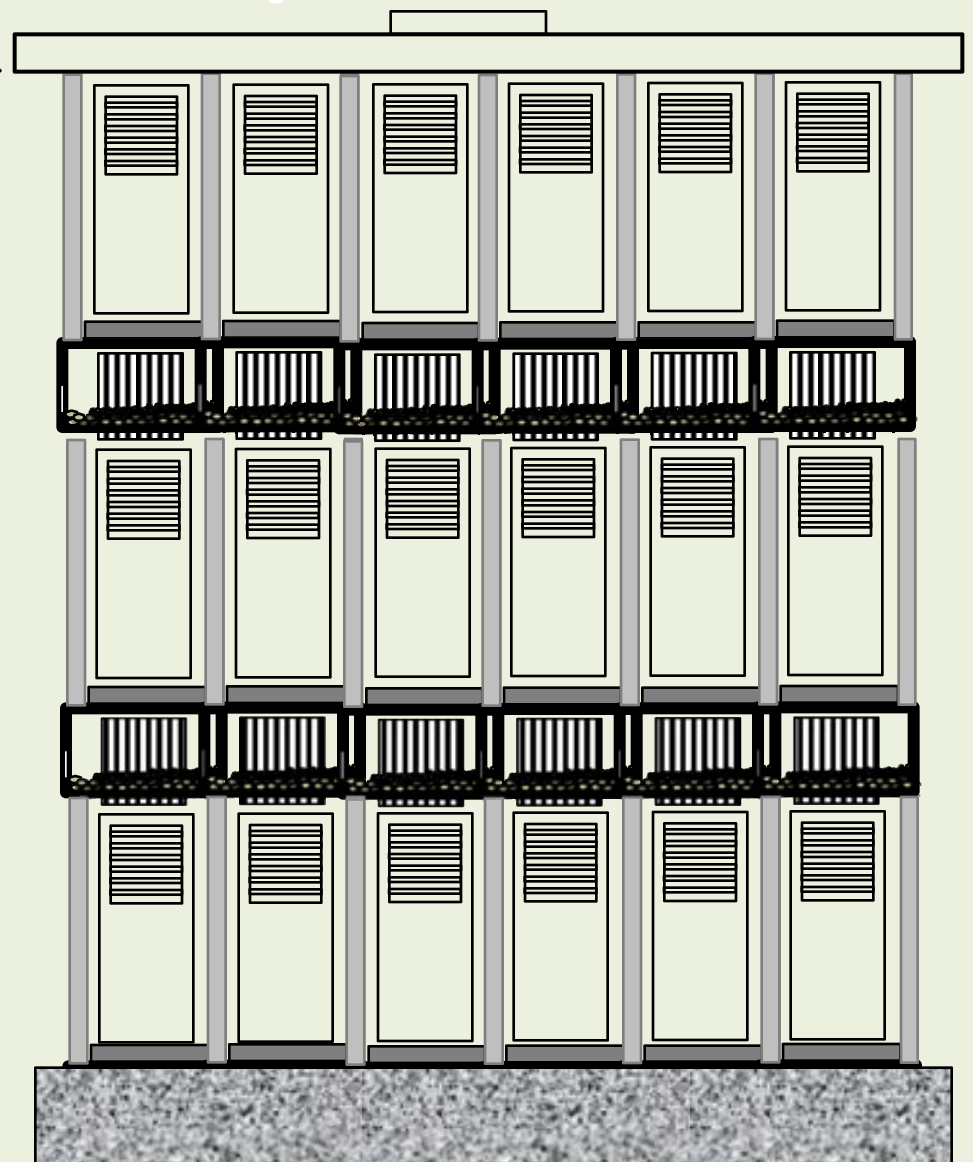
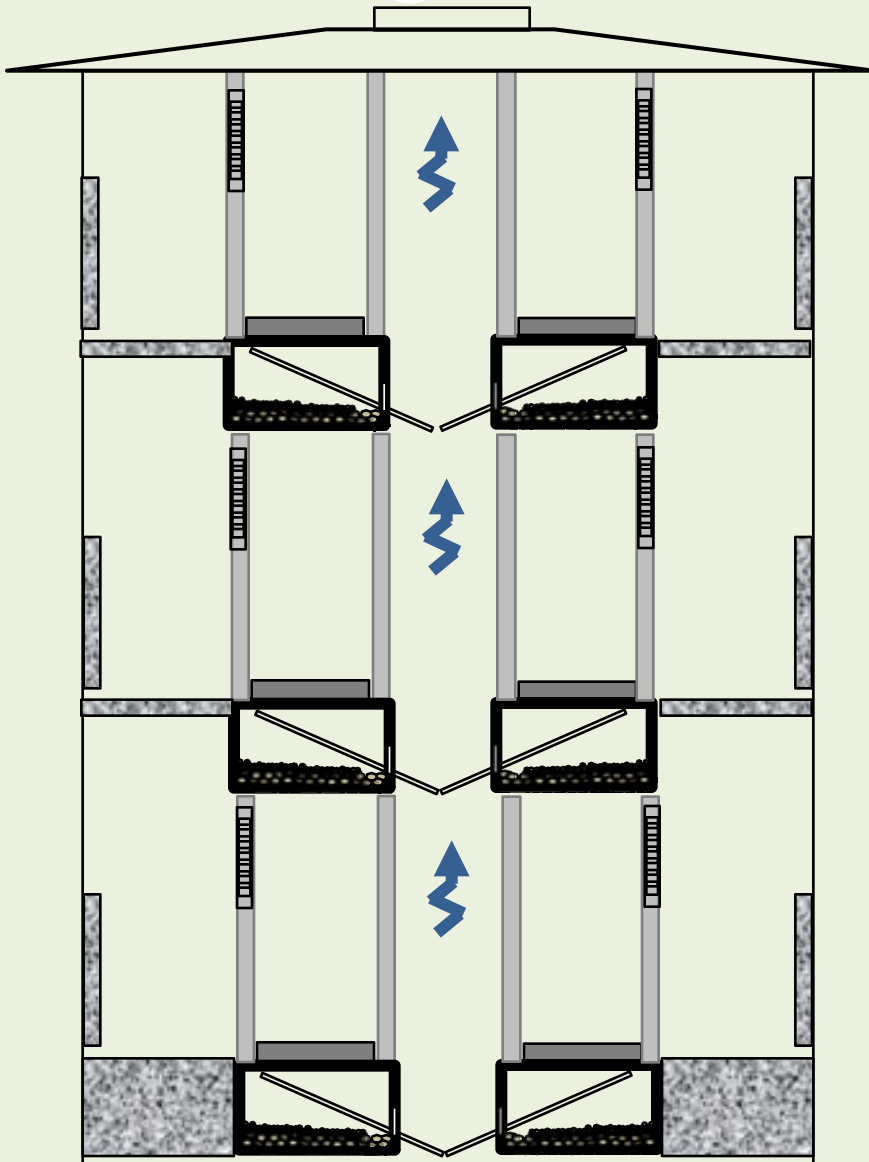

Design & Development Team

MSG Rajan

Mayank Pareek

Mohit Gupta

Swapnil Ghutke

S.Gaikwad

Raju Kamble

Raghavendra

Rupali Dhamane

K. Munshi – Professor / Principal Investigator

Advisers:

Dr. Krishna Lala

B. Bhaumik – Professor

K. Ramachandran – Professor

Support:

Ministry of Drinking Water & Sanitation



Thank You

Endorsements

i congratulate to you and your IDE team for successful development of water-less toilet - Pratik Sangave

.... opportunity for me that I could meet with such an innovative person. I saw your developed toilet for rural application , I would like to personally see that it is supplied in this area for marketing in hills - Dr SB Singh, Outstanding Scientist & DIRECTOR, Mins of Defence, DRDO,

.... warm greeting's and a hearty congratulation's to you and your team for developing the "**DRY-SAN HYGIENIC RURAL TOILET**" - Sushant Wath, CSIR-NEERI

I came to know that you innovated one toilet system which can reduce the water consumption, I am really impressed & want to Know more about it – Kashyap, Baroda

... Today we visited Bio -Toilet designed by your organisation and also you given your precious time to explain the technology. we are highly appreciate the same . Our Deptt. i.e MSDP (Slum sanitation Prog.) conducting Swatch Bharat Abhiyan . we are constructing community toilets in slum area of Mumbai Municipal Region. Kulkarni A.E I/C / Jadhav S.E

Endorsements

Very nice to hear. We could have included It in the social innovation seminar today at pune. Pl consider a paper at lccig.org . Look forward to hear from you - prof anil k gupta founder, honey bee network, National Innovation Foundation, IIM Ahmedabad

It was a pleasure meeting you and knowing about the innovative sanitation system – Rakesh BIAF

We were captivated by the Rural Toilet design - truly a simple and innovative product which would touch the lives of many people in India and rest of world - Surjit Lahiri Vice President – Technology Mindteck Ltd

..... is interested to invest in the toilet project. As told we have already started working on the same and the meetings are to be arranged in the coming two weeks - Sarang

Thank You

Hygienic Rural Toilet (dry sanitation system)

For

Durability

Longevity

Eco-Sustainability

