

Simplified Sewerage: Design Guidelines

by
Alexander Bakalian
Albert Wright
Richard Otis
Jose de Azevedo Netto



UNDP-World Bank Water & Sanitation Program

Copyright © 1994

International Bank for Reconstruction
and Development/The World Bank
1818 H Street, NW
Washington, DC 20433 USA

First printing, May 1994.

Cover photos by Alexander Bakalian and David Kinley. Other photos by Alexander Bakalian and Richard Otis.

The UNDP-World Bank Water and Sanitation Program was organized as a joint endeavor of the United Nations Development Programme and the World Bank, and it has been one of the primary actors in worldwide efforts to meet the challenge of providing basic water supply and sanitation services to those most in need in the developing world. Partners in this venture are the developing countries themselves and the multilateral and bilateral agencies that fund the Program's activities. The Program is part of the Transportation, Water and Urban Development Department of the World Bank, and has regional offices in Abidjan, Jakarta, Nairobi, and New Delhi.

The Program's publications include two series, a Water and Sanitation Program Report series and a Water and Sanitation Discussion Paper series. The Program Report series presents formal discussions of the Program's operations and research as well as examinations of relevant projects and trends within the water and sanitation sector. Program Reports are subject to rigorous external review by independent authorities from appropriate fields. The Discussion Paper series is a less formal means of communicating timely and topical observations, findings, and opinions concerning Program activities and sector issues.

This document has been prepared and published by the Program, and copies may be obtained from the Washington, DC office. Material may be quoted with proper attribution. Any maps that accompany the text have been prepared solely for the convenience of readers. The boundaries, denominations, and classifications of maps do not imply, on the part of the UNDP-World Bank Water and Sanitation Program, the United Nations Development Programme, the World Bank Group, or any affiliated organization, any judgment on the legal or other status of any territory, or endorsement or acceptance of any boundary. The findings, interpretations, and conclusions expressed in this paper are entirely those of the author(s) and should not be attributed in any manner to the UNDP-World Bank Water and Sanitation Program, the United Nations Development Programme, the World Bank Group, or any affiliated organizations.

Contents

Abstract	v
Acknowledgements	v
In Memoriam	v
1. Introduction	1
1.1 Background	1
1.2 Unconventional Alternatives: Intermediate-Cost Sewerage	2
1.3 Objectives	3
2. System Description: Origin and Development	5
3. Design Criteria	7
3.1 Layout	7
3.2 Hydraulics	7
3.3 Service Connection	9
3.4 Depth of Sewers	9
3.5 Manholes and Other Appurtenances	12
3.6 Materials	15
4. Operational Experience	17
4.1 Operational Problems	17
4.2 Maintenance Requirements	17
4.3 Equipment	17
5. Costs	19
5.1 Capital Costs	19
5.2 Operation and Maintenance Costs	19
6. Discussion	21
6.1 Risk Estimation	21
6.2 Flexibility	21
6.3 Applicability	21
6.4 Requirements	22
6.5 Additional Work	22
7. Conclusions	23
Annex 1: Design Peak Factor	25
Annex 2: Tractive Force	27
Annex 3: Examples	29
Annex 4: Cost Comparison Between Conventional and Simplified Design	31
References	33

Figures

Figure 3.1	Typical layout of simplified sewer system (SABESP)
Figure 3.2a	Connection-inspection box (Sao Paulo State, Brazil)
Figure 3.2b	Interior connection-inspection box (Sao Paulo State, Brazil)
Figure 3.2c	Interior of connection-inspection box (Sao Paulo State, Brazil)
Figure 3.3	Inspection-cleanout (SABESP)
Figure 3.4a	Typical residential connection
Figure 3.4b	Typical baffled box (Sao Paulo State, Brazil)
Figure 3.5	Minimum depths of sewers (SABESP)
Figure 3.6	Schematic of cross-block connection
Figure 3.7	Junction inspection-cleanout
Figure 3.8	Terminal cleanout (SABESP)
Figure 3.9a	Comparison of conventional and simplified manholes
Figure 3.9b	Interior of simplified manhole (Sao Paulo State, Brazil)
Figure 3.10a	Buried box for change in direction (SABESP)
Figure 3.10b	Buried box for change in slope (SABESP)
Figure A1	Elements of circular conduit

Tables

Table 1	Some Simplified Alternatives to Conventional Manholes
Table 2	Costs of Selected Simplified Sewerage Projects
Table 3	Sensitivity Analysis of Costs of Individual Design Variations in Two Egyptian Towns
Table A1	Hydraulic Elements of Circular Pipes
Table A2	Comparison of Design Results for the Two Methods

Abstract

Heavy reliance on high-cost conventional sewers has produced inadequate sanitation service coverage in many urban areas. In the recent past, low-cost, on-site systems have been gaining increased acceptance as alternatives; however, in areas where housing densities and levels of water consumption are high, waterborne solutions are required. In an effort to reduce the cost of sewer systems, a critical review of the basis of the conventional design standards has been carried out in Brazil. The result has been the development of a modified approach for sewer design based on hydraulic theory, satisfactory experience elsewhere, and redefinition of acceptable risk. Systems designed according to these new criteria are known as "simplified sewers." They operate as conventional sewers but with a number of modifications: the minimum diameter and the minimum cover are reduced, the slope is determined by using the tractive force concept rather than the minimum velocity concept, sewers are installed below sidewalks where possible, and many costly manholes are eliminated or replaced with less-expensive cleanouts. Experience with these systems has shown that cost savings of 20 percent to 50 percent have been achieved. Operation and maintenance requirements have been similar to conventional sewers.

Acknowledgements

Thanks are due to the staff and management of SABESP and SANEPAR, the water companies of the states of Sao Paulo and Parana, respectively. They have generously provided us with most of the data in this report. The authors are grateful for comments from Donald Gray, West Virginia University; James Kreissl, United States Environmental Protection Agency; John Kalbermatten, Kalbermatten Associates, Inc.; and John Briscoe and Andrew Macoun, the World Bank. Any errors or omissions are, of course, the responsibility of the authors.

In Memoriam

This work is dedicated to the memory of Jose M. Azevedo Netto, who, throughout his career, was a strong motivating force in bringing positive changes to the practice of our profession.

1. Introduction

1.1 Background

The unprecedented population explosion in urban centers during the past two decades has severely strained the ability of cities to meet the needs for services such as water supply and wastes disposal. As local governments have tried to cope with insufficient resources, their efforts have achieved mixed success. In planning for additional services, priority has generally been given to the high-income areas where full or partial cost recovery was considered feasible, and poorer sections were often left unserved or were served by woefully inadequate facilities.

Further, in low-income areas where some service has been extended, planners and users have always given a higher priority to water supply than to sanitation.¹ Uneven expansion of water coverage without parallel improvement in sanitation has increased water pollution and caused public health problems. In trying to correct the imbalance between water supply and sanitation coverage, cities face severe financial hardships in both building new sewer systems and extending existing ones.

In many cities, parts of sewerage systems built in the past either remain incomplete because of cost overruns or are underutilized because of the mismatch between supply and demand. This affects financial viability and sustainability of the

few systems that *are* built. Consequently, many plans for needed facilities have been postponed indefinitely.

One of the main reasons for this typically acute situation is the use of conventional sewerage systems. They are expensive even for industrialized countries.² To ensure that raw sewage flows freely, conventional sewers are designed with large-diameter pipes at slopes that often require extensive excavation. Flat terrain, high groundwater table, manholes, other appurtenances, and pumping stations also increase construction costs.

It is clear that exclusive reliance on conventional sewerage cannot solve the current predicament of increasing needs and dwindling resources. Recognizing the magnitude of the problem, sector institutions have begun investigating the use of alternative technologies. Much of this work has been directed at on-site systems, and the ventilated improved pit (VIP) and pour-flush latrines have emerged as technologies of choice: they provide good service at reasonable cost. However, in many situations—for example, high housing density, impermeable soil, or high water consumption—on-site systems are not appropriate. Under those circumstances, sewer alternatives to conventional sewers are needed.

-
1. It was estimated that in 1985, 66 percent of urban dwellers in developing countries had access to water, but only 35 percent were served by sanitary facilities (WHO 1988).
 2. Even in prosperous nations, serious efforts are made to find alternative sewage conveyance systems in order to reduce the costs of sanitation systems (Kreissl 1987).

1.2 Unconventional Alternatives: Intermediate-Cost Sewerage

Attempts at developing lower-cost alternatives usually focus on elements in sewerage systems that most influence costs. Among such key cost factors are the average diameter and average depth of sewers; average slope relative to ground topography; the number and depths of manholes; and other factors such as total sewer length, population density, set-up costs, and excavation in rock. Consequently, sewer cost-reducing measures have invariably been directed at modifying one or more of these cost-setting factors.

The resulting range of technological options³ is collectively known as intermediate-cost sewerage or intermediate-cost sanitation systems. There are two types of intermediate-cost sewerage: those that arise from changes in technology and those based on changes in design standards and guidelines.⁴

Changes in technology: A number of innovations have been made in the design of sewer systems through special ancillary appurtenances that permit a reduction in the depths and diameters of sewers. An example is the addition of a solids interceptor tank between house sewers and laterals. The tank captures and stores incoming solids, attenuates the flow, and allows the settled sewage to flow out by gravity. The absence of settleable solids eliminates the need for

self-cleansing velocities and permits flatter gradients and shallower depths; the attenuation of flow reduces the peak flow factor and makes it possible to use small-diameter sewers laid at mild gradients that require less excavation. First used in Zambia and Australia, this modification of conventional sewerage is known as solids-free sewers, common effluent sewerage, or small-diameter gravity sewer systems (USEPA 1986).

Another example is the septic tank effluent pump (STEP) sewerage system, similar to the solids-free sewer system except that the settled effluent is pumped out into the sewer network; this permits further reduction in pipe size and slope. Other examples are the grinder pump sewerage where wastewater is ground and pumped into the sewer line, and the vacuum sewerage system. It should be noted that these various solutions are location-specific and depend heavily on population densities and availability of strong resources for maintenance. Most of them are only suitable for populations up to 10,000. A thorough review of experience with these systems has been the subject of a recent publication from the United States Environmental Protection Agency (1991).

Changes in design standards and guidelines: Since the most costly component of conventional sewerage is the collecting system—accounting for 80–90 percent of the total cost (Kreissl 1987)—design criteria and standards can be carefully modified to achieve cost savings from the use of shallower depths, smaller pipe diameters, fewer appurtenances, etc. Such modifications have been introduced without jeopardizing the reliability and safety of the system.

-
3. The technologies discussed in this section are all self-cleaning systems. An innovative approach advocated in the Netherlands, however, questions the self-cleansing velocity method. This new approach examines the trade-off between installation and maintenance costs, and compares life-cycle costs of sewers (combined construction and operation costs) for various slopes and sizes and selecting slopes corresponding to the lowest total (DHV 1990).
 4. Another approach that would affect the size and cost of the sewer network is the use of water-saving devices. This approach could be adopted with any one of the intermediate technologies and is undoubtedly beneficial: it reduces the ever-increasing cost of water production and saves on the construction of new extensions of sewerage systems. For example, it is estimated that the use of a low-volume flush toilet (4–5 liters per flush rather than 18–20 liters) would reduce the amount of water consumed—and the amount of water discharged into the sewer—by 20 percent. It is also worth noting that a reduction in water consumption can also be achieved by pricing and legislative mechanisms. The latter has been used in the United States where effective January 1994, low volume flush toilets (not exceeding 1.6 US gallons per flush) are mandatory in new installations.

Changes in design standards to produce lower-cost sewerage have been based on hydraulic theory, advances in technology, satisfactory experience, and acceptable risk. One example is "flat-grade sewerage" in use for some 80 years in Nebraska (Gidley 1987). Based on changes in design standards affecting only the minimum diameters and minimum slopes, its use in Nebraska's flat terrain and high groundwater table produces significant cost savings during construction (saving the cost of deeper sewers, deeper manholes, dewatering during sewer laying, and pumping stations), and further savings during operation (savings in pumping costs and in the maintenance of pumping stations).

A similar system, known as "modified conventional gravity system," has been introduced in Australia (AWRC 1988) and includes modifications such as reduction of minimum cover requirements, use of PVC pipes, use of 100-mm diameter sewers, revision of trench dimensions at shallow depths, increased separation between manholes, and increased use of inspection shafts. The most extensive changes in design standards, however, have been carried out in Brazil and have resulted in a system called "simplified sewerage," the subject of this paper.

1.3 Objectives

This report presents design guidelines used for simplified sewers. It is based on information collected from a number of projects in Brazil and through discussions held with the staff of the state water companies of Sao Paulo (SABESP) and Parana (SANEPAR). Additional data from the literature and other areas are also presented.

This report is not intended to serve as a design manual. It describes changes in design criteria that have been introduced in Brazil and found to pose no significant threat to the operational integrity of sewer systems. In addition to providing an insight into the development of this new design approach, the report:

- ☛ reviews the modifications introduced to conventional design standards and presents the arguments and rationale for the modifications;
- ☛ evaluates operational experience from selected projects; and
- ☛ evaluates the cost-saving potential of the modified system.

2. System Description: Origin and Development

The principal reason for the development of simplified sewerage was the realization that the reason for the high cost of conventional sewerage was high design standards, and that these standards were hindering the expansion of service coverage to middle- and lower-income urban communities; this led to a review of design criteria used in Brazil for conventional sewerage (Azevedo-Netto 1975, 1984; Diniz 1983).

The review showed that the prevailing design criteria were very similar to (and in some cases even more stringent than) those used by George Waring Jr. in his design of the first separate sewer system in the United States in 1880.

The 1880 sewer system was designed to carry peak flows at the minimum velocity of 0.60 m/s. Waring had argued that if that velocity were reached at least once a day, the system would perform without problems. To ensure complete removal of deposits, flush tanks were installed at the head of each sewer line. Ventilation was provided through open grates on manholes spaced at least 300 m (1,000 ft) apart. Waring's system did not work very well: frequent obstructions in the 100-mm and 150-mm pipes were reported (Metcalf and Eddy 1928). The review also noted that most of these criteria and appurtenances had

survived intact or had become more conservative in Brazil and elsewhere, with very few exceptions—the flush tanks and the open-grate manholes disappeared long ago. The idea of self-cleansing sewers had become the central design criterion, and a minimum velocity of 0.6m/s was set as the design parameter. The cost of sewer systems based on century-old criteria was too high for many cities, and engineers in Brazil questioned the appropriateness of such systems in their cities.

The ensuing critical review led to sweeping changes in conventional sewer design standards. The changes were based on findings of recent research in hydraulics, satisfactory experience, and redundancy. The use of these new standards has produced a lower-cost system that uses smaller, flatter, and shallower sewers with fewer, simpler manholes.

The following section discusses the distinctive features of simplified sewerage and the supporting rationale behind changes in design standards. This system of sewer design has been adopted by a number of state water and sewerage companies in Brazil and has been incorporated into the Brazilian Sewer Code (ABNT 1988). It has also been used in Bolivia, Colombia, and Paraguay.

3. Design Criteria

3.1 Layout

To avoid deep excavations, long trunk pipes to interceptors, and large pumping stations, serious consideration is given to splitting the network into two or more separate smaller systems; although network layout is also an important part of conventional design, the optimization of pipe lengths and network subdivisions takes on even greater importance in the simplified system.

Where feasible, a project area is defined by individual drainage basins, each with its own collectors and treatment plant. As needs and resources increase, mini-networks can be connected to a common interceptor for conveyance to a regional plant or local treatment system.⁵

Furthermore, to minimize excavation and the cost of pavement restoration, sewers are, to the extent possible, located away from traffic loads, generally under the sidewalks (on both sides of the street, if necessary) rather than down the center of the street. To save pipe and excavation costs, sewers extend only to the last upstream connection rather than to the end of the block (Figure 3.1).

3.2 Hydraulics

3.2.1 Design period

In conventional design, it is common to design trunk sewers and interceptors for the projected peak flow expected during a 25 to 50-year period or for the saturation population of the area. Such long design periods make it possible to capture economies of scale in sewerage systems. However, these have to be balanced against the

opportunity cost of capital, uncertainties in predicting future land-use patterns or directions of growth in developing-country cities, and the high cost of maintaining large sewers with low flows.

The use of shorter design periods avoids such problems and reduces the large capital requirements in sewerage systems, facilitates financing, and enhances prospects of achieving greater coverage with a given investment. With shorter design periods and construction by phases, starting from upstream ends, the effects of errors in forecasting population growth and their water consumption can be minimized and corrected. For these reasons, simplified sewerage employs design periods of 20 years or less. In this regard, it is noteworthy that the USEPA limits the design period to 10–15 years (ASCE 1982).

3.2.2 Design flow

Wastewater flow quantities are necessarily lower than the quantity of water supplied because water is lost through leakage, garden watering, house cleaning, etc. To determine the expected amount of wastewater, it is important to keep records of pumpage for each day and fluctuations during the day.

Reliance on estimates of water use from industrialized countries or cities of similar characteristics can lead to erroneous design flows. Information should be obtained from the area under consideration. In arid areas of the United States, for example, the return coefficient is as little as 0.4; in Sao Paulo, this coefficient is 0.8. The design flow is based on this returned quantity multiplied by a peak factor, which is inversely related to population size.

5. To treat its waste water, the city of Juiz de Fora (population 400,000) in the state of Minas Gerais plans to build 57 communal septic tanks with anaerobic filters and 17 upflow anaerobic sludge blanket systems at a total estimated cost of \$18 million. The cost of a central conventional treatment plant and the necessary interceptors was estimated at \$75 million.

In industrialized countries, the peak factor is conservatively estimated to be between 2.0 and 3.3. In Brazil and Colombia, a peak factor of 1.8 has been used in simplified sewerage projects⁶ (see Annex 1). Where water use information is not available, the simplified sewerage system is designed for a minimum flow of 1.5 l/s; infiltration is assumed to be 0.05–1.0 l/s/km of pipe.

3.2.3 Minimum diameter

A minimum diameter for sanitary sewers is usually specified in order to avoid clogging by large objects. In conventional systems in the United States, the house connections are usually 150 mm in diameter, but smaller sizes have been used. Therefore, for conventional sewerage, the minimum diameter commonly specified for street sewers in many countries is 200 mm. In the simplified system, smaller sizes are recommended because, in the upper reaches of a system where flow is low, the use of smaller-diameter sewers results in greater depths of flow and higher velocities, and improves cleansing. Experience in Latin America and elsewhere (e.g., Nebraska) shows that 150-mm diameter street sewers do not present additional maintenance problems compared to conventional sewerage. In Brazil, 100-mm diameter laterals or branch sewers are being used in residential areas for a maximum length of 400 m. The 100-mm diameter pipes are usually specified for unpaved streets of periurban communities.⁷

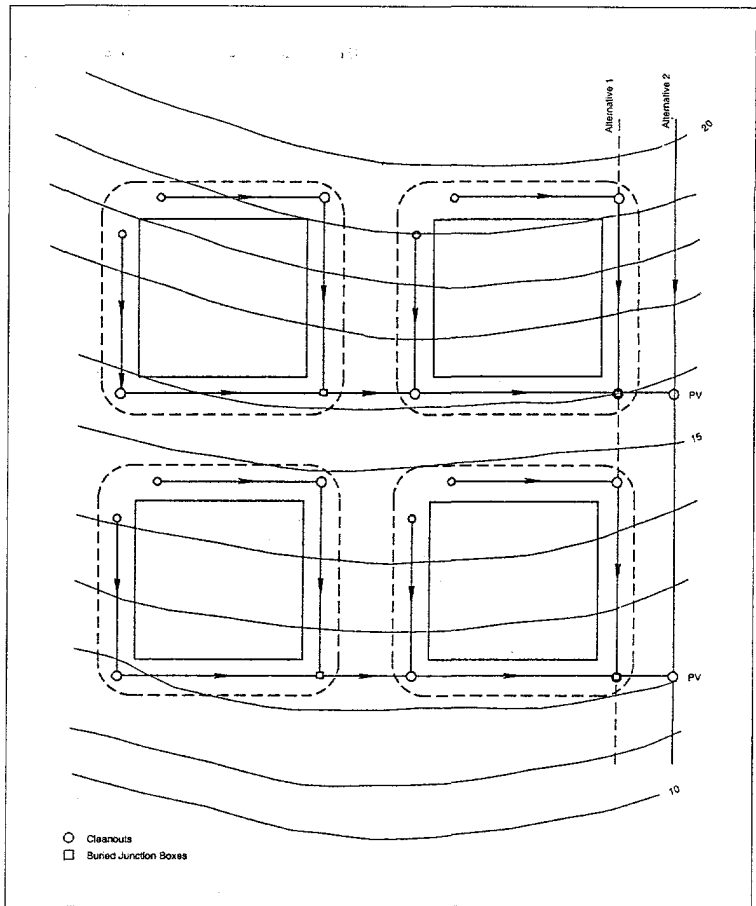

Figure 3.1. Typical layout of simplified sewer system (SABESP)

3.2.4 Ensuring self-cleansing

Instead of the minimum velocity criterion of 0.6 m/s as in conventional sewer design, simplified sewer design is based on maintaining a boundary shear stress of 0.1 kg/m², which is sufficient to resuspend a 1-mm particle of sand. Many authors (Machado 1985; Paintal 1977; Yao 1974, 1976) have proposed the use of critical shear stress for determining the minimum slope of sewers as a economical alternative to the minimum velocity approach. For a minimum shear stress of 0.1 kg/m², pipes smaller than 1,050 mm can be made flatter than when de-

6. This factor is the product of two ratios: (a) K_1 , the ratio of the maximum day flow over the average day flow (equal to 1.2), and (b) K_2 , the maximum hour flow over the average hour flow (equal to 1.5). In other words, the maximum sewage flow will be the hourly maximum, or the peak rate of the maximum day (plus the maximum infiltration).

signed according to the minimum-velocity approach, and pipes larger than 1,050 mm should be made steeper to maintain self cleansing. In Brazil, for design of simplified sewers, the following equation is used:

$$I_{\min} = 0.0055 Q_i^{-0.47}$$

where I_{\min} is the minimum slope of the sewer and Q_i is the initial flow in l/s (current flow). For derivation and use of this equation, refer to Annex 2; to compare the advantages of this method over the conventional minimum velocity method, see Annex 3.

3.3 Service Connection

In the simplified design, a 60-cm square or circular connection (or inspection) box is placed between the building and the service line. All sewers or drains from the house or building enter the box. It is usually located under the sidewalk

in the public right of way (Figures 3.2a, 3.2b, 3.2c). A simpler cleanout could be substituted (Figure 3.3).

In certain areas of Sao Paulo, where the risk of obstruction is believed to be high (e.g., in commercial establishments), baffled boxes have been added downstream of each building sewer (Figures 3.4a, 3.4b), in addition to the connection or inspection box. Baffled boxes are usually 60 cm x 60 cm x 80 cm concrete boxes with underflow baffle located approximately 60 cm from the inlet. Their purpose is to prevent trash and other large settleable solids from entering the sewer. Their maintenance is usually the responsibility of the homeowner.

3.4 Depth of Sewers

At the starting point of laterals the minimum depth at which pipes are laid should suffice to (a) make house connections and (b) have a layer



Figure 3.2a. Connection-inspection box (Sao Paulo State, Brazil)

7. Although the most commonly recommended minimum diameter for conventional systems in the United States is 200 mm, a number of states and other countries such as France and the United Kingdom have adopted the minimum size of 150 mm. However, if there is evidence that the smaller pipes would add to operational problems, it would be more economical to install the next-larger size and avoid repetitive servicing and user dissatisfaction.

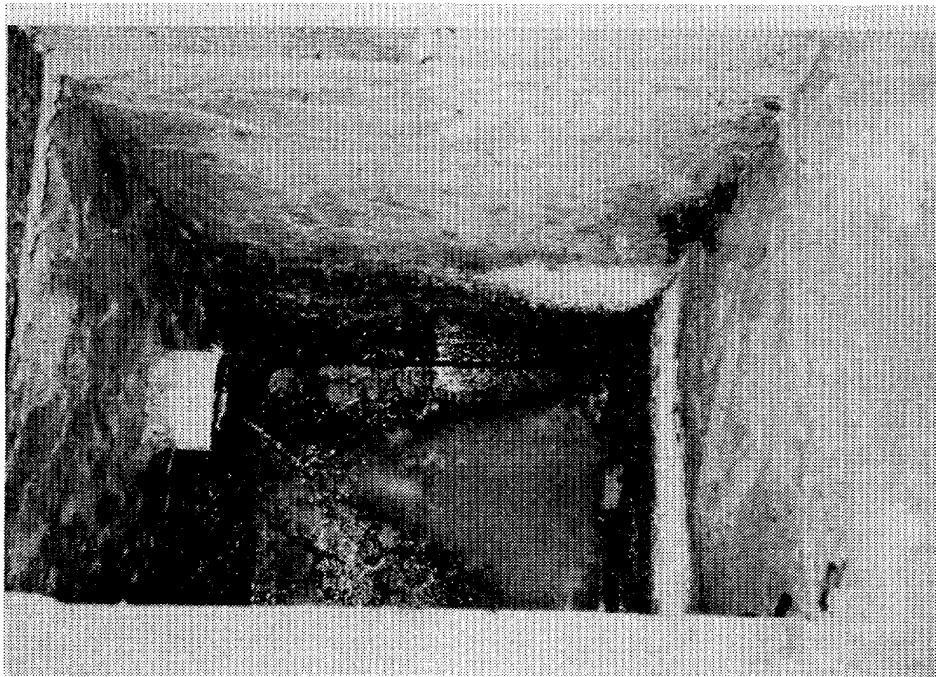

Figure 3.2b. Interior of connection-inspection box (Sao Paulo State, Brazil)

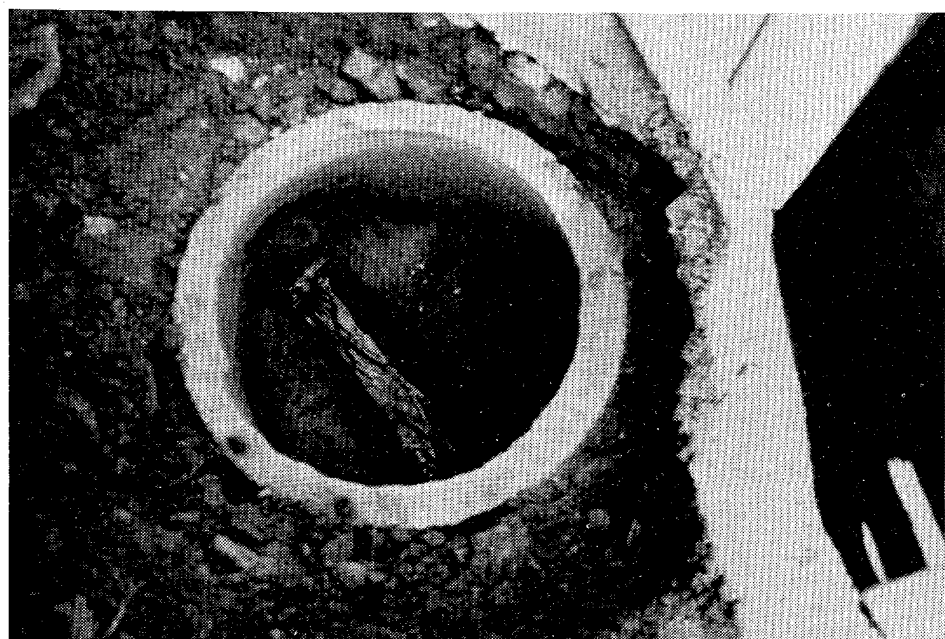

Figure 3.2c. Interior of connection-inspection box (Sao Paulo State, Brazil)

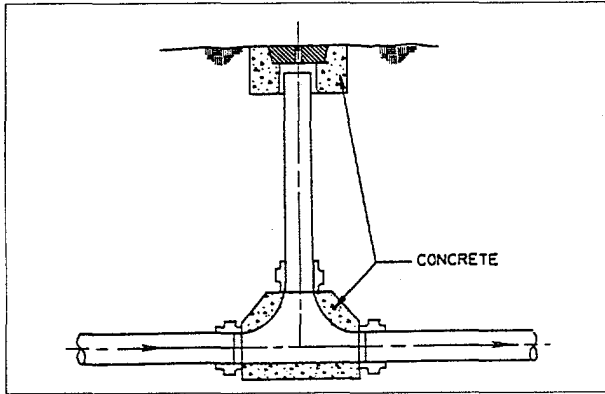

Figure 3.3. Inspection-cleanout (SABESP)

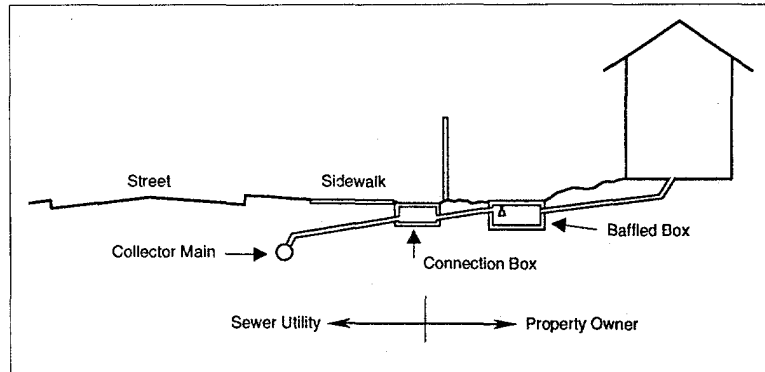

Figure 3.4a. Typical residential connection

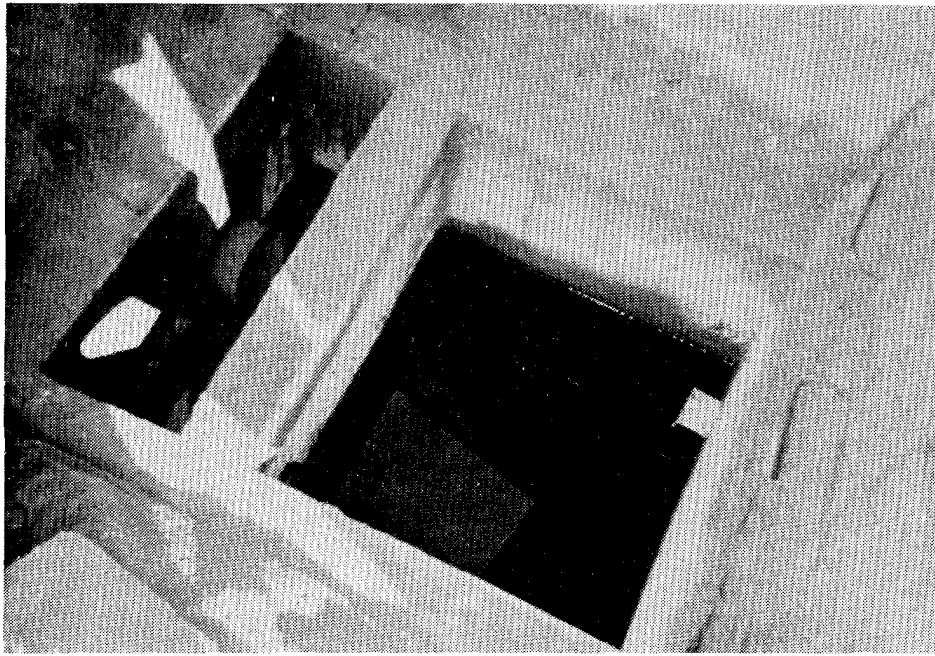

Figure 3.4b. Typical baffled box (Sao Paulo State, Brazil)

of soil over the crown to protect the pipe against structural damage from external loads and frost. In conventional design, there is no one method for determining the minimum depth of sewer as long it satisfies the above criteria. However, some rules of thumb suggest that (1) the top of the sanitary sewer should not be less than 1 m below the basement and (2) where there is no basement, the invert of the sanitary sewer should not be less than 1.8 m below the top of the foundation.

In the simplified system, typical minimum sewer depths are much shallower: 0.65 m below sidewalks, 0.95–1.50 m below residential streets (depending on the distance from the street centerline and the amount of traffic), and 2.5 m below heavily traveled streets⁸ (Figure 3.5). Building elevations are not considered in setting the invert elevation of the sewers. If buildings along the

mains are too low for connections by gravity, it is the responsibility of the property owner to find other means of making a connection. In cases where topography permits, it may be necessary to use a longer building sewer to be able to connect to a service line, provided easements can be obtained from the neighboring owners (Figure 3.6). In this context, it is noteworthy that the Brazilian Code disallows direct connection of fixtures installed below the street level.

3.5 Manholes and Other Appurtenances

Manholes are an expensive component. They are now among the most familiar features of a sewer system, but they were not widely used in

8. The determination of the minimum depth should still be made with regard to live and impact loads, pipe material (3-edge bearing strength), and bedding class (ASCE/WPCF 1982). The minimum depth of sewers proposed for the modified system (0.9 m cover) would be ample for a 600-mm extra-strength clay pipe (ASTM C 700) with 4,400 lb/ft three-edge bearing strength under the 10,000-lb weight of a truck wheel and with saturated topsoil backfill and class-C bedding (compacted granular bedding). Therefore, the depth of the sewer would not be dictated by a predetermined criterion but by the pipe, bedding, and backfill types. Project designers could also look into the cost effectiveness of deeper excavations compared to the use of higher-strength materials in shallower trenches.

early sewers. They came into wide use with combined systems where they facilitated removal of grit. The criteria for manhole use have gradually become more conservative and have contributed significantly to the high cost of sewerage. The cost of manholes is a function of depth, spacing, and strength of design. The use of shallower depths is one way to reduce these costs.

Early sewer systems used simple appurtenances such as lampholes. Some variations of these earlier systems are being reintroduced in Brazil, for example, the inspection tube (Figure 3.7) and the terminal cleanout (Figure 3.8). The former is similar to the old lamphole, and the latter replaces manholes at the upstream ends of sewer lines.

The present requirement of placing manholes about 100 m apart was introduced when sewers were cleaned with rods and canes. The use of modern cleaning equipment calls for a review of manhole location and spacing guidelines.

In conventional systems, manholes are generally located at (i) the upper ends of all laterals, (ii) changes in direction and slope, (iii) pipe junctions, except building connections, and (iv) at intervals not greater than 100 m for pipes up to 600 mm diameter, and at less than 120 m for sewers between 700 mm and 1,200 mm diameter. In the United Kingdom the distance between manholes has been changed from 110 m to 180 m (Escritt and Haworth 1984); however, for the Cairo sewerage project in the late 1970s as little as 35 m between manholes was proposed for sewers less than 250 mm (Taylor & Sons, Binnie and Partners 1977).

In light of experience in Brazil, the simplified system is designed with these guidelines:

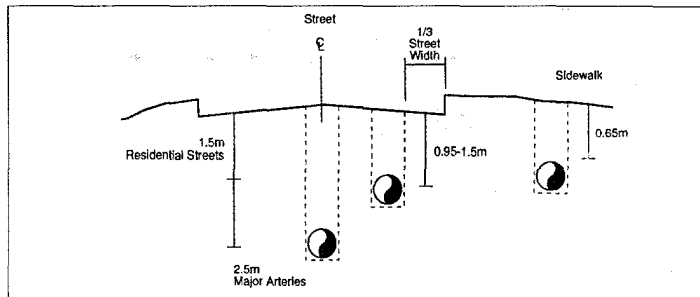

Figure 3.5. Minimum depths of sewers (SABESP)

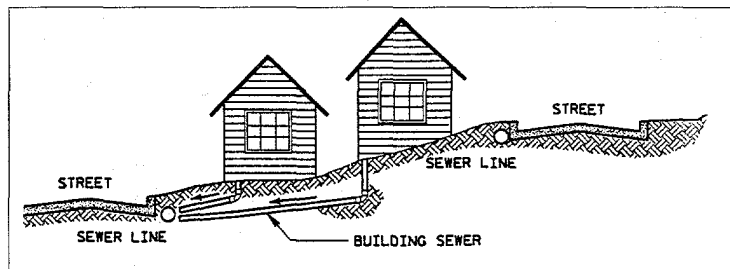

Figure 3.6. Schematic of cross-block connection

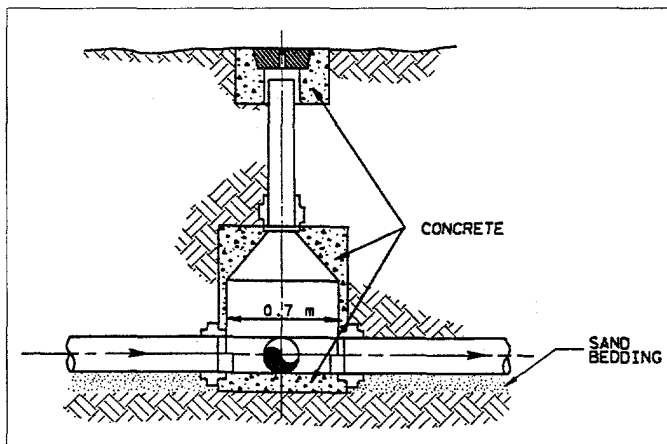

Figure 3.7. Junction inspection-cleanout

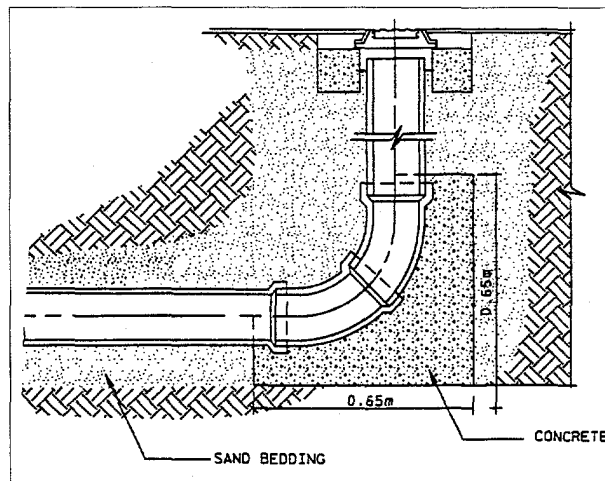

Figure 3.8. Terminal cleanout (SABESP)

Where possible, conventional manholes are replaced with “simplified” manholes, cleanouts, or buried boxes, and manholes are used only at major junctions. Simplified manholes (Figures 3.9a, 3.9b) are similar to conventional manholes, but they are reduced in size from 1.5 m to 0.6–0.9 m diameter. The need for maintenance personnel to enter the manholes is eliminated by the shallower depths and the availability of modern hydraulic cleaning equipment; for small sewers, and where infiltration is not a major concern, manholes can be built with precast concrete pipes or concrete rings with precast slabs and bottoms.

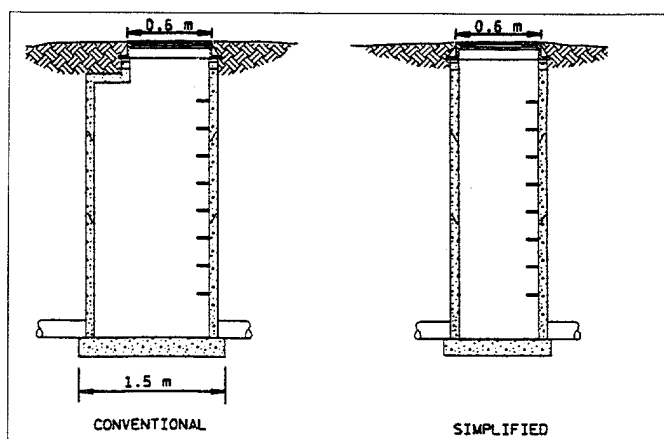

Figure 3.9a. Comparison of conventional and simplified manholes

- Manholes at changes of direction or slope are replaced by simple underground boxes or chambers (Figures 3.10a, 3.10b);
- House connections are adjusted to serve as inspection devices as well; a small box is built under the walkway and connected to the sewer with a curve of 45 degrees and a “Y” (the cleaning rod is introduced through this box).

These guidelines for the design of manholes considerably lower the costs of the system, espe-

cially since up to 90 percent of manholes are never opened. In 1881 Waring wrote, “It seems to me decidedly advantageous to use inspection pipes, or even lampholes on 6-inch and 8-inch sewers, rather than build manholes and inspection chambers” (USEPA 1986).

There are situations, however, where manholes should not be eliminated: (i) very deep sewers (more than 3 m), (ii) slopes smaller than required, (iii) sewers with drops, and (iv) points of connections from certain commercial and industrial establishments, i.e., points of sampling and flow

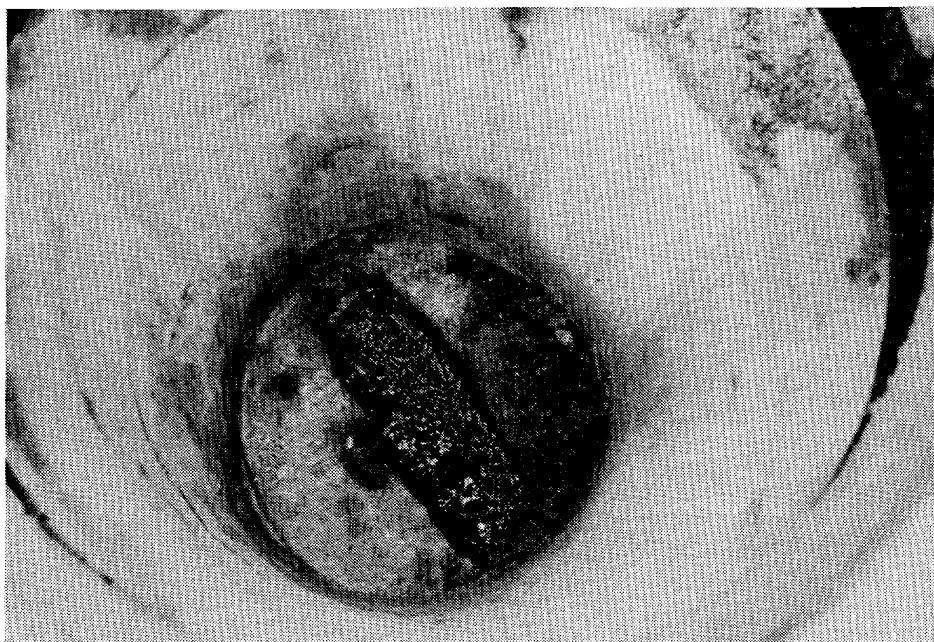

Figure 3.9b. Interior of simplified manhole (Sao Paulo State, Brazil)

measurements. Guidelines for manhole replacement are summarized in Table 1.

3.6 Materials

The types of pipe materials used in simplified sewerage are similar to those used in conventional sewers. Those most frequently used in Brazil for simplified sewerage are vitrified clay, asbestos cement, and polyvinyl chloride (PVC) pipes. The vitrified clay pipes, generally 90 cm long, are considered ideal for sewers due to their

durability and resistance to corrosion. These pipes are, however, especially suitable when the water table is low. On the other hand, PVC pipes offer the advantage of longer sizes, fewer joints (i.e., less infiltration), light weight, watertightness, and uniformity.

Mortar is commonly used for vitrified clay pipe joints. However, SANEPAR also uses okum and asphalt. Rubber gasket joints are commonly used with plastic and fiber concrete pipe.

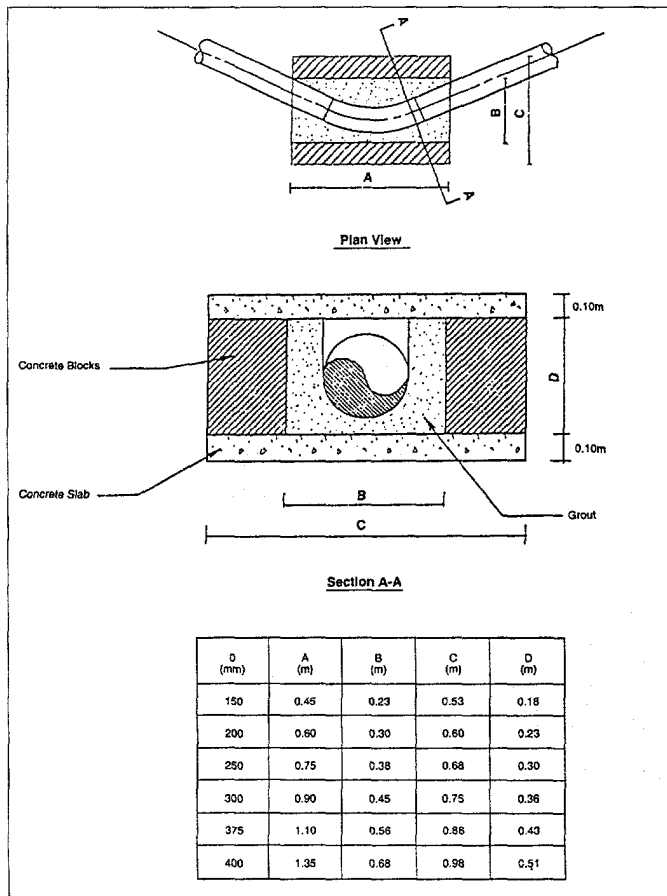

Figure 3.10a. Buried box for change in direction (SABESP)

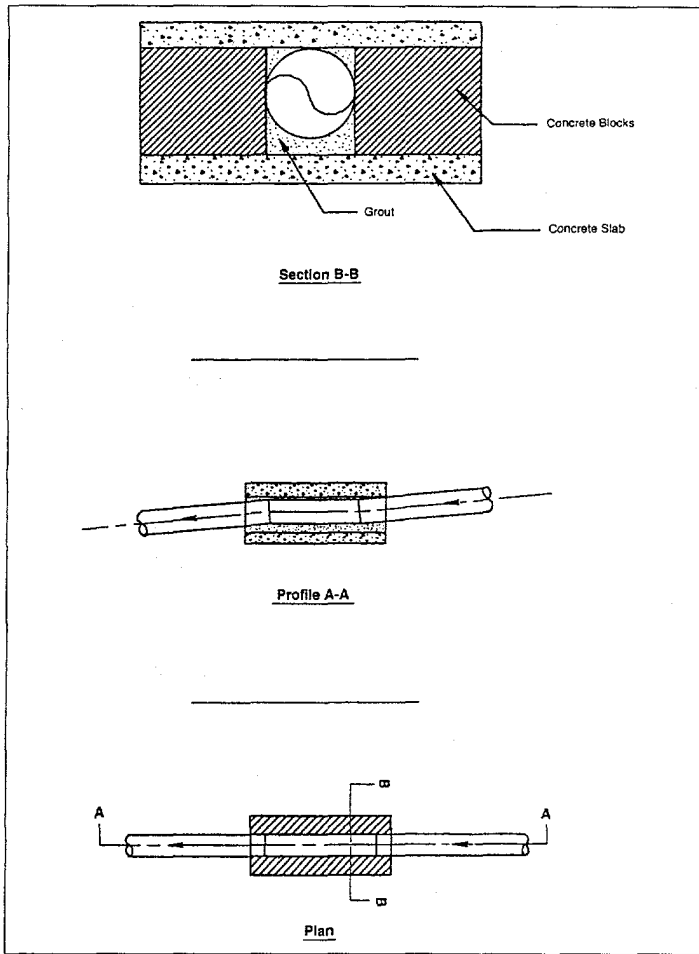

Figure 3.10b. Buried box for change in slope (SABESP)

Table 1: Some Simplified Alternatives to Conventional Manholes

Situation	Solution
Starting point of a sewer	Inspection & cleaning terminal
Long straight sewer	Intermediate inspection tube
Horizontal curve of 90 degrees	Two separate 45-degree curves
Service connection	Y branch and one 45-degree curve
Change of diameter	Underground concrete box
Change of slope	Underground concrete box

4. Operational experience

4.1 Operational Problems

Simplified sewerage systems were first adopted in Brazil in early 1980s (Sao Paulo⁹ and Parana) and have subsequently been applied in other parts of Latin America. Although specific data on operational problems are not readily available, it is known that no significant problems have been reported. In Sao Paulo, it has been estimated that there are about 75 obstructions per 1,000 km of sewers each month. (Further data collection in this area is under consideration.) The infrequent occurrence of obstruction supports the strategy of minimizing the number of manholes. Engineers in SABESP reckon that it would be economical to install only a few manholes initially and install additional ones as needed (i.e., at points of frequent obstructions).

Similarly, field surveys have reported no problems related to excess hydrogen sulfide generation. Although no measurement or monitoring has been indicated, the designer should calculate the potential for sulfide concentration in a new system.

4.2 Maintenance Requirements

Preventive maintenance consists of inspection of the system and analysis of existing data regarding

past history of trouble areas, which gives maintenance crews some guidance where and how often preventive maintenance should be performed and the type of maintenance that would be effective. The requirements for preventive maintenance are similar to those of a conventional system. *Minimum* maintenance includes cleaning, flushing, repairs, and supervision of connections and disconnections (WPCF 1985). To be effective, the program should, at the very least, include:

- ☛ determination of the types of problems and trouble areas with a closed circuit camera, by visual surface, or by direct inspection, and by keeping an information data base;
- ☛ prompt removal of any accumulation of foreign material; and
- ☛ occasional flushing of the sewer lines.

4.3 Equipment

There are different types of cleaning equipment and methods an agency could select depending on budget, facilities, and the experience of the staff. A survey of simplified systems in Brazil shows that the cleaning devices most commonly used are rodding machines and flushing equipment; use of the latter is increasing rapidly.

9. As of 1988, in Sao Paulo State alone this technology has been adopted in 26 cities. Plans to adopt it are being made for at least 36 other cities.

5. Costs

5.1 Capital Costs

Simplified sewers have been shown to cost significantly less than conventional systems. In many places, cost savings of from 20 percent to 50 percent have been reported. In the State of Sao Paulo, Brazil, the first projects have shown a construction cost reduction of 30 percent; but after about 8 years of experience, the cost reductions are estimated to more closely approximate 40 percent. The cost reduction in sewage collecting systems in the city of Sao Paulo is reported to be 35 percent.

SABESP estimates the following average construction costs (1988 prices) for small towns (not including the per capita costs of treatment and house connection, which are approximately \$40 and \$50, respectively):

Conventional systems \$150-\$300/capita
 Simplified systems \$80-\$150/capita

Table 2 summarizes cost information on some of the systems reviewed for this paper. The cost per person varies between \$51 and \$151.

The total savings that these modifications generate will depend on the number of modifications that are deemed feasible in a particular project, given factors such as population density, topography, soil and water conditions, etc. For example, in a sensitivity analysis of costs of different design choices carried out in Egypt, savings of up to 23 percent were shown to be achievable (Table 3). In another project in Bogota, Colombia, it was estimated that the cost saving would be about 50 percent. Annex 4 shows a breakdown of cost savings.

5.2 Operation and Maintenance Costs

No cost data on operation and maintenance have been made available from this survey. It may be

Table 2: Costs of Selected Simplified Sewerage Projects

	----- Sao Paulo state -----			Parana state
	Sao Paulo	Cardosa	Coraodos	Toledo
Total cost of collection system	\$1,897,000	\$48,125	\$68,194	\$3,762,066
Population served	13,200	950	780	65,500
Average cost per meter of sewer	\$76	\$13	\$8	\$21
Average cost per person	\$151	\$51	\$87	\$59

difficult to separate operating costs for the simplified system from the overall operation and maintenance cost of a large utility company such as SABESP, but it should be possible to obtain this information from the systems that are inde-

pendently operated and maintained by the municipalities under the umbrella of SABESP. It is important to obtain this information to make meaningful cost comparisons between simplified sewerage and other alternatives.

Table 3. Sensitivity Analysis of Costs of Individual Design Variations in Two Egyptian Towns

(Figures are percentages of the total cost of alternative A.)

	Beni Suef	Kafr el Shokr
A Conventional standard	100.0	100.0
B Houses connected to sewer lines (instead of manholes)	92.4	90.3
C Manhole spacing 50% greaterer than conventional	97.8	98.0
D Lighter manhole covers (80 kg and 175 kg instead of 285 kg)	96.1	96.1
E No manhole at upstream end of branch	NA	NA
B + C	86.9	83.0
C + D	93.9	94.6
B + C + D	83.2	80.1
B + C + D + E	77.3	76.3

Source: Gakenheimer and Brando 1984

6. Discussion

6.1 Risk Estimation

The present conventional engineering practice in sewer design was introduced more than a century ago and has changed little since. More than a decade ago, engineers in Brazil took a close look at the rationale for design criteria and found ample room for change and simplification without jeopardizing the operational integrity and safety of the system.

It is common knowledge that engineering design is not conceived exclusively on the basis of rigid, exact scientific facts; it is rather heavily based on empirical data supplemented with probability and risk criteria. The safety coefficients embedded in many design criteria (design flow, minimum diameter, depth of sewers, etc.) should not be uniformly applied in all situations. For example, there is no valid reason to apply the same conservative standards in business districts, where breakdowns and repairs could cause heavy economic loss and great inconvenience, as in the outskirts, where the impact of a malfunction is more limited.

In addition to economic aspects, the probability of breakdowns should be a prime consideration in design of a sewerage system. While Gakenheimer and Brando (1983) suggest additional research on uncertainty as it relates to infrastructure standards, they argue that there is enough evidence to move away from the stringent standards prevalent in industrialized countries. They contend that "when resource-limited countries are using conservative standards, risk is lowered in one locality at the cost of fully exposing another."

6.2 Flexibility

Despite the fact that most (if not all) of the criteria discussed in this report have been integrated in the Brazilian code, flexibility in the use of criteria is unavoidable. In fact, the basic pillar of the philosophy behind the revision of the conventional standards has been the strategy of selecting standards to fit existing conditions. Since the resources needed to provide sanitation services are huge, even a small percentage reduction in the total cost translates into large savings. Moreover, the use of the simplified sewerage design approach does not necessarily require the use of all the modified criteria: the designer is called to make professional judgements about specific standards that could be used under given circumstances.

6.3 Applicability

The simplified sewerage systems were first implemented in Brazil (Sao Paulo state¹⁰ and Parana State), and later applied in Bolivia (Cochabamba and Oruro), and Colombia (Bogota and Cartagena). New projects using this approach in design are being considered for the towns of Chilayo, Peru, San Bernardino, Paraguay, and Kumasi, Ghana.

The simplified sewerage system differs from a conventional system only in the standards applied in the design. Since most of the major cities in Brazil already had conventional sewerage in central districts prior to the introduction of simplified sewerage, the current experience with this new system has been mainly in the periurban areas and secondary towns. Since most of the modified standards are based on sound analysis, it would be safe to assume that they could be

10. As of 1988, in Sao Paulo State simplified sewerage systems were implemented in about 30 locations and were being planned for at least 36 more.

applied in any design, recognizing their limitations which are generally obvious.

6.4 Requirements

Since simplified sewerage is not fundamentally different from the conventional sewerage except in the levels or values of design criteria, the institutional requirements for their use are also generally similar. In the case of the two water companies using this system that were visited in Brazil during this work, no changes had been adopted in their procedures service provision.

However, even though the anecdotal evidence does not indicate any increase in operational problems in the areas covered in this report, one cannot discount an intuitive tendency among sector professionals to anticipate additional operational requirements for simplified sewerage. Where this is the case, a strengthening of the operation and maintenance capability of the water company should be given upfront consideration.

6.5 Additional Work

This new approach for designing sewer systems was introduced in the early 1980s and is considered an "infant" technology. This review, which was based on a small number of projects, is one of the first attempts to document and disseminate the experience. To increase confidence in the technology, additional research is warranted. The following are suggestions for further work:

- ☛ A parallel field evaluation of a simplified sewer system and a comparable conventional system. The purpose of this study would be to monitor, evaluate, and compare directly the operational problems of both systems, initially for a six-month observation period with possibility of continuing over a longer period.
- ☛ The long-term problems of the systems, for example, corrosion, generation of sulfides and methane, etc. Since some of these systems have been in place for periods ranging from under one year to eight years, it is recommended that studies be carried out to identify levels of sulfides at selected locations in the system.
- ☛ More complete information on cost variation between different types of simplified systems, and cost comparisons with conventional systems. In particular, difference in operation and maintenance costs are needed for complete cost comparisons.
- ☛ Survey of how current design criteria vary among industrialized countries (and within certain countries, for example, the various states of the United States); a similar survey (in the United States only) conducted in 1942 showed a large variation in the design criteria used in different parts of the country (Boston Society of Civil Engineers 1942).
- ☛ Field measurement of flow variations in different parts of a city. Most designs have relied on peak factors determined in developed countries. These factors may be excessive and could be modified for use in different developing countries.

7. Conclusions

A concerted effort to review, adopt, and disseminate these modified criteria would be a timely initiative, given the tremendous needs of developing countries for sanitation services and the potential for large savings.

This paper has presented information on simplified sewerage, a design strategy based primarily on experience from Brazil that offers a new cost-saving approach to the design of sewer systems. The review has shown that the system is the equal of conventional sewerage in effectiveness. It is based mainly on cost-saving rational changes in long-standing traditional sewer design standards. The review shows that:

- ☛ simplified sewerage technology is being applied successfully, and it is a viable, lower-cost alternative to conventional systems;
- ☛ design modifications introduced in simplified sewerage systems are based on sound engineering principles;
- ☛ the new design approach does not create a sub-standard level of service; it rationalizes design standards without sacrificing quality or lowering the level of service;
- ☛ simplified sewerage systems cost a fraction of what conventional systems cost and therefore make funds available to extend service coverage to larger populations; and
- ☛ the cost of simplified sewerage can be reduced further through use of community-participation methods of service provision as applied in condominial sewerage in Brazil or as used in the Orangi project in Pakistan.

Little is known about the system outside Brazil. Engineers in other parts of the world will become more familiar with simplified sewerage as experience is accumulated and reported. A growing number of cities are discovering that the simplified system is attractive, and they are achieving considerable cost savings by making use of it.

Annex 1: Design Peak Factor

In conventional design, the peak factor is determined from curves developed from data gathered in industrialized countries. Although it is usually recommended to generate local data to estimate this factor, these curves are commonly used. In simplified sewer design, emphasis is put on estimating the peak factor for the city under consideration from flow measurement records. If records are not available, efforts should be spent to generate them quickly to avoid overdesigning the system. The peak factor will depend on a number of elements such as the contribution of the commercial, industrial, and institutional wastewater, and the social and economic make-up of the area under design.

Although SANEPAR recommends using the factors mentioned in the main text of this report, Freitas (1989) has used SANEPAR data to propose a set of equations (derived from fitting curves to a set of six data points) for the calculations of these factors:

$$K_2 = -10.848 + 19.656 K_1 - 7.801 K_1^2$$

$$K_1 = [-19.651 + (47.653 - 31.205 K_2)^{1/2}] / -15.603$$

According to this study, which also draws on other reports, in small communities (under 10,000) with commercial and institutional users, K_1 is between 1.0 and 1.1. This gives K_2 values between 1.0 and 1.3.

Annex 2: Tractive Force

The tractive force method is a design process that is widely used in the design of open channels. Like the minimum velocity design methodology, it is based on the concept of "threshold of movement" and makes use of the minimum force required to move a certain size of settled particle. The resistance equation is given by

$$\tau = \Gamma R I \quad (1)$$

where τ is the boundary shear stress, Γ is the specific weight of water, R is the hydraulic radius, and I is the slope of the conduit. The minimum design slope is derived by incorporating equation (1) into Manning's equation:

$$Q = (1/n) * A * R^{2/3} * I^{1/2} \quad (2)$$

and solving for the minimum slope with the assumption that the depth of the minimum flow is two tenths of the diameter; the hydraulic elements for this condition are derived from geometric relationships in Figure A.1

$$\cos \theta/2 = 1 - 2d/D$$

therefore, for $d/D = 0.2$, $\theta = 106.26$. The corresponding cross-sectional flow area is

$$A = D^2/4(\pi\theta/360 - \sin\theta/2)$$

$$A = 0.1118 D^2 \quad (3)$$

and the hydraulic radius

$$R = (D/4)(1 - 360\sin\theta/2\pi\theta)$$

$$R = 0.1206 D \quad (4)$$

Inserting equation (4) in equation (1), the diameter D can also be expressed as

$$D = \tau / 0.1206 \Gamma I \quad (5)$$

Inserting (3) and (4) into (2), and then replacing D by its equivalent given in (5), with $\Gamma = 1,000 \text{ kg/m}^3$, Manning's equation becomes

$$Q = 7.687 * 10^{-8} * (1/n) * (\tau^{8/3}) * I^{-13/6} \quad (6)$$

Assuming $n = 0.013$ and $\tau = 0.1 \text{ kg/m}^2$ and expressing Q in l/s, equation (6) can be solved for the minimum slope

$$I_{\min} = 0.0054 Q^{-0.462} \quad (7)$$

(The equation proposed in Machado [1985] is $I = 0.0055 Q^{-0.47}$; the observed differences are probably due to rounding off.)

To complete the design, the following procedure is suggested, which is similar to the one presented by Yao (1974):

1. Solve equation (7) for I_{\min} using the initial flow, Q_i
2. Compute $Q_f/I^{0.5}$ where Q_f is the flow at the end of the design period, m^3/s .
3. Find the value of $Q_f/I^{0.5}$ in Table A.1 where d/D is closest to and preferably less than 0.75 (d/D is the ratio of depth of flow to the pipe diameter). Select the corresponding pipe diameter D as the minimum size of the sewer pipe.
4. Compute the final flow velocity, V_f , from the corresponding value of $V/I^{0.5}$ given in the table. Check if V_f is less than 5 m/s.
5. Compute the critical velocity $V_c = 6(gR)^{0.5}$ where g is the acceleration of gravity and R is the hydraulic radius; to ensure adequate ventilation, check if V_f is less than V_c ; if not go back to step 3 and select a new diameter which corresponds to a value of d/D closest to 0.5 instead of 0.75.

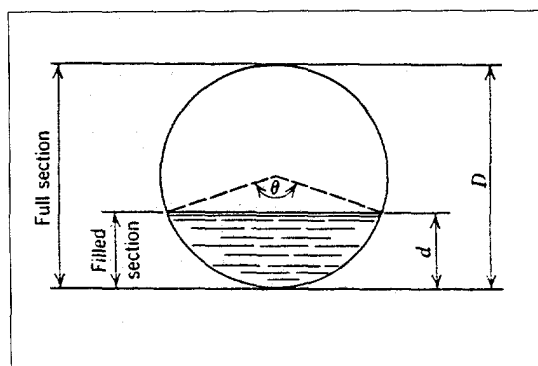

Figure A1. Elements of Circular Conduit

Table A1. Hydraulic Elements of Circular Pipes Based on Manning's Equation

(Q in m³/s, I in m/m, V in m/s)

d/D	DIAMETER (m)																
	0.100	0.150	0.200	0.250	0.300	0.375	0.400	0.450	0.500	0.500							
0.025	V/I**0.5 Q/I**0.5	1.4064	0.0002	1.7037	0.0004	1.9770	0.0006	2.2325	0.0011	2.5905	0.0019	2.7044	0.0023	2.9253	0.0031	3.1381	0.0041
0.050	V/I**0.5 Q/I**0.5	2.2147	0.0007	2.6829	0.0016	3.1132	0.0029	3.5155	0.0046	4.0793	0.0084	4.2586	0.0100	4.6084	0.0137	4.9416	0.0181
0.075	V/I**0.5 Q/I**0.5	2.8785	0.0017	3.4870	0.0037	4.0463	0.0068	4.5982	0.0110	5.3020	0.0200	5.5350	0.0237	5.9871	0.0324	6.4227	0.0430
0.100	V/I**0.5 Q/I**0.5	3.4583	0.0032	4.1893	0.0068	4.8612	0.0124	5.4884	0.0202	6.3698	0.0368	6.6498	0.0435	7.1930	0.0595	7.7163	0.0789
0.125	V/I**0.5 Q/I**0.5	3.9792	0.0051	4.8204	0.0109	5.5935	0.0198	6.3163	0.0322	7.3293	0.0584	7.6515	0.0694	8.2785	0.0950	8.8707	0.1258
0.150	V/I**0.5 Q/I**0.5	4.4550	0.0074	5.3968	0.0159	6.2623	0.0289	7.0716	0.0470	8.2057	0.0852	8.5684	0.1013	9.2661	0.1386	9.9403	0.1836
0.175	V/I**0.5 Q/I**0.5	4.8941	0.0102	5.9286	0.0219	6.8795	0.0397	7.7685	0.0645	9.0144	0.1170	9.4107	0.1390	10.1793	0.1903	10.9199	0.2520
0.200	V/I**0.5 Q/I**0.5	5.3021	0.0133	6.4229	0.0287	7.4530	0.0521	8.4161	0.0847	9.7659	0.1536	10.1952	0.1824	11.0279	0.2497	11.8303	0.3307
0.225	V/I**0.5 Q/I**0.5	5.6830	0.0169	6.8844	0.0384	7.9885	0.0660	9.0208	0.1074	10.4676	0.1947	10.9277	0.2313	11.8203	0.3166	12.6803	0.4193
0.250	V/I**0.5 Q/I**0.5	6.0400	0.0209	7.3168	0.0449	8.4902	0.0815	9.5874	0.1325	11.1250	0.2402	11.6141	0.2853	12.5627	0.3906	13.4768	0.5173
0.275	V/I**0.5 Q/I**0.5	6.3752	0.0252	7.7228	0.0542	8.9614	0.0983	10.1195	0.1599	11.7425	0.2899	12.2587	0.3443	13.2599	0.4714	14.2247	0.6243
0.300	V/I**0.5 Q/I**0.5	6.6904	0.0298	8.1047	0.0642	9.4046	0.1165	10.6199	0.1894	12.3231	0.3434	12.8049	0.4079	13.9156	0.5584	14.9281	0.7396
0.325	V/I**0.5 Q/I**0.5	6.9872	0.0348	8.4642	0.0749	9.9217	0.1359	11.0909	0.2209	12.8697	0.4006	13.4355	0.4758	14.5328	0.6514	15.5902	0.8627
0.350	V/I**0.5 Q/I**0.5	7.2665	0.0401	8.8028	0.0863	10.2144	0.1564	11.5344	0.2543	13.3843	0.4611	13.9727	0.5477	15.1139	0.7498	16.2136	0.9930
0.375	V/I**0.5 Q/I**0.5	7.5295	0.0456	9.1212	0.0981	10.5840	0.1780	11.9518	0.2894	13.8696	0.5246	14.4783	0.6232	15.6608	0.8531	16.8003	1.1299
0.400	V/I**0.5 Q/I**0.5	7.7768	0.0513	9.4207	0.1105	10.9316	0.2004	12.3443	0.3259	14.3240	0.5909	14.9537	0.7019	16.1751	0.9609	17.3520	1.2726
0.425	V/I**0.5 Q/I**0.5	8.0090	0.0573	9.7020	0.1234	11.2580	0.2237	12.7129	0.3638	14.7518	0.6596	15.4003	0.7835	16.6582	1.0726	17.8702	1.4206
0.450	V/I**0.5 Q/I**0.5	8.2267	0.0634	9.9657	0.1366	11.5640	0.2477	13.0584	0.4029	15.1528	0.7304	15.8189	0.8676	17.1109	1.1877	18.3559	1.5730
0.475	V/I**0.5 Q/I**0.5	8.4302	0.0697	10.2123	0.1502	11.8502	0.2723	13.3816	0.4428	15.5277	0.8029	16.2103	0.9537	17.5343	1.3056	18.8101	1.7292
0.500	V/I**0.5 Q/I**0.5	8.6200	0.0762	10.4422	0.1640	12.1169	0.2974	13.6827	0.4836	15.8772	0.8768	16.5751	1.0414	17.9290	1.4257	19.2334	1.8882
0.525	V/I**0.5 Q/I**0.5	8.7961	0.0827	10.6555	0.1780	12.3645	0.3228	13.9823	0.5249	16.2016	0.9516	16.9138	1.1304	18.2953	1.5475	19.6284	2.0494
0.550	V/I**0.5 Q/I**0.5	8.9588	0.0892	10.8526	0.1921	12.5932	0.3484	14.2206	0.5665	16.5013	1.0271	17.2267	1.2200	18.6337	1.6701	19.9895	2.2119
0.575	V/I**0.5 Q/I**0.5	9.1082	0.0958	11.0336	0.2063	12.8031	0.3740	14.4577	0.6082	16.7764	1.1027	17.5139	1.3098	18.9444	1.7931	20.3227	2.3748
0.600	V/I**0.5 Q/I**0.5	9.2442	0.1023	11.1983	0.2204	12.9943	0.3996	14.6735	0.6498	17.0269	1.1781	17.7754	1.3994	19.2273	1.9157	20.6262	2.5372
0.625	V/I**0.5 Q/I**0.5	9.3668	0.1088	11.3468	0.2344	13.1667	0.4249	14.8682	0.6910	17.2527	1.2528	18.0112	1.4881	19.4823	2.0372	20.8998	2.6981
0.650	V/I**0.5 Q/I**0.5	9.4759	0.1152	11.4790	0.2481	13.3200	0.4499	15.0413	0.7316	17.4536	1.3264	18.2209	1.5755	19.7091	2.1569	21.1431	2.8565
0.675	V/I**0.5 Q/I**0.5	9.5711	0.1215	11.5944	0.2616	13.4539	0.4743	15.1925	0.7713	17.6291	1.3984	18.4041	1.6610	19.9073	2.2738	21.3557	3.0115
0.700	V/I**0.5 Q/I**0.5	9.6523	0.1275	11.6927	0.2747	13.5680	0.4980	15.3214	0.8097	17.7786	1.4681	18.5602	1.7439	20.0762	2.3873	21.5369	3.1618
0.725	V/I**0.5 Q/I**0.5	9.7189	0.1334	11.7734	0.2872	13.6616	0.5207	15.4271	0.8467	17.9013	1.5352	18.6883	1.8235	20.2147	2.4964	21.6855	3.3063
0.750	V/I**0.5 Q/I**0.5	9.7704	0.1389	11.8357	0.2991	13.7340	0.5424	15.5088	0.8819	17.9961	1.5990	18.7872	1.8993	20.3217	2.6002	21.8003	3.4436
0.775	V/I**0.5 Q/I**0.5	9.8059	0.1441	11.8788	0.3103	13.7839	0.5627	15.5652	0.9149	18.0615	1.6599	18.8555	1.9704	20.3956	2.6975	21.8795	3.5725
0.800	V/I**0.5 Q/I**0.5	9.8244	0.1489	11.9012	0.3209	13.8099	0.5814	15.5946	0.9454	18.0956	1.7140	18.8911	2.0359	20.4341	2.7872	21.9209	3.6913
0.825	V/I**0.5 Q/I**0.5	9.8246	0.1532	11.9014	0.3297	13.8101	0.5982	15.5948	0.9728	18.0914	1.7637	18.8914	2.0949	20.4344	2.8680	21.9212	3.7983
0.850	V/I**0.5 Q/I**0.5	9.8045	0.1570	11.8770	0.3380	13.7819	0.6129	15.5629	0.9966	18.0589	1.8069	18.8527	2.1463	20.3926	2.9382	21.8763	3.8914
0.875	V/I**0.5 Q/I**0.5	9.7614	0.1601	11.8249	0.3447	13.7214	0.6250	15.4946	1.0162	17.9796	1.8425	18.7700	2.1885	20.3031	2.9961	21.7803	3.9680
0.900	V/I**0.5 Q/I**0.5	9.6914	0.1623	11.7401	0.3496	13.6230	0.6339	15.3835	1.0308	17.8507	1.8689	18.6354	2.2199	20.1575	3.0391	21.6241	4.0249
0.925	V/I**0.5 Q/I**0.5	9.5879	0.1637	11.6147	0.3525	13.4775	0.6390	15.2192	1.0391	17.6600	1.8840	18.4363	2.2378	19.9422	3.0636	21.3932	4.0574
0.950	V/I**0.5 Q/I**0.5	9.4386	0.1637	11.4339	0.3525	13.2676	0.6391	14.9822	1.0392	17.3851	1.8842	18.1493	2.2381	19.6317	3.0639	21.0601	4.0578
0.975	V/I**0.5 Q/I**0.5	9.2134	0.1617	11.1611	0.3493	12.9511	0.6315	14.6247	1.0269	16.9703	1.8618	17.7163	2.2115	19.1633	3.0275	20.5576	4.0096
1.000	V/I**0.5 Q/I**0.5	8.6200	0.1523	10.4422	0.3280	12.1169	0.5948	13.6827	0.9672	15.8772	1.7536	16.5751	2.0829	17.9290	2.8515	19.2334	3.7765

