

# Low-Cost Sustainable Sanitation Solutions for Mindanao and the Philippines

A Practical Construction Field Guide

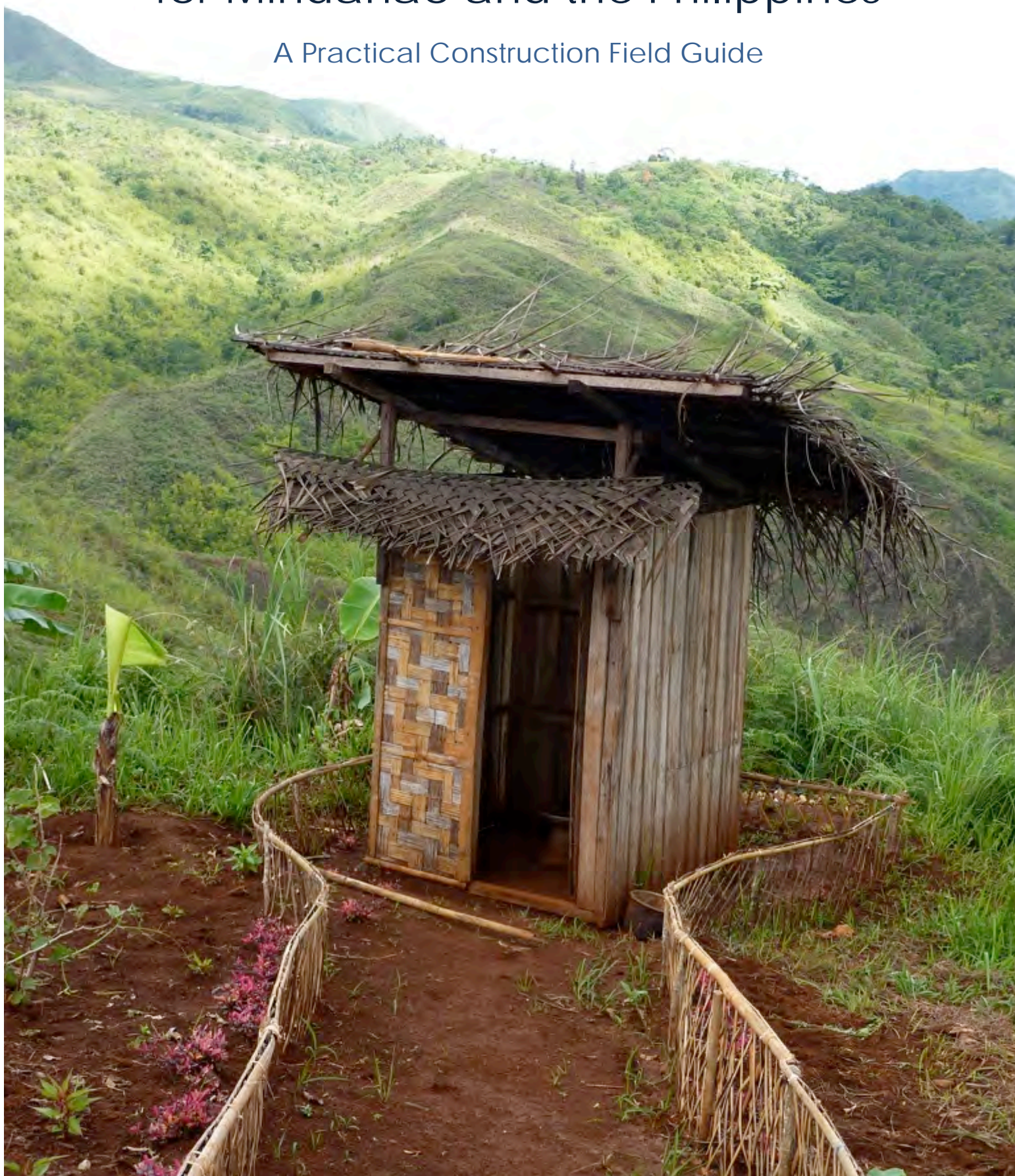

Center for International Migration and Development  
a collaboration of CIM and the  
German Technical Cooperation Agency

partner of

sustainable  
sanitation  
alliance

## published by



Xavier University Press  
Xavier University – Ateneo de Cagayan  
Corrales Avenue, Cagayan de Oro City  
Philippines 9000  
Email: xupress@xu.edu.ph

## co-sponsors



Water, Agroforestry, Nutrition & Development (WAND Foundation)  
Lubluban, Libertad  
Misamis Oriental  
Philippines 9021



Center for Advanced Philippine Studies (CAPS)  
120-A K-8<sup>th</sup> Street  
East Kamias, Quezon City  
Philippines  
Homepage: [www.caps.ph](http://www.caps.ph)

## authors

Robert Gensch, Analiza Miso, Gina Itchon, Elmer Sayre

## acknowledgement

We would like to thank the following persons and organizations for their invaluable contributions to this manual: Dexter Lo and Donah Marie Achas from the XU Engineering Resource Center (ERC), the XU engineering students Jim Croce Nabua, Lou Menard Casero, Peter Gamones and Kerk Jay Montefalcon, May Grace Maboloc, John Diel Sayre and all WAND Foundation support staff, field workers and carpenters, Dan Lapid from the Center for Advanced Philippine Studies (CAPS), The Philippine Ecosan Network, Johnny Cabreira, Rosa Kuipers from Waste Netherlands, the former XU Periurban Vegetable Project (PUVeP), the Center for International Migration and Development (CIM) as well as all participants from the toilet construction course in May 2010 in Libertad, Misamis Oriental.

Copyright © 2010 Xavier University Press

All rights for commercial/for profit reproduction or translation, in any form, reserved. The publisher authorizes the partial reproduction of this material for scientific, educational or research purposes, provided that the publisher and the source document are properly acknowledged. Permission to reproduce the document and/or translate in whole, in any form, whether for commercial or non-profit purposes, must be requested in writing. Requests for reprint or other inquiries should be directed to the XU Sustainable Sanitation Center or Xavier University Press.

ISBN 978-971-9094-08-1

# Low-Cost Sustainable Sanitation Solutions for Mindanao and the Philippines

A Practical Construction Field Guide



Xavier University Press  
2010



*T*his Sustainable Sanitation Practical Construction Field Guide is great; it is appropriate and timely. It is all these because we now have a practical manual to guide those in need of proper sanitation without going far and wide and spending so much to obtain necessary materials to build a clean, safe and decent toilet. Building a proper toilet is now affordable, socially and culturally acceptable, and therefore sustainable at the household and community level. The importance of this field guide should not be taken for granted because there are more than 20 million Filipinos suffering from the indignities and health hazards of not having access to proper sanitation. This manual is addressed to the needs of the 10 million Filipinos still practicing open defecation, the millions of households that are too poor to afford their own toilets, those in remote areas un-served by government services, those with inadequate or no supply of clean water, and those in conflict and disaster-hit areas. This field guide can now put a stop to the old and, often times, inappropriate practice of doling out pour-flush toilet bowls by government and donor organizations, even though we know they are well meaning.

This manual will also benefit our sanitation professionals. It represents new knowledge available at the tip of the fingers of sanitation advocates, promoters and practitioners. There is new knowledge in this manual on Ecosan approaches and technologies, like UDDT, Arborloo and EcoPee. And true to the principles of Ecological Sanitation, it promotes the safe reuse of human urine and feces as fertilizers, a key feature in sustainable sanitation. If distributed widely and used adequately, it can greatly advance our efforts in trying to meet our MDG target for sanitation. It is a milestone in the sanitation movement in the Philippines.

On behalf of the Center for Advanced Philippine Studies and the Philippine Ecosan Network, I would like to congratulate the Xavier University Sustainable Sanitation Center and WAND Foundation for writing and publishing this field guide. To the authors, I know for a fact that this publication embodies your commitment, sacrifices and life's work to help the poor attain healthy lives and healthy environment and sufficiency in food security. I thank you for making me and CAPS a part of this publication.

Dan Lapid

President/Executive Director, Center for Advanced Philippine Studies  
Secretary General, Philippine Ecosan Network  
Coordinator, Philippine Knowledge Node for Sustainable Sanitation

# content

1 sanitation challenge in the Philippines	1
2 introduction to sustainable sanitation	3
3 low-cost sustainable sanitation options	5
the arborloo toilet	5
the one-chamber UDDT (ecosan toilet)	17
the two-chamber UDDT (ecosan toilet)	31
the hanging UDDT (hanging ecosan)	43
the ecopee	49
4 management of the sanitation system	53
the system approach	53
collection and transport	54
treatment options	58
reuse of urine, feces and composting products	60
5 further Information, useful links and contacts	62

# rationale of the field guide

The concept of sustainable sanitation is slowly gaining popularity in the Philippines. Many good practices all over the country exist, showing that a more sustainable approach to sanitation is not only technically and financially feasible but also socially acceptable and the huge amount of human excreta produced daily can be turned into a productive resource without polluting the environment.

However, despite the fact that there is a great variety of existing sustainable sanitation technology options, many of the proposed solutions are still too expensive to be easily affordable and replicable in poorer communities in the Philippines and, therefore, often not an appropriate solution at the household level. While the general idea and the need for a more reuse-oriented, safe sanitation system is often well understood and appreciated by communities and local governments, financial resources are often lacking to successfully kick-start local action. Hence, there is a need to find solutions that lower these costs and empower communities to implement sanitation systems on their own.

The Periurban Vegetable Project (PUVeP) of Xavier University and the WAND Foundation, a local NGO in Misamis Oriental, Mindanao, and active in the field of ecological sanitation for many years, put a lot of effort into the development of locally appropriate low-cost sustainable sanitation alternatives by adopting and adapting the design of existing technologies and by using cheap, locally available and partly recycled materials for the construction of the toilet infrastructure. Many of those toilets have been implemented in the last years in Misamis Oriental.

In order to further spread knowledge gained from these experiences, the WAND Foundation in close collaboration with the Sustainable Sanitation Center of Xavier University - Ateneo de Cagayan offered several basic hands-on training courses on how to construct these sanitation facilities. Since not everyone showing interest can also visit areas where actual implementation is being done, the idea was born to put all this information into a small handbook aiming to give people practical, easy-to-understand and mostly picture-based information on how to successfully construct different low-cost sanitation options in the Philippine setting.

After a brief introductory chapter on the Philippine sanitation situation and basic principles of sustainable sanitation, the manual focuses on the introduction of different low-cost sanitation solutions comprising the arborloo toilet, the 1-chamber and 2-chamber UDDT, hanging UDDTs, and the ecopee urinal. Each technology is briefly described by giving general information on how it works, operation and maintenance requirements, reuse or safe disposal options, and in which setting this technology might be appropriate. In addition, a picture-based guide on how to construct each technology is provided as well as the necessary technical drawings and rough cost estimates based on current prices. Since a sanitation system does not end with the toilet itself, the last chapter also provides information on the overall management of the system including collection, transport, treatment, and final reuse of urine, feces and composting products in agriculture. Additional references are provided on where to get further information and on institutions and organizations active in this sector in the Philippines.

# sanitation challenge in the Philippines

The Philippines has made significant progress in recent years with regard to improving the country's sanitation situation and seems to be on track in reaching the sanitation Millennium Development Goal (MDG): To reduce by half the population without access to basic sanitation until 2015. Currently, some estimated 76% of the total population has access to improved sanitation (JMP 2008).

However, still around  $\frac{1}{4}$  of the entire population is not served with individual sanitary types of sanitation facilities and an estimated number of 10 million Filipinos are still defecating in the open every single day with serious environmental and public health consequences.

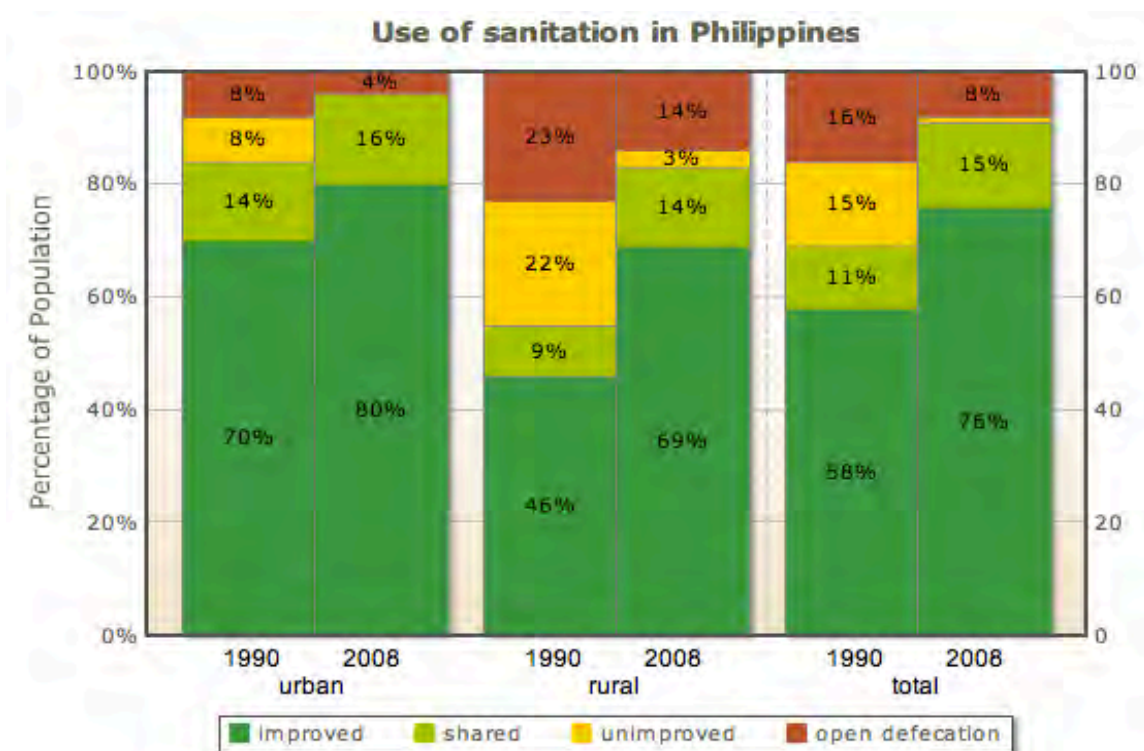

WHO/UNICEF Joint Monitoring Programme (JMP): <http://www.wssinfo.org/datamining/graphs.html>

The SUSEA (Sustainable Sanitation in East Asia) program has recently confirmed that sanitation remains a critical public health and environmental problem that needs to be addressed in a more sustainable manner. Some of the findings include:

- Access to basic sanitation in specific target communities is much lower than the national average, usually in low-income communities and those living on fragile environments, such as above water bodies, isolated islands, and remote inlands.
- Those without toilets defecate in the open fields, shorelines, and along rivers.
- Most septage and wastewater flow to open canals, rivers and other water bodies.
- Large number of communities do not have any visible drains.

Furthermore, the term 'sanitary toilets' does not necessarily refer to satisfactory sanitation under an environmental, health and social point of view. The existing sanitation solutions in the country (e.g. pit latrines and septic tanks) most often fail to treat and sanitize excreta properly and the pathogenic load is most often directly discharged into the environment. It is estimated that more than 90% of pathogen-rich (but also nutrient-rich) wastewater in the country is discharged without appropriate treatment, contributing heavily to pollution of water sources. In fact 58% of the country's groundwater resources are contaminated and about 64% of all rivers exceed the drinking water criterion (Philippines Environment Monitor, 2003).

Most sanitation solutions are still water based, using precious water resources for the transport of waste despite the ever-increasing scarcity and degrading quality of national freshwater resources. In many upland areas in the Philippines for instance, water is already a scarce resource and people have to carry it over long distances. Women and children are especially at a disadvantage because they are often the once tasked to carry and transport the water. Toilet types using water for flushing are therefore not a feasible option, hence many people choose to defecate in the open or use an open pit latrine instead.

A look at the national health statistics reveals that diarrhea (the most common waterborne disease caused by poor sanitation) is the 2<sup>nd</sup> cause of infant mortality and the 5<sup>th</sup> cause of adult mortality in the country despite the fact that diarrhea is a preventable disease. A recent study of the Worldbank Water and Sanitation Program showed that the deaths of around 20,000 Filipinos every year can be attributed to poor sanitation (WSP-EAP, 2008).

The same study showed that the estimated overall economic losses from poor sanitation amount to about US\$ 1.4 billion or PhP 77.8 billion every year (WSP-EAP, 2008).

From an agricultural point of view, the flow of plant nutrients in commonly used sanitation systems is predominantly linear where landfills and water bodies are the endpoints for the important agricultural nutrients: nitrogen, phosphorus, and potassium. These nutrients are taken up from the soil by the crops that are harvested, then transported, eaten, excreted, and finally discharged. Conventionally, the loss of the most important macronutrients has been partly compensated through application of synthetic fertilizers. However, the production of the most important and commonly used synthetic fertilizer ingredients - nitrogen, phosphorus, and potassium - relies on non-renewable resources and its supply is finite. Synthetic fertilizer prices are continuously increasing and often not an affordable solution for many farmers. Hence, a more reuse-oriented approach to sanitation can help to significantly improve the food security situation in the country and to return urgently needed nutrient resources to the field instead of discharging them into the environment.

-

- ▶ Philippines Environment Monitor (2003): Water Quality. Manila, World Bank, available online: [http://www.wds.worldbank.org/external/default/WDSCContentServer/WDSP/IB/2004/05/24/000012009\\_20040524135608/Rendered/PDF/282970PH0Environment0monitor.pdf](http://www.wds.worldbank.org/external/default/WDSCContentServer/WDSP/IB/2004/05/24/000012009_20040524135608/Rendered/PDF/282970PH0Environment0monitor.pdf)
- ▶ WHO/UNICEF (2008): Joint Monitoring Report for Water Supply and Sanitation - Estimates for the use of Improved Sanitation Facilities - Philippines. Updated March 2010, World Health Organization and United Nations Children's Fund, available online: <http://www.wssinfo.org/datamining/graphs.html>
- ▶ WSP-EAP (2008): Economic impacts of sanitation in the Philippines, Water and Sanitation Program - East Asia and the Pacific, World Bank and USAID, Manila, Philippines, available online: [http://www.wsp.org/wsp/sites/wsp.org/files/publications/529200894452\\_ESI\\_Long\\_Report\\_Philippines.pdf](http://www.wsp.org/wsp/sites/wsp.org/files/publications/529200894452_ESI_Long_Report_Philippines.pdf)



## introduction to sustainable sanitation

The term sanitation refers to the hygienic and proper management, collection, disposal/reuse of human excreta (feces and urine) and domestic wastewater to safeguard the health of individuals and communities. This is usually concerned with preventing diseases by hindering pathogens or disease-causing organisms found in excreta and wastewater from entering the environment and coming into contact with people and communities. This also involves the construction of adequate collection and disposal/reuse facilities and the promotion of proper hygiene behavior so that facilities are effectively used at all times (DOH, 2010a).

However, in order for a sanitation system to be sustainable, it should not only protect and promote human health but should also aim to minimize environmental degradation and depletion of the resource base, while being technically and institutionally appropriate and maintaining social acceptability and economic viability in the long run.

The recently published Philippine Sustainable Sanitation Roadmap builds on 10 guiding principles that respond to the direction of sustainable sanitation:

1. Sanitation is a human right, a social and economic good.
2. Sanitation is essential for basic health and dignity of the person.
3. Sanitation policies, plans, and programs must be localized and its management decentralized at the lowest level possible.
4. Sanitation is everybody's business and different stakeholders must be involved in promoting good sanitation and hygiene practices.
5. Sanitation systems must be financially sustainable, economically affordable, and socially and culturally acceptable.
6. Good sanitation contributes to environmental sustainability and penalizes polluters.
7. Sanitation services must be demand responsive. This includes consideration of appropriate technology and management options at various levels.
8. Proper resource conservation, reuse, recycle, and recovery of sanitation byproducts will be considered.
9. Access to sanitation should be equitable and sensitive to gender differences.
10. Efficient water governance includes sanitation (DOH, 2010b).

The Sustainable Sanitation Alliance (SuSanA) recommends in its vision document that certain sustainability criteria should be considered when improving an existing and/or designing a new sanitation system. The following are the criteria:

1. Health and hygiene: includes the risk of exposure to pathogens and hazardous substances that could affect public health at all points of the sanitation system from the toilet via the collection and treatment system to the point of reuse or disposal and downstream populations. It also covers aspects such as hygiene,

nutrition and improvement of livelihood achieved by the application of a certain sanitation system, as well as downstream effects.

2. Environment and natural resources: involves the required energy, water and other natural resources for construction, operation and maintenance of the system, as well as potential emissions to the environment. It also includes the degree of recycling and reuse practiced and the effects of these (e.g. returning nutrients and organic material to agriculture), and the protection of other non-renewable resources, e.g. through the production of renewable energies (e.g. biogas).
3. Technology and operation: incorporates the functionality and the ease with which the entire system including the collection, transport, treatment and reuse and/or final disposal can be constructed, operated and monitored by the local community and/or the technical teams of the local utilities. Furthermore, the robustness of the system, its vulnerability towards power cuts, water shortages, floods, earthquakes, and the flexibility and adaptability of its technical elements to the existing infrastructure and to demographic and socio-economic developments are important aspects.
4. Financial and economic issues: relate to the capacity of households and communities to pay for sanitation including the construction, operation, maintenance and necessary reinvestments in the system. Besides the evaluation of these direct costs, direct benefits from recycled products (soil conditioner, fertilizer, energy and reclaimed water) and external costs and benefits have to be taken into account. Such external costs are environmental pollution and health hazards, while benefits include increased agricultural productivity and subsistence economy, employment creation, improved health, and reduced environmental risks.
5. Socio-cultural and institutional aspects: refer to the socio-cultural acceptance and appropriateness of the system, convenience, system perceptions, gender issues and impacts on human dignity, the contribution to food security, compliance with the legal framework, and stable and efficient institutional settings (SuSanA, 2008).

The different low-cost arborloo and urine diversion toilets described in this manual are often referred to as ecosan (ecological sanitation) solutions. The term 'ecosan' describes reuse-oriented sanitation solutions that recognize human excreta and water from households not as waste but as resources that have to be recovered, treated where necessary, and safely reused. Ecosan solutions represent some of the possible solutions under the wider sustainable sanitation umbrella.

The technologies described have been successfully introduced in many areas all over the Philippines. However, as stated above, their appropriateness in a specific local context is not only dependent on the technological feasibility and affordability but also on many other components like the social acceptability of the resource reuse and the implied behavior change. All these aspects need to be thoroughly considered before implementing these sanitation technologies.

- ▶ DOH (2010a): Administrative Order 2010-0021 – Sustainable Sanitation as a National Policy & National Priority Program of the DOH. Department of Health, Republic of the Philippines
- ▶ DOH (2010b): Philippine Sustainable Sanitation Sector Roadmap, Department of Health, Manila, Philippines
- ▶ SUSANA (2008): Towards more sustainable sanitation solutions, Sustainable Sanitation Alliance vision document, version 1.2, February 2008

## low-cost sustainable sanitation technologies

### the arborloo toilet

Literally known as “tree toilet,” the arborloo is a shallow pit latrine that is filled over time with human excreta. After each use, a cup of ash or soil is dumped into the pit to cover the excreta and as soon as the pit is filled up, the cover slab and the superstructure can be transferred to a new area while a tree (e.g. fruit trees like banana or mango trees) can be planted on top of the nutrient-rich substrate of the old pit. The arborloo - originally developed by Peter Morgan in Zimbabwe - is a variation of a pit latrine only that the cover slab, the toilet bowl, and the superstructure are transferable when the pit is filled up.

The cover slab can be made out of concrete or of wood poles with wood/bamboo flooring. The wooden cover slab is less durable but lightweight and easier to carry (2-3 persons can easily carry it), while the concrete slab is more durable but needs around 6-8 people to transfer it when the pit is full. For the superstructure, a variety of construction material options exists depending on what is locally available, for instance, banana leaves, recycled sacks, wood, and nipa.

The arborloo can be used with or without urine diversion system. The advantage of a separate urine collection is that the nutrient-rich urine can be used directly as a liquid fertilizer in agricultural production and potential groundwater contamination caused by urine infiltration in the soil can be avoided. This requires a urine diversion toilet bowl (see UDDT chapter) and a separate container for the urine collection that can be placed below ground outside the toilet structure (see schematic below). In addition, a urinal made out of used plastic containers (see the ecopee chapter) can be placed inside or outside the toilet.

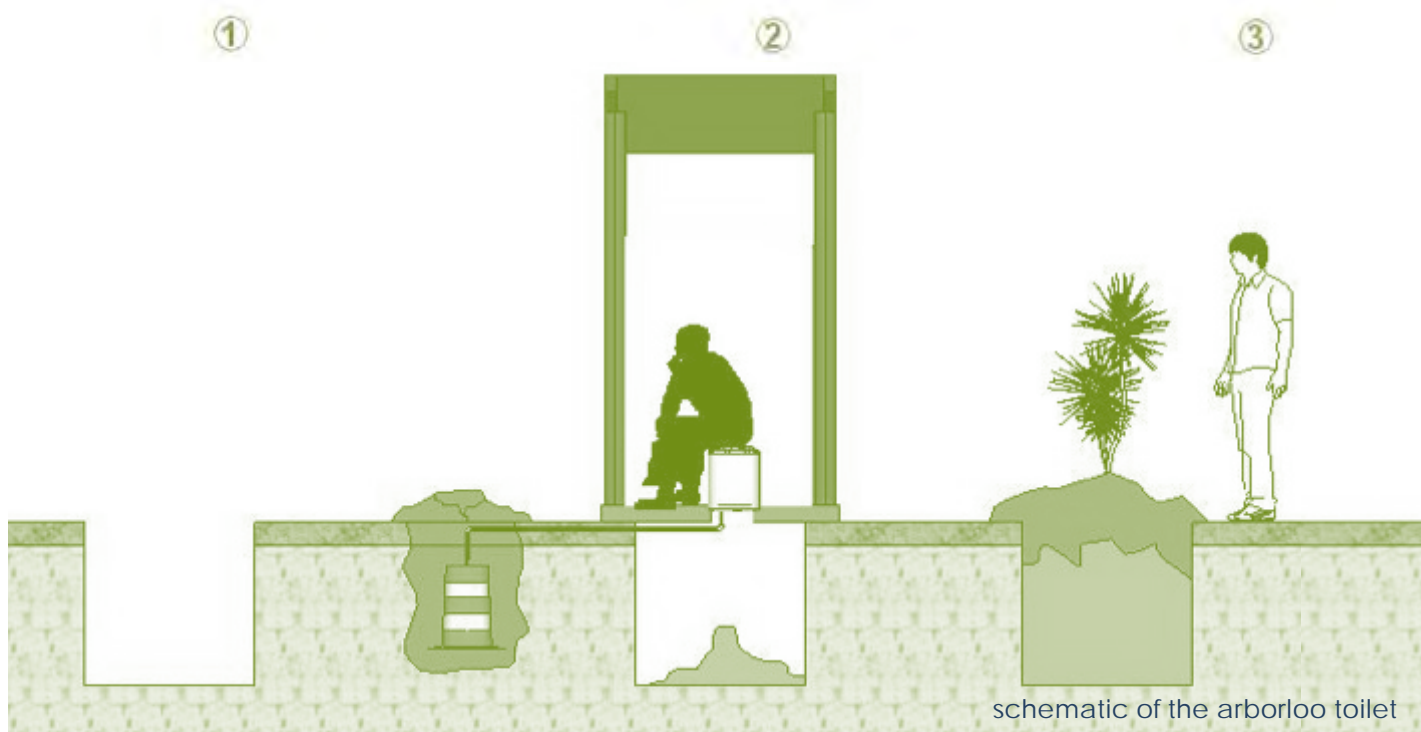

schematic of the arborloo toilet



simple arborloo toilet with concrete cover slab & concrete bowl in a mountainous area of Misamis Oriental



arborloo toilet with bamboo & banana leaf superstructure & EcoPee urinal for separate urine collection



Interior of the arborloo  
(concrete floor, container for covering material & EcoPee urinal)



arborloo toilet



## operation and maintenance

The toilet should always be kept clean. Rubbish materials such as plastics, cans and rags should not be put into the pit. The toilet bowl should always be covered to avoid breeding of flies and to prevent access of vermin such as mice or cockroaches. "First time" users should be briefed on the appropriate use and/or "user's guidelines" should be placed inside the toilet for those persons who are not familiar with arborloo (or a urine diversion toilet bowl). After defecating, the feces should be covered with ash or soil to hasten the drying process and to prevent unpleasant odor. An ample supply of covering material must always be available. No water should enter the pit during rainy season. Furthermore, a handwashing facility with soap close to the toilet should always be available. Handwashing with soap is one of the most effective preventative measures/ barriers against waterborne diseases such as diarrhea.

## reuse/safe disposal options

When the pit is full, it must be covered with soil and other organic materials and (fruit) trees can be planted on top of it, making use of the nutrient- and organic matter-rich substrate of the pit. Since there is no direct contact between the fruits of the trees and the material in the pit, the potential fruit production can be considered safe for consumption. If urine is collected separately, it can be used as liquid fertilizer in agricultural production. Urine is a well-balanced nitrogen-rich, quick-acting fertilizer that can help boost agricultural production. The health risks associated with the use of urine are generally low. Urine is an almost sterile medium. However, in order to reduce the possible health risks to a minimum, it is recommended that the urine should be stored for at least one month (WHO, 2006) before it can be considered safe for agricultural reuse. For detailed information on the use of urine, please see the SEI 2010 publication 'Practical Guidance on the Use of Urine in Crop Production.'

## adequacy

Since the arborloo toilet is a pit latrine with a relatively high risk of pathogenic groundwater contamination, it is important to consider the depth of the local groundwater table when implementing the arborloo. Arborloo toilets are, therefore, more appropriate in mountainous areas with a low groundwater table. Building it in coastal areas or near rivers is not recommended since the water level is usually high, making the contamination of groundwater highly possible.

An arborloo toilet is an adequate solution in areas with (temporary) water scarcity since it is a dry sanitation solution and enough space should be available to continuously re-dig and re-fill pits.

-

- ▶ WHO (2006): Guidelines for the Safe Use of Wastewater, Excreta and Greywater: Vols 1-4. Geneva: World Health Organisation (WHO)

## materials needed and estimated costs per unit (as of 09/2010)

BASIC MATERIALS				
Quantity	Unit	Item	Cost/Unit (PhP)	Subtotal (PhP)
50	bd ft	2' x 2' x 8' Coco Lumber	14.00	700.00
19	bd ft	4' x 4' x 8' Coco Lumber	14.00	266.00
2	kilos	4" Common Wire Nail	44.00	88.00
1.5	kilos	3" Common Wire Nail	46.00	69.00
0.5	kilos	1" Common Wire Nail	52.00	26.00
2	pcs	2" x 3" Door Hinge	15.00	30.00
1	pc	Door Pull	15.00	15.00
1	pc	1" PVC 90° Elbow	22.00	22.00
2	m	1" Polyethylene Pipe	23.00	46.00
1	m <sup>3</sup>	Excavation	120.00	120.00
2	bundles	1" Bamboo Strips	60.00	120.00
30	pcs	Nipa Shingles	5.00	150.00
2	unit	Plastic Container	60.00	120.00
1	unit	Concrete UDDT Bowl	200.00	200.00
			<b>Total</b>	<b>1,972.00</b>

## ADDITIONAL MATERIAL OPTIONS

(the respective costs for wall and cover slab need to be added to the basic material costs)

1. Option for the Wall: Amakan/Landay				
Quantity	Unit	Item	Cost/Unit (PhP)	Subtotal (PhP)
4	pcs	Landay Sacks	12.00	48.00
2	sheets	Bamboo Mat (Amakan)	120.00	240.00
			<b>Total</b>	<b>288.00</b>
2. Option for the Wall: Landay Wall				
Quantity	Unit	Item	Cost/Unit (PhP)	Subtotal (PhP)
16	pcs	Landay Sacks	12.00	192.00
			<b>Total</b>	<b>192.00</b>
3. Option for the Wall: Recycled Plastic Wall				
Quantity	Unit	Item	Cost/Unit (PhP)	Subtotal (PhP)
4	pcs	Recycled Plastic	60.00	240.00
			<b>Total</b>	<b>240.00</b>
1. Option for the Cover Slap: Concrete				
Quantity	Unit	Item	Cost/Unit (PhP)	Subtotal (PhP)
2	bag	Portland Cement	215.00	430.00
			<b>Total</b>	<b>430.00</b>
2. Option for the Cover Slap: Wood and Bamboo				
Quantity	Unit	Item	Cost/Unit (PhP)	Subtotal (PhP)
5	bd ft	4" x 4" x 8' Coco Lumber	14.00	0.00
4	bundle	Bamboo strips	60.00	240.00
			<b>Total</b>	<b>310.00</b>

- the figures above do not reflect labor costs
- the estimated costs are indicative and might vary in different areas and over time
- US\$ 1 = PhP 43.22 (as of 10/2010)





1 production of simple concrete arborloo bowls



2 production of concrete type UD toilet bowls as an alternative solution (alternatively, the more costly ceramic UD bowls can be ordered from CAPS)



3 producing a concrete cover slab with simple toilet bowl (cover slab can alternatively be made out of wood and bamboo, see next page)



4 digging a pit hole



5 setting of the wooden cover slab (including a urine diverting pipe)



6 extra hole for urine container if UD system is applied



7 building of superstructure (starting with the poles)



building of superstructure (setting up the walls)



7 building superstructure (setting up a door)



building superstructure (setting up a roofing)



8 placing the painted concrete toilet bowl

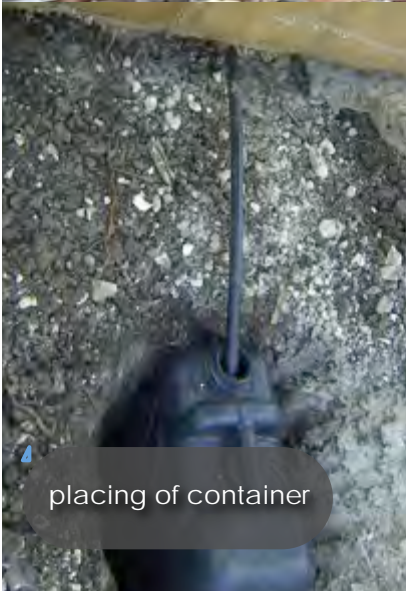

placing of container

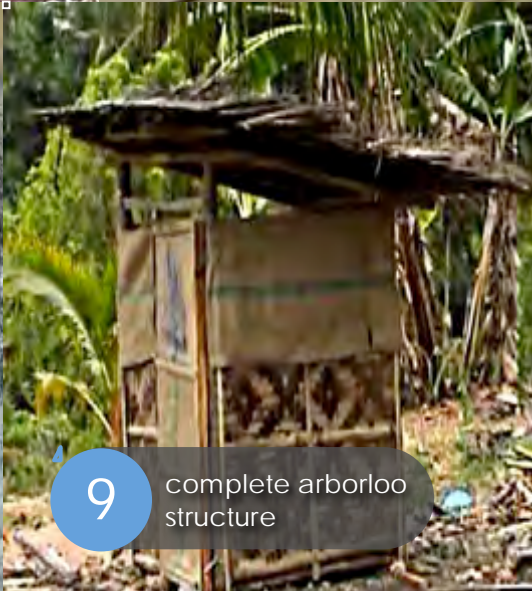

9 complete arborloo structure



happy user

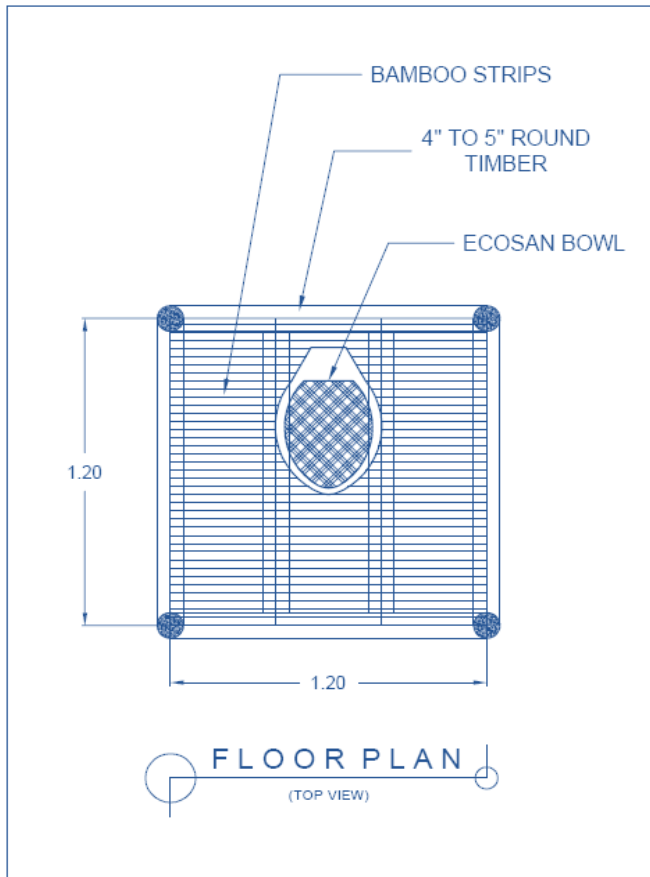

	TITLE: ARBOLOO	SHEET NO: 1
	SCALE: 1 : 20	11

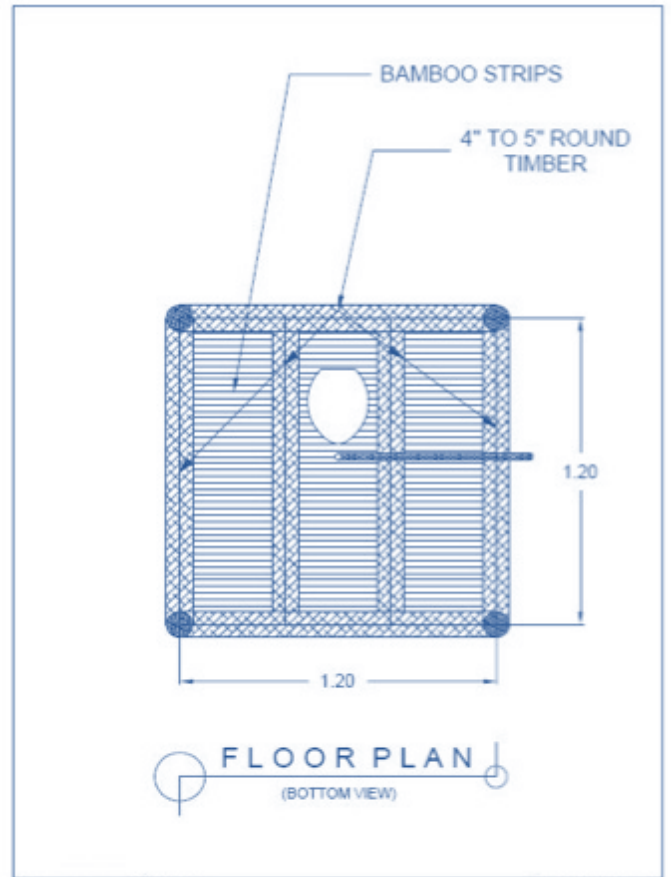

	TITLE: ARBOLOO	SHEET NO: 2
	SCALE: 1 : 20	11

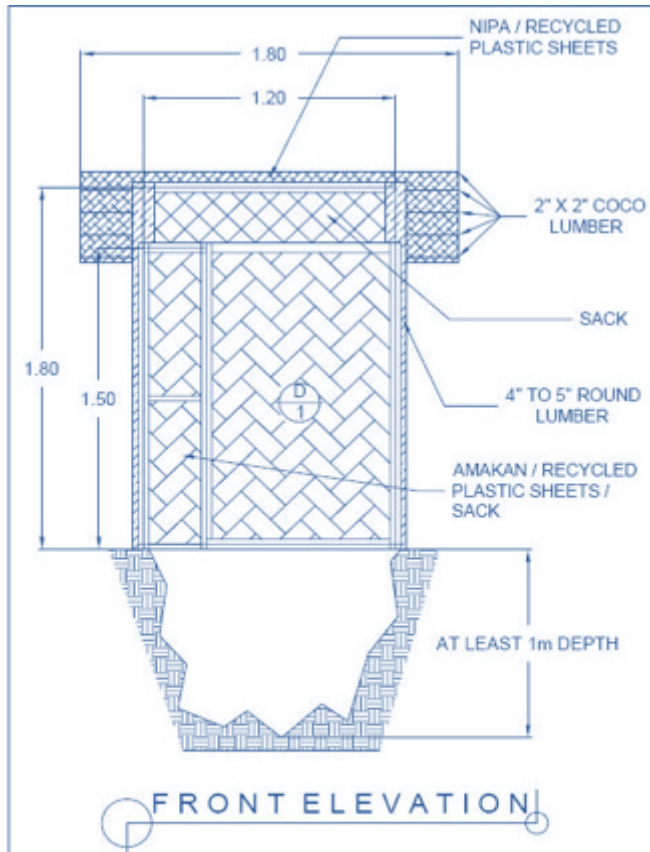

	TITLE: ARBOLOO	SHEET NO: 3
	SCALE: 1 : 25	11

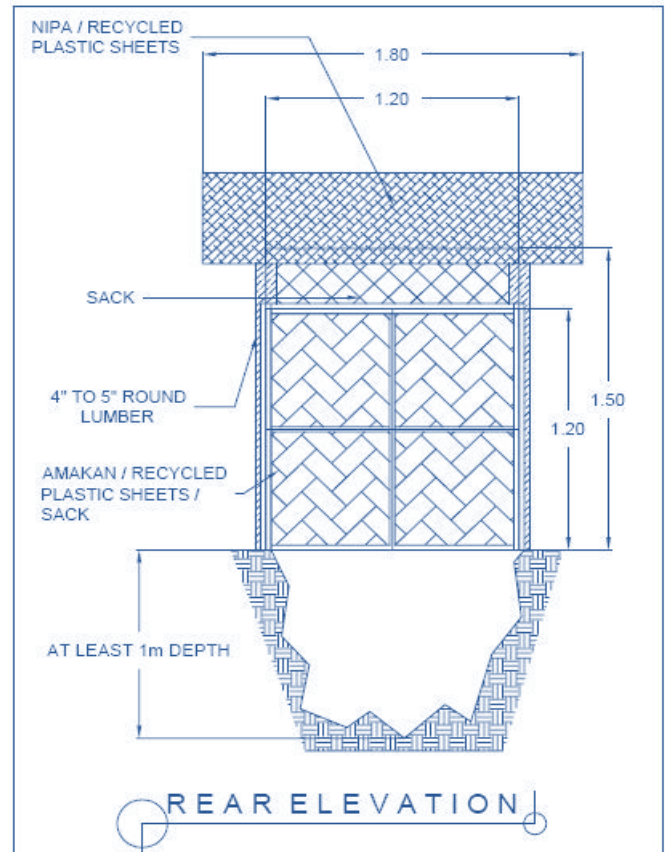

	TITLE: ARBOLOO	SHEET NO: 4
	SCALE: 1 : 25	11

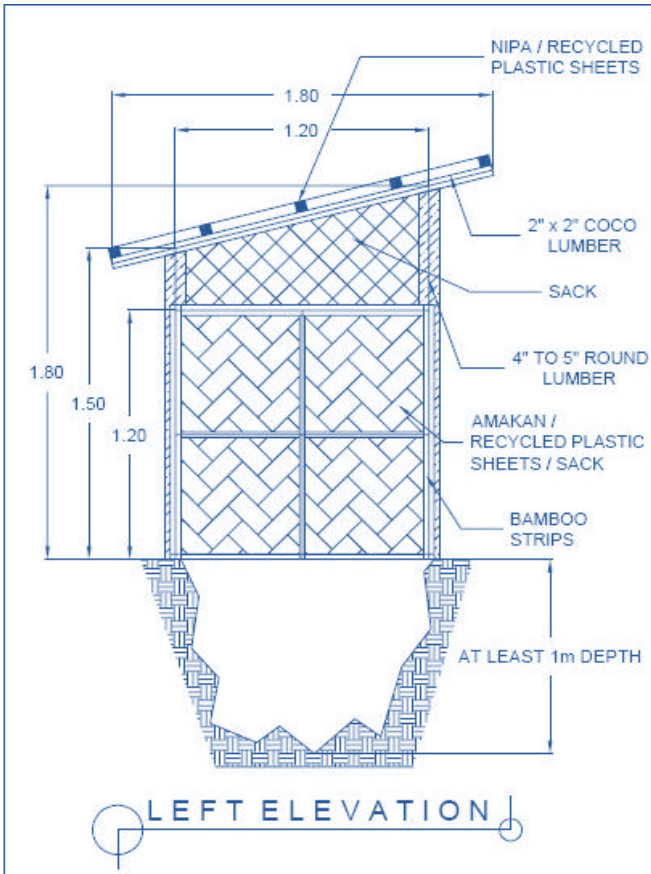

	TITLE:	ARBOLOO	SHEET NO:	<b>5</b> 11
	SCALE:	1 : 25		

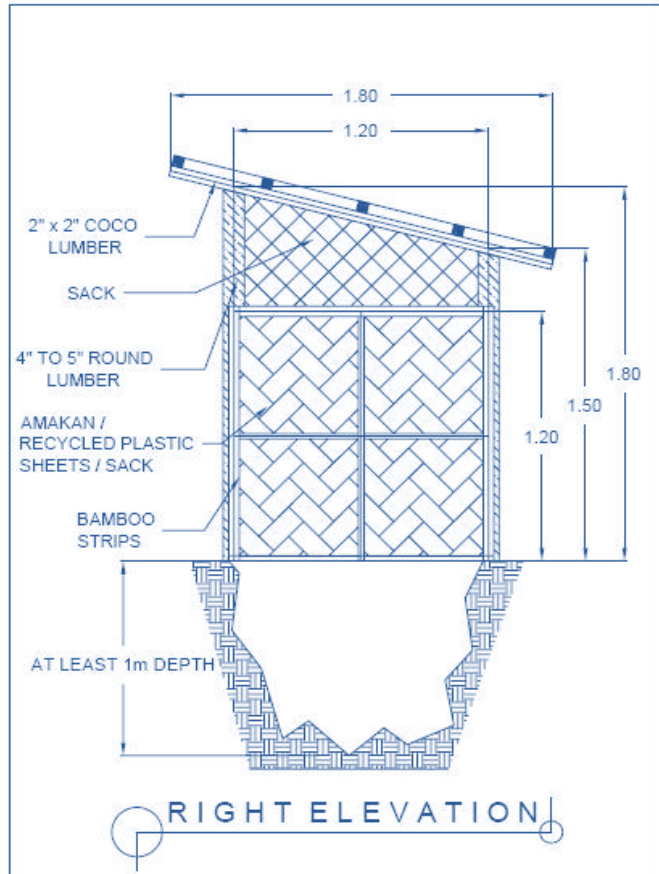

	TITLE:	ARBOLOO	SHEET NO:	<b>6</b> 11
	SCALE:	1 : 25		

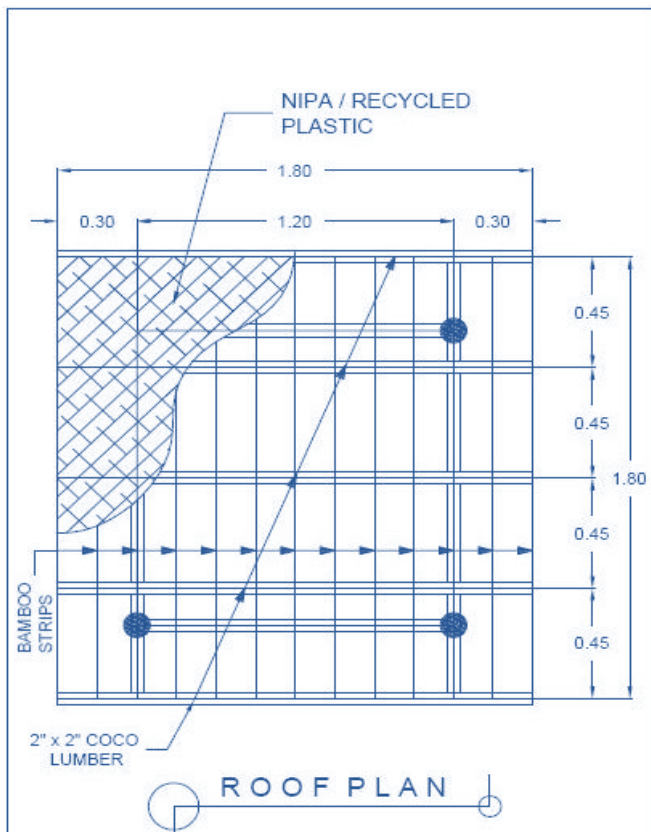

	TITLE:	ARBOLOO	SHEET NO:	<b>7</b> 11
	SCALE:	1 : 20		

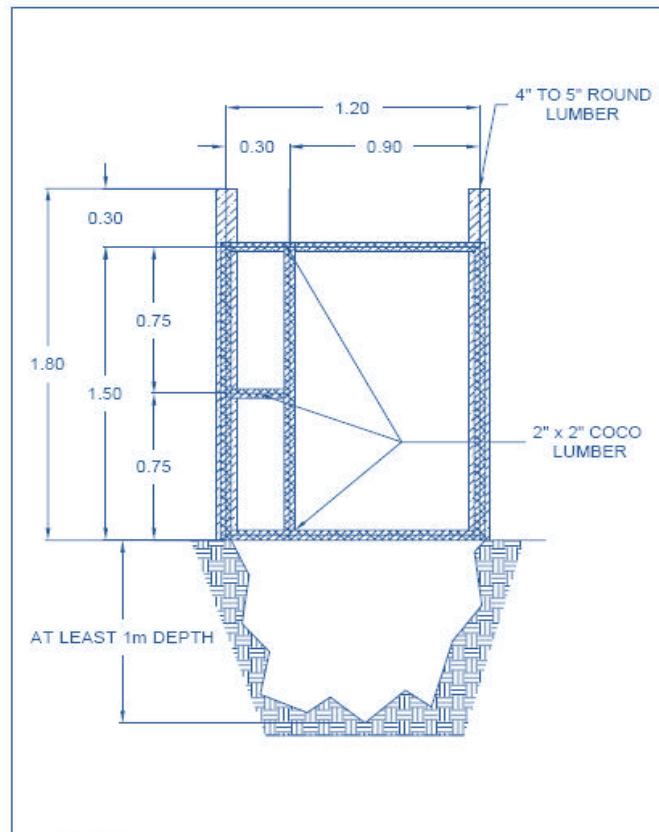

	TITLE:	ARBOLOO	SHEET NO:	<b>8</b> 11
	SCALE:	1 : 25		

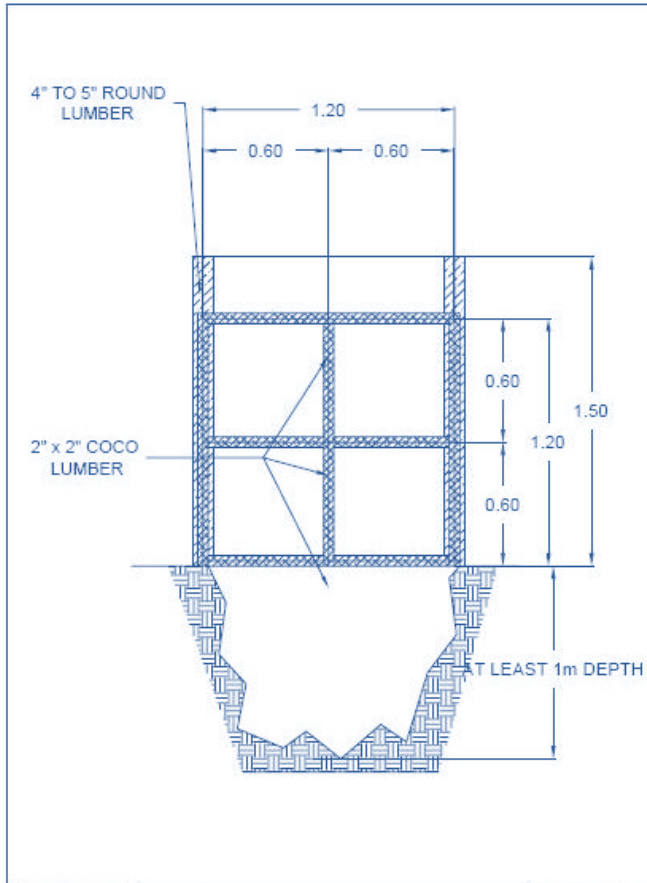

	TITLE: ARBOLOO	SHEET NO:
	SCALE: 1 : 25	9 / 11

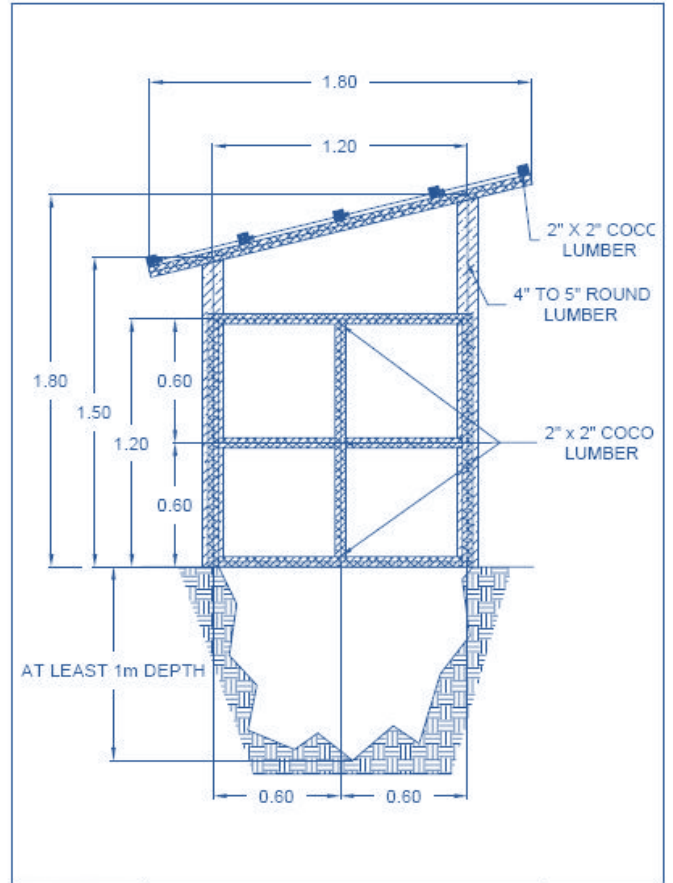

	TITLE: ARBOLOO	SHEET NO:
	SCALE: 1 : 20	10 / 11

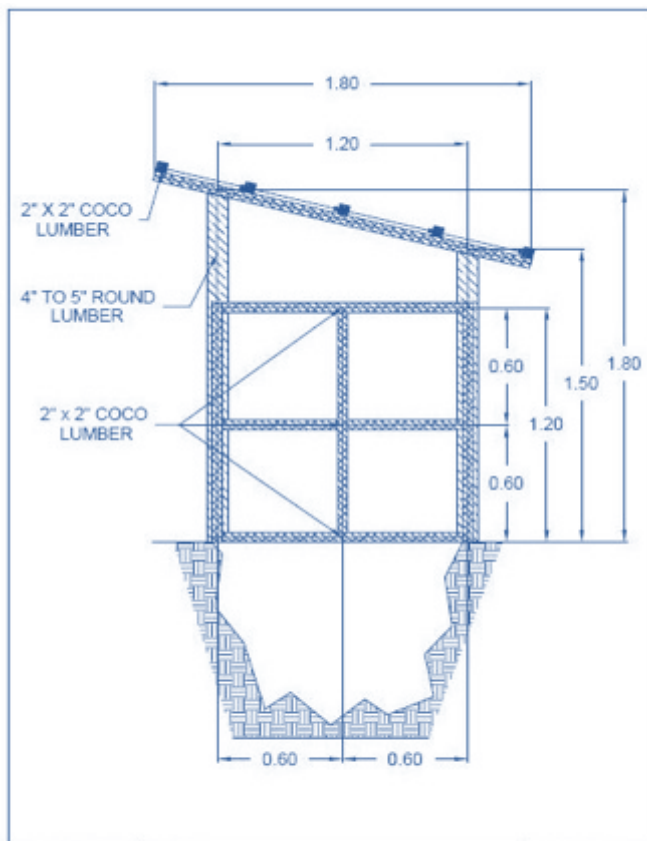

	TITLE: ARBOLOO	SHEET NO:
	SCALE: 1 : 20	11 / 11

## low-cost sustainable sanitation technologies

### the one-chamber UDDT

The functional idea of the 1-chamber urine diversion dehydration toilet (UDDT) is similar to a 2-chamber toilet. Having only one collection chamber reduces the cost of construction material, but it impacts collection and storage. Following are the primary principles: Urine and feces are collected separately. Urine goes directly into a container or jerrican while the feces are collected in a separate chamber and dried, aided by heat, ventilation and addition of bulking agents. However, unlike double vault toilets, single vault systems do not offer the possibility of prolonged storage of excreta within the sealed vault, and the collected fecal material needs to be regularly collected and appropriately treated.

The one-chamber UDDT can be made out of different local materials such as bamboo, plywood, recycled sacks, nipa or concrete, depending on their availability and the budget. Concrete single-vault UDDTs should have an anal and hand washing area as part of the design, while the low-cost single-vault UDDTs usually have no anal and hand washing area inside the toilet since most users are wipers. However, separate hand washing areas are always recommended outside the toilet. Drying materials such as ash from burnt firewood (used for cooking) or carbonized rice hull may be used to cover the feces to enhance the treatment process. The feces storage compartment is usually made of rattan baskets or recycled steel drums cut in half, lined with a plastic sack for easier collection, handling, and transport. Recycled plastic containers may be used as urine collectors. If money is not a constraint, it is always recommended to use the more expensive ceramic urine diversion (UD) toilet bowls (can be ordered from CAPS, see contact details at the end of the manual), otherwise, the toilet bowls can be locally made out of concrete. The concrete-type bowls are a lot cheaper to produce and can easily be made locally but might cause smell problems in the long term. Specialized urine-diverting squatting pans (reinforced with plastic sheet to prevent urine spillage) are also available.

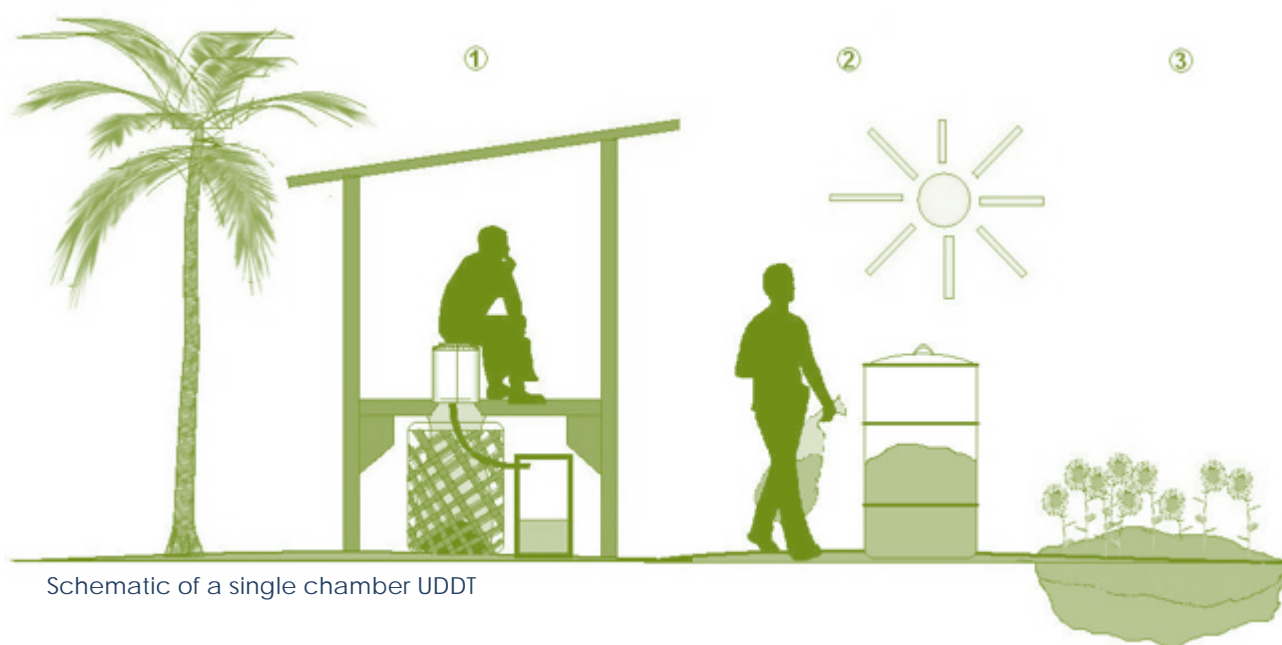

Schematic of a single chamber UDDT



low-cost 1-chamber UDDT  
(with amakan walls and nipa roof)



interior of the 1-chamber UDDT  
(superstructure made out of wood & recycled sacks)



construction of 1-chamber UDDT attached to a house  
(allows to save on material costs for one wall)







1-chamber UDDT using wood and recycled plastic for the walls

one-chamber UDDT



Interior of the 1-chamber UDDT  
(bamboo flooring, concrete UD bowl and bucket for drying material and toilet paper)



collection compartment underneath the toilet  
(including basket with sack lined with plastic bag for feces collection & urine collection container)

## operation and maintenance

When defecating, the user should make sure that urine and feces are separated so that no fecal material enters the urine compartment and vice versa. After defecating, the feces should be covered with locally available drying materials such as lime/sawdust mixture or dried soil, ash, or rice hulls. Feces must be covered properly to hasten the drying process and to prevent the occurrence of unpleasant odor. Therefore, an ample supply of covering material must always be available. For people who are “wipers,” toilet papers should be placed in a separate trash bin and burned regularly, and not thrown into the feces chamber. For people who are “washers,” the separate anal washing area should be used. The lid of the UD bowl should always be closed to prevent flies from entering. The fecal chamber must always be kept completely dry, and users should aim to prevent water from entering the fecal chamber when cleaning the toilet. Water should not be poured on the floor since it may enter the fecal chamber. The UD bowl should be cleaned regularly either with a rag or a stick with a damp cloth. Water for anal and hand washing should always be available.

When the plastic sack inside the fecal storage compartment is full, it has to be removed and replaced with a new sack. The filled-up sacks should be sealed and stored close to the toilets until collection for further processing and reuse. After a relatively short storage time, urine can be directly used as a fertilizer in small-scale agricultural production or it may be stored close to the toilet until collected by a local service provider if such service exists locally. The collection and reuse aspect, as well as the potential need for a local service provider, needs to be considered in the planning right from the beginning.

In addition, first time users must be oriented on the appropriate use of the UDDT. Posters with the most important Do’s and Don’ts are available online in English and Cebuano and can be obtained from the SUSAN Center (see contact details at the end of the manual).



## reuse/safe disposal options

The WHO recommends that the collected urine should be stored for around 1 month before it can be safely reused in agriculture. This storage time increases the pH inside the container and kills all remaining pathogens. Urine can be considered a well-balanced nitrogen-rich, quick-acting liquid fertilizer since nutrients in urine are mostly water soluble, hence, are directly available for plant uptake. Urine is best utilized as a fertilizer for nitrogen-demanding crops such as corn and leafy vegetables. Urine can be applied either with or without dilution. When applying undiluted urine, water should be applied right after the application of urine. When diluted, the dilution ratio could be between 1:1 (1 part urine to 1 part water) to up to 1:10. Urine should be applied 10 cm away from the plants and immediately covered with soil to avoid loss of ammonia. Urine should not be sprayed on plants to avoid foliar burning. A waiting period of 1 month from the last urine application before harvest of crops should always be observed as an additional safety measure.

Pathogen concentration in feces is usually very high. Thus, for the safe reuse of feces in agriculture, it is critical that it has to be handled in such a way that the risk of disease transmission is minimized and the dried feces are appropriately treated. It is, therefore, recommended to store the feces for at least 10-12 months with subsequent aerobic composting (temperature of above 50°C should be achieved and maintained for a duration of at least 1 week in the compost heap) or vermicomposting (for at around 60 days) as a secondary treatment option before it can be considered safe for reuse as organic matter- and nutrient-rich compost. After secondary treatment has been completed, the processed feces can be used like any other organic fertilizer where nutrients are slowly released as they are degraded in the soil by microorganisms. Although initial research trials have shown a safe product after secondary treatment, it is recommended that treated feces should not be used for vegetables but for (fruit) trees only to ensure acceptance of the produce by customers and to further minimize health risks.

If there is no further reuse intention or low local acceptance for the feces reuse, the dried feces can also be buried (in areas where the groundwater table is low) and covered with soil.

## adequacy

The single chamber UDDT can be built in rural and urban areas as long as sufficient space is available. The design can be altered to suit the needs of specific populations (i.e. smaller for children, people who prefer to sit or to squat, etc.) or locations. They are appropriate for almost every climate. In addition, it is a suitable solution in areas where water is limited or scarce since it is a dry sanitation solution that requires water only for hand and anal washing.

The regular maintenance and the handling of dried feces and urine needed for this type of toilet may prove problematic in some circumstances and may affect the acceptance by some communities or groups of people. The introduction of the UDDT technology usually implies a change in the user's behavior and the long-term success depends much on proper use, operation, and maintenance. Longer lasting information and awareness campaigns as well as proper monitoring are essential when introducing UDDTs as a new sanitation technology. Experience has shown that acceptance is highest where there is a strong interest in saving water and in making use of the nutrients from excreta.

## materials needed and estimated costs per unit (as of 09/2010)

BASIC MATERIALS				
Quantity	Unit	Item	Cost/Unit (PhP)	Subtotal (PhP)
56	bd ft	2" x 2" x 8' Coco Lumber	14.00	784.00
19	bd ft	4" x 4" x 8' Coco Lumber	14.00	266.00
2.5	kilos	4" Common Wire Nail	44.00	110.00
2	kilos	3" Common Wire Nail	46.00	92.00
1	kilos	1" Common Wire Nail	52.00	52.00
2	m	1" Polyethylene Pipe	23.00	46.00
1	pc	1" PVC 90° Elbow	15.00	15.00
2	pcs	2" x 3" Door Hinge	15.00	30.00
1	pc	Door Pull	15.00	15.00
2	bundles	1" Bamboo Strips	60.00	120.00
1	unit	Concrete UDDT Bowl	200.00	200.00
3	pc	Garbage Bag (black)	15.00	15.00
30	pcs	Nipa Shingles	5.00	150.00
3	unit	Plastic Container	60.00	180.00
1	unit	Rattan Bukag	200.00	200.00
			Total	2,275.00

### ADDITIONAL MATERIAL OPTIONS FOR THE WALL

(the respective costs for the wall need to be added to the basic material costs)

Walls	1. Option: Amakan/Landay			
	Quantity	Unit	Item	Cost/Unit (PhP)
	8	pcs	Landay Sacks	12.00
	2	sheets	Bamboo Mat (Amakan)	120.00
				Total
2. Option: Landay				
Quantity	Unit	Item	Cost/Unit (PhP)	
21	pcs	Landay Sacks	12.00	
			Total	
3. Option: Recycled Plastic (from Nestle)				
Quantity	Unit	Item	Cost/Unit (PhP)	
3	pcs	Landay Sacks	12.00	
2	sheets	Recycled Plastic	60.00	
			Total	
4. Option: Plywood				
Quantity	Unit	Item	Cost/Unit (PhP)	
4	pcs	Plywood Wall	240.00	
			Total	

- the figures above do not reflect labor costs
- the estimated costs are indicative and might vary in different areas and over time
- US\$ 1 = PhP 43.22 (as of 10/2010)

## how to build



1 setting up of 4 poles



2 setting up of cover slab



3 making holes for feces & urine compartment on the cover slab



4 placing the toilet bowl

# how to build

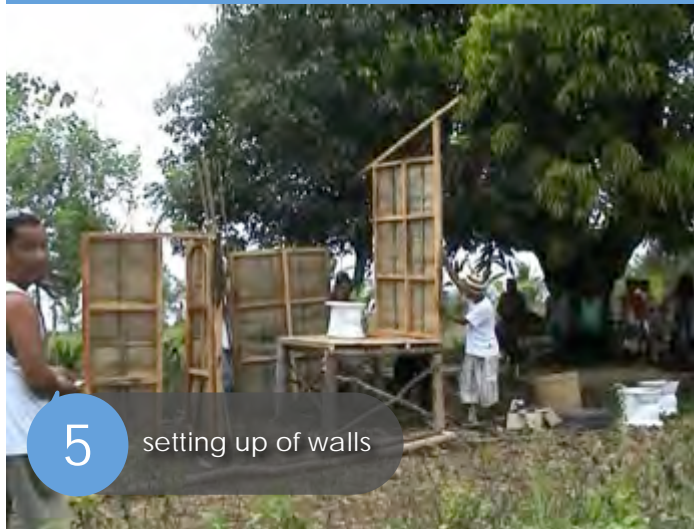

5 setting up of walls



6 setting up of roofing

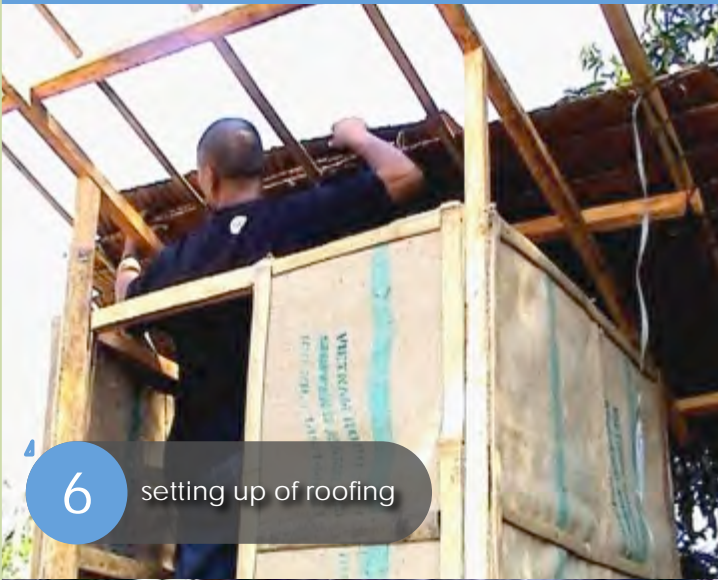

6

setting up of roofing



7

setting of feces & urine collector



8

complete structure of single chamber UDDT



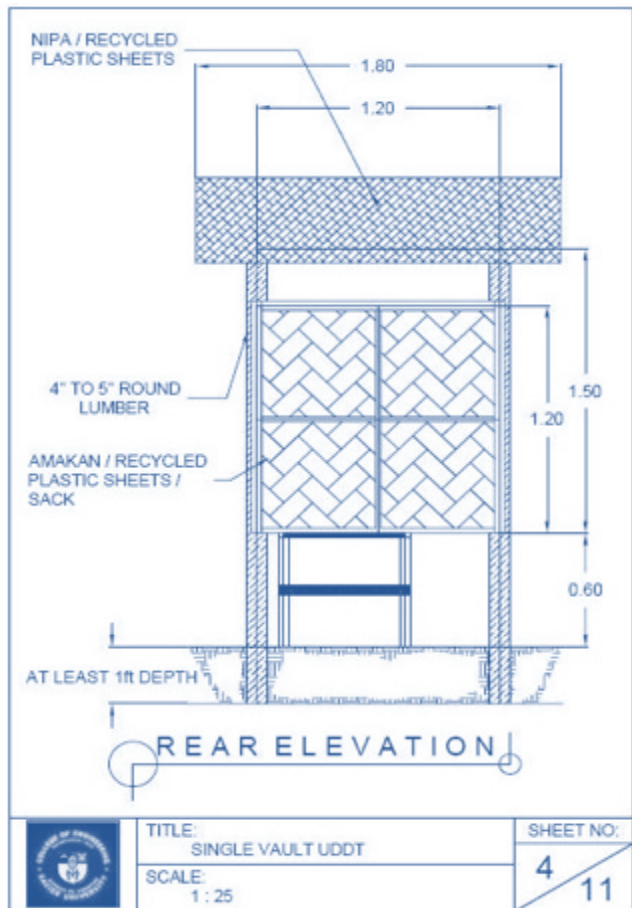
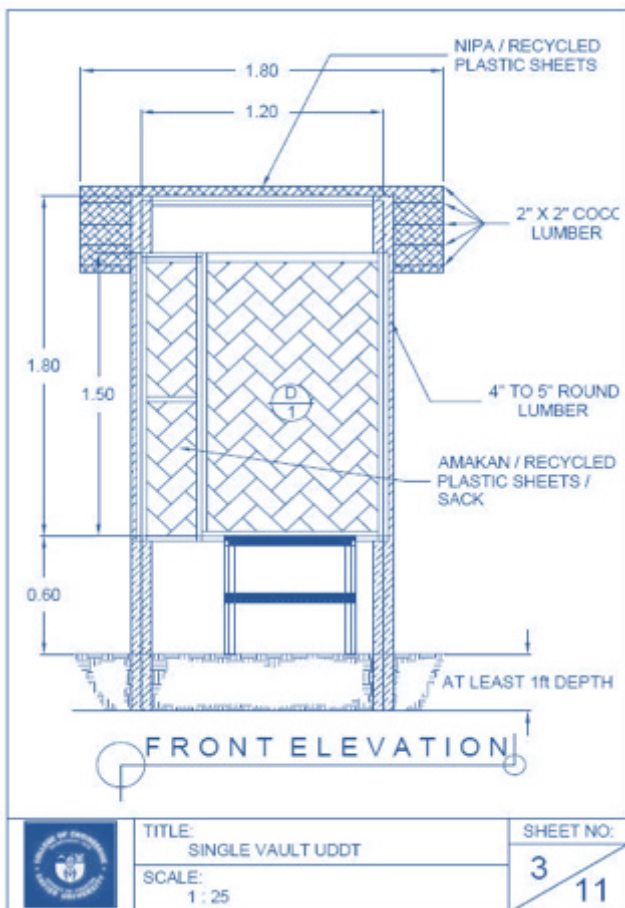
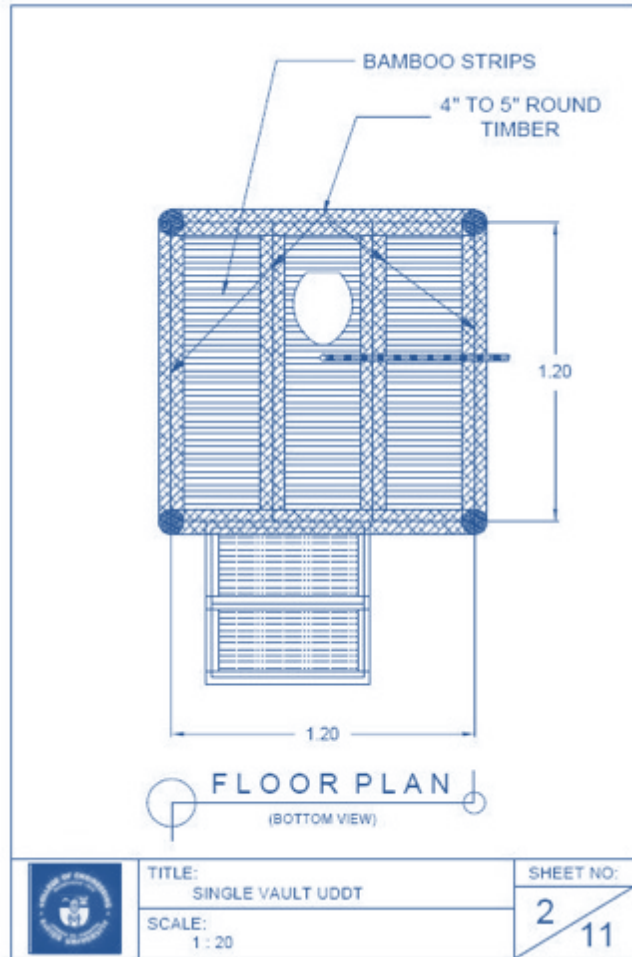
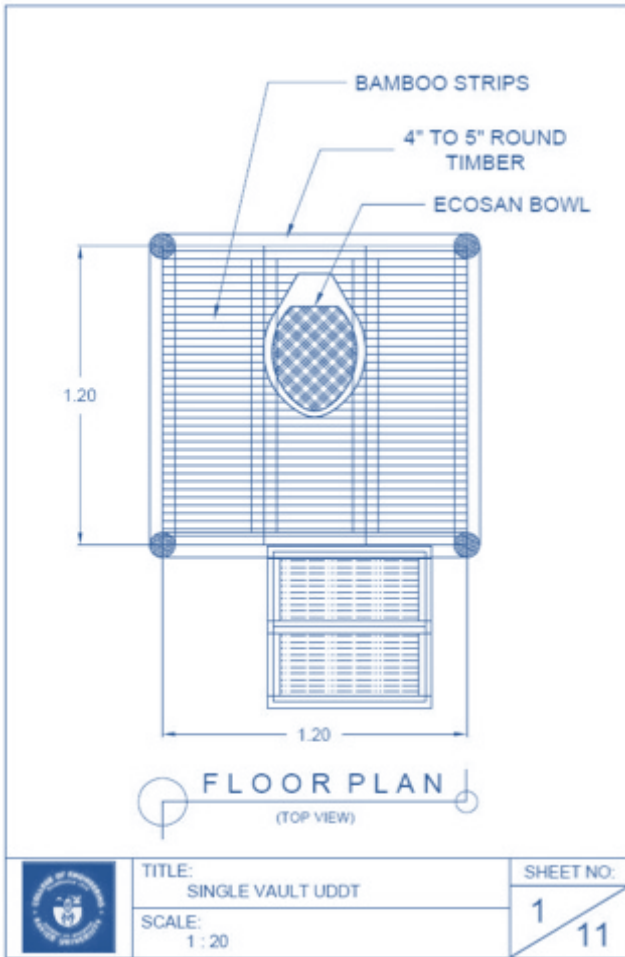

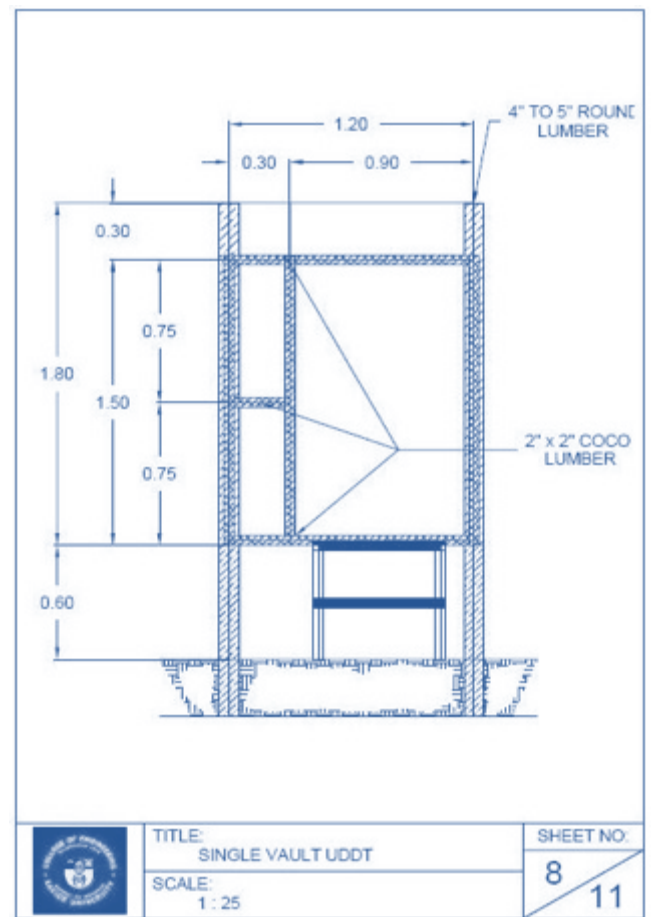
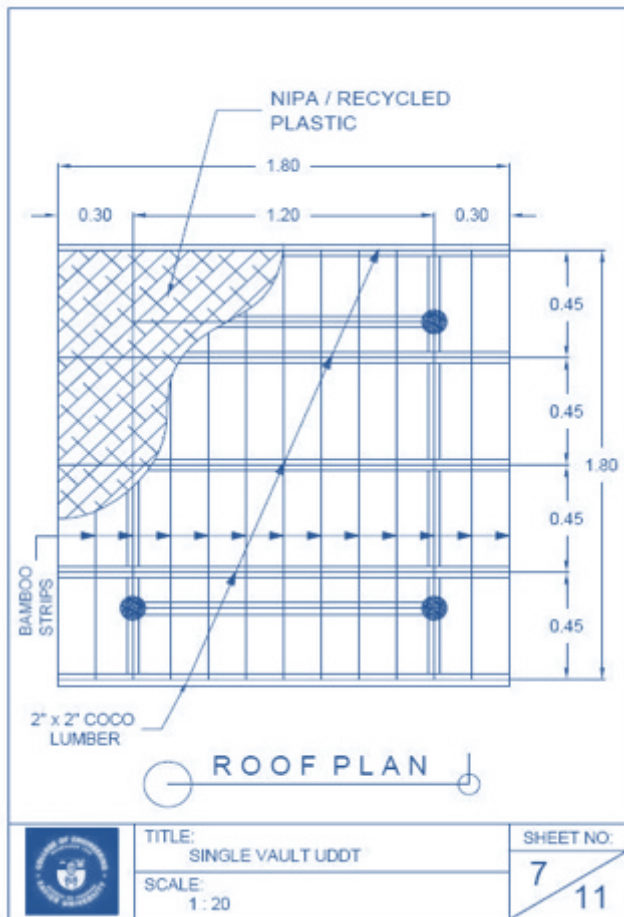
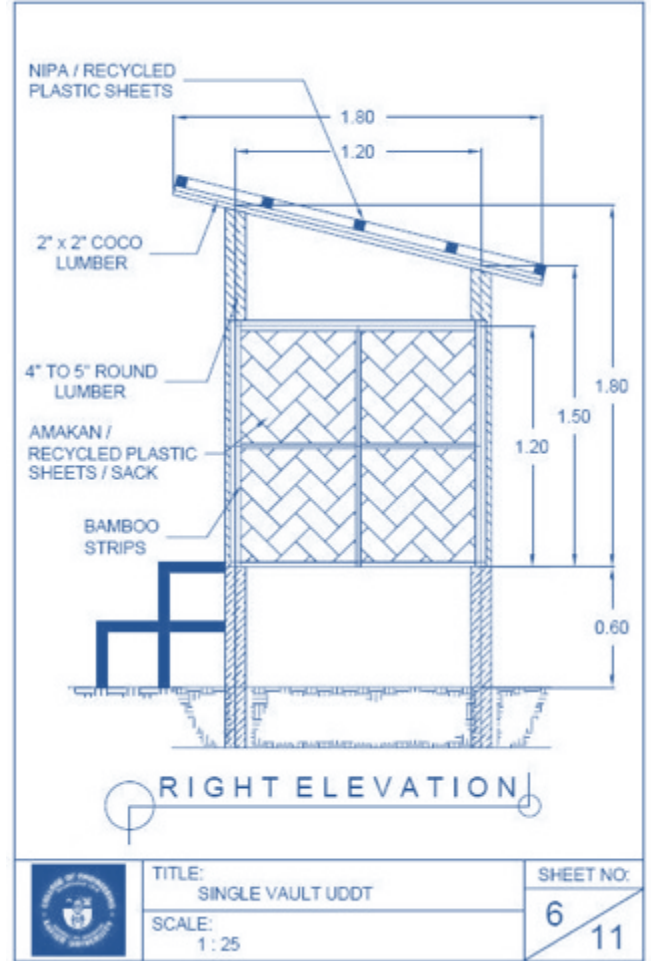
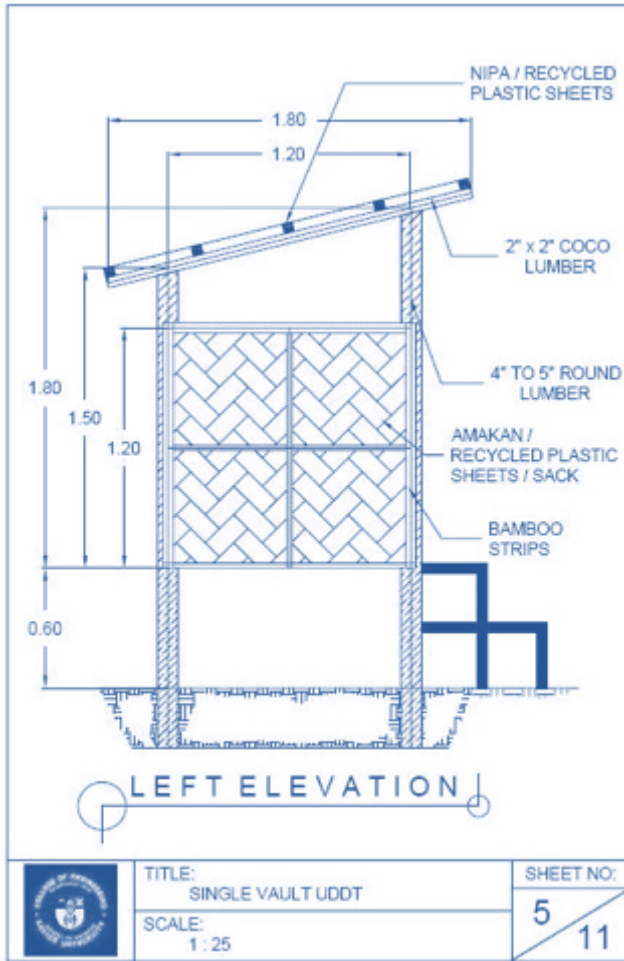

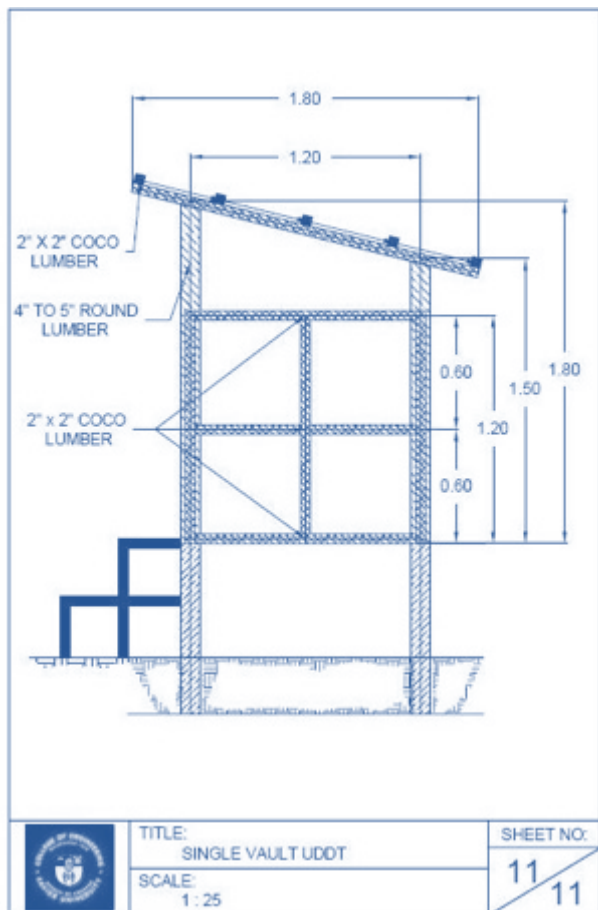
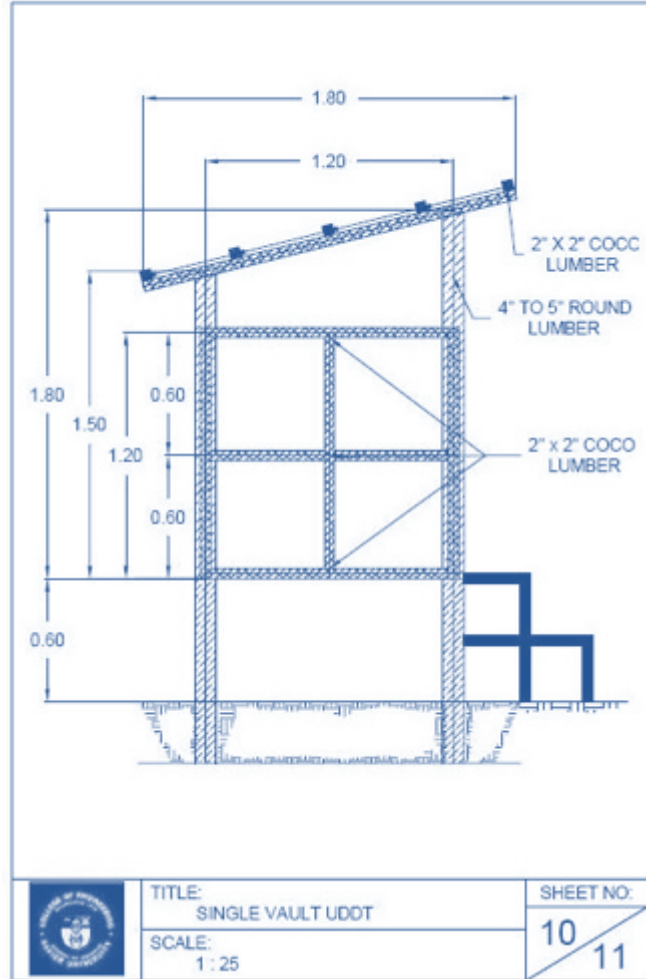
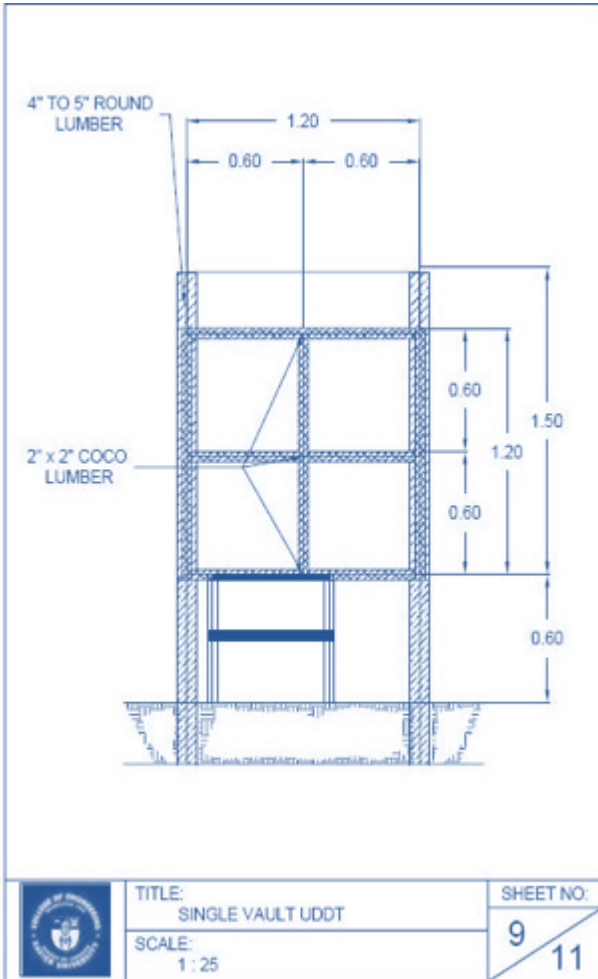

## concrete UD bowl construction



toilet bowl construction:  
filling of concrete into prefabricated moulds



cost per unit  
(as of 2010)

around 200 PhP  
(labor not included)



final removal of the moulds  
(moulds can be ordered from WAND)

## ceramic UD bowls

one-chamber UDDT



price list  
(as of 2010)

seat type:

- <30: 1,295.00 PhP
- 30-64: 1,195.00 PhP
- 65-129: 1,095.00 PhP
- >130: 995.00 PhP

bench type:

- <30: 774.00 PhP
- 30-64: 714.00 PhP
- 65-129: 654.00 PhP
- >130: 595.00 PhP



bench type ceramic UD bowl



seat type ceramic UD bowl  
(can be ordered from CAPS, see contact details at the end)

## low-cost sustainable sanitation technologies

### the two-chamber UDDT

The overall design of the 2-chamber UDDT is similar to the 1-chamber UDDT, except that there are 2 separate chambers for the collection and storage of feces. The primary functioning principles are similar. Urine and feces are diverted using a UD toilet bowl or UD squatting pan and are then collected separately. Urine goes directly into a container or jerrican, while the feces are collected in two vaults underneath the toilet seat or squatting pan, where they are stored and dried. A ventilation pipe connected to the vault helps to reduce odors and enhances the drying process. The urine is diverted by specially designed urine diversion toilet bowls or UD squatting pans. Anal cleansing water may be diverted through a separate funnel into an evaporation bed. Vaults are used alternately with only one vault in use at a time, until it is almost full. Ash, lime or a bulking agent should be added after each defecation to maintain high alkalinity and to absorb humidity. When this first vault is full, the defecation hole is sealed and the toilet bowl is transferred to the second vault. The second vault is now active while the first is passive or "maturing." When the second vault is full, the dried material can be removed from the first. The final dried fecal product has a sandy appearance and is generally odor free.

The 2-chamber UDDTs usually have a concrete substructure, which is relatively costly while the material for the superstructure can vary depending on the available local materials. Common materials for the superstructure are wood, bamboo, nipa or corrugated iron. The UDDT is usually equipped with a separate urinal, which is also connected to the urine container, and a facility for anal and hand washing.

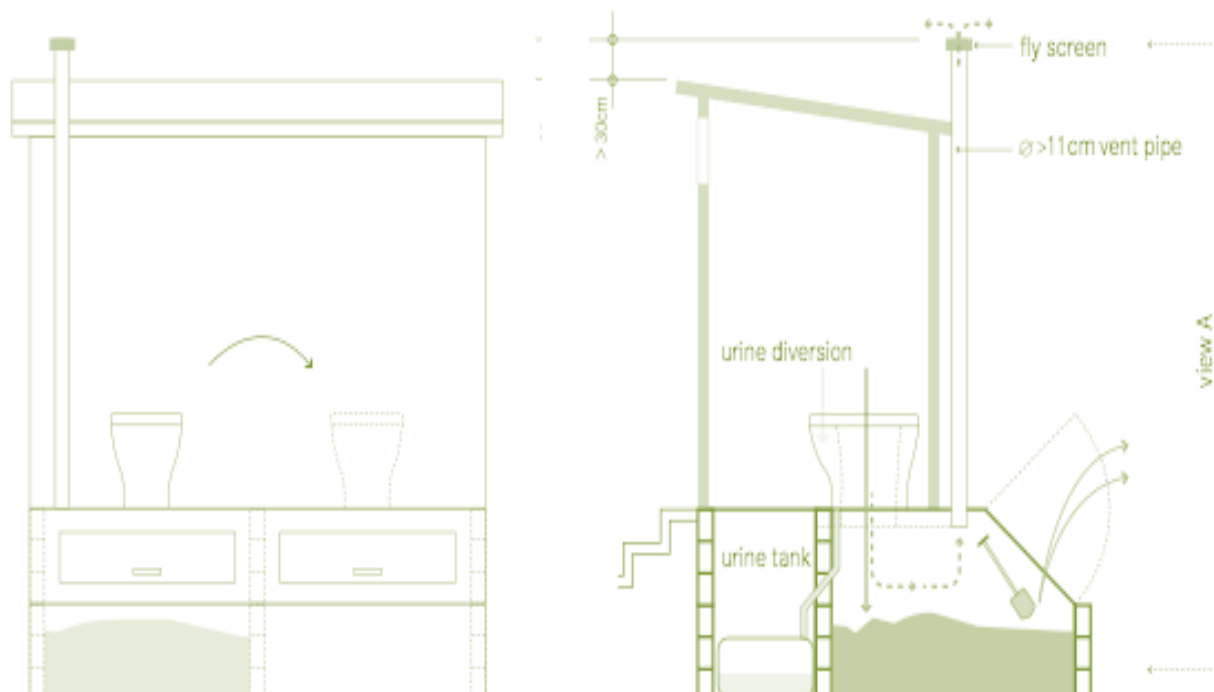

schematic of a 2-chamber UDDT  
(adapted from Tilley 2008 : Compendium of Sanitation Systems and Technologies)

two-chamber UDDT



2-chamber UDDT in a school in Misamis Oriental



ceramic UD bowl



urine container



backside of UDDT



waterless urinal



backside of the 2-chamber UDDT showing the 2 vaults and the vent pipe



orientation of school children on the use of the urine diversion toilet



poster with do's and don'ts placed inside the toilet



interior of the 2-chamber UDDT (concrete UD bowl, buckets for dehydration material & toilet paper, anal washing area)



## operation and maintenance

When defecating, the user should make sure that urine and feces are separated so that no fecal material enters the urine compartment and vice versa. After defecating, the feces should be covered with locally available dehydration materials (lime/sawdust mixture or dried soil, ash, or rice hulls). Feces must be covered properly to hasten the drying process and to prevent the occurrence of unpleasant odor. An ample supply of covering material must always be available. For people who are “wipers,” toilet papers should be thrown in separate trash bin and burned regularly. For people who are “washers,” the separate anal washing area should be used. The lid of the UD bowl should always be closed to prevent flies and vermin from entering. The fecal chamber must always be kept completely dry, and users should prevent water from entering the fecal chamber when cleaning the toilet. The UD bowl should be cleaned with a dry rag or a stick with a damp cloth to prevent water from dripping to the chamber. Users should make sure that water is always available for anal and hand washing.

Once the first vault is full, the second vault can be used while allowing the feces in the first vault to dry. The feces shall be stored for at least one year in the vault and they can then be safely removed from the vault. Although the remaining health risk associated with the 12-month dried feces is minimal, it is still recommended to subject the material to a secondary treatment (see chapter on reuse).

First time users must be oriented on the appropriate use of the UDDT. Posters with the most important Do’s and Don’t’s are available online in English and Cebuano (see also page 21).

## reuse/safe disposal options

The WHO recommends that the collected urine should be stored for around 1 month before it can be safely reused in agriculture. This storage time increases the pH inside the container and kills off all remaining pathogens. Urine can be considered a well-balanced nitrogen-rich, quick-acting liquid fertilizer since nutrients in urine are mostly water soluble, hence, are directly available for plant uptake. Urine is best utilized as a fertilizer for nitrogen-demanding crops such as corn and leafy vegetables (such as lettuce). Urine can be applied either with or without dilution. When applying undiluted urine, water should be applied right after the application of urine. When diluted, the dilution ratio could be between 1:1 (1 part urine to 1 part water) and up to 1:10 (1 part urine to 10 parts water). Urine should be applied 10 cm away from the plants and immediately covered with the soil to avoid loss of ammonia. Urine should not be sprayed on plants to avoid foliar burning. A waiting period of 1 month from the last urine application before harvest of crops should always be observed as an additional safety measure.

Pathogen concentration in feces is usually very high. Thus, for the safe reuse of feces in agriculture, it is critical that it has to be handled in such a way that the risk of disease transmission is minimized and the dried feces are appropriately treated. It is therefore, recommended to store the dry feces for at least 12 months with subsequent aerobic composting (temperature above 50°C should be achieved and maintained for at least 1 week in the compost heap) or vermicomposting (for at around 60 days) as secondary treatment method before it can be considered safe for reuse as organic matter- and nutrient-rich compost in agriculture. After secondary treatment has been completed, the processed feces can be used like any other organic fertilizer where nutrients are slowly released as they are degraded in the soil

by microorganisms. Although initial research trials have shown a safe product after secondary treatment, it is recommended that treated feces should not be used for vegetables but for (fruit) trees to ensure acceptance of the produce by customers and to further minimize health risks.

If there is no further reuse intention or low local acceptance for the feces reuse, the dried feces can also be buried (in areas where the groundwater table is low) and covered with soil.

## adequacy

The double chamber UDDT can be built in rural and urban areas, but it requires a slightly bigger area for construction and a higher budget than for the 1-chamber UDDT. It might therefore not be the preferred solution at a household level, but it has often been implemented successfully in a school environment where it can serve more people and usually can last longer than the 1-chamber UDDTs.

The design can be altered to suit the needs of specific populations (i.e. smaller for children, people who prefer to squat, etc.) or locations. UDDTs are appropriate for almost every climate. In addition, it is a very suitable solution in areas where water is limited or scarce since it is a dry sanitation solution that requires water only for hand washing and anal washing.

Similar to the 1-chamber UDDT, the regular maintenance and the handling of dried feces and urine may prove problematic in some circumstances. The introduction of the UDDTs usually implies a change in user's behavior and the long-term success depends much on proper use, operation, and maintenance. Longer lasting information and awareness campaigns as well as proper monitoring are essential when introducing UDDTs as a new sanitation technology. Experience has shown that acceptance is highest where there is a strong interest in saving water and in making use of the nutrients.

## materials needed and estimated costs per unit (as of 09/2010)

BASIC MATERIALS				
Quantity	Unit	Item	Cost/Unit (PhP)	Subtotal (PhP)
25	bag	Portland Cement	215.00	5,375.00
300	pcs	4" Concrete Hollow Blocks	8.00	2,400.00
1	m <sup>3</sup>	3/4" Gravel	450.00	450.00
1	m <sup>3</sup>	Washed Sand	450.00	450.00
17	lengths	10 mm dia DRB	144.00	2,448.00
9	lengths	8 mm dia DRB	98.00	882.00
105	bd ft	2" x 2" x 8' Coco Lumber	14.00	1,470.00
19	bd ft	4" x 4" x 8' Coco Lumber	14.00	266.00
1	kilo	1" Common Wire Nail	52.00	52.00
2.5	kilos	3" Common Wire Nail	46.00	115.00
3.5	kilos	4" Common Wire Nail	44.00	154.00
2	kilos	#16 Tie Wire	47.00	94.00
1	pc	1" PVC Wye	24.00	24.00
2	pcs	1" PVC 45° Elbow	22.00	44.00

4	m	1" PVC Pipe	23.00	92.00
1	pint	Sealant	105.00	105.00
14	pcs	2" x 3" Door Hinge	15.00	210.00
7	pc	Door Pull	15.00	105.00
5	sheet	G.I. Plain Sheet	220.00	1,100.00
50	bundle	1" Bamboo Strips	60.00	3,000.00
40	pcs	Nipa Shingles	5.00	200.00
1	unit	Concrete UDDT Bowl	200.00	200.00
3	unit	Plastic Urine Container	60.00	180.00
1	unit	Rattan Bukag	200.00	200.00
3	pc	Garbage Bag (black)	5.00	15.00
1	unit	Container for water	120.00	120.00
1	unit	Cup for ash	15.00	15.00
1	unit	Water ladle	20.00	20.00
1	Unit	Soap case	15.00	15.00
1	Unit	Container for ash	110.00	110.00
1	unit	Kitchen sink	650.00	650.00
1	unit	Garbage can	60.00	60.00
6	unit	Plywood (for wall)	240.00	1,440.00
			<b>Total</b>	<b>19,179.00</b>

### ADDITIONAL MATERIAL OPTIONS

(the respective costs for walls and tiles need to be added to the basic material costs)

Walls	1. Option: Amakan Wall					
	Quantity	Unit	Item	Cost/Unit (PhP)	Subtotal (PhP)	
	200	pcs	Nipa Shingles	5.00	1,000.00	
	3	sheets	Bamboo Mat (Amakan)	120.00	360.00	
					<b>Total</b>	<b>1,360.00</b>
	2. Option: Recycled Plastic Wall					
	Quantity	Unit	Item	Cost/Unit (PhP)	Subtotal (PhP)	
	6	sheets	Recycled Plastic	60.00	360.00	
					<b>Total</b>	<b>360.00</b>
	3. Option: Plywood Wall					
Quantity	Unit	Item	Cost/Unit (PhP)	Subtotal (PhP)		
6	Unit	Plywood	240.00	1,440.00		
				<b>Total</b>	<b>1,440.00</b>	
Tiles	4. Option: Flooring Tiles					
	Quantity	Unit	Item	Cost/Unit (PhP)	Subtotal (PhP)	
	100	Unit	Tiles (8 x 8)	15.00	1,500.00	
					<b>Total</b>	<b>1,500.00</b>

- the figures above do not reflect labor costs
- the estimated costs are indicative and might vary in different areas and over time
- US\$ 1 = PhP 43.22 (as of 10/2010)



1 preparation of the basement



2 building of the concrete substructure



3 constructing of the wooden frame for the superstructure



3 constructing of the wooden frame for the superstructure



4 outer view of a 2-chamber UDDT



5 handwashing facility & waterless urinal

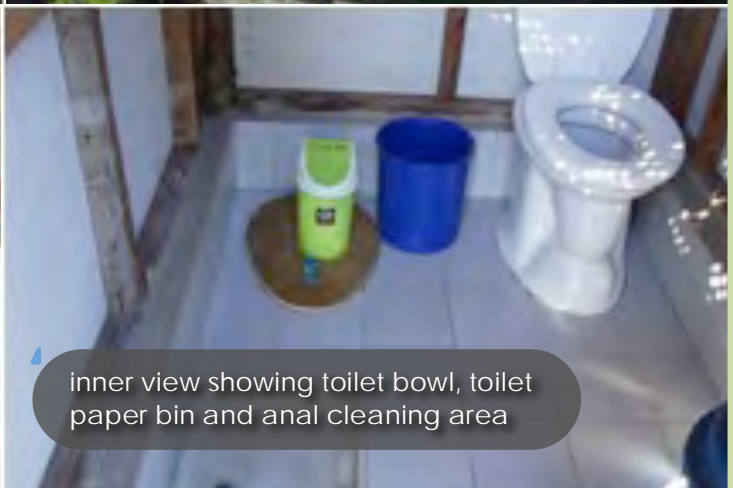

inner view showing toilet bowl, toilet paper bin and anal cleaning area

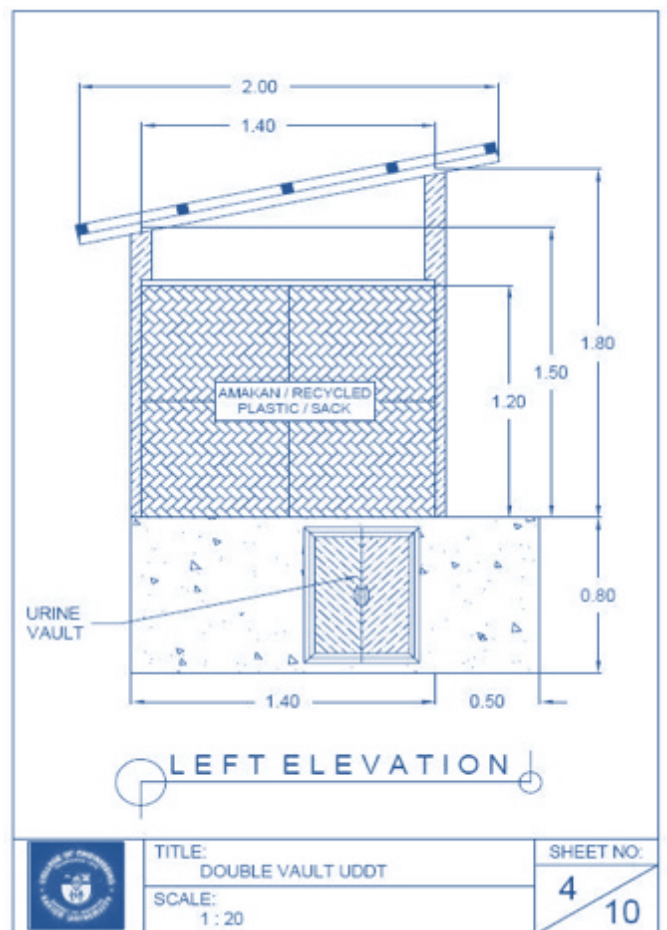
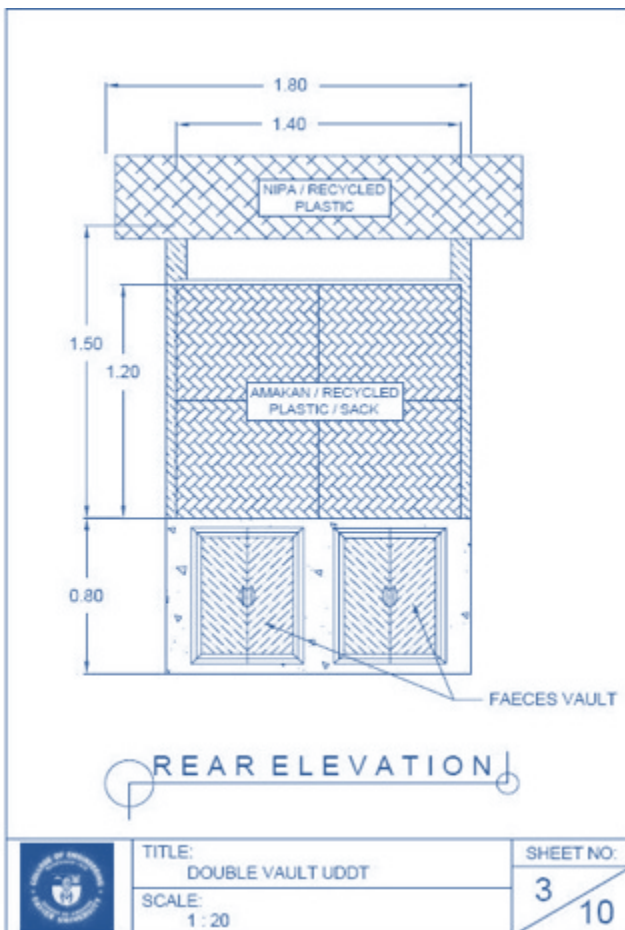
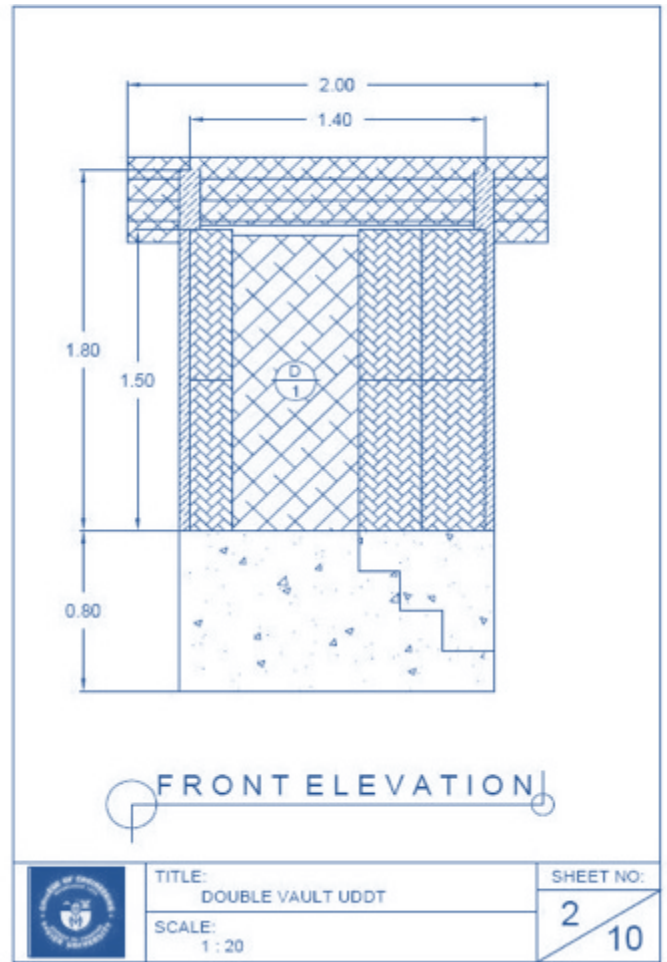
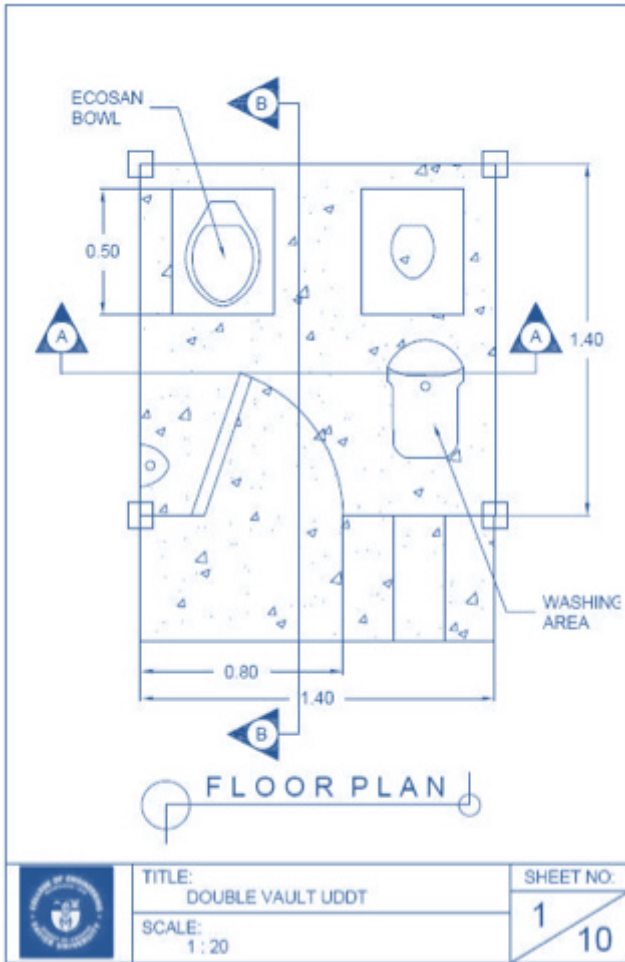

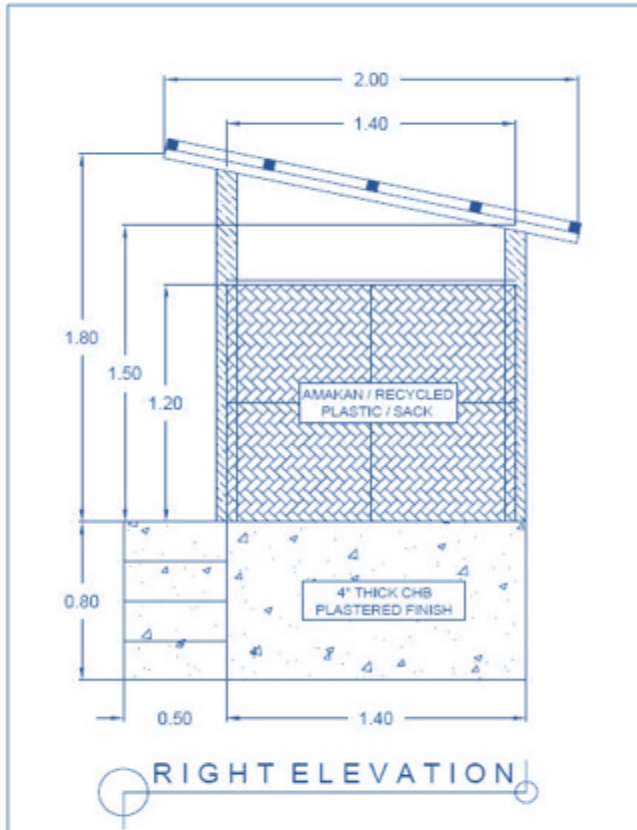

	TITLE: DOUBLE VAULT UDDT	SHEET NO: 5
	SCALE: 1 : 20	10

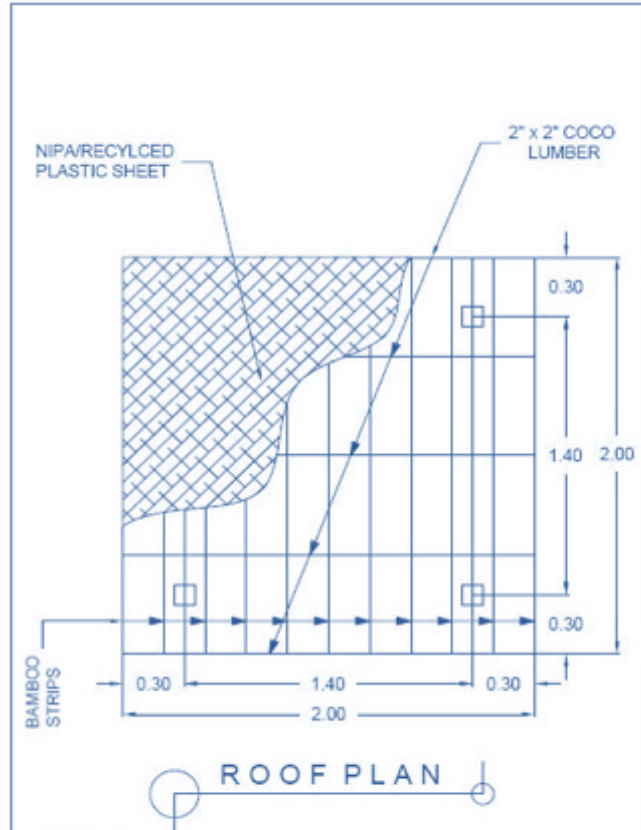

	TITLE: DOUBLE VAULT UDDT	SHEET NO: 6
	SCALE: 1 : 20	10

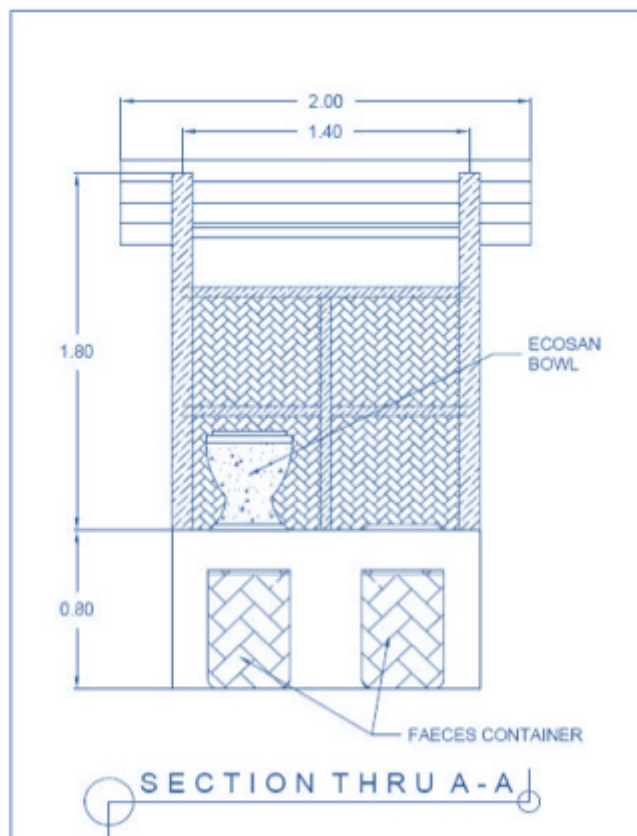

	TITLE: DOUBLE VAULT UDDT	SHEET NO: 7
	SCALE: 1 : 20	10

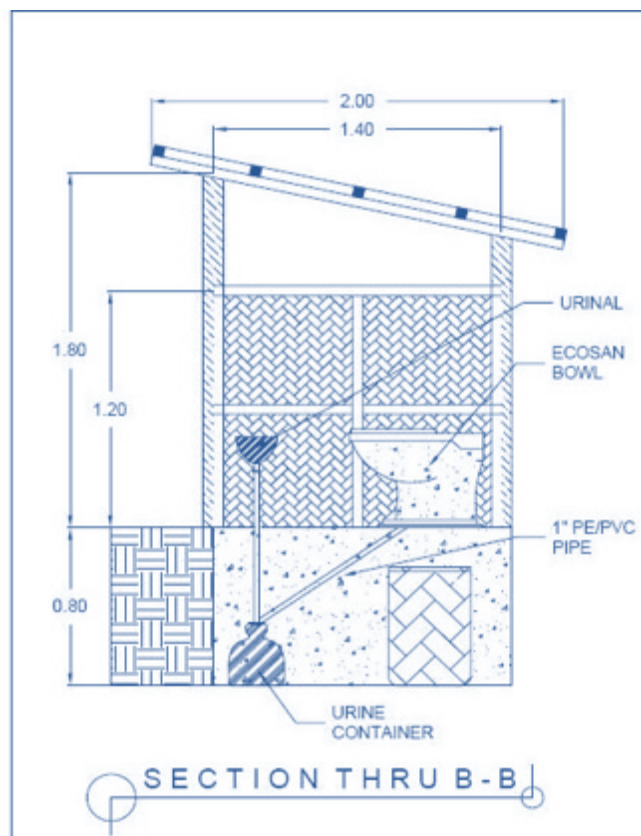

	TITLE: DOUBLE VAULT UDDT	SHEET NO: 8
	SCALE: 1 : 20	10

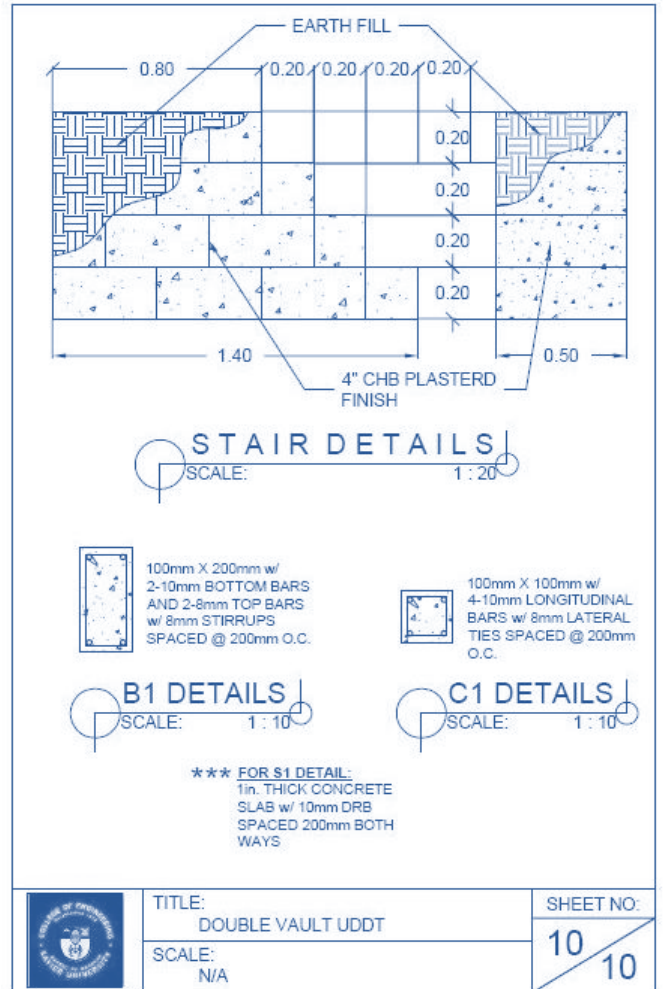
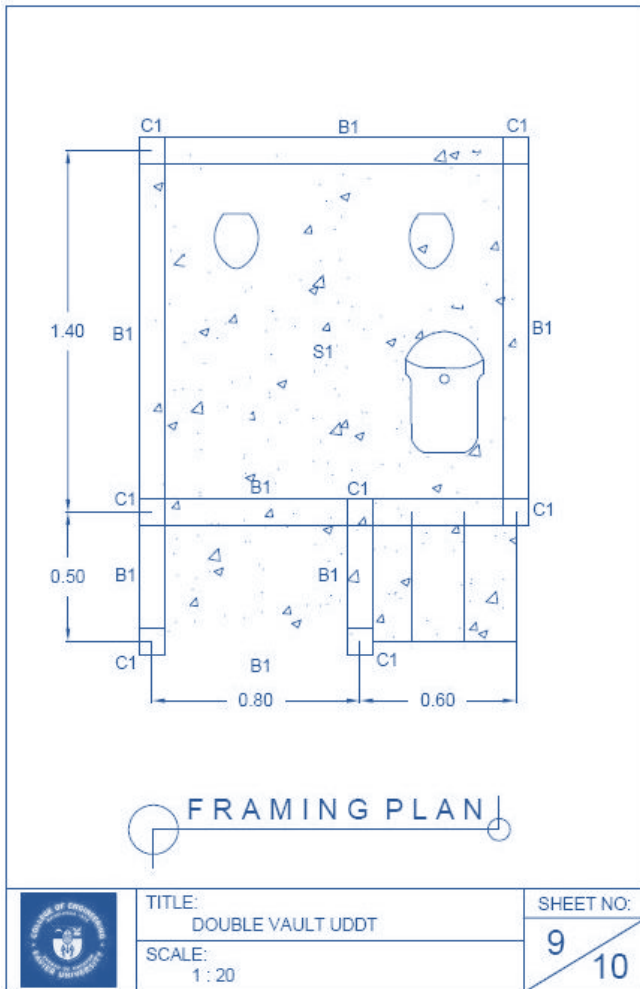



## low-cost sustainable sanitation technologies

### the hanging UDDT

The hanging UDDT is a 1-chamber UDDT specifically designed for coastal communities where houses are built on stilts. The toilet is directly integrated into the house and the urine and feces collection substructure is put underneath the houses in a 'hanging style.' This solution is geared towards promoting sustainable sanitation in depressed communities located along coastal areas with little or no sanitation primarily because of the lack of space and resources. Like in the 1-chamber UDDT, urine and feces are collected separately. Urine is collected in a 20-liter jerrican and the feces are collected in a bucket lined with a plastic sack. Since there is often no possible direct use of urine and feces in coastal areas, there is a need to provide for a regular collection and transport service from the coastal households to a treatment facility (storage and vermicomposting), which should be ideally located close to the agricultural reuse area.

The implementation of hanging UDDTs provides a dignified, safe and sustainable sanitation solution for coastal communities, which has a direct positive impact on health, food security, and the environment. Instead of direct defecation into the sea that constantly contaminates water bodies, urine and feces are safely stored and reused. In addition, with the use of urine and feces in agricultural production, the fertilizer and soil conditioner potential of the resources is tapped and at the same time eutrophication of coastal areas is reduced.

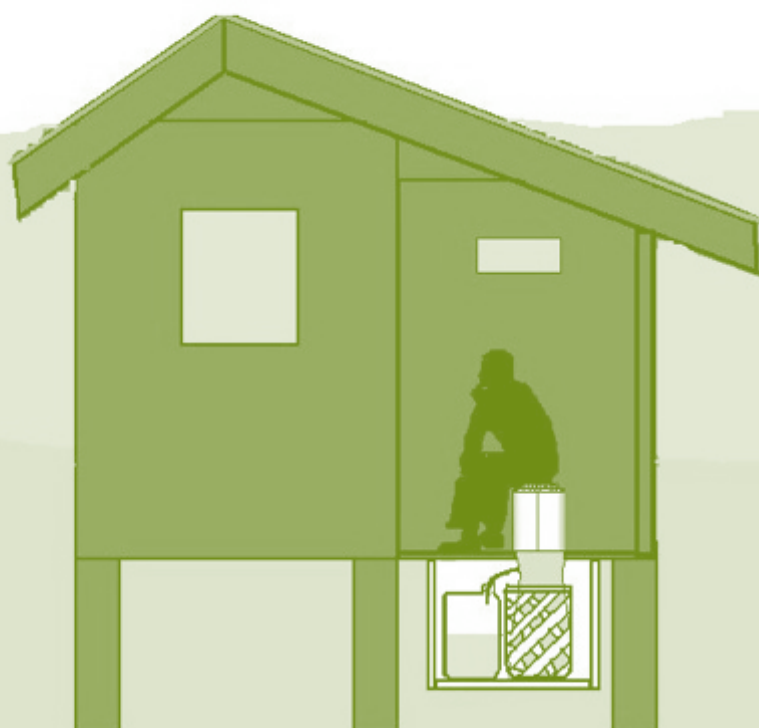

schematic of a hanging UDDT



hanging UDDT in a house along the coast in Initao, Misamis Oriental



substructure underneath the toilet with separate container for urine & feces collection



outer structure of the toilet



interior of a hanging UDDT with user instructions on the door



interior of a hanging UDDT



hanging UDDT attached to a coastal house in Initao, Misamis Oriental



substructure of a hanging UDDT

## operation and maintenance

The operation and maintenance required for the hanging UDDTs is similar to the above mentioned 1-chamber UDDT. When defecating, the user should make sure that urine and feces are separated so that no fecal material enters the urine compartment and vice versa. After defecating, the feces should be covered with locally available dehydration materials and feces must be covered properly to hasten the drying process and to prevent the occurrence of unpleasant odor. Covering material must always be available. Toilet paper should be thrown in a separate trash bin and burned regularly. The lid of the UD bowl should always be closed to prevent flies from entering. The fecal chamber must always be kept completely dry and users should aim to prevent water from entering the fecal chamber when cleaning the toilet. The UD bowl should be cleaned with a rag or a stick with a damp cloth. It should be ensured that first time users must be oriented on the appropriate use of the UDDT. When the plastic sack inside the fecal storage compartment is full, it has to be removed and replaced with a new sack. The filled-up sacks, as well as the urine containers, can be stored close to the toilets until collected by a local service provider (collection is either weekly or monthly depending on the amount that accumulates) and brought to the agricultural area for further treatment and agricultural utilization. The collection and reuse aspect, as well as the potential need for a local service provider, needs to be considered in the planning right from the beginning.

## reuse/safe disposal options

After respective secondary treatment of the feces (storage and vermicomposting), the material can be used to fertilize permanent crops like coconuts and fruit trees. Urine only needs to be stored for 1 month before reused as a liquid fertilizer (see chapter on reuse). If coastal residents have small gardens or container gardens, urine can be directly used as a liquid fertilizer.

## adequacy

Hanging UDDTs are appropriate in communities located along coastal areas with little or no sanitation. Such coastal communities have to deal with frequent and regular high water level brought about during high tide. In addition, these communities are often densely populated with little space for additional toilet infrastructure. Hanging UDDTs offer a very simple technology promoting a dignified, safe and sustainable sanitation solution for coastal communities that have a direct positive impact on health, environment, and food security. Instead of open defecation into or close to the sea that constantly contaminates water bodies, urine and feces are safely stored and reused.

## materials needed and estimated costs

Since the exact measurements of each hanging UDDT depend very much on the local housing conditions, it is difficult to give exact figures here. However, the materials needed are basically the same as for the 1-chamber UDDT and usually cost less since lesser substructure support underneath each toilet is needed.

## how to build

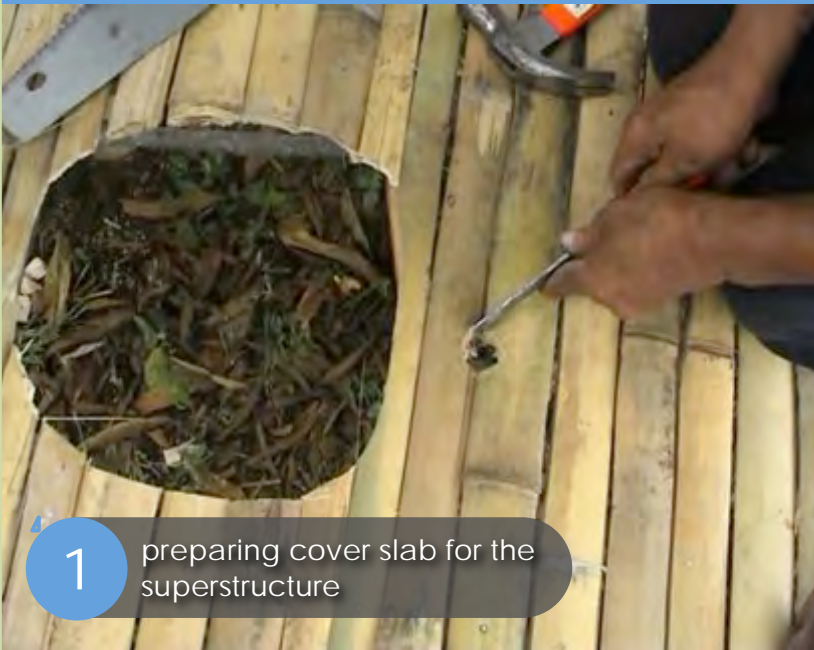

1 preparing cover slab for the superstructure

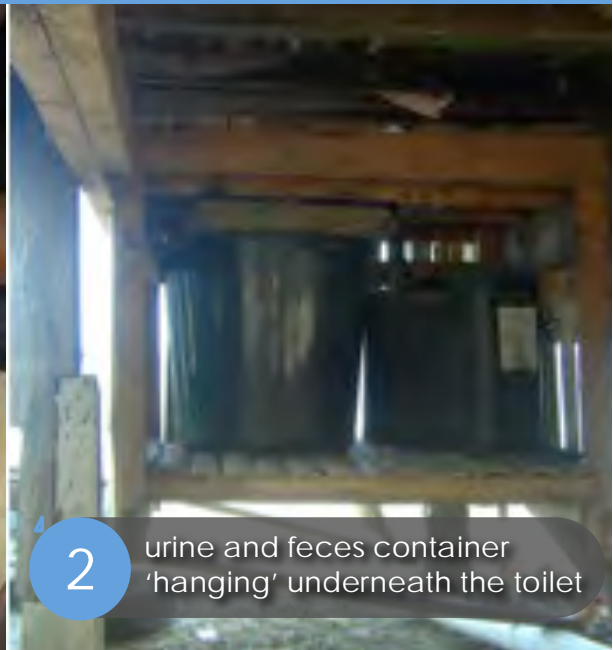

2 urine and feces container 'hanging' underneath the toilet

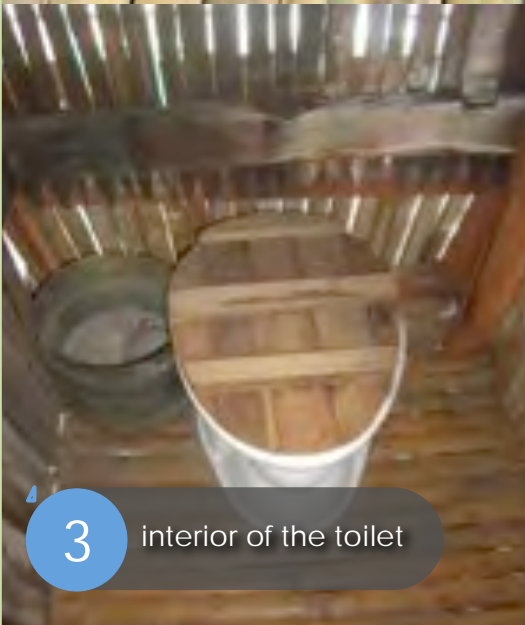

3 interior of the toilet

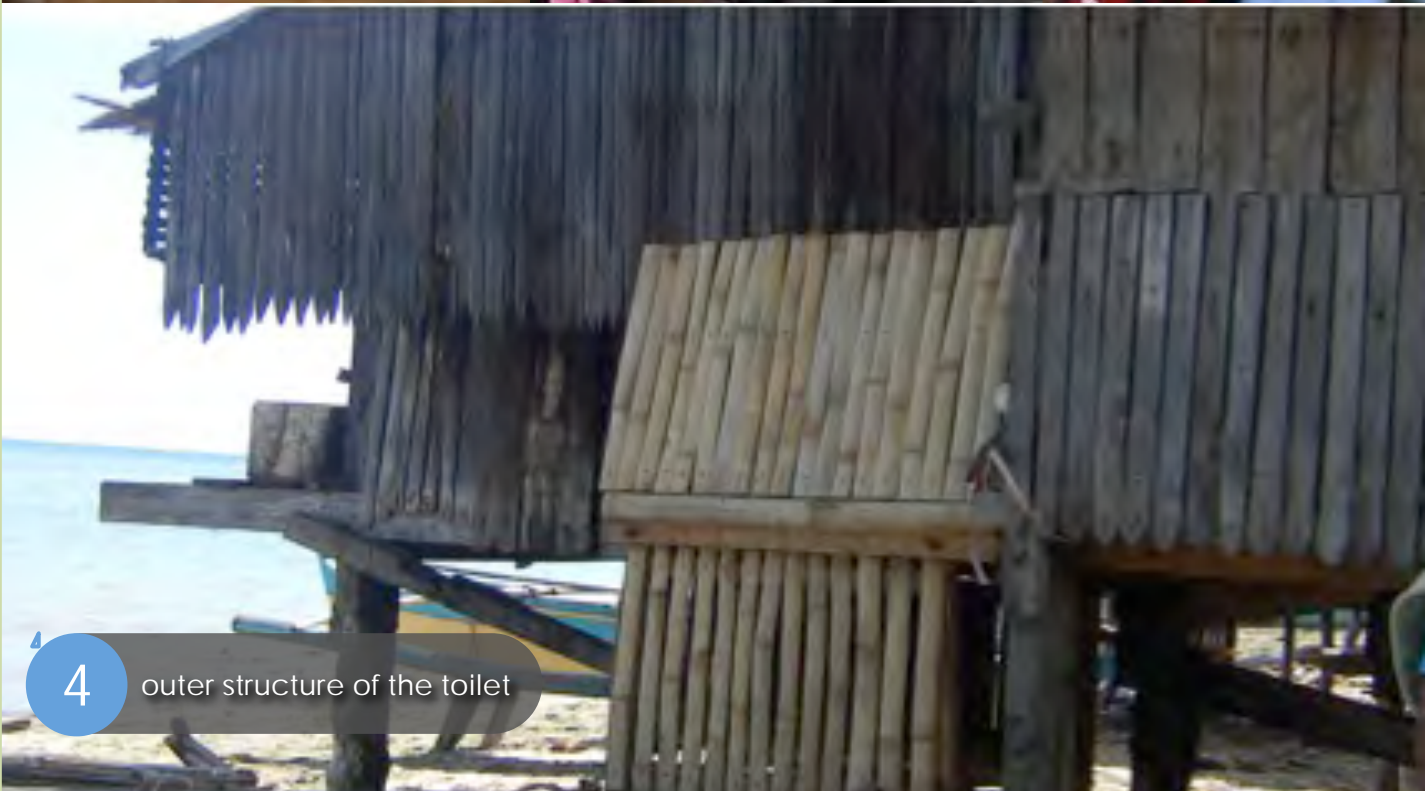

4 outer structure of the toilet

## low-cost sustainable sanitation technologies

### the ecopee

An ecopee (also known as eco-lily) is a waterless urinal for men made out of recycled 20-liter plastic containers and 2-liter plastic bottles placed on top so that it can be used as a urinal. Urinating will be done directly into the open portion of the funnel-like inverted bottle on the top.

Ecopees can be used as independent urinals or as a complement to any of the earlier described toilets. They allow for a quick and easy way of collecting urine separately and may increase the cultural acceptance of the toilet facilities especially by men who usually prefer to stand during urination.

To prevent odor and nitrogen losses, a used light bulb that acts as a one-way valve and opens and closes the container automatically during and after use or a small charcoal sack may be placed permanently into the funnel.

When the ecopee is full, the upper inverted funnel will be screwed loose and the urine can either be stored for 1 month and reused directly or the urine can be collected, transported and poured into a bigger holding container (e.g. 200l drums) for later reuse. Recycled 200l drums can be used for the semi-central urine collection as well as for other purposes like rainwater and greywater collection. The recycled drums can be either of plastic or steel. In the Misamis Oriental example, steel drums are used since they are cheaper than the plastic drums, although the advantage of the plastic drums is that they do not rust.

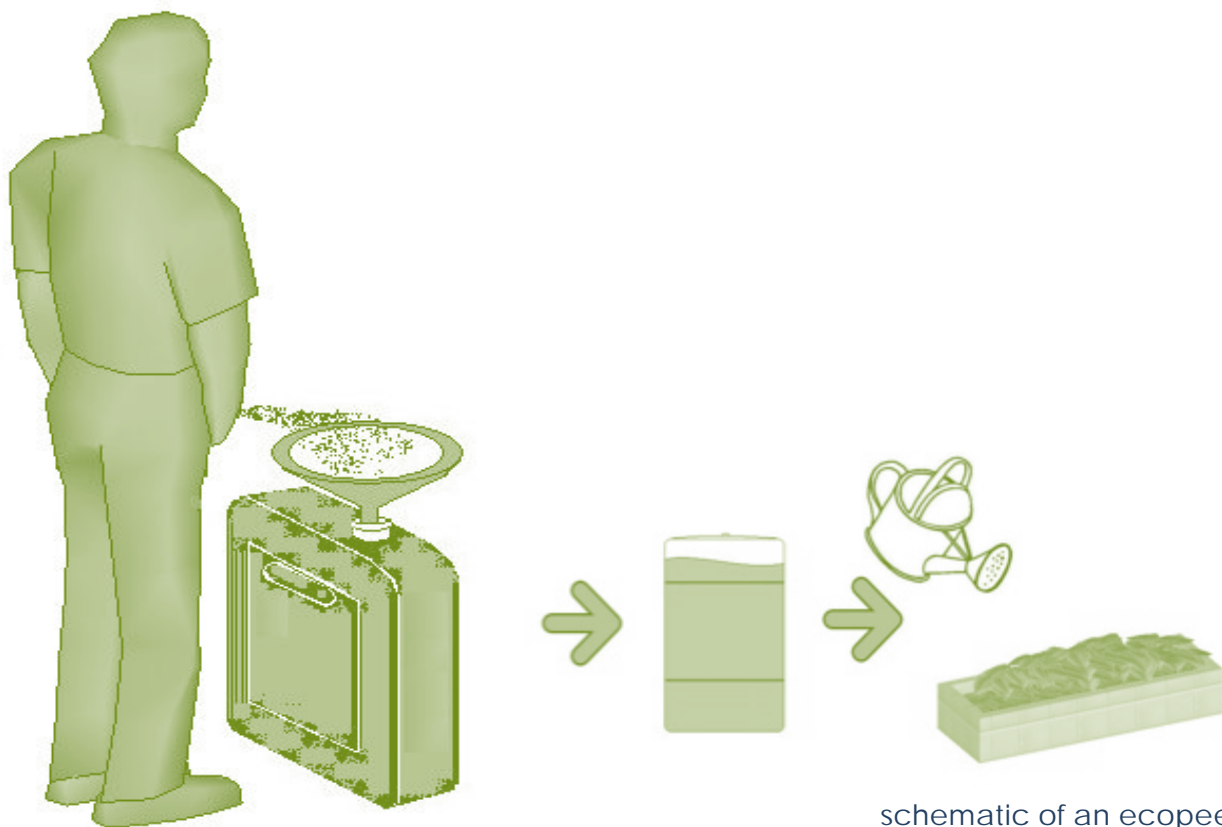

schematic of an ecopee





## operation and maintenance

The ecopee is not very demanding in terms of maintenance. The most critical issues here are the potential loss of ammonia and a slight smell if kept continuously open. Since the main interest in collecting the urine is the direct reuse in agricultural production, it should be ensured that the ammonia losses will be reduced to a minimum by leaving the container closed when not in use. Regular decanting or emptying of the jerricans/containers into bigger 200l drums should be done when needed in case the urine is not yet ready for use. The ecopees should be regularly cleaned with water whenever the need arises.

## reuse/safe disposal options

Urine from the ecopee can be readily used as fertilizer for plants since urine is almost sterile, though it is still recommended that 1 month storage prior to application should be done.

## adequacy

The ecopee is specially designed, appropriate for males and complement existing toilets. The ecopee offers an excellent entry point for all those who would like to initiate more sustainable practices in sanitation and are keen on directly making use of the fertilizer value of urine. Ecopees can be implemented almost everywhere and can also be used as public urinals.

## materials needed and estimated costs

The materials needed include a 20-liter plastic container, a 2-liter plastic bottle, and a piece of poly pipe. If recycled materials are used, the overall cost is approximately 50-60 PhP.

## how to build



1 recycled container & water bottle



2 cutting the water bottle into half



3 placing cut water bottle upside down on top of the container

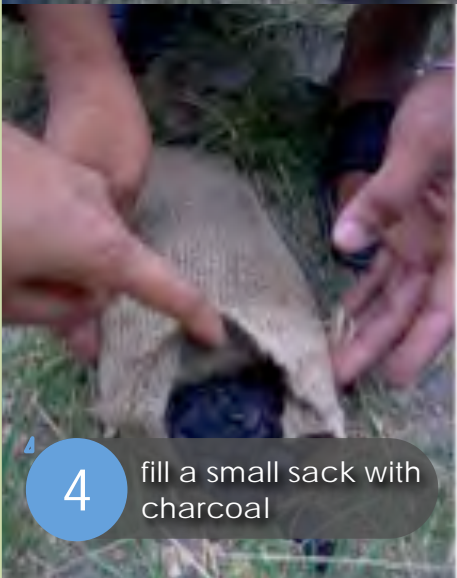

4 fill a small sack with charcoal



5 place charcoal in funnel to prevent smell

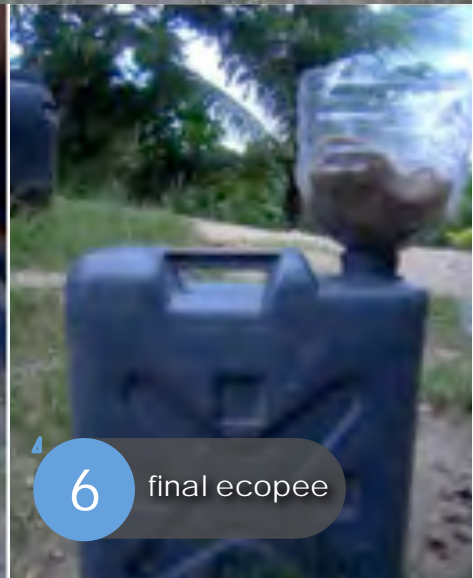

6 final ecopee

## management of the sanitation system

### the sanitation system

Sanitation is a multi-step process or system that does not end with the construction of the toilet. Human excreta, like any other waste produced at a household level, needs to be managed from the point of generation up to the point of use or final disposal. Adequate collection, transport (if needed), proper treatment, and final reuse/safe disposal of the accumulated resources need to be integrated into the entire planning and management process.



The following chapter provides some general and predominantly picture-based guidance on some basic aspects to be considered during the collection, transport, treatment, and final reuse or disposal of human excreta.

## management of the sanitation system

### collection and transport

If space for proper storage, treatment (storage and vermicomposting) and agricultural reuse is available on-site, there is no need for any additional collection and transport infrastructure. However, in more densely populated urban areas as well as in many coastal communities, on-site treatment and reuse of urine and feces are often not a feasible solution since available space for treatment and agricultural production is often limited or lacking, water tables are too high, or people are simply not interested in handling and using the excreta products. In such cases, a proper collection and transportation system has to be put in place to make sure that the collected urine and feces from the households do not accumulate untreated and that these resources can be brought to agricultural areas where they can be productively used.

Except for the arborloo toilet and the 2-chamber UDDT where the collection, storage and later reuse are usually managed on-site, a semi-central collection and transport system can be introduced for all other technologies (1-chamber UDDT, hanging UDDT and ecopee). At the household level, the feces can be collected in plastic sacks, while the urine can be collected in 20-liter jerricans. Depending on how many people per household are using the toilet facility, a 20-liter urine container usually fills up within 3-7 days, while the sack for the feces collection needs to be replaced every 2-4 weeks.

Several bigger collection containers like recycled 200-liter drums can be placed in the area (1 drum for around 4-6 households) where each household can dispose of the full 'feces bags' for later collection. The households need to be instructed that the drums should always be kept closed so that no rainwater (and vermin) get into the drums. In addition, each household will be provided with several 20-liter jerricans for the urine collection in order to allow the families to exchange the containers regularly once they are full.

A local service provider, such as farmers interested in the fertilizer products or the municipality as part of its regular waste collection services, will collect the feces bags and urine jerricans on a regular basis via truck or motorcycle. Communities usually prefer to have the urine and feces collected rather frequently because of the health risks the long period of accumulation of urine and feces may bring (e.g. through roaming animals). During collection, the full urine containers will be replaced with empty containers and new plastic sacks for the feces will be provided. The urine and feces will be brought to the farming areas where the urine is decanted into bigger 200-liter drums close to the fields and the feces further processed (storage and vermicomposting). The collection should be scheduled regularly depending on the amount generated (either weekly or monthly). Since the feces are collected in plastic sacks, the health risks to the collectors are only marginal. However, it is always recommended that the collectors should wear protective equipment including gloves, masks and rubber boots.



filled urine containers stored under the toilet for later collection



collection of urine containers from the households



provision of empty urine containers to the households



200-liter drum provided for feces collection and temporary storage from several households

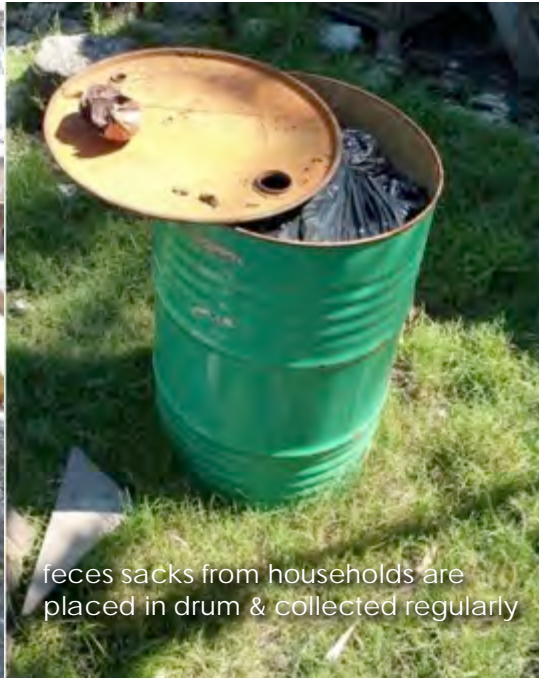

feces sacks from households are placed in drum & collected regularly



collection of feces sacks from the households



collection of urine containers and feces sacks from the households and transport to a treatment facility close to the agricultural reuse areas



feces storage shed close to vermicomposting area and the agricultural reuse site



decanting of urine from smaller jerrycans into 200-liter storage drums close to the field



collection and transport

## management of the sanitation system

### treatment options

**Urine treatment:** Although urine is an almost sterile medium, cross-contamination with fecal material may occur during the collection, and it is always recommended that urine should be stored in a sealed container for at least 1 month. Storage of urine in closed jerricans will lower the health risk considerably. After 1 month in a closed container, all pathogens in the urine will be destroyed due to the formation of ammonia that increases the pH up to 9 and the urine can then be safely reused as a liquid fertilizer in agriculture.

**Feces treatment:** Feces usually contain a wide range of pathogenic organisms of viral, bacterial, parasitic protozoan and helminths origins that can cause severe gastrointestinal symptoms such as diarrhea and vomiting. Therefore, feces need to be appropriately treated before they are used in agriculture or safely discharged into the environment (if no reuse is intended). As a primary treatment, the feces should be stored in the UDDT storage vaults or the collected plastic sacks from the 1-chamber UDDT as long as possible. The World Health Organization recommends a minimum storage time of 6 months (WHO, 2006), but based on recent research results (Itchon et al., 2009), it is recommended to extend this storage time under Philippine conditions to a minimum of 1 year or more, followed by an additional secondary treatment. Secondary treatment of dehydrated feces should always be considered as an additional barrier to inactivate pathogens like *Ascaris* eggs. The stored feces can be subjected to any of the following secondary treatments: (1) aerobic composting where a temperature of above 50°C should be achieved and maintained for a duration of at least 1 week in the compost heap or (2) vermicomposting for around 60 days. After secondary treatment, the product from the composting process can be considered safe for reuse. However, it is recommended that treated feces should better not be used for vegetables but for (fruit) trees, which the harvestable part is at a considerable distance from the soil, ensuring a higher acceptance by customers and minimizing any remaining health risks.

-

- ▶ WHO (2006): Guidelines for Safe Use Wastewater, Excreta and Greywater, Volume 4: Excreta and Greywater Use in Agriculture, Geneva, World Health Organisation
- ▶ Itchon, G., Holmer, R., Tan, L. (2009): Observational Study to Determine the Length of Time Necessary to Eradicate Parasitic Ova and Pathogenic Bacteria in Human Excreta Kept in the Storage Vaults of Urine Diverting Dehydration Toilets in Cagayan de Oro City, Philippines, 2007-2008





storage and dehydration of feces in UDDT vaults for 1 year



storage of collected feces close to vermicomposting site



vermicomposting area for secondary treatment of feces after storage

## management of the sanitation system

### agricultural reuse of urine, feces and composting products

Use of urine: Urine is a liquid product of the human body and a substantial part of the soluble substances in urine is composed of essential plant nutrients like nitrogen (N), phosphorus (P) and potassium (K) often referred to as macronutrients. These nutrients are coming from the daily food intake and almost all consumed nutrients leave the body again with the excreta. Urine contains most of the macronutrients as well as smaller fractions of micronutrients in a form readily available for plants and is particularly rich in nitrogen. Urine, therefore, can be considered a well-balanced, liquid fertilizer with comparable results as those achieved with synthetic fertilizers. Urine can be applied to small fields and beds, vertical gardens, school gardens, plant pots on terraces, rooftops, and almost everywhere where space, adequate soil, and sunlight can be ensured. The use of urine is not limited to rural areas and can easily be adopted in urban environments as long as space is available. Urine can be applied neat or diluted with water. There is no standard recommendation for dilution. However, if urine is applied at small-scale level where transport of the relatively heavy urine is not a constraint, it is recommended to dilute the urine. Advantages of dilution are a noticeable odor reduction and a decreased risk of over-application. On the other hand, it increases the total volume to be spread and thus labor and transport. Fertilization with urine should stop after between 2/3 and 3/4 of the time between sowing and harvest and a waiting period of 1 month between fertilization and harvest should always be observed as an additional safety barrier. For best fertilizing effect and to avoid ammonia losses, urine should be incorporated into the soil as soon as possible. Application equipment comprises watering cans, dippers, old water bottles, etc. Shallow incorporation is enough, and different methods are possible. One is to apply urine in small furrows that are covered after application. Washing the nutrients into the soil with subsequent application of water is another. When spreading urine, it should not be applied to leaves or other parts of the plants, as this can cause foliar burning. Spraying urine in the air should also be avoided due to the risk of nitrogen loss through gaseous emissions of ammonia and the hygiene risk through aerosols (adapted from Richert et al., 2010).

Use of feces and composting products: Urine application can be complemented with other nutrient and organic matter sources. Source-separated and composted feces are recommended due to their high organic matter content and the high P and K concentrations, given that they are acceptable to users and associated health risks can be properly managed (see treatment chapter). In addition to the nutrients, feces contain organic matter, which increases the water-holding and ion-buffering capacity of the soil, serves as food for soil microorganisms, and improves soil structure. Composted feces should be applied prior to planting time.

Safe disposal option: If the overall acceptance of the feces handling and reuse are rather low, the collected feces can also be buried (given that the groundwater table is low). This can even be done productively in such a way that the sacks with the feces are buried close to fruit trees like coconut or banana trees.

-

- ▶ Richert, A., Gensch, R., Dagerskog, L., Joensson, H., Stenstroem, T.-A. (2010): Practical Guidance for the Use of Urine in Crop Production, SEI, EcoSanRes Series 2010-1, Stockholm Sweden



urine application with watering can



urine dilution at the agricultural production site



eggplants fertilized with urine



application of diluted urine close to the ground

## further information, useful links and contacts

### further reading material

- ▶ DOH 2010: Philippine Sustainable Sanitation Sector Roadmap, Department of Health, Manila, Philippines
- ▶ MORGAN, P. (2008): Toilets That Make Compost – Low-Cost Sanitary Toilets that Produce Valuable Compost for Crops in an African Context, Practical Action Publishing, UK
- ▶ PUVEP (2008): Philippine Allotment Garden Manual with an Introduction to Ecological Sanitation. Periurban Vegetable Project, Xavier University Research and Social Outreach, Cagayan de Oro, Philippines
- ▶ RICHERT, A., GENSCHE, R., JOENSSON, H., STENSTROEM, T., DAGERSKOG, L. (2010): Practical Guidance on the Use of Urine in Crop Production: EcoSanRes Programme Stockholm Environment Institute Kräftriket 2B, Stockholm, Sweden.
- ▶ SUSANA (2008): Towards More Sustainable Sanitation Solutions, Sustainable Sanitation Alliance vision document, version 1.2, February 2008
- ▶ TILLEY, E., LÜTHI, C., MOREL, A., ZURBRÜGG, C., SCHERTENLEIB, R. (2008): Compendium of Sanitation Systems and Technologies, Switzerland, Swiss Federal Institute of Aquatic Science (EAWAG) & Water Supply and Sanitation Collaborative Council (WSSCC)
- ▶ VON MUENCH, E., WINKER, M. (2009): Technology Review – Overview of Urine Diversion Components such as Waterless Urinals, Urine Diversion Toilets, Urine Storage and Reuse Systems, German Technical Cooperation, Eschborn, Germany
- ▶ WHO (2006): Guidelines for Safe Use Wastewater, Excreta and Greywater, Volume 4: Excreta and Greywater Use in Agriculture, Geneva, World Health Organisation
- ▶ WSP (2005): Philippines Sanitation Sourcebook and Decision Aid, Water and Sanitation Program of Worldbank, Water Supply and Sanitation Performance Enhancement Project, Philippines
- ▶ WSP-EAP (2008): Economic Impacts of Sanitation in the Philippines, Water and Sanitation Program – East Asia and Pacific, World Bank & USAID, Manila, Philippines

### online discussion groups

- ▶ Ecosan-Philippines: <http://tech.groups.yahoo.com/group/ecosan-philippines>
- ▶ EcoSanRes (globally): <http://tech.groups.yahoo.com/group/ecosanres>

## websites

- ▶ Center for Advanced Philippine Studies (CAPS): [www.caps.ph](http://www.caps.ph)
- ▶ Ecosan Program of German Technical Cooperation (GTZ): [www.gtz.de/ecosan](http://www.gtz.de/ecosan)
- ▶ EcoSanRes Program of Stockholm Environment Institute (SEI): [www.ecosanres.org](http://www.ecosanres.org)
- ▶ Periurban Vegetable Project: [www.puvep.xu.edu.ph](http://www.puvep.xu.edu.ph)
- ▶ Philippine Ecosan Network (PEN): [www.ecosan.ph](http://www.ecosan.ph)
- ▶ Sustainable Sanitation and Water Management (SSWM) Toolbox: [www.sswm.info](http://www.sswm.info)
- ▶ Sustainable Sanitation Alliance (SuSanA): [www.susana.org](http://www.susana.org)
- ▶ Water, Agroforestry, Nutrient Development (WAND): [www.wandphilsorg.com](http://www.wandphilsorg.com)
- ▶ XU SUSAN Center: [www.susancenter.xu.edu.ph](http://www.susancenter.xu.edu.ph)

## resource organizations and institutions in the Philippines

- ▶ Sustainable Sanitation Center  
Xavier University – Ateneo de Cagayan  
phone: +63-88-8583116 loc 1103  
website: [www.susancenter.xu.edu.ph](http://www.susancenter.xu.edu.ph)  
contact persons:  
Robert Gensch: [robert.gensch@web.de](mailto:robert.gensch@web.de)  
Gina Itchon: [gsijuly18@yahoo.com](mailto:gsijuly18@yahoo.com)  
Analiza Miso: [annamiso1980@gmail.com](mailto:annamiso1980@gmail.com)
- ▶ Water, Agroforestry, Nutrition and Development (WAND) Foundation  
address: Lubluban, Libertad 9021, Misamis Oriental, Philippines  
phone: +63-9218041573  
contact person: Elmer Sayre
- ▶ Centre for Advanced Philippine Studies (CAPS)  
address: 120-A K-8th Street, East Kamias, Quezon City, Philippines  
phone: +63-2-4339042  
website: [www.caps.ph](http://www.caps.ph)  
contact persons: Dan Lapid, Dr. Lilia Casanova, Leo de Castro



Sustainable Sanitation Center  
Xavier University – Ateneo de Cagayan  
Cagayan de Oro City  
Philippines 9000  
[www.susancenter.xu.edu.ph](http://www.susancenter.xu.edu.ph)