

The Black Water Loop: Water Efficiency and Nutrient Recovery Combined

Dem Promotionsausschuss der Technischen Universität Hamburg-Harburg
zur Erlangung des akademischen Grades

Doktor-Ingenieur (Dr.-Ing.)

vorgelegte Dissertation

von
Björn Lindner

aus
Hamburg

2007

Abstract

Ziel dieser Arbeit ist die Entwicklung eines Verfahrens zur Aufbereitung von Schwarzwasser zu einem Toilettenspülwasser, welches allen hygienischen und ästhetischen Anforderungen genügt (Schwarzwasserkreislauf). Zusätzlich sollen die Nährstoffe im Schwarzwasser einer Nutzung zugeführt werden können, anstatt wie bei konventionellen Systemen in einer Kläranlage aufwändig vernichtet zu werden.

Im Rahmen dieser Dissertation wurden alle erforderlichen Aufbereitungstechnologien dafür ausgewählt und auf ihre Eignung hin überprüft. Die generelle technische Machbarkeit sowie das Zusammenspiel der Komponenten wurden anhand einer halbtechnischen Anlage demonstriert, welche eigens für dieses Projekt im Institut für Abwasserwirtschaft und Gewässerschutz der Technischen Universität Hamburg-Harburg (TUHH) installiert und über einen Zeitraum von ca. 16 Monaten betrieben wurde.

Die Untersuchungen lassen vier zentrale Schlüsse zu:

Trotz hoher Stickstoffzulaufmengen ist eine stabile biologische Behandlung von Gelb- bzw. Schwarzwasser mit dauerhaft stabiler Nitrifikation möglich.

Durch die biologische Aufbereitung lässt sich ein geruchsfreier Ablauf dieses hoch konzentrierten Abwasserteilstroms erreichen.

Eine Entfärbung des Mediums war unter den getesteten Verfahren nur durch eine Behandlung mit Ozon bzw. UV-C Bestrahlung (inklusive Strahlung der Wellenlänge von 185 nm) möglich.

Keimuntersuchungen belegen, dass durch die verwendeten Aufbereitungsverfahren die hygienischen Anforderungen gewährleistet werden können.

Interne Befragungen der Nutzer ergaben ein hohes Maß an Akzeptanz für das System.

Mit Hilfe einer Kostenvergleichsrechnung wird die Wirtschaftlichkeit des Schwarzwasserkreislaufs gegenüber dem klassischen End-of-Pipe-System verdeutlicht. Hierbei werden auch Kombinationen mit Verfahren zur Grauwasseraufbereitung untersucht.

Abschließend werden Möglichkeiten für zukünftige Verfahrensoptimierungen aufgezeigt und Hinweise für das Up-Scaling und entsprechende Systemanpassungen gegeben.

Objective of this thesis is to develop a system for purification of black water for its reuse as a toilet flush water, which fulfils all hygienic as well as aesthetic needs (black water loop). Additionally the nutrients contained in the black water stream should be reused, instead to be eliminated in a complex process on a waste water treatment plant.

Within this dissertation all necessary purification technologies are selected and tested regarding their applicability. The overall technical feasibility as well as the interaction of all components was investigated and proved by operation of a pilot plant, which was constructed at the Institute of Waste Water Management and Water Protection of the Hamburg University of Technology (TUHH). It was operated over a period of time of approximately 16 months duration.

These investigations resulted in four basic statements:

Despite high nitrogen concentrations in the inflow a stable biological treatment of black and yellow water with a stable nitrification is possible.

Even for this highly concentrated waste water stream the removal of the odour is possible simply by biological treatment.

Among all tested technologies just the treatment by ozone respective by UV-C irradiation (including wavelengths of 185 nm) was successful in colour removal for the investigated circumstances. Control of germs showed that the hygienic needs are completely fulfilled by the selected purification steps.

An internal conducted survey led to very good results regarding the user acceptance of the systems. The economic benefits were investigated by a cost comparison of combinations of the black water loop with two different systems for grey water purification on the one and the conventional end-of-pipe system on the other hand.

Finally possibilities for future system optimisations are listed as well as hints for the up-scaling and related system adjustments.

El objetivo de esta tesis es el desarrollo de un sistema para la purificación de las aguas negras con el fin de reutilización como aguas de enjuague, que satisface todos aspectos de higiénica y las necesidades estéticas (circulación de la agua negra). Los nutrientes contenidos en la corriente del agua negra se pueden reutilizar en lugar de ser eliminado en un proceso complejo en una estación depuradora.

En esta disertación todas las tecnologías necesarias de la purificación fueron seleccionando y probaron con respecto a su aplicabilidad. La factibilidad técnica total y la interacción de todos los componentes es investigada y probada en la operación de una planta piloto, que fue construida en el Instituto de la Gestión de Aguas Servidas y la Protección de Recursos Hídricos de la Universidad Tecnológica de Hamburgo (TUHH).

Las investigaciones, que eran en un experimento de aproximadamente 16 meses de duración, dieron cuatro resultados principales:

A pesar de los concentraciones altas de nitrógeno se produce un tratamiento biológico estable del agua negra y amarilla incluyendo una nitrificación estable es posible.

También para esta parte de las aguas residuales el olor fue quitado simplemente por tratamiento biológico.

Entre todas las técnicas, que se probaron en estas investigaciones, solo el uso de ozono así como el tratamiento de irradiación UV-C (incluido el longitud de onda de 185 nm) tuvieron efecto en la eliminación del color.

El control de gérmenes demostró que las necesidades higiénicas son satisfechas totalmente por las técnicas seleccionadas para la purificación.

Una encuesta interna condujo a muy buenos resultados con respecto a la aceptación de usuario de los sistemas.

Las ventajas económicas fueron investigadas por una comparación de costes de la circulación de la agua negra con combinaciones de dos diversos sistemas para la purificación del agua gris por un lado y el sistema convencional de la depuradora por otro lado.

Finalmente se enumeran las posibilidades de las optimizaciones futuras del sistema así como los indicadores para la ampliación gradual y los ajustes relacionados del sistema.

Table of Contents

<i>Abstract</i>	II
<i>Table of Contents</i>	IV
<i>List of Tables</i>	VII
<i>List of Figures</i>	X
<i>List of Abbreviations</i>	XIII
Arabic Characters	XIII
Greek Characters	XIV
Indices.....	XIV
1 Introduction	1
2 Objectives of this Work	3
3 Background and Basics	4
3.1 Yellow Water	4
3.1.1 Chemical Composition	6
3.1.2 Technical Precipitation and Kidney Stones	6
3.1.3 Dyes of Fresh Urine	7
3.2 Brown Water	8
3.2.1 Chemical Composition	9
3.2.2 Dyes of Faeces	9
3.3 Black Water	10
3.4 Problematic Substances in Black Water Respectively its Source Separated Flows	10
3.4.1 Organic Micro Pollutants.....	10
3.4.2 Further Pollutants.....	12
3.5 Grey Water	13
3.6 Green Water – Residues of Cooking.....	14
3.7 White Water.....	14
3.8 Optical Perception of Colours	14
3.8.1 General Aspects	15
3.8.2 Measurement of Colours	16
3.8.3 Optical Perception and Measurement of Yellow Water	17
3.9 Concepts for Domestic Waste Water	19
3.9.1 End-of-Pipe-Technology	19
3.9.2 Innovative Sanitary Concepts.....	20
3.9.3 Comparison of these Concept Approaches	23
4 Black Water Loop – Idea of the System and Combination with Grey Water Loop	27
5 Material and Methods of Analysis	29
5.1 Chemical Analysis.....	29
5.2 Further Measurements and Analytic Methods.....	30
6 Lab Scale Tests	31
6.1 Biological Treatment.....	31
6.1.1 Description and Results.....	31
6.1.2 Interpretation and Conclusions	33

6.2	Storage and Deposition Tests	33
6.2.1	Description and Results	33
6.2.2	Interpretation and Conclusions	34
6.3	Decolourisation Tests	34
6.3.1	Screening of Suitable Technologies	34
6.3.2	Tests with UV Emitters not Including 185 nm	35
6.3.2.1	Description and Results	35
6.3.2.2	Interpretation and Conclusions	36
6.3.3	Tests with UV Emitters Including 185 nm	36
6.3.3.1	Description and Results	36
6.3.3.2	Interpretation and Conclusions	40
6.3.4	Experiments with Ozone	40
6.3.4.1	Batch Tests	41
6.3.4.1.1	Description and Results [Gulyas, H. et al., 2004]	41
6.3.4.1.2	Interpretation and Conclusions	41
6.3.4.2	Experiments with Continuous Flow	41
6.3.4.2.1	Description and Results	42
6.3.4.2.2	Interpretation and Conclusions	45
6.4	Systematic Precipitation respective Crystallisation	45
6.5	Overall Interpretation of Lab Scale Tests	46
7	<i>Experiments with Pilot Plant</i>	<i>48</i>
7.1	Collection of Source Separated Flows	48
7.2	Solid Separation	50
7.2.1	Description and Results	50
7.2.2	Interpretation and Conclusions	51
7.3	Volume Regulation and Ureolysis	51
7.3.1	Description and Results	51
7.3.2	Interpretation and Conclusions	52
7.4	Precipitation respective Crystallisation and pH-Adjustment	53
7.4.1	Description and Results	54
7.4.2	Interpretation and Conclusions	54
7.5	Biological Treatment and Membrane Filtration	55
7.5.1	Description and Results	55
7.5.2	Interpretation and Conclusions	58
7.6	Decolourisation and Disinfection	61
7.6.1	Description and Results	62
7.6.2	Interpretation, Conclusions, and Outlook	66
7.7	Control System and Program	68
7.8	Acceptance of this System at the AWW Institute	68
7.9	Overall Interpretation of Tests with the Pilot Plant	71
8	<i>System Variations and Basic Data for Design</i>	<i>72</i>
8.1	Applicability of Existing Plant	72
8.2	Possibilities for Improvements and Basic Data for Design of a Full Scale Plant	74
8.3	Risks of Application	78
8.4	Useful Combinations with other Techniques	81
9	<i>Cost Comparison Analysis</i>	<i>84</i>
9.1	Compared Systems and Initial Values	84
9.2	General Equations	89
9.3	Evaluation of Cost Comparison for the Application in Hotels	93
9.3.1	Comparison for Initial Values	93

9.3.2	Sensitivity Investigations Regarding Several Variables	94
9.3.3	Results of Comparison for Application in Hotels	99
9.4	Evaluation of Cost Comparison for the Application in Office Buildings	100
9.4.1	Comparison for Initial Values	100
9.4.2	Sensitivity Investigations Regarding Several Variables	101
9.4.3	Results of Comparison for Application in Office Buildings	106
9.5	Evaluation of Cost Comparison for the Application in Residential Buildings	107
9.5.1	Comparison for Initial Values	107
9.5.2	Sensitivity Investigations Regarding Several Variables	108
9.5.3	Results of Comparison for Application in a Residential Building	113
9.6	Conclusions of Cost Comparison Analysis	114
10	<i>Conclusions</i>	117
11	<i>Outlook</i>	120
12	<i>References</i>	121
13	<i>List of Catchwords</i>	136
14	<i>Appendix</i>	137
14.1	Data of Laboratory Scale Experiments	137
14.2	Design Values	140
14.3	Data of Cost Comparison Analysis	142

List of Tables

Table 3-1: Physical data of urine	4
Table 3-2: Weighted average of daily urine amount per person	5
Table 3-3: Measurements of pH and conductivity in fresh urine	5
Table 3-4: Typical nutrient loads of urine from adults	6
Table 3-5: Basic data concerning faeces	8
Table 3-6: Data on brown water compositions	9
Table 3-7: Metals in urine and faeces, according to [Wissenschaftliche Tabellen Geigy, 1977]	12
Table 3-8: Typical composition of grey water in Germany, according to [fbr H 201 - Grauwasser- Recycling, 2005]	13
Table 3-9: Microbiological contamination of grey water, according to [fbr H 201 - Grauwasser- Recycling, 2005]	13
Table 3-10: Main points of comparison between the end-of-pipe technique and innovative sanitation systems.....	23
Table 6-1: Ozone respective energy demand for decolourisation.....	42
Table 6-2: Energy demand for the complete decolourisation per percent of urine content of the sample	47
Table 7-1: Technical description of membrane system.....	56
Table 7-2: Results of microbiological analysis	65
Table 7-3: Listing of relevant microbiological guidelines and regulations	67
Table 7-4: Reasons not to use or to use the toilet/urinal	69
Table 8-1: Possible technical risks resulting from the use of the black water loop and associated countermeasures – part 1	79
Table 8-2: Possible technical risks resulting from the use of the black water loop and associated countermeasures – part 2	80
Table 8-3: Possible non technical risks resulting from the use of the black water loop and associated countermeasures	81
Table 9-1: Compared systems	85
Table 9-2: Explanations on abbreviations used in figure 9-1	86
Table 9-3: Explanations on abbreviations used in figure 9-2	87
Table 9-4: Explanations on abbreviations used in figure 9-3	88
Table 9-5: Amounts and compositions of the grey and black water streams	89
Table 9-6: Energy demand for conventional waste water purification and average concentrations according to [Dockhorn, T., 2006].....	91
Table 9-7: Initial values of factors for sensitivity analysis.....	92
Table 9-8: Energy demand of compared system combinations for the application on a hotel	114
Table 9-9: Energy demand of compared system combinations for the application on an office building	115
Table 9-10: Energy demand of compared system combinations for the application on a residential building.....	116
Table 10-1: Energy demand for the complete decolourisation per percent of urine content	118
Table 10-2: Concentrations of germs found during three series of measurement in purified liquid from the pilot plant taken subsequent the ultrafiltration prior respective subsequent UV treatment ...	118
Table 14-1: Assumed grey water generation in the hotel, the residential respective the office building	142
Table 14-2: Specific size of volume regulation tanks for grey water.....	144
Table 14-3: Fertilizer and compost prices and energy demand for production	144
Table 14-4: Expected operating periods for selected components	145
Table 14-5: Cost comparison of possible chemicals for addition in the precipitation unit	

(precipitation/crystallisation and pH regulation).....	146
Table 14-6: Invest and operating costs of calculated elements of the end-of-pipe system.....	146
Table 14-7: Invest and operating costs of calculated elements of the black water loop system (part 1)	147
Table 14-8: Invest and operating costs of calculated elements of the black water loop system (part 2)	148
Table 14-9: Invest and operating costs of calculated elements of the black water loop system (part 3)	149
Table 14-10: Invest and operating costs of calculated elements of the black water loop system (part 4)	150
Table 14-11: Invest and operating costs of calculated elements of the black water loop system (part 5)	151
Table 14-12: Invest and operating costs of calculated elements of the black water loop system (part 6)	152
Table 14-13: Invest and operating costs of calculated elements of the black water loop system (part 7)	153
Table 14-14: Invest and operating costs of calculated elements of the grey water loop system (part 1)	154
Table 14-15: Invest and operating costs of calculated elements of the grey water loop system (part 2)	155
Table 14-16: Invest and operating costs of calculated elements of the grey water loop system (part 3)	156
Table 14-17: Invest and operating costs of calculated elements of the grey water loop system (part 4)	157
Table 14-18: Invest and operating costs of calculated elements of the grey water loop system (part 5)	158
Table 14-19: Invest and operating costs of calculated elements of the grey water loop system (part 6)	159
Table 14-20: Invest and operating costs of calculated elements of the grey water loop system (part 7)	160
Table 14-21: Invest and operating costs of calculated elements of the service water system (part 1)	161
Table 14-22: Invest and operating costs of calculated elements of the service water system (part 2)	162
Table 14-23: Invest and operating costs of calculated elements of the service water system (part 4)	163
Table 14-24: Invest and operating costs of calculated elements of the service water system (part 5)	164
Table 14-25: Invest and operating costs of calculated elements of the service water system (part 6)	165
Table 14-26: Total project costs and annual costs for an application in a hotel for the initial values of the variables	165
Table 14-27: Total project costs and annual costs for an application in an office building for the initial values of the variables	166
Table 14-28: Total project costs and annual costs for an application in a residential building for the initial values of the variables	166
Table 14-29: Intersection points resulting from the sensitivity analysis regarding varying rates of interest for application of the systems in a hotel.....	167
Table 14-30: Intersection point resulting from the sensitivity analysis regarding varying drinking water fees for application of the systems in a hotel	167
Table 14-31: Intersection points resulting from the sensitivity analysis regarding varying waste water fees for application of the systems in a hotel	167
Table 14-32: Intersection points resulting from the sensitivity analysis regarding varying drinking and waste water fees for application of the systems in a hotel.....	167
Table 14-33: Intersection points resulting from the sensitivity analysis regarding a varying energy price (constant water fees) for application of the systems in a hotel	168

Table 14-34: Intersection points resulting from the sensitivity analysis regarding a varying energy price with direct effect on water fees and contamination related water fees for application of the systems in a hotel	168
Table 14-35: Intersection points resulting from the sensitivity analysis regarding varying energy, drinking water and waste water fees for application of the systems in a hotel	168
Table 14-36: Intersection points resulting from the sensitivity analysis regarding a varying surcharge for engineering etc for application of the systems in a hotel	168
Table 14-37: Intersection points resulting from the sensitivity analysis regarding varying rates of interest for application of the systems in an office building.....	169
Table 14-38: Intersection point resulting from the sensitivity analysis regarding varying drinking water fees for application of the systems in an office building	169
Table 14-39: Intersection points resulting from the sensitivity analysis regarding varying waste water fees for application of the systems in an office building	169
Table 14-40: Intersection points resulting from the sensitivity analysis regarding varying drinking and waste water fees for application of the systems in an office building.....	169
Table 14-41: Intersection points resulting from the sensitivity analysis regarding a varying energy price (constant water fees) for application of the systems in an office building	170
Table 14-42: Intersection points resulting from the sensitivity analysis regarding a varying energy price with direct effect on water fees and contamination related water fees for application of the systems in an office building	170
Table 14-43: Intersection points resulting from the sensitivity analysis regarding varying energy, drinking water and waste water fees for application of the systems in an office building	170
Table 14-44: Intersection points resulting from the sensitivity analysis regarding a varying surcharge for engineering etc for application of the systems in an office building.....	170
Table 14-45: Intersection points resulting from the sensitivity analysis regarding varying rates of interest for application of the systems in a residential building	171
Table 14-46: Intersection point resulting from the sensitivity analysis regarding varying drinking water fees for application of the systems in a residential building	171
Table 14-47: Intersection points resulting from the sensitivity analysis regarding varying waste water fees for application of the systems in a residential building	171
Table 14-48: Intersection points resulting from the sensitivity analysis regarding varying drinking and waste water fees for application of the systems in a residential building	171
Table 14-49: Intersection points resulting from the sensitivity analysis regarding a varying energy price (constant water fees) for application of the systems in a residential building	172
Table 14-50: Intersection points resulting from the sensitivity analysis regarding a varying energy price with direct effect on water fees and contamination related water fees for application of the systems in a residential building	172
Table 14-51: Intersection points resulting from the sensitivity analysis regarding varying energy, drinking water and waste water fees for application of the systems in a residential building.....	172
Table 14-52: Intersection points resulting from the sensitivity analysis regarding a varying surcharge for engineering etc for application of the systems in a residential building.....	172

List of Figures

Figure 3-1: Colours and their wavelength range, values according to [Welsch, N. and Liebmann, C. C., 2003].....	15
Figure 3-2: 2° and 10° observer.....	16
Figure 3-3: Spectra of decolorized liquid from black water loop, fresh urine, stored urine, and drinking water.....	18
Figure 3-4: Spectra of different coloured liquids [Tettenborn, F., 2003].....	18
Figure 3-5: Nutrient contents of domestic waste water flows.....	21
Figure 4-1: Black and grey water loop scheme.....	28
Figure 6-1: Set-up of biological treatment pre-tests – activated sludge system.....	32
Figure 6-2: Set-up of biological treatment pre-tests – fixed bed system.....	32
Figure 6-3: System set-up of UV-C pre-tests (including 185 nm).....	36
Figure 6-4: Energy demand for visibly complete decolourisation (C* values between 0.74 and 3.83).....	37
Figure 6-5: Exemplary C* values during UV treatment with given rate of recirculation of the liquid.....	37
Figure 6-6: C* values of different samples at beginning of treatment.....	38
Figure 6-7: Influence of pump velocity respective recirculation rate on decolourisation.....	39
Figure 6-8: C* values corresponding with a subjective colourlessness subsequent UV treatment.....	39
Figure 6-9: C* values compared to energy input during ozone treatment (100% and 40% samples untreated, 29% samples biologically pre-treated).....	42
Figure 6-10: Energy input for colourless status with recolouring (100% and 40% samples untreated, 29% samples biologically pre-treated).....	43
Figure 6-11: Energy input for colourless status without recolouring (40% sample untreated, 29% samples biologically pre-treated).....	44
Figure 6-12: C* values corresponding with a subjective colourlessness after ozone treatment.....	44
Figure 7-1: System sketch of the used pilot scale black water loop.....	48
Figure 7-2: Dry matter of separated solids.....	50
Figure 7-3: pH in equalisation tank during experiment.....	52
Figure 7-4: Substances removed by the different membrane systems, Dalton: Numerical equivalent of the molecular weight [g/mol], figure according to [Abwasserreinigung mit Membrantechnik, 2003].....	55
Figure 7-5: Ammonium, nitrite, and nitrate nitrogen concentrations in the liquid of the biological treatment unit.....	57
Figure 7-6: Magnesium and total phosphorous concentrations in the liquid of the biological treatment unit.....	58
Figure 7-7: Oxygen content and temperature of liquid in the of biological treatment unit.....	59
Figure 7-8: System sketch of UV treatment step.....	62
Figure 7-9: C* values of liquid subsequent to the UV treatment and limit of colourlessness.....	63
Figure 7-10: C* values and the specific energy input.....	64
Figure 7-11: C* values and tap water additions.....	65
Figure 7-12: Control system of the pilot plant.....	68
Figure 7-13: Frequency of toilet and urinal use.....	69
Figure 7-14: Acceptance of a black water respective grey water loop implementation in the own house.....	70
Figure 8-1: System sketch of improved pilot plant with nanofiltration – version I.....	73
Figure 8-2: System sketch of improved pilot plant with DIACHEM® electrode – version II.....	74
Figure 9-1: System configuration of the black water loop system for cost comparison analysis.....	85
Figure 9-2: System configuration of the grey water loop system for cost comparison analysis.....	86
Figure 9-3: System configuration of the grey water purification system for cost comparison analysis.....	87
Figure 9-4: Total project costs for a hotel calculated by initial values for variables and standard fees for.....	

the conventional system	93
Figure 9-5: Total project costs for a hotel calculated by initial values for variables and waste water fees according to contaminations for the conventional system	94
Figure 9-6: Results of sensitivity investigations on varying rates of interest on the application of the systems in a hotel	95
Figure 9-7: Results of sensitivity investigations on varying drinking water fees on the application of the systems in a hotel	95
Figure 9-8: Results of sensitivity investigations on varying waste water fees on the application of the systems in a hotel	96
Figure 9-9: Results of sensitivity investigations on varying drinking and waste water fees on the application of the systems in a hotel	96
Figure 9-10: Results of sensitivity investigations on varying energy prices and constant water fees on the application of the systems in a hotel.....	97
Figure 9-11: Results of sensitivity investigations on varying energy prices respecting the direct effect on the water fees and contamination related waste water fees on the application of the systems in a hotel.....	98
Figure 9-12: Results of sensitivity investigations on varying energy prices and drinking water and waste water fees on the application of the systems in a hotel	98
Figure 9-13: Results of sensitivity investigations on varying the surcharge for engineering etc on the application of the systems in a hotel	99
Figure 9-14: Total project costs for an office building calculated by initial values for variables and standard fees for the conventional system	100
Figure 9-15: Total project costs for an office building calculated by initial values for variables and waste water fees according to contaminations for the conventional system	101
Figure 9-16: Results of sensitivity investigations on varying rates of interest on the application of the systems in an office building	102
Figure 9-17: Results of sensitivity investigations on varying drinking water fees on the application of the systems in an office building.....	102
Figure 9-18: Results of sensitivity investigations on varying waste water fees on the application of the systems in an office building	103
Figure 9-19: Results of sensitivity investigations on varying drinking and waste water fees on the application of the systems in an office building	104
Figure 9-20: Results of sensitivity investigations on varying energy prices and constant water fees on the application of the systems in an office building.....	104
Figure 9-21: Results of sensitivity investigations on varying energy prices respecting the direct effect on the water fees and contamination related waste water fees on the application of the systems in an office building.....	105
Figure 9-22: Results of sensitivity investigations on varying energy prices and drinking water and waste water fees on the application of the systems in an office building	105
Figure 9-23: Results of sensitivity investigations on varying the surcharge for engineering etc on the application of the systems in an office building	106
Figure 9-24: Total project costs for a residential building calculated by initial values for variables and standard fees for the conventional system	107
Figure 9-25: Total project costs for a residential building calculated by initial values for variables and waste water fees according to contaminations for the conventional system	108
Figure 9-26: Results of sensitivity investigations on varying rates of interest on the application of the systems in a residential building	109
Figure 9-27: Results of sensitivity investigations on varying drinking water fees on the application of the systems in a residential building	109
Figure 9-28: Results of sensitivity investigations on varying waste water fees on the application of the systems in a residential building	110

Figure 9-29: Results of sensitivity investigations on varying drinking and waste water fees on the application of the systems in a residential building	110
Figure 9-30: Results of sensitivity investigations on varying energy prices and constant water fees on the application of the systems in a residential building	111
Figure 9-31: Results of sensitivity investigations on varying energy prices respecting the direct effect on the water fees and contamination related waste water fees on the application of the systems in a residential building	112
Figure 9-32: Results of sensitivity investigations on varying energy prices and drinking water and waste water fees on the application of the systems in a residential building	112
Figure 9-33: Results of sensitivity investigations on varying the surcharge for engineering etc on the application of the systems in a residential building	113
Figure 14-1: C* values of investigated samples at beginning of UV treatment	137
Figure 14-2: C* values of urine samples during UV-treatment with given pump velocity and rate of recirculation	137
Figure 14-3: C* values of samples from black water loop during UV-treatment with given pump velocity and rate of recirculation	138
Figure 14-4: C* values of investigated samples at beginning of ozone treatment	138
Figure 14-5: For ozonation necessary energy input for colourless status of biologically pre-treated liquids	139
Figure 14-6: Amount curve estimation for black water for a residential building, supposition: the complete daily black water disposal takes place in the house, 25 l/inhabitant*d	140
Figure 14-7: Amount curve estimation for black water for an office building, supposition: 2 employees count as one full inhabitants equivalent [Arbeitsblatt ATV-A 122, 1991], 12.5 l/employee*d	140
Figure 14-8: Amount curve estimation for black water for a hotel derived from [fbr H 201 - Grauwasser-Recycling, 2005], supposition: 1 bed counts as an equivalent of two full inhabitants [Arbeitsblatt ATV-A 122, 1991], 50 l/bed*d.....	141
Figure 14-9: Amount curve estimation for the grey water stream for a residential building, supposition: The daily grey water generation is about 70 l/inhabitant, see table 9-5	143
Figure 14-10: Amount curve estimation for the grey water stream for an office building, supposition: 2 employees count as one full inhabitants equivalent [Arbeitsblatt ATV-A 122, 1991], the daily grey water generation is about 35 l/employee, see table 9-5	143
Figure 14-11: Amount curve estimation for the grey water stream for a hotel, supposition: 1 bed counts as an equivalent of two full inhabitants [Arbeitsblatt ATV-A 122, 1991], the daily grey water generation is about 140 l/bed, see table 9-5	144

List of Abbreviations

AWW Institute	Institute of Wastewater Management and Water Protection of the Hamburg University of Technology
BOD	biological oxygen demand
bw	black water
BWL	black water loop
cfu	colony forming units
CIE	Commission Internationale de l'Eclairage
CIELAB	the L* a* b* colour space of the CIE, see chapter 3.8
DIN	Deutsches Institut für Normung e.V., German standards
DM	dry matter, dry solid matter
DWA	Deutsche Vereinigung für Wasserwirtschaft, Abwasser und Abfall e.V.
EcoSan	Ecological Sanitation
EcoSanRes	Ecological Sanitation Research
EoP	end of pipe system
EU	European Union
GWL	Grey water loop (drinking water quality), see figure 9-2
GWP	Grey water purification system (service water quality), see figure 9-3
HAP	hydroxyapatite
MAP	magnesium ammonium phosphate (hexahydrate), also struvite
mbr	membrane bioreactor
MPP	magnesium potassium phosphate
OCP	octacalcium phosphate
p	person
rpm	rounds per minute
srt	solid retention time
TC	total carbon
TIC	total inorganic carbon
TKN	total Kjeldahl nitrogen
TN	total nitrogen
TOC	total organic carbon
TS	total solids
TUHH	Hamburg University of Technology
UV-A	ultraviolet light in the range between 320 and 400 nm
UV-B	ultraviolet light in the range between 280 and 320 nm
UV-C	ultraviolet light in the range between 100 and 280 nm
WHO	World Health Organization
wwtp	waste water treatment plant

Arabic Characters

a*	coordinate 1 in the CIE colour space (CIELAB), see chapter 3.8
b*	coordinate 2 in the CIE colour space (CIELAB) , see chapter 3.8
B _{A,BOD}	design surface load [g/m ² *d] for carbon degradation by a submerged fixed bed according to [Bever, J. et al., 2002]
B _{A,TKN}	design surface load [g/m ² *d] for ammonium oxidation by a submerged fixed bed according to [Bever, J. et al., 2002]

$B_{d,BOD}$	daily freight of biological oxygen demand [kg BOD/d]
$B_{d,TKN}$	daily freight of total Kjeldahl nitrogen [kg TKN/d]
C^* respective C^*_{ab}	colourfulness according to German standard DIN 5033, part 3
c_s	saturation content of oxygen [mg/l]
c_x	oxygen concentration [mg/l]
F_T	factor for the temperature influence on the endogenous respiration
h_{ab}	hue angle in the CIELAB colour space, see chapter 3.8
k	factor according to German standard DIN 5033, part 3
L^*	brightness according to German standard DIN 5033, part 3
OC	oxygen content according to [Arbeitsblatt ATV-DVWK-A 131, 2000] formula 5-28
S_λ	function of radiation according to German standard DIN 5033 part 1
t_{DM}	retention time of sludge in the biological treatment unit
X_{10}	colour value according to German standard DIN 5033, part 3
Y_{10}	colour value according to German standard DIN 5033, part 3
Z_{10}	colour value according to German standard DIN 5033, part 3

Greek Characters

$\Delta\lambda$	interval of measurements with the photometer
α	oxygen transfer coefficient
φ_λ	stimulus function of colours according to German standard DIN 5033 part 1

Indices

A	surface
C	carbon
d	daily
i	counter (1, 2, 3...n)
s	saturation
T	temperature in °C
x	oxygen
λ	wavelength

1 Introduction

The increasing pressure to save resources and to protect the environment leads to the necessity to develop of new types of waste water treatment systems. As the conventional systems are mainly focussing on the waste water purification, these technologies are not optimised for recycling of the resources contained in the waste water. Technologies for a reuse of water as well as of waste water contents like these are well known for industrial applications are very rare for the application on domestic waste water. But regarding nutrients and carbon the domestic waste water contains relevant amounts of partially limited resources. Furthermore limitations in availability of clean water increase the ecologic and economic need for water reuse. A system which allows the recycling of the nutrients and the carbonaceous compounds as well as the full reuse of the water without down cycling effect, will cover the above mentioned needs. The domestic waste water consists of two main partial flows. The waste water from toilets is called black water (see chapter 3.3). The remaining water stream (except rain water) is called grey water (see chapter 3.5). To create such an above mentioned closed loop system for water, the development of two (separate) treatment systems for these two partial flows seem to be suitable.

Scopes of this work are theoretical as well as practical investigations regarding a black water reuse as flushing water for toilets. Basis of these investigations was simply the idea to develop a closed loop system with reuse of water and contained nutrients. Determination of necessary treatment steps as well as the selection and testing of technical components are part of this work.

A main objective of this work is to prove the technical feasibility of this attempt, to give first indications for dimensioning and energy demand and also to give possible options for further improvements. Additionally, risks of application and related counter measures are listed. To get a first impression of the acceptance of this technique, an anonymous investigation among the employees of the AWW Institute has been carried out. Furthermore a cost-comparison analysis provides knowledge on economic benefits of concepts including the black water loop. Overall, these investigations give an overview to support planning of full scale plants and to give initial values for the next steps of development to reach a market-ready product.

The technical principles of the used components and the materials and methods for measurements and evaluation base on a very wide field of technical and scientific basic knowledge. Hence, a full description of these basics is not possible in this work. If necessary, the corresponding technical literatures need to be consulted to get additional input on special topics. The described basic information is just a listing of important facts, which gives a very rough overview of the waste water concepts and the characteristics of partial flows. As the colour removal and colour measurement are very important fields for research on the black water loop and as these are not common topics among environmental engineering experts, the measurement as well as the formulae for evaluation are described more in detail.

In chapter 2 the objectives of this work are listed. The chapters 3 and 4 give the above-mentioned introduction into important fields of basic knowledge respective into the idea of the investigated process concept. The experiments in lab and pilot scale are described in the chapters 6 and 7. Material and methods are also mainly described here, but as the number of different experimental set-ups is too big as a collective description would be useful for this thesis, these can be found directly in the descriptions of the experiments. General descriptions regarding chemical analytics and further often used principles of measurement are listed in chapter 5. Scope of the lab scale investigations of chapter 6 is to find out more about suitability of applied technologies and possibilities for improvement, while the tests with the pilot plant (described in chapter 7) mainly are carried out to demonstrate the

technical feasibility. In chapter 8 the results of the experiments are combined with common design rules of the waste water engineering and are further developed as basic data for further research as well as the application for design of full scale treatment units. Risks of application and related counter measures are also listed in this chapter as well as technical options for system modifications and useful improvements for the further application of the pilot plant. The calculations of chapter 9 complete the investigations by a cost comparison calculation for a hotel, an office building and a residential building. In these calculations the black water loop is combined with two different techniques for grey water purification (1. grey water loop ? purification up to drinking water quality (feasibility not yet proved by experiments/implementations), 2. common grey water purification ? for reuse as service water) respective an improved end-of-pipe system. As reference for the comparison the costs for the systems of these virtual buildings are additionally calculated for an improved end-of-pipe system for the whole waste water stream. The improvements of the conventional end-of-pipe system are the generation of compost respective fertilizer, which are also products of the black water loop. These adaptations of the conventional system are necessary to ensure the equality of benefits for all compared system combinations (prerequisite of cost comparison calculations [Leitlinien zur Durchführung dynamischer Kostenvergleichsrechnungen (KVR-Leitlinien), 1998]). The overall conclusion and the outlook are given in the chapters 10 respectively 11.

2 Objectives of this Work

The general scope of this thesis is to develop and investigate basics for a system, which meets all the purification needs of the black water loop idea. The experiments were conducted to prove the technical feasibility of the concept and to learn about advantages and disadvantages of the different applied technologies. This work covers the whole purification process of the black water loop except the precipitation respective crystallisation unit.

To ensure the usability of the water as flush liquid, odour and colour need to be removed as well as it is necessary to reduce the concentration of germs. To reach these main research objectives, techniques need to be tested and the applicability in the completed system (pilot plant) must be investigated.

For the separation of solids a technique for application in smaller units is in use. Further technical options for bigger plants can not be tested in the pilot plant, as the inflow is too limited. Treatment of faecal solids is subject of various dissertations in the Institute of Wastewater Management and Water Protection of the Hamburg University of Technology. As the vermicomposting as well as the treatment in anaerobic digesters are already investigated options for the further treatment of faecal matter [Behrendt, J. et al., 2006; Gajurel, D. R. et al., 2004; Jönsson, H., et al., 2004; Shalabi, M. et al., 2004; Shalabi, M., 2006; Wendland, C. and Otterpohl, R., 2007] these topics do not need to be examined in this work anymore.

During the tests on biological treatment inhibition by e.g. high salt concentrations or products of biological or chemical reactions might appear. Experiments must prove the long-term applicability of a stable biological treatment (effect of increasing concentrations by closed loop). The investigations on this issue deal with the adaptation of the biomass, generation of adapted biomass for further plants and technical aspects of the biological treatment.

The results of this work list options for further improvement of this technique and can be used as basis to estimate the further research demand for the development of a mature, marketable product. Next to the technical aspects also the economic aspects are investigated to prove the economic benefits of this technique for larger buildings. In some aspects the input data had to be estimated for this. For more detailed calculations further investigations on optimisation and a real project (detailed design) are necessary premises.

The system developed in this thesis is a high-tech solution for treatment of black water. The application of this technique depends on the availability of sufficient technical support by maintenance companies as well as the supervision of this technique by trained caretakers. Suitable solutions for low-income areas are described e.g. on the EcoSanRes homepage (www.ecosanres.org) and in further literature as [Gajurel, D. R., 2003; Shalabi, M., 2006].

3 Background and Basics

This chapter gives a brief summary of topics with high relevance to this work. Basic knowledge on relevance and composition of different domestic waste water streams is given, as well as on dyes in brown respective yellow water and their optical perception by the human eyes. These dyes and the way of perception are important aspects for the black water loop, as just a liquid accounted as colour free, will reach the necessary acceptance. Further the aspect of micro pollutants and their possible appearance are discussed. Finally the main aspects of conventional waste water management and innovative sanitary concepts are listed and compared.

The research of this thesis deals with such a high number of scientific working fields and technologies, that these can not all be described within the textual limitations of this kind of thesis. Hence, for detailed information regarding these subjects references are given. For issues of minor relevance and technical background information regarding used technologies (UV, ozone, membranes, biological degradation, nitrification, etc.) additional specific technical literature may be useful.

3.1 Yellow Water

Yellow water is the technical term for the partial waste water stream containing diluted (flushing water) or undiluted urine. A new definition of the DWA, which will be published soon, will limit the meaning of yellow water to diluted urine [Tettenborn, F., 2007]. Engineering research on yellow water is a rather new approach, so existing data mainly derives from the medical research and therefore deals with undiluted urine. Furthermore, values for diluted urine always depend on the rate of dilution. So in these chapters concentrations are only given for pure urine and all data display typical values for adults.

Production of urine appears in the kidneys, where approximately 1800 l of blood are filtered every day. As final result of this approximately 1.2 l of urine are produced from the filter residues. Reasons for urine generation of the human body are the regulation of the acid-base and water-electrolyte balance as well as to excrete water, catabolic end products (e.g. urea, uric acid, ammonium, phosphate and sulphate), and foreign matters (e.g. pharmaceuticals and poisons). [Schmidt, R. F. and Thews, G., 2005]

Table 3-1: Physical data of urine

[1]: [Wissenschaftliche Tabellen Geigy, 1977], [2]: [Hofstetter, A. G. and Eisenberger, F., 1996], [3]: [Jocham, D. and Miller, K., 1994], [4]: [Alken, P. and Walz, P. H., 1998], [5]: [Alken, P., et al., 1992], [6]: [Hautmann, R. E. and Huland, H., 1997], [7]: [Wetterauer, U., et al., 1995]

pH	4.5 - 8.2	approx. 6.8	4.4 - 7.5	5 - 7	5 - 6		4.5 - 8
Specific weight* [g/l]	1015 (1001-1028)	1001 - 1035	1015 - 1024	1001 - 1040	1001 - 1040	1003 - 1030	1001 - 1030
Amount [ml/d]	980 - 1360 (320 - 2690) > 90 a: 853 (275 - 2400)	1000 - 1500	1000 - 1500				
Reference	[1]	[2]	[3]	[4]	[5]	[6]	[7]

* conversion of relative density to specific weight by use of assumption:
specific weight of water is 1.0 kg/l

Values of different surveys published in [Wissenschaftliche Tabellen Geigy, 1977] are used for following calculations of common urine amounts. The calculation of the weighted average amount shown in table 3-2 is weighted regarding the number of test persons.

Table 3-2: Weighted average of daily urine amount per person

Average of each test	Number of test persons
1360 ml/d	33
1130 ml/d	39
980 ml/d	30
Weighted average	
1160 ml/d	

From medical point of view daily amounts of 500 to 2000 ml are normal. Cases of more than 2000 ml/d are called polyurie. In the other extreme oliguria means a production of less than 500 ml and anurie of less than 100 ml (total anurie 0 ml) urine per day. This may be relevant for volume sensitive techniques for example in buildings for senior citizens (high fraction of persons with low urine generation).

During pre-tests measurements regarding pH and conductivity of fresh, undiluted urine samples of single persons were made. Results are listed in table 3-3.

Table 3-3: Measurements of pH and conductivity in fresh urine

Sample	1	2	3	4	5	6	7	8	9	Average	Minimum	Maximum
pH [-]	5.64	7.06	7.58	7.81	6.63	6.68	5.79	7.06	-	6.8	5.6	7.8
Conductivity [mS / cm]	9.2	16.0	25.9	26.2	17.5	10.5	12.6	22.0	24.8	18.3	9.2	26.2

Fresh urine has a light odour. It differs corresponding to water excretion and food. E.g. coffee, garlic, or asparagus can change it significant. [Wissenschaftliche Tabellen Geigy, 1977]

Urine normally is sterile inside the urine bladder, but in the lower parts of urinary tract contamination by micro organisms occurs. Thus, a content of 10^3 organisms per millilitre is possible for a healthy person. These organisms are normally harmless. Only in cases of an infection of the individual, disease causing organisms occur. [Schönning, C. and Stenström, T. A., 2004]

Pathogens transmitted by urine are not considered to constitute a health risk [Schönning, C., 2001]. Hygienic risks associated with the use of diverted urine are mainly result of cross-contamination by faeces. Separate storage is a common method for “treatment” of urine, because it is simple and cheap. [Jönsson, H., et al., 2004]

A separate gathering of yellow water is possible by use of no-mix toilets or urinals. One special no-mix toilet (produced by Roediger Vakuum- und Haustechnik GmbH, Germany) prevents dilution of separated yellow water with flushing water by means of a valve. Another possibility for separation of undiluted urine is the use of urinals without flushing (protection against odours by a siphon or membrane).

A detailed description of colour and vision of urine can be found in chapter 3.8.3.

3.1.1 Chemical Composition

Urine is a very complex substance and varies in its composition. A very detailed description of the main chemical components is given in [Wissenschaftliche Tabellen Geigy, 1977]. This chapter lists important components with relevance for the further investigations and conclusions of this work. Formation of urine differs from person to person and one region to another. Main aspects for this are amount and kind of alimentation. Further aspects are drugs, climatic conditions, and gender. A list with typical nutrient loads of adults is given in table 3-4.

Table 3-4: Typical nutrient loads of urine from adults

Total nitrogen (TN) [g/d]	9.19 - 11.5	7 - 25	7.1 (5.2 - 9.6)	
Phosphorous (P) [g/d]	0.8 - 2.0	0.5 - 1.5	0.8 (0.5 - 1.1)	1.0
Sulfur (S) [g/d]	1.32 (1.24 - 1.49)			
Potassium (K) [g/d]	2.7 (1.6 - 3.9)	1.3 - 4.0	3.0 (2.5 - 3.6)	2.5
Calcium (Ca) [g/d]	0.182 - 0.238	0.25 - 0.3		
Magnesium (Mg) [g/d]	0.107 - 0.131	0.1 - 0.2		
Reference	[1]	[2]	[3]	[4]

[1]: [Wissenschaftliche Tabellen Geigy, 1977], [2]: [Jocham, D. and Miller, K., 1994], [3]: [Jönsson, H. and Vinneras, B., 2004], [4]: [Wendler, D., 2005]

Urine of a healthy human normally does not contain proteins and sugar. Their appearance can be a sign for a disease.

Residues of water-soluble drugs mainly are excreted by urine (see chapter 3.4.1). Additionally, urine contains low amounts of metals (see chapter 3.4.2).

3.1.2 Technical Precipitation and Kidney Stones

The general aspects of technical and natural precipitation of urine (nephrolythiasis) are the same. Generation of a urinary calculus is a complex process. Events like super saturation, nucleation, crystallization, aggregation, growth, conversion, and dissolving appear at the same time or successively.

Crystals, respectively kidney stones, arise from (local) exceeding of the solubility. In an unsaturated solution no crystals are produced. With increasing saturation a metastable concentration can be reached. This allows the generation of crystals. A further increase of concentration leads to a supersaturated solution. Normally crystals will be generated in this case. [Jocham, D. and Miller, K., 1994] The here described chemical circumstances of urinary calculuses are part of the so called crystallization theory.

But in addition to this theory there is an effect of the so called inhibitors in the urine. In spite of a high concentration of lithogenic substances these inhibitors prevent the generation of urinary calculuses.

So far identified inhibitors are pyrophosphate, citrate, magnesium, glycosamine glycanes, heparin, and chondroitin sulphate. [Hofstetter, A. G. and Eisenberger, F., 1996; Jocham, D. and Miller, K., 1994]

Another theory, the matrix theory, bases on the fact that between 2 and 10% of stone material consists of organic amorphous compounds. They pervade the crystals like a frame. Possibly these organic matters are produced by the kidneys under pathogenic conditions. Subsequently salts adsorb on this basis structure. This theory affirms why with equate urine composition one kidney (because of pathogenic affection) can be preferred for the stone generation. [Jocham, D. and Miller, K., 1994] 100 years ago the risk for a man to come down with a urinary calculus was 20 times higher than for a woman. Possibly as consequence of the sexual equality today the risk is nearly the same. There are hints in the literature that one factor for the generation of stones is stress. Compared to manufacturers some statistical evaluations found a higher risk for clerks and university graduates. Additionally the risk is higher for members of a family with previous cases of stone generation although genetic causes in most cases can not be proved. [Jocham, D. and Miller, K., 1994]

Thus, generation of crystals in urine still is not completely investigated. These effects have (at least partially) to be considered to be relevant also in technical crystallization respective precipitation. The most common kind of stone consists of a combination of calcium oxalate monohydrate, calcium oxalate dehydrate, and apatite (22.4%). Calcium oxalate monohydrate (58.6 %, whewellit, $\text{CaC}_2\text{O}_4 \cdot \text{H}_2\text{O}$) and calcium oxalate dihydrate (13.8%, weddellit, $\text{CaC}_2\text{O}_4 \cdot 2 \text{H}_2\text{O}$) are the most common main components of urinary stones.

Which kind of stone is generated also depends on the pH value. Calcium oxalate stones are normally engendered in acidic urine. The most common stones under alkaline conditions are magnesium ammonium phosphate hexahydrate (MAP) combined with apatite (15.5%), MAP with apatite and calcium oxalate (3.2%) and pure MAP (0.3%, also called struvite, $\text{MgNH}_4\text{PO}_4 \cdot 6 \text{H}_2\text{O}$) [Wissenschaftliche Tabellen Geigy, 1977; Jocham, D. and Miller, K., 1994].

Studies concerning waste water systems with urine diversion show that MAP, octacalcium phosphate (OCP), and hydroxiapatite (HAP, $\text{Ca}_{10}(\text{PO}_4)_6(\text{OH})_2$) precipitates. As consequence of ureolysis (urea hydrolysis, $\text{NH}_2(\text{CO})\text{NH}_2 + 2\text{H}_2\text{O} \rightarrow \text{NH}_3 + \text{NH}_4^+ + \text{HCO}_3^-$) in these systems the pH increases. So these results agree with afore listed medical data concerning urinary calculuses at higher pH.

In these studies precipitation of struvite starts immediately as soon as supersaturation is reached. For a precipitation of noteworthy OCP crystals a high supersaturation is necessary. But OCP is only a precursor phase which slowly transforms into HAP, the final calcium phosphate mineral in urine. [Udert, K. M. et al., 2003b] The fraction of MAP increases compared to OCP with decreasing dilution with calcium containing water. These results of measurements fit well with findings of a computer based modelling of the precipitation process. [Udert, K. M. et al., 2003c]

MAP is a good product for a phosphate recycling system for waste water [Gethke, K. et al., 2005a], as it is a slow release fertilizer [Ueno, Y. and Fujii, M., 2001] and also a possible raw material for commercial fertilizer production [Giesen, A., 1999; Ueno, Y. and Fujii, M., 2001]. Some investigations concerning pilot and full scale plants for precipitation in streams of wastewater treatment systems already have been performed [Pinnekamp, J., 2003].

3.1.3 Dyes of Fresh Urine

Appraisal of urine colour was and partially still is an important examination method in medicine and therefore was investigated mainly by health specialists. A variation of the colour can be a hint for a disease or poisoning or result of intake of certain alimentations or pharmaceuticals. Next to normal

clear yellow brown, red, green, blue, or black coloration can appear. Furthermore, in normally clear urine a haze can occur. [Wissenschaftliche Tabellen Geigy, 1977; Hofstetter, A. G. and Eisenberger, F., 1996; Jocham, D. and Miller, K., 1994]

Normal yellow colour is caused by compounds of the group of urochrome. So far known examples are bilirubin, urobilin, and the group of porphyrine. [Wissenschaftliche Tabellen Geigy, 1977] These matters are products of heme degradation (part of red blood corpuscles). In the colon bilirubin is hydrolyzed. One product of this process is the colourless urobilinogen. Main contingent of it is transformed to red brown stercobilin and excreted with the faeces. A smaller amount is reabsorbed and transported to the kidneys where it attains into the urine. Only a part of the urobilinogen is transformed to the yellow urobilin, which causes the normal yellow colour of urine. [Tettenborn, F., 2003]

3.2 Brown Water

Brown water is the technical term for the toilet waste water minus the yellow water respective urine. It contains faeces, toilet paper (depending on anal cleansing) and in the case of water flushed toilets or wet anal cleaning even water. According to a new DWA definition just a dilution by water makes faeces become brown water [Tettenborn, F., 2007].

In some innovative sanitation concepts the collection of toilet paper happens in special buckets. In the following table several basic data on faeces are given. These values refer to undiluted faeces without toilet paper, because the main data basis for brown water respective faeces is medical literature and for medical requirements just measurements of undiluted material is applicable.

Table 3-5: Basic data concerning faeces

Reference	Amount [g/d]	TS [g/d]	Specific weight [kg/l]	pH	Number of defecations
[1]	124 (35 - 224)	21 - 34	< 1.0*	7.15	1/d
[2]	30 - 570				
[3]	35 - 250				3/week - 3/d
[4]	men: 107-142 (60 - 195) women: 55 (31 - 81)	men: 27 - 35 (15 - 47) women: 16 (11 - 25)			

[1] [Wissenschaftliche Tabellen Geigy, 1977], [2] [Buchmann, P., et al., 1998], [3] [Hansen, W. E., 1987], [4] [Caspary, W. F. and Stein, J., 1999]

Approximately 10 kg dry matter result from the yearly amount of about 50 kg faeces of one person [Heinonen-Tanski, H. and van Wijk-Sibesma, C., 2005].

Faeces are a very complex mixture of food residues, secretions of the intestinal tract, desquamated cells of the intestinal wall and parts of the gut flora.

The odour of faeces is caused by volatile products of the protein putrefaction [Wissenschaftliche Tabellen Geigy, 1977].

Brown water contains high amounts of possibly pathogenic germs (bacteria, viruses, parasitic protozoa, and helminths). Values of $800 \cdot 10^{12}$ ($100 \cdot 10^{12} - 2,200 \cdot 10^{12}$) bacteria per kg dry matter are listed in literature [Wissenschaftliche Tabellen Geigy, 1977]. For hygienic safety a germicidal treatment must take place before it can be applied or released to the environment [Schönning, C. and Stenström, T. A., 2004]. For reuse of waste water for irrigation purposes in agriculture limiting values of $10^3 - 10^5$ faecal coliforms per 100 ml and 0.1 – 1 intestinal nematode eggs per litre are given by World Health Organization (WHO) [Ayres, R. M. and Mara, D. D., 1996; Blumenthal, U. J. et al., 2000b; Blumenthal, U. J. and Peasey, A., 2002]. Stricter standards concerning coliforms are specified by US-EPA ($0 - 2 \cdot 10^2$ coliforms per 100 ml), but no restrictions regarding nematodes are made here [Blumenthal, U. J. et al., 2000b].

A separate collection of brown water is possible by use of no mix toilets.

3.2.1 Chemical Composition

Table 3-6: Data on brown water compositions

Reference	Magnesium (Mg) [g/d]	Calcium (Ca) [g/d]	Potassium (K) [g/d]	Phosphorous (P) [g/d]	Total nitrogen (TN) [g/d]
[1]			1.1 (0.8 - 1.4)	0.4 (0.3 - 0.5)	1.0 (0.8 - 1.4)
[2]	0.12	0.67	0.44	0.31 - 0.77	1.8 (0.9 - 2.8)
[3]			< 0.39		

[1] [Jönsson, H. and Vinneras, B., 2004], [2] [Wissenschaftliche Tabellen Geigy, 1977], [3] [Kumar, D., et al., 1991]

Nitrogen content of faeces consists of mucus, cells of the intestinal wall, digestion liquids, bacteria (approximately 17%) and food.

The inorganic faecal compounds sodium, chloride, bicarbonate, and iodine are mainly of endogenous origin. Hence concentrations of these matters are only slightly affected by alimentation. Whereas the main source of calcium, magnesium, and trace elements is food. [Wissenschaftliche Tabellen Geigy, 1977]

This listing is only a short extract of the constituents of faeces. A very detailed description can be found in [Wissenschaftliche Tabellen Geigy, 1977].

3.2.2 Dyes of Faeces

The meconium (first defecation of a neonate) is of green brown to black colour. The faeces tint of sucklings are gold yellow (bilirubin), green (biliverdin) in cases of alimentation with breast milk and brown (stercobilin) if alimanted by cow milk.

Excrements of adults are brown. This is caused by stercobilin, bilifuscin, and mesobilifuscin. Over storage time faeces darken by oxidation. The colour is darker at carnal and brighter at vegetarian alimentation. In cases of adipose dejection colour can be bright grey, because of degradation products of bile pigments. [Wissenschaftliche Tabellen Geigy, 1977]

3.3 Black Water

Black water is the technical term for toilet waste water.

Depending on the technique and cultural background it contains faeces as well as flushing water and toilet paper. The composition of black water differs from person to person. Important causes for differences are the culture (alimention, kind of anal cleansing), type of building (office and commercial buildings ? used over the day ? higher urine content, flats ? used day and night ? comparably higher brown water content), type of toilet / urinal (flushing with water stop, urinals without flushing) and personal constitution (diarrhoea). Hence, no exact data can be given here. For estimations regarding black water formation data concerning yellow and brown water can be used (see chapters 3.1 and 3.2).

In general, black water contains high loads of germs (mainly because of faecal matters), nutrients and carbonaceous compounds (as result of uptake by alimention).

Typical values for flushing water amounts in Germany are 25 - 35 litre per person and day [fbr H 201 - Grauwasser-Recycling, 2005].

3.4 Problematic Substances in Black Water Respectively its Source Separated Flows

Because of the high relevance and the topicality of organic micro pollutants these substances are discussed in a separate chapter. Further substances are listed in the collective chapter 3.4.2.

Contaminations by bacteria and viruses are discussed in the chapters 3.1, 3.2, and 3.3.

Sources for problematic substances are pharmaceutical compounds, food, drinking water, and additionally materials introduced by pipes, tanks or treatment systems.

Further common additions are detergents (cleaning of toilets or urinals), compounds disposed by inappropriate use, and in small amounts also grey water (disposal of waste water from cleaning activities).

3.4.1 Organic Micro Pollutants

One important category of organic micro pollutants is the group of pharmaceutical residues. A huge number of pharmaceutical substances (in 2004 approximately 3000 pharmaceutical ingredients in the EU [Ternes, T. A. et al., 2004]) is in use today. Intake of these substances happens directly as medication or indirectly by e.g. alimention. The main part of these compounds is excreted by urine or faeces and therefore included in black water [Organic Pollutants in the Water Cycle - Properties, Occurrence Analysis and Environment, 2006; Scheytt, T. et al., 2000; Ternes, T. A., 2000]. Some antibiotics are excreted up to 90% in unaltered form [Alexy, R. and Kümmerer, K., 2005].

A further possibility for contamination of black water with pharmaceutical compounds is the inappropriate disposal of drugs via toilets. Although in some references this is expected to be of minor relevance compared to the loads from black water [Organic Pollutants in the Water Cycle - Properties, Occurrence Analysis and Environment, 2006], a representative survey in Germany found that 15.7% of the people disposed their pills and 43.4 % their liquid pharmaceuticals via waste water [Keil, F., 2006].

The relevance of these pollutants is confirmed by another survey from Germany which discovered that barbiturates can be found in ground and surface water even 3 decades subsequent to their use, because they are nearly not biodegradable [Barbiturate nach Jahrzehnten in Gewässern nachweisbar, 2006].

Another relevant group (partly used as pharmaceuticals as well) are substances with endocrine activities. Endocrine active compounds are natural or synthetic hormones or chemicals with an effect on the hormonal system. One important source for micro pollutants in black water is the birth control pill. Some endocrine substances have been measured in effluents of waste water treatment plants (wwtp). Here, concentrations could be detected which are even above the effect level [Hegemann, W. and Busch, K., 2000].

Directly relevant for waste water purification is the biodegradability of organic micro pollutants. A lot of these compounds are persistent [Abbauverhalten von Einzelstoffen in Kläranlagen, 2004; Alexy, R. and Kümmerer, K., 2005; Kümmerer, K., 2006; Scheytt, T. et al., 2000; Schrader, C. et al., 2006; von Wolffersdorf, S., 2004]. Surveys in Germany [Friedrich, H. et al., 2005; Ternes, T. A., 2000] found the following rates of degradation for pharmaceuticals in wwtp:

- Clofibric acid ($51 \pm 10\%$ reduction in wwtp)
- Carbamazepine (0%)
- Phenazon ($33 \pm 15\%$)
- Metoprolol ($67 \pm 11\%$)
- Naproxen ($66 \pm 7\%$)
- Diclofenac ($69 \pm 4\%$)

Main part of estrogenic substances is degraded in biological treatment steps. Compared to conventional wwtp membrane bioreactors reach higher removal rates, up to 97%. The removal in wwtp with nitrification is higher compared to those without. Reason for this seems to be that the degradation efficiency of these substances depends on the sludge age. [Coors, A., 2004]

Another aspect which occurs during degradation of micro pollutants is the generation of metabolites. Metabolites as well as their effects on the environment and human beings are often not known or knowledge is at least incomplete.

Furthermore, knowledge concerning e.g. chronic effects and mixtures of organic micro pollutants is incomplete [Alexy, R. and Kümmerer, K., 2005; Coors, A., 2004].

New methods of medical treatment (drug targeting) can minimize the necessary amount of medicaments [Kümmerer, K., 2000] and as consequence even possible contaminations of black water. Possible options for a more selective treatment for waste water and its contained micro pollutants are given by innovative sanitation concepts (see chapter 3.9.2). A separate collection and treatment of faeces and urine allows other treatment techniques because of much lower volumes. Application of ozone shows good effects on elimination of micro pollutants [Andreozzi, R. et al., 2003; Andreozzi, R. et al., 2005; Larsen, T. A. and Lienert, J., 2004]. A degradation of pharmaceutical residues by ozonation of urine succeeded with an amount of about 1.6 g ozone per litre urine [Tettenborn, F. et al., 2007b]. For x-ray contrast agents a treatment by ozone is not sufficient [Thaler, S., 2007]. No increase of toxicity of waste water could be observed by Bahr [Bahr, C. et al., 2007] during tests with ozone treatment. Use of UV irradiation has an effect on micro pollutants, but the necessary dose is high [Duguet, J.-P. et al., 2004]. For micro- and ultrafiltration an effect by simply the filtration is not to be expected, because the molecules are at least 100 times smaller than the pore size of the membranes [Organic Pollutants in the Water Cycle - Properties, Occurrence Analysis and Environment, 2006]. But the use of membrane bioreactors (mbr) increases removal of estrogenic compounds [Coors, A., 2004] and other micro pollutants. Main reason for increased reduction in membrane bioreactors is the high solid retention time (srt) [Organic Pollutants in the Water Cycle - Properties, Occurrence Analysis and Environment, 2006; Back, E. et al., 2005; Clara, M. et al., 2005]. A reduction by flow through nanofiltration membranes was shown during several investigations [Kosyna, L., 2007; Pronk, W. et al.,

2006c]. Also experiments with electro dialysis succeeded in removal of pharmaceuticals [Pronk, W. et al., 2006b].

During experiments on struvite precipitation 97% of the pharmaceuticals and 98% of the endocrine substances were kept in the liquid phase [Escher, B. I. et al., 2006]. Hence, just minor pollutions of these compounds are to be expected for nutrient removal by this technique.

Experiments indicate that an uptake of drugs by plants occurs [Schneider, R. J., 2005a]. Current status of research in this field does not allow a definitive statement concerning risks for agricultural application (see chapter 3.9.2) of black water or its partial flows (yellow and brown water) as well as for sludge from wwtp. Further research is necessary [Kleine Anfrage zur Wasserrahmenrichtlinie und zu Arzneimittelwirkstoffen, 2007] and in progress [Hammer, M., 2005].

Improvements in medical practice in combination with selective treatment in source separated sanitation systems are a promising way to solve this imponderableness [Thaler, S., 2007].

3.4.2 Further Pollutants

In general black water contains germs. For secure use of black water respectively its separated streams (brown and yellow water) guidelines for accurate treatment already exist to get a hygienically safe product. [Jönsson, H., et al., 2004; Schönning, C. and Stenström, T. A., 2004]

Furthermore, for special kinds of reuse (e.g. the black water loop) colour must be removed.

Techniques for a decolourisation have been investigated during this research work and will be described later (see chapters 6.3 and 7.6).

Moreover, low loads of heavy metals are contained in urine and faeces.

Table 3-7: Metals in urine and faeces, according to [Wissenschaftliche Tabellen Geigy, 1977]

Metal	Urine [µg/d]	Faeces [µg/d]
Cadmium	2.1 (0.24 - 8.4)	160
Chromium	8.4	60
Copper	36 (10 - 114)	1,960
Gold	0.011 (0.00001 - 0.083)	
Iron	88 (0 - 120)	5,700 - 6,700
Lead	35	320
Manganese	16.4 - 23.9	3,690
Mercury	1.0 (0.16 - 2.4)	
Nickel	2.6 (0.5 - 6.4)	260 (80 - 540)
Silver	0.55 (0.18 - 1.1)	
Tin		4,000 (1,000 - 40,000)
Titanium		290
Zinc	353 (141 - 779)	5,100 - 10,300

Additional loads of metals can be caused by metallic pipes.

A contamination of black water may also appear as consequence of an inappropriate disposal of liquid waste (e.g. toxic compounds). Additionally, a low inflow of detergents can bring further chemicals (depending on the kind of detergent) into the black water stream.

3.5 Grey Water

Grey water is an expression for the domestic waste water stream without the black water stream. It is the biggest stream in domestic waste water, but the amount can vary significantly between 20 – 30 litres per person and per day in poor areas and up to several hundreds of litres per person and day in richer areas. In modern houses or houses with a renovated sanitary system in Europe grey water productions of less than 100 l/(person · day) are common [Ridderstolpe, P., 2004]. For Germany values of about 60 - 90 l/(person · day) (typical distribution 28 - 55 l/(person · day) for showers, bathing, and hand washbasin, 12 l/(person · day) in the kitchen, 13 – 40 l/(person · day) washing machine, and 3-10 l/(person · day) for cleaning) is given in literature [Li, Z., 2004; fbr H 201 - Grauwasser-Recycling, 2005].

Grey water normally contains comparably lower concentrations of pathogens, nutrients, metals and other toxic pollutants and high concentrations of easily degradable organic material (e.g. fat, oil, and other organic compounds from cooking). But the composition depends on different aspects like the lifestyle and behaviour of the residents (amount of cleaning agents, use of environmental-friendly household chemicals, pouring of hazardous substances into the washbasin).

Low contaminated grey water is easily to clean. Today purification of grey water for service water purposes is an option demonstrated in several projects [Grauwasser-Recycling-Anlage zur Produktion von qualitativ hochwertigem Betriebswasser, 2007; Chang, Y. et al., 2007; Li, Z., 2004; Mels, A. et al., 2007]. Investigations regarding purification of grey water up to drinking water quality also already have been carried out [Li, Z., 2004].

Typical compositions of grey water and values for microbiological pollution are listed in the tables 3-8 and 3-9.

Table 3-8: Typical composition of grey water in Germany, according to [fbr H 201 - Grauwasser-Recycling, 2005]

	Bathing water, showers, and hand washbasin	Bathing water, showers, hand washbasin, and washing machine	Bathing water, showers, hand washbasin, washing machine, and kitchen
COD [mg/l]	150 - 400 (average 225)	250 - 430	400 - 700 (average 535)
BOD ₅ [mg/l]	85 - 200 (average 111)	125 - 250	250 - 550 (average 360)
P _{total} [mg/l]	0.5 - 4 (average 1.5)		3 - 8 (average 5.4)
N _{total} [mg/l]	4 - 16 (average 10)		10 - 17 (average 13)
pH [-]	7.5 - 8.2		6.9 - 8.0

Table 3-9: Microbiological contamination of grey water, according to [fbr H 201 - Grauwasser-Recycling, 2005]

	Bathing water, showers, and hand washbasin	Bathing water, showers, hand washbasin, and washing machine (including baby nappies)	Bathing water, showers, hand washbasin, washing machine, and kitchen
Total coliforms [1/100ml]	10 ³ - 10 ⁷ (median 10 ⁷)	10 ⁴ - 10 ⁸	10 ⁴ - 10 ⁸
Escherichia coli [1/100ml]	10 ³ - 10 ⁷ (median 10 ⁶)	10 ³ - 10 ⁷	10 ⁴ - 10 ⁸

3.6 Green Water – Residues of Cooking

Green water is an expression used for a waste water stream containing flush water and hacked residues of cooking. Residues are reduced to small pieces by a kitchen grinder. This stream does not always exist, but in some countries it is common or like in some cities of USA use of kitchen grinders is mandatory. [Wendler, D. et al., 2004; Wendler, D., 2005]

It may be possible to substitute this stream by a solid collection of biodegradable waste. If this substitution is not wanted, solid separation and the biological treatment and treatment facilities for separated solids must be adapted respective added in grey water treatment systems to comply with this additional inflow.

3.7 White Water

White water is the technical term mainly for rain water, but also for the run-off from fog, melting snow, and hail. The amount of white water varies largely, e.g. depending on climatic conditions and seasons. Also the effects of changing climates need to be respected here, but knowledge regarding this topic is rather limited so far. A research project in Germany (Klimaveränderung und Wasserwirtschaft (KLIWA), www.kliwa.de) deals with these complex topic and its effects on water management. Kind and level of contamination depends on the air pollution, depositions on run-off areas and material of used pipes.

Options for rain water utilization are an infiltration (recharge of ground water – protection of ground water has to be ensured [Dezentrale naturnahe Regenwasserbewirtschaftung, 2006]) or a treatment and dedicated use (irrigation, cleaning, washing machine). The use of rainwater for the washing machine can save water and detergents, because rain water is very soft.

A disadvantage of the rain water use is the inconstant occurrence. Water for irrigation is of course especially needed in times without rain. Therefore, huge tanks are necessary, if this water source should be available throughout the whole year.

The inconsistent appearance is even a problem for central waste water systems as the huge additional volumes of rain water can lead to highly relevant variations in waste water flow, if white water is collected in combined sewers for rain and waste water. This increases costs for sewers as well as for treatment facilities. Hence, decentral treatment and/or infiltration systems become more and more common. Decentral white water treatment and infiltration today is seen as state-of-the-art technology [Zweynert, U. et al., 2007].

If a construction of a rain water treatment and usage system is profitable, depends on the kind of reuse as well as on several environmental and economical circumstances [Dezentrale naturnahe Regenwasserbewirtschaftung, 2006; Bullermann, M., et al., 2001; Hillenbrand, T. and Böhm, E., 2004].

In combination with black and grey water loops a ground water recharge or an application for irrigation are possible options.

3.8 Optical Perception of Colours

A very important treatment step of the black water loop is decolourisation. Hence, perception of colours and its measurement are necessary basics for evaluation of experimental success. The optical perception is a very complex process. This chapter gives basic information concerning colour and

vision, photometric measurement and its evaluation, and exemplary graphs of spectra of different coloured liquids.

3.8.1 General Aspects

The human eye is able to detect wavelengths between approximately 400 and 750 nm [Schmidt, R. F. and Thews, G., 2005]. Our eyes could even be able to see light of the ultraviolet range, but the ocular lens absorbs this wavelength. People whose lenses are removed, for example because of a cataract, can see light down till 300 nm [Falk, D. S., et al., 1990].

Light of a certain wavelength, so called monochrome light, is seen as a defined colour. In figure 3-1 colours and their approximate wavelength range are displayed.

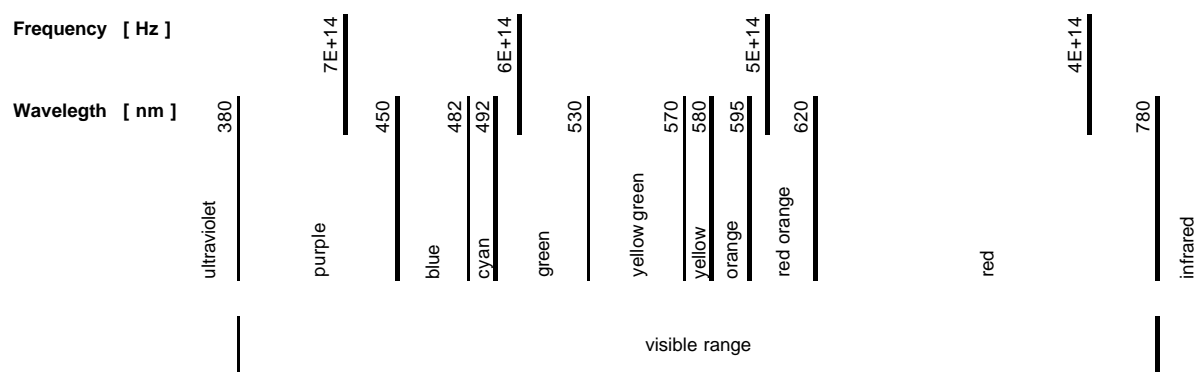

Figure 3-1: Colours and their wavelength range, values according to [Welsch, N. and Liebmann, C. C., 2003]

Perception of a colour is not a completely scientific comprehensible process, because also psychological aspects can influence vision.

In the technical field a colour is described as a colour perception. These perceptions depend on the ambient conditions and the so called colour valence. The colour valence is defined by three independent chromaticities: Hue, saturation, and brightness. Under equal conditions the same colour valences will always lead to the same colour perceptions. [DIN 5033, Part 1, 1979; Falk, D. S., et al., 1990]

Our eyes possess two types of sensory cells. We have about 7 million cone cells and 120 million rod cells [Falk, D. S., et al., 1990]. Cones are necessary for vision with high light intensity. They absorb much more light to fulfil their function than rods do. But cones allow us to distinguish between colours and provide a sharper view. Rods are needed for vision with lower light intensity. Just with rods a differentiation between colours is not possible. While a human eye adapts on the darkness the amount of our vision by rods is increasing. We are able to see faint or far away located lights. After a longer time in darkness human eyes are able to realize a candle in a distance up to 15 km. [Falk, D. S., et al., 1990]

3.8.2 Measurement of Colours

As described above the colour of the treated liquids is important for the success of the system. But a direct measurement of a colour is not possible. Only different wavelengths can be detected and as result of this also the exact colour can be estimated by a calculation.

The different wavelengths are measured with a photometer. Single wavelengths or a whole spectrum can be identified. A single wavelength does not allow a predication concerning the colour. Exceptions for this rule are monochrome light or defined spectra with just changing intensity.

The here used photometer is described in chapter 5.2.

For the estimation of defined colours several systems are available today. A validation according to the "Normfarbtafel" (standardised figure of colours) of German standard DIN 5033 part 3 is difficult, because geometrical distances do not match to felt differences between the colours. Thus, the L*a*b* colour space CIE 1976 (also called CIELAB) is a recommended colour room which allows a better comparison of measurement results and impression.

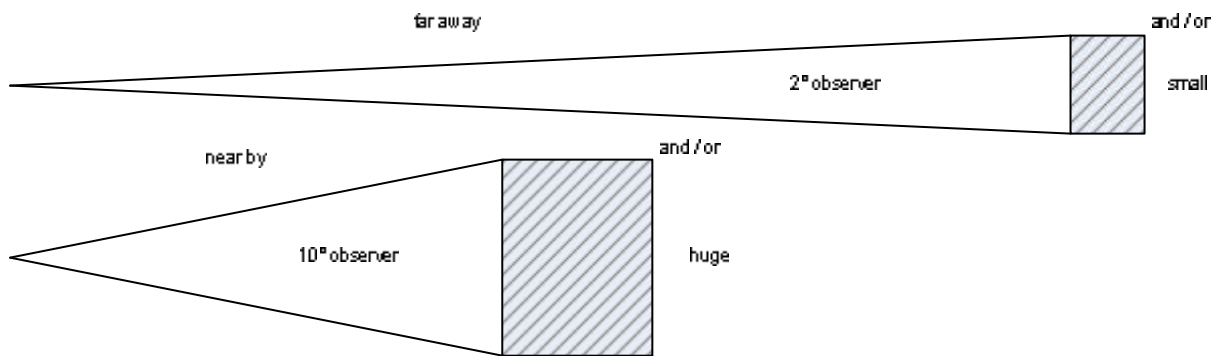

Figure 3-2: 2° and 10° observer

A colour in CIELAB-system is defined by L* (brightness) and the coordinates a* and b*, respective L*, C*_{ab} (colourfulness), and h_{ab} (hue angel). The necessary empiric formulas calculating these values are listed below. For the calculation a differentiation between a 2° and a 10° observer is necessary (see figure 3-2). For this case (samples are near to the eyes) the 10° observer is suggested (index 10). 2° observer can be used for example for the view on the sun or moon (far away objects).

$$L^* = 116 \cdot \sqrt[3]{(Y_{10}/Y_{n,10})} - 16 \quad (\text{brightness}) \quad [\text{DIN 5033, Part 3, 1992}]$$

$$a^* = 500 \cdot \left[\sqrt[3]{X_{10}/X_{n,10}} - \sqrt[3]{Y_{10}/Y_{n,10}} \right] \quad (\text{coordinate 1}) \quad [\text{DIN 5033, Part 3, 1992}]$$

$$b^* = 200 \cdot \left[\sqrt[3]{Y_{10}/Y_{n,10}} - \sqrt[3]{Z_{10}/Z_{n,10}} \right] \quad (\text{coordinate 2}) \quad [\text{DIN 5033, Part 3, 1992}]$$

$$C_{ab}^* = \sqrt{a^{*2} + b^{*2}} \quad (\text{colourfulness}) \quad [\text{DIN 5033, Part 3, 1992}]$$

$$h_{ab} = \arctan(b^*/a^*) \quad (\text{hue angel}) \quad [\text{DIN 5033, Part 3, 1992}]$$

X_{n,10}, Y_{n,10}, and Z_{n,10} are given in table 3 of [DIN 5033, Part 7, 1983].

$$X_{10} = k \cdot \sum j_1 \cdot \bar{x}_{10}(I) \cdot \Delta I \quad (\text{colour value 1}) \quad [\text{DIN 5033, Part 3, 1992}]$$

$$Y_{10} = k \cdot \sum j_1 \cdot \bar{y}_{10}(I) \cdot \Delta I \quad (\text{colour value 2}) \quad [\text{DIN 5033, Part 3, 1992}]$$

$$Z_{10} = k \cdot \sum j_I \cdot \bar{z}_{10}(I) \cdot \Delta I \quad (\text{colour value } 3) \quad [\text{DIN 5033, Part 3, 1992}]$$

$$k = \frac{100}{\int S_I \cdot \bar{y}(I) \Delta I} \quad (\text{factor}) \quad [\text{DIN 5033, Part 3, 1992}]$$

$\bar{x}_{10}(I)$, $\bar{y}_{10}(I)$, and $\bar{z}_{10}(I)$ are given in table 2 of [DIN 5033, Part 2, 1992].

ΔI is the interval between the measured wavelengths.

S_I (function of radiation of used light) is given in table 1 respective table 2 of [DIN 5033, Part 7, 1983].

$$j_I = S_I \cdot T(I) \quad (\text{colour stimulus function}) \quad [\text{DIN 5033, Part 1, 1979}]$$

$T(I)$ is the spectral transmission factor. $T(I)$ is equal to the resulting transmissivity values of the measurements with a photometer (given in %) divided by 100.

For the decolourisation the calculation of C^* (colourfulness) is a reasonable value. Hence, it will be applied for the evaluations of this thesis.

For photometric measurements with a radiation compensation S_I and $X_{n,10}$, $Y_{n,10}$, and $Z_{n,10}$ can be set to 100.

Deviating from the guidelines in the DIN just measurements at the wavelengths of 190, 235, 254, 268, 292, 380, 408, 436, 495, 566, 589, and 621 nm were carried out for these investigations (decreased exactness).

3.8.3 Optical Perception and Measurement of Yellow Water

Colour and relevant dyes of yellow respective brown water are described in chapters 3.1.3 respectively 3.2.2. No spectral measurements of brown or black water are shown here, as these measurements are of no further relevance for experimental success.

Spectra of decolorized liquid of black water loop, fresh urine, stored urine, drinking water, and some coloured liquids are shown in figures 3-3 and 3-4.

Fresh urine is a sample from one man and stored urine is from a tank of a waste water separating project in Hamburg.

Transmission of drinking water is nearly 100% over the whole visible range. The transmission of fresh yellow water has a significant (> 10%) adsorption of light below 465 nm (blue, violet). This is changed by decolourisation with ozone. Subsequent an ozone treatment only in the range below 435 nm (lower part of violet) a significant adsorption of more than 10% is measured. Main differences between these samples and drinking water can be found in for human eyes invisible UV-wavelengths. Adsorption of stored urine (brown colour) is high for all "visible" wavelengths. Only above 600 nm (orange, red) an appreciable transmission appears. Colourfulness of drinking water and decolorized liquid of the black water loop is low ($C^*_{ab} = 0,967$ respective 4,169). The C^*_{ab} value of fresh urine is significant higher ($C^*_{ab} = 23,549$) and the slightly brown, stored yellow water has the highest value ($C^*_{ab} = 35,214$).

To enable a comparison an overview over several spectra of coloured liquids is given in figure 3-4.

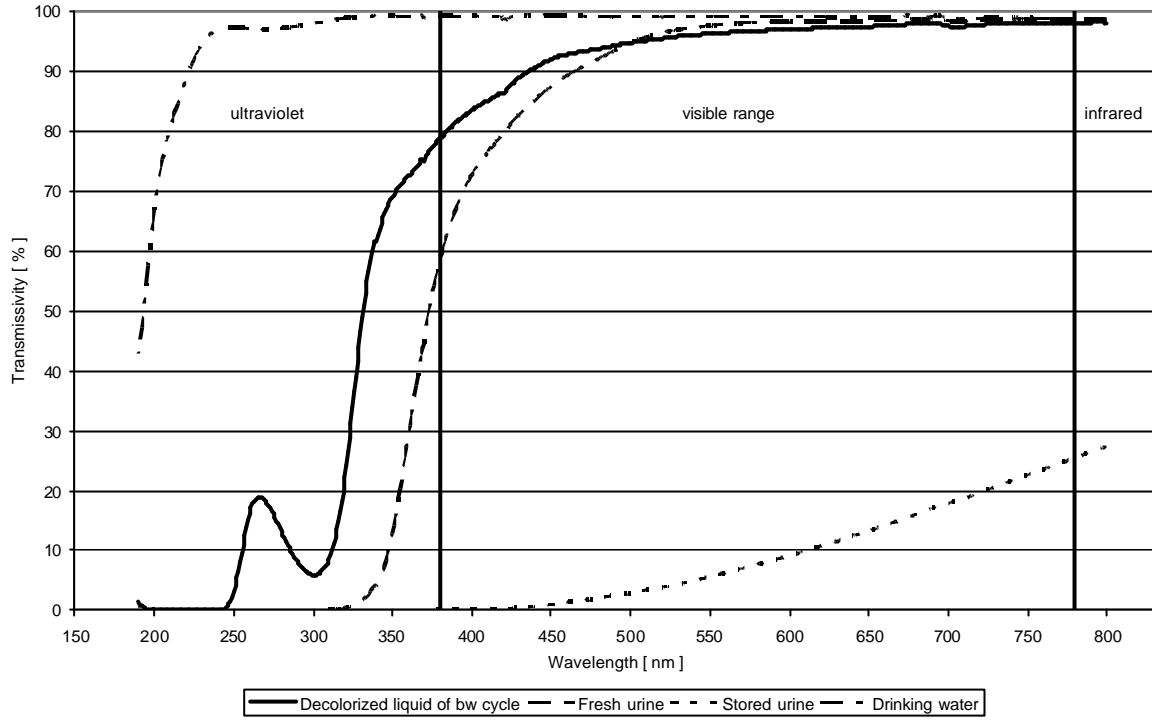

Figure 3-3: Spectra of decolorized liquid from black water loop, fresh urine, stored urine, and drinking water

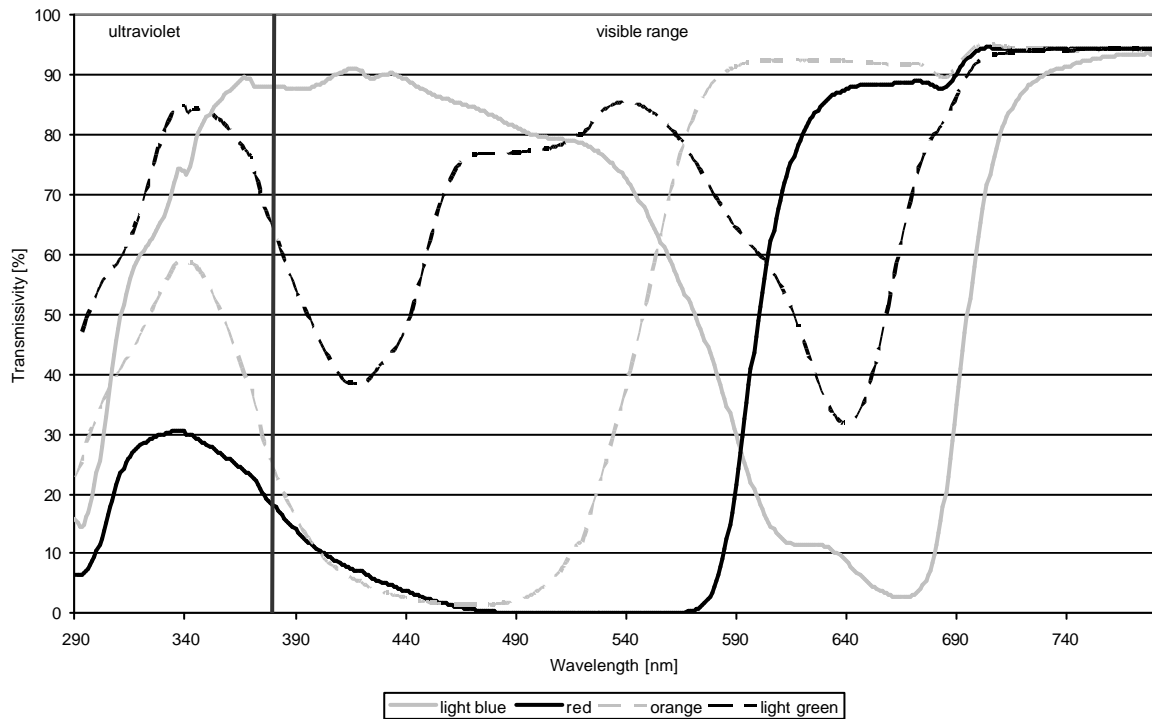

Figure 3-4: Spectra of different coloured liquids [Tettenborn, F., 2003]

3.9 Concepts for Domestic Waste Water

Waste water and sanitary concepts were subjects to considerable changes during past centuries. It is known that already 3800 B.C. storm and wash water together with faeces was discharged from households in a channel. In 5th century B.C. Romans build up the Cloaca Maxima to get rid of their waste water. In the Middle Ages knowledge concerning sewers was fallen into oblivion and faeces were disposed to the streets again. Results were outbreaks of epidemics in the cities which finally led to the construction of first modern sewers. Domestic and industrial waste water polluted the receiving waters. The implementation of water flushed toilets boosted this effect dramatically. As result treatment systems for purification at the end of the sewers (pipes) were build up around the middle of the 19th century [Hackner, T., 2004; Lange, J. and Otterpohl, R., 2000] and the today known end of pipe system was born. Up to present times this was and still is the predominant technique in all industrialized nations. Alternative solutions were only used for some single initiatives. In the last years new alternative waste water concepts were investigated and old technologies were rediscovered to solve the increasing water and waste water problems of the world. Different names (innovative sanitary concepts, Ecological Sanitation (EcoSan) or Decentralized sanitation and reuse (DeSa/R)) were used for these projects. In this work the expression, innovative sanitary systems, is used as a collective term for all these techniques and projects. These two concept groups (end of pipe and innovative sanitary systems) are described with their advantages and disadvantages in the following chapters. Finally a comparison of these approaches is made in chapter 3.9.3.

3.9.1 End-of-Pipe-Technology

The end of pipe technology is mainly a linear system [Lange, J. and Otterpohl, R., 2000]. At the end of the sewer (pipe) a waste water treatment plant should be located. Here, a mixture of rain water and domestic, commercial, and industrial waste water is purified in different treatment steps.

At a common treatment plant purified water, sludge, and in case of anaerobic sludge treatment even biogas is produced. Usage of the sludge in landscaping or agriculture can be possible. This depends among other factors like use of iron (Fe) or aluminium (Al) for precipitation on content of heavy metal or toxic components. Use of iron (Fe) respective aluminium (Al) for precipitation can influence bioavailability of phosphorous [Pinnekamp, J., 2003; Weinfurtner, K. et al., 2005; Zorn, W. and Kießling, G., 2005]. Produced biogas can be used for the production of heat and electric energy, if quality and amount of the gas render this possible.

Current research projects try to find new technologies to improve reusability of sludge and especially its nutrients [Schnug, E. et al., 2006].

Historically hygienic situation in urban areas has often been the reason for epidemic plagues. The invention of the water flushed toilet increased this problem and the pressure to find a way to remove this waste water from the cities. If no drinking water resources were contaminated by derived waste water, the construction of sewers solved this problem inside of the towns. Only heavy rainfalls, floods or earthquakes can deluge streets with hygienically dangerous water if a common gravity sewer is used.

An advantage for connected people is the convenient effect that they do not need to think about or even to handle their waste water anymore.

The use of end-of-pipe waste water systems with gravity sewers is not possible in xeric areas, because of the high water demand for transportation of solids. As a consequence of this other solutions need to be investigated and improved for at least this field of application.

Demographic and climatic changes make the planning and design of sewers and central waste water plants more and more complicated [Klimaveränderung und Siedlungswasserwirtschaft, 2007; Schmitt, T. G., 2007].

3.9.2 Innovative Sanitary Concepts

The main ideas of innovative sanitation systems are to close loops (water, nutrient or carbon loops) and to prevent the contamination of drinking water resources with pathogenic germs. The common way to reach these objectives is to keep different flows of domestic waste water separated to get the possibility to treat them according to their individual characteristics [Otterpohl, R. et al., 1999b; Otterpohl, R. et al., 1999a; Otterpohl, R. et al., 2002; Otterpohl, R. et al., 2004; Otterpohl, R., 2007a]. As consequence of these separated flows (with 2 or more pipes) most systems are running as semi central or decentral techniques [Otterpohl, R. and Oldenburg, M., 2002].

Systems with closed loops are not a new idea. Until the middle of the 19th century even in bigger cities of Europe faeces were collected (without water dilution) and used for agricultural purposes [Lange, J. and Otterpohl, R., 2000].

Innovative sanitation systems can be divided into two groups:

- Low tech solutions for areas with a low level of technical support and/or low income populations
- High tech solutions for areas with a minimum standard of technical support and possibilities for the financing of investment and depending on the system even running costs

High tech solutions can achieve the same standards and user comfort as common end-of-pipe systems of industrialized nations.

Scope of this work is a high tech system. Low tech solutions are subject of several other dissertations and publications for example at TUHH [Behrendt, J. et al., 2006; Gajurel, D. R., 2003; Gajurel, D. R. et al., 2006; Shalabi, M., 2006; Shalabi, M. et al., 2006] and therefore will not be discussed in this work.

Systems with closed water loops are for example the black water loop or the grey water loop (topic of further investigation at TUHH, purification of grey water up to drinking water quality). The reuse of water is a widely known possibility [Houtte, E. v. et al., 2004; Kroiss, H., 2004]. Simple systems with a down cycling reuse (water loop not closed) like rain water or grey water reuse for irrigation purposes are applied in a lot of modern residential premises. Basic guidelines for reuse of grey water already exist [fbr H 201 - Grauwasser-Recycling, 2005; Ridderstolpe, P., 2004].

In the long run loss of carbonaceous compounds and nutrients will have substantial impact on agriculture, if excessive exploitation takes place without sufficient refeed of these materials [Schenker, R., et al., 1997]. Organic matter improves the structure and water-holding capacity of the soil [Schönning, C. and Stenström, T. A., 2004]. Solids with high organic contents can be used as soil conditioner. A survey in Germany showed a good acceptance for compost from recycling material [Herbers, H., 1996]. Feasible technologies for this loop are for example the black water loop or rottesack systems. To enable the use of the produced solids as soil conditioner a composting or vermicomposting unit need to be erected. A combination with a fermentation unit with production of biogas would be an alternative option. Produced gas can be used to generate electric power and heat (use e.g. for sanitizing of soil conditioner).

Main aspect of the nutrient recycling is to reuse yellow water respective black water, because these streams contain the main part of the nutrients (see figure 3-5 and chapter 3.1).

Possible techniques for nutrient recycling are the black water loop or no mix toilets with storage of yellow water.

Dry fertilizer is easier to handle and to sell (smaller volume and weight, simple transport and storage). The black water loop generates solid and liquid fertilizers. The liquid fertilizer of the black water loop as well as the above mentioned yellow water of no mix toilet systems can be dried to produce a dry fertilizer.

Estimations for P loads of municipal waste water in Germany give values of 73,000 Mg P/a (domestic waste water 54,750 Mg P/a) [Pinnekamp, J., 2003]. Resulting from these values a complete reuse of phosphorous contained in municipal waste water would meet the needs of German agriculture (0.28 million Mg P₂O₅/a [Gethke, K. et al., 2005b] ⇒ 61,100 Mg P/a). A 100% reuse of phosphorous from domestic sewage still would be sufficient to cover about 90% of agricultural demand.

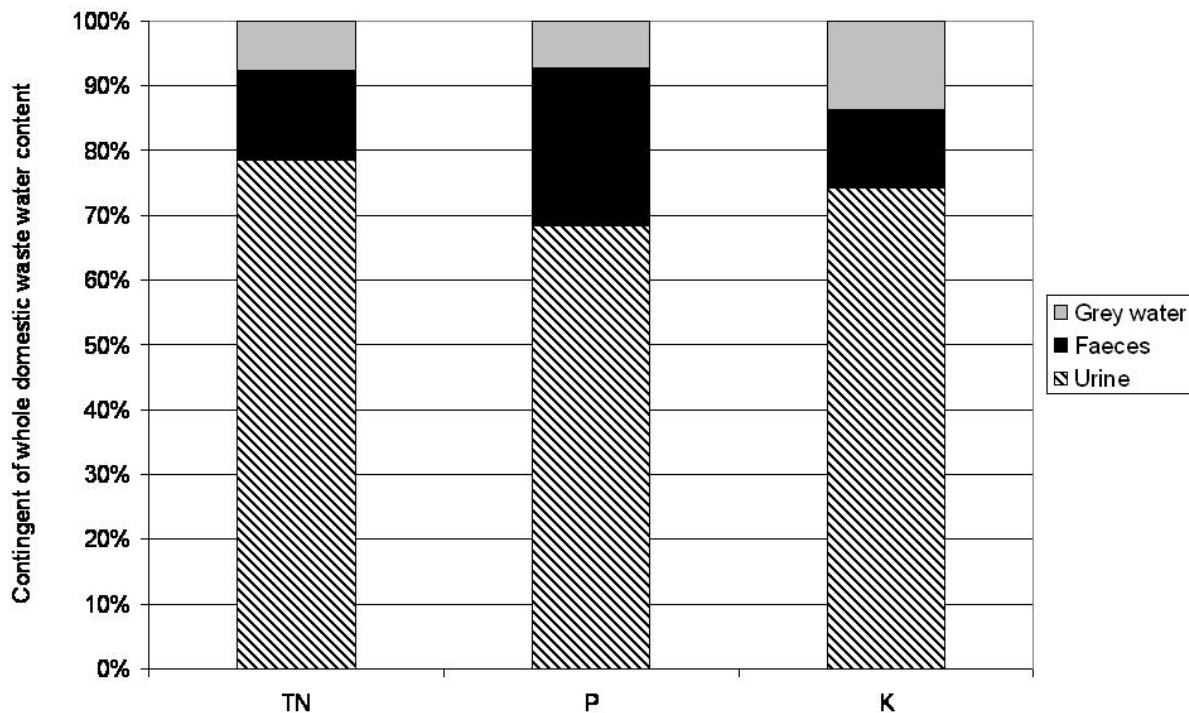

Urine and faeces: Average according to [Wissenschaftliche Tabellen Geigy, 1977]

Grey water: According to [Udert, K. M., 2002], phosphorus free detergents

Figure 3-5: Nutrient contents of domestic waste water flows

For produced fertilizer and soil conditioner observance of high standards concerning elimination of germs is an important and normally self-evident element of well designed innovative sanitation systems. Basic rules for this can be found for example in EcoSanRes Publications [Jönsson, H., et al., 2004; Schönning, C. and Stenström, T. A., 2004].

In poor countries the direct use of waste water from sewers for irrigation of agricultural land is often practiced [Jimenez, B. and Asano, T., 2004]. Often people do not have financial resources the money to buy artificial fertilizer, but they know that waste water contains the nutrients, which they need for their plants. Or sometimes they even simply have no other water source for irrigation. But waste water also contains pathogenic germs which makes this kind of irrigation extremely dangerous. Hence, there

is an urgent need to investigate and implement above mentioned technologies which can produce cheap or gratis fertilizer without these hygienic risks.

The macronutrients phosphorus (P) and sulphur (S) are limited resources on earth. Durations of 60 [Werner, C. and Bracken, P., 2004] up to 130 [Phosphat-Versorgungssicherheit und Bodenschutz bei Phosphatdüngern, 2006; EcoSanRes - Closing the loop on Phosphorus, 2005; Larsen, T. A. and Lienert, J., 2004] years for the remaining resources can be found. The big variations between these values show how difficult an estimation is (e.g. because of technical improvements and possible new mining areas).

One inhibitor for agricultural use of fertilizer and soil conditioner produced from treated waste water could become a contamination with pharmaceutical residues (see chapter 3.4). Consequences on soil, plants, animals, and consumers are sparsely investigated so far. Some of the micro pollutants seem to be persistent in the ground. Thus, without sufficient treatment agricultural use may not be safe concerning this topic. Further research is necessary on this issue. [Larsen, T. A. and Lienert, J., 2004; Schneider, R. J., 2005b] "Preliminary surveys of acceptance of a urine-based fertilizer amongst farmers and in focus groups of interested citizens have shown that in both groups the fear of micro pollutants is prominent" [Larsen, T. A. and Lienert, J., 2004]. Treatment systems with closed water loops may be a solution for this problem. In the black water loop micro pollutants pass biological treatment step and ozonation respectively UV-C treatment for several times. As a result of this by ozonation or UV-C treatment cracked micro pollutants should become biologically degradable. So even at minimum some of normally persistent compounds can be degraded in systems like this [Wasser - intelligent nutzen - nachhaltig schützen, 2006].

Compared to some mineral fertilizer produced from phosphate rock or sewage sludge an advantage for the use of an on yellow, brown, or black water based fertilizer is the low load of heavy metals [Larsen, T. A. and Lienert, J., 2004]. Additionally, fertilizer produced of phosphate rock can contain uranium in higher contents (85 – 191 mg / kg for super or triple phosphate, [Mineralische Phosphatdünger können Uran enthalten, 2005]). Investigations proved, that phosphorous of recycling systems (especially struvite) can reach the same plant availability as artificial fertilizer [Römer, W., 2006].

A high number of implemented innovative sanitation projects prove the realisability of these concepts (e.g. [Demonstrationsvorhaben "Dezentrale urbane Infrastruktur-Systeme", 2004; Bischof, F. and Meuler, S., 2004; Lange, J. and Otterpohl, R., 2000; Otterpohl, R., 2001b; Wriege-Bechtold, A. et al., 2004], project data base of gtz (<http://www2.gtz.de/ecosan/english/>)).

The step by step conversion of existing end-of-pipe concepts to innovative sanitation systems is possible [Otterpohl, R., 2000]. Even a big waste water management company in Germany, which is operating a huge sewer system and a waste water treatment plant for approximately 2 million people, undertakes first steps towards such a conversion [Rakelmann, U. V., 2002].

Also policy starts discussing on the needs to close nutrient loops [Phosphat-Versorgungssicherheit und Bodenschutz bei Phosphatdüngern, 2006].

3.9.3 Comparison of these Concept Approaches

A general comparison of the end-of-pipe systems with innovative sanitation systems is very difficult because of the high number of possible variations of these techniques. To get a brief overview of main differences these aspects are listed in the table below. Further comments and the final conclusions are given in the following text.

Table 3-10: Main points of comparison between the end-of-pipe technique and innovative sanitation systems

End of pipe systems		Innovative sanitation systems	
-	Not feasible in arid areas	+	Remarkable reduction of water demand
+	Huge operating experience, system known and accepted all over the world	-	At least partially need for further research, less experience
+	No operation works of connected people necessary	+ / -	Depending on system operation works or no operation works of connected people necessary
-	Remaining pollution of receiving water	+	Systems without pollution of water bodies possible
-	Nearly no material recycling, mixing inside sewers leads to contamination of potential resources	+	High rate of recycling of nutrients and organic compounds
-	Generation of only limited useable sewage sludge (heavy metals, acceptance)	+	Production of soil conditioner and fertilizer with very low down to no heavy metal contents
-	Long sewers ? increasing possibility of leakage, difficult to control ? high expenses for maintenance	+	Short pipes, eased maintenance
-	Heavy rain falls (monsoon), earth quakes, or floods can deluge streets with hygienically dangerous water	+	Great variety of systems offer adapted solutions fitting to different environmental and cultural circumstances
-	Gravity sewer without adequate waste water treatment (difficult to realize in developing countries) increases contamination of surface waters with germs ? important danger for drinking water supply	+	Low tech solutions are the only possibility to solve hygienic problems (sanitary and drinking water) of developing countries with water scarcity (Millennium Developments Goals)
-	Adaptation of central treatment plants and sewer systems to changing demographic and/or climatic circumstances difficult	+	Adaptation more easily possible
		+	Mineralization of persistent compounds is theoretically possible (further research needed)

Many of the advantages and disadvantages described in table 3-10 strongly depend on the chosen system, e.g. because of different rates of recycling or the fact whether soil conditioner is produced or not.

A very important point not mentioned in the table is costs. A comparison of costs is only possible for specified systems and defined local and environmental conditions.

In general, innovative sanitation systems are often a cheaper version for sparsely populated areas, because a major factor for costs of end-of-pipe technology is construction and maintenance of the huge sewer system. Just the German sewer systems 2004 had an extend of about 515.000 km (nearly 13 times around the world, more than ten times longer than the network of the German rail system) [Milliardenschwere Investitionen erforderlich, 2006; Öffentliche Abwasserkanäle umspannen 13mal die Erde, 2006; Brombach, H., 2006]. The extent of damages of the sewers in Germany is huge [Schneider, C., 2007b]. 17% of the communal sewers in Germany need to be renovated in short or medium term. Additional 14% need to be reconstructed in the long term. Costs for these works are estimated to be about 45 - 50 billion € [Tauchmann, H., et al., 2006].

A further disadvantage of sewer systems is the occurrence of infiltration water [Brombach, H., 2006]. An additional hygienic problem for gravity sewer systems is the contamination of the environment with untreated waste water as consequence of heavy rainfalls (e.g. monsoon), flooding, or earthquakes. Concerning rainfalls and floods this can be solved by the use of pressure forced sewers (pressure or vacuum systems).

Climatic changes make it more difficult to find a good adaptation for sewers transporting rain water. In Germany the research project KLIWA (Klimaveränderung und Wasserwirtschaft, www.kliwa.de) elaborates estimations for this effect.

Additionally water savings and demographic changes will become problematic for huge sewer systems [Schmitt, T. G., 2007; Tauchmann, H., et al., 2006].

End-of-pipe technology is not feasible in areas with water scarcity. Only versions with lower water demand for transportation (vacuum or pressure) are realizable [Otterpohl, R., 2007b], but these systems require high standards concerning operation and maintenance. This is a limiting aspect for application in developing countries. Hence, research in the field of innovative sanitation systems can result in technologies, which can be exported globally [Otterpohl, R., 2001a; Werner, C. et al., 2005].

The end-of-pipe technology relies on a collection and transportation of waste water by sewer or in cases of decentral treatment plants in collecting pipes. This kind of transportation of waste water causes a mixing of different water streams (brown, yellow, grey, commercial, industrial and possibly rain water). As direct result of this even potential resources (nutrients, carbonaceous compounds etc.) are contaminated with other substances included in the water streams. In most cases this is an inhibitor for a recycling of waste water contents. New technologies for an extraction of phosphorous are under investigation. Some successful experiments with municipal waste water prove that a recycling of phosphorous for agricultural or other purposes is a possible option also for end-of-pipe systems [Gethke, K. et al., 2005a; Gieske, M. et al., 2005; Schnug, E. et al., 2006]. A German estimation gives values between 33 and 67% as possible rate for phosphorous recycling in end-of-pipe systems [Gethke, K. et al., 2005b]. A direct use of sewage sludge is problematic, because of limited acceptance and contended fertilizing effect (result of precipitation with iron or aluminium) [Pinnekamp, J., 2003; Weinfurtner, K. et al., 2005; Zorn, W. and Kießling, G., 2005]. Containing contaminations and limited acceptance also led to a more stringent legislation concerning sewage sludge and hence further reduced possibilities for reuse. Innovative sanitation techniques can be a source for a fertilizer, which contains macro nutrients like nitrogen, sulphur, potassium, magnesium, and calcium and several micro nutrients, while in current end-of-pipe systems money and knowledge is necessary to destroy (remove) these resources [Dockhorn, T., 2006].

End-of-pipe systems combined with modern waste water treatment technologies can prevent high pollution loads of nutrients and easily degradable organic compounds. But even in industrialized countries with high standards concerning waste water purification the elimination of persistent

compounds at a common treatment plant is hardly possible or only for certain small fractions [Barbiturate nach Jahrzehnten in Gewässern nachweisbar, 2006; Organic Pollutants in the Water Cycle - Properties, Occurrence Analysis and Environment, 2006; Braunisch, F. et al., 2005; Heberer, T. et al., 2001; Klopp, R., 2005; Rohweder, U., 2003; Ternes, T. A., 1998]. Nowadays, as result of this some of these so called micro pollutants (see also chapter 3.4) can be found in surface (10 – 1000 ng/l [Ternes, T. A. et al., 2004; Welker, A., 2005]), ground (much lower than 1000 ng/l [Welker, A., 2005]), and drinking water [Heberer, T. et al., 2001; Rohweder, U., 1998; Rohweder, U., 2003]. In closed loop systems persistent compounds can be decomposed by oxidation processes for several times (effect of loop) [Hammer, M. et al., 2005; Tettenborn, F. et al., 2006]. This is topic of several ongoing investigations.

A lack of clean drinking water or limited access to sanitary facilities nowadays is a major problem [Prüss-Üstün, A. and Corvalán, C., 2006]. 42% of the world population (2.6 billion people) has no access to sanitary facilities. 1.1 billion people (approximately 18% of the world population) do not have access to clean drinking water. Especially in Africa, south of Sahara, 42% of the population lives without clean drinking water [Zugang zu sauberem Trinkwasser, 2005]. As a result about 6.000 children die every day [BMZ, 2004; Otterpohl, R., 2000]. 1.7 million people a year die just because of environmental related diarrhoeal diseases [Prüss-Üstün, A. and Corvalán, C., 2006]. This problem is an escalating reason for conflicts [Zugang zu sauberem Trinkwasser, 2006]. Because of economic and ecological reasons this often can not be solved by end-of-pipe systems. Innovative sanitation concepts are needed for this. For the poor regions especially cheap low tech solutions of these new concepts are the only solution.

A further hygienic disadvantage of central end-of-pipe systems with long sewers can be the use of raw waste water in agriculture of poor countries [Jimenez, B. and Asano, T., 2004]. As mentioned above innovative sanitation systems can provide the needed fertilizer without hygienic dangers and the saving of clean water may allow the substitution of waste water by uncontaminated water for irrigation. Even if the waste water is not used in agriculture, a contamination of the environment by defective sewers is possible. This is not only a problem of poor countries. Even in an industrialized country like Germany sewers are not leak proof [Kredite zur Kanalsanierung aus der Abwasserabgabe, 2004; Berger, C. and Lohaus, J., 2005; Thoma, R., 2005]. The German vice-chancellor Franz Müntefering described the current status of the sewer systems in Germany as miserable ["Kanalzustand ist erbärmlich", 2007]. The danger of this pollution possibility increases with the length of the sewers. Hence, the risk is minimal for decentral systems (EcoSan or decentral end-of-pipe systems). Additionally to the pollution the amounts of water which need to be treated at the waste water treatment plant increases by addition of infiltration water into leaky sewers. In Germany the amount of waste water is increased by 34.8% in average by this effect [Brombach, H., 2006].

An often mentioned problem of decentral systems is a lack of care and maintenance by not motivated users [Lindner, B. et al., 2004]. This difficulty can be minimized by systems with useful or money generating products. By production of purified water, fertilizer and/or soil conditioner, this can be achieved by innovative water concepts.

Implementation of innovative systems in industrialized nations is an important sign. Because people in developing countries wish to live with standards of developed countries, this can help to increase acceptance. Investigations show good results regarding the acceptance of already existing settlements with innovative concepts in Europe [Mels, A. et al., 2007]. Also the internal investigations

of this thesis regarding the acceptance of this black water loop (see chapter 7.8) delivered very good results.

Additionally the advertising effect of a more environmental friendly technique can become a further advantage for carriers of such systems.

In the long run the limitation of phosphorous and sulphur resources will be a threat even for rich, industrialized nations to apply techniques with a nutrient recycling [Phosphat-Versorgungssicherheit und Bodenschutz bei Phosphatdüngern, 2006]. If innovative sanitation concepts are the best option here or if new developments in the field of the common end-of-pipe technology will also allow this recovery by end-of-pipe systems cannot definitely be assessed today.

The above drawn comparison shows that a general decision for the optimal solution is difficult. Especially concerning economic aspects, a comparison of different options with consideration of local conditions is necessary. The demographic changes will lead to further decrease in the size of settlements in rural areas. Hence, decentral system will become more and more cost efficient here [Demographischer Wandel und Infrastrukturplanung im Bundestag, 2007].

For the next decades or centuries significant improves concerning hygienic safety, recycling rate and costs of sanitary systems are necessary. This can be done by decentral innovative sanitary sanitation systems as well as by new developments in the field of end-of-pipe technology. But as the above described comparison shows the specific treatment of source separated waste water streams nowadays shows high potential for efficient recovery systems. Especially in low tech variations of EcoSan solutions source separation is an easy and cheap way to ensure the protection of surface waters and surface near wells against pollution by pathogenic germs (needed to reach Millennium Developing Goals). [Werner, C. and Bracken, P., 2004]

4 Black Water Loop – Idea of the System and Combination with Grey Water Loop

The black water loop (patented by Ulrich Braun, Intaqua AG, [Braun, U., PCT/EP98/03316.]) is planned as one part of a system for completely waste water free houses [Otterpohl, R. et al., 2007]. The idea is to design a combination of black water loop with a high quality grey water recycling system (figure 4-1). The grey water system will produce purified water with a quality which meets the needs for drinking purposes.

Even other systems promise a waste water free premises [Bierstedt, S. and Heine, A., 2005]. But through down cycling effects of these techniques, this goal is only reachable in combination with a need for huge amounts of irrigation water.

The system combination of black and grey water loop will not result in a down cycling effect and therefore renders it possible to build up waste water free houses without any restrictions concerning external conditions and circumstances.

A main effect of waste water free houses is that there is no need for a sewer connection. Not considering other advantages - just this fact can save enormous investments especially for buildings on islands or with long distances to the next existing sewer system.

Other decentralized waste water treatment systems always have a release of purified waste water. According to the level of purification and operating safety of these systems, a more or less high pollution of receiving water bodies is an imperative result (see also chapter 3.9.1). The combination of black water and grey water loop will prevent this completely. Especially for hotels with very sensitive surroundings (coral reefs, nature reserves or other sensitive water bodies with a susceptible fauna or flora) this can ensure the economic basis (in the long run e.g. destruction or damaging of coral reefs near to a hotel by wastewater ? attraction of area decreases ? reduction of number of hotel guests ? economic danger for the hotel).

In contradiction to this the closed loop systems protect the environment against pollution and simultaneously use the waste water constituents to generate products.

Furthermore, the grey water loop can lead to an improved tap water quality (depending on current standard). The planned grey water treatment will generate high quality drinking water. In a lot of countries all over the world this means an enormous improvement compared to current tap water quality.

Further advantages of the black water loop are dramatic reduction of water demand (especially in combination with grey water loop) and production of compost and fertilizer. Because of the closed loop system all chemical compounds in the water pass the ozone / UV-C treatment and the biological treatment steps several times (cracking of persistent molecules, see chapter 3.4).

A combination of the black water loop with a composting and especially with a vermicomposting unit can improve quality and hygienically safety of produced compost. For bigger systems even the combination with a fermentation unit can be an economically and ecologically expedient way. In both cases an addition of biodegradable waste to these treatment facilities is possible.

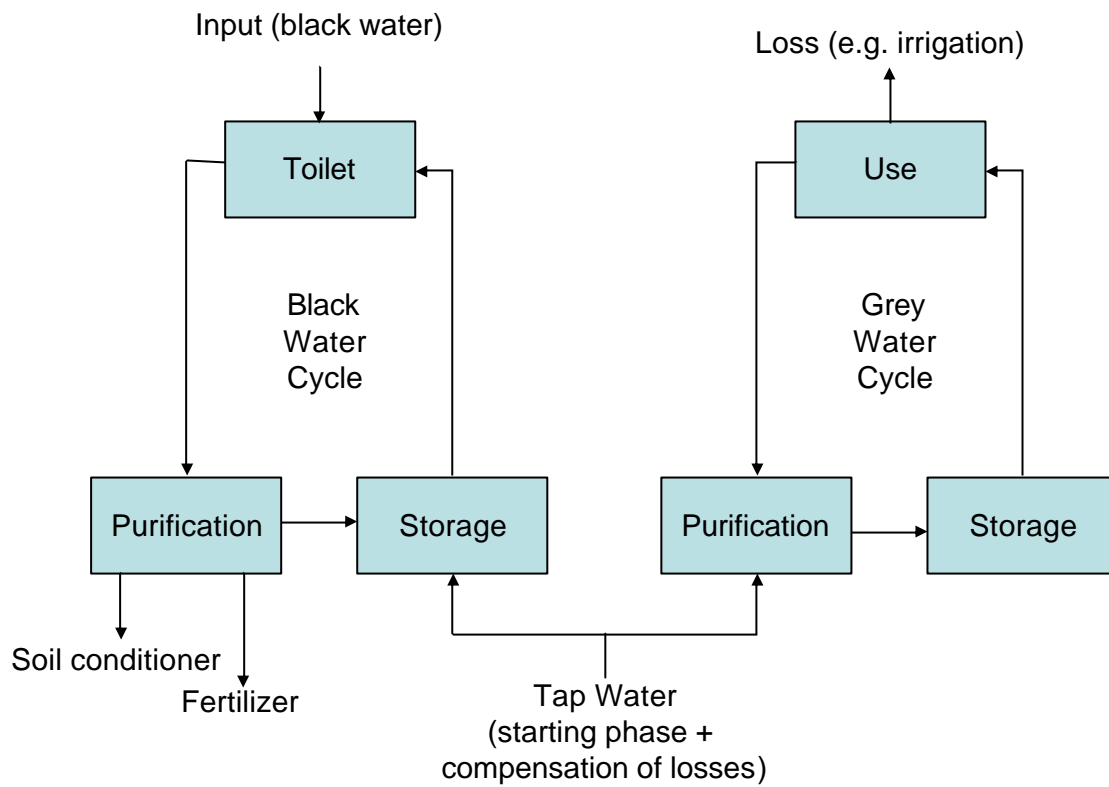

Figure 4-1: Black and grey water loop scheme

In total these advantages show the potential of the idea for an application in industrialized countries as well as in developing countries with a minimum of technical support.

5 Material and Methods of Analysis

Because of the high number of experiments and in the interest of the comprehensibility, it is necessary to link the setup descriptions directly to each test (see chapters 6 and 7). Hence, these are not displayed in this chapter.

All measurements, which could not be made directly at the setup, were accomplished in the laboratory of the AWW Institute. Therefore, the standards and always-equal operational procedures ensure a good comparability of the results.

5.1 Chemical Analysis

Methods for chemical analysis can be divided into two groups. The first group contains measurements with auto analyzers according to the current DIN (German) standards. The second group is comprised of the field of quick tests.

All chemical analyses were made just for liquids.

For TC, TOC and TIC measurements a Multi N/C 3000 auto analyzer of Analytik Jena was used. This auto analyser does not measure TOC value directly. It is calculated as the difference of measured TC and TIC.

For the TIC analysis the carbon dioxide of carbonates and hydrogen carbonates is released by addition of a 10 percent phosphoric acid. Dissolved carbon dioxide in the liquid is also quantified in this measurement. The subsequent measurement in the generated gas is done by a NDIR detector (non dispersive infrared absorption).

The TC analysis is done by pyrolysis and oxidation of the sample in an oxygen flow at high temperatures (850 °C) applying a catalyser (cerium oxide, CeO₂). The measurement of the generated gas is carried out like described above for the TIC analysis.

All further analyses were made by following quick tests of the company Dr. Lange.

Nitrogen	- Ammonia nitrogen (NH ₄ -N)	LCK 303 (2 - 47 mg/l), LCK 304 (0.015 – 2.0 mg/l)
	- Nitrite nitrogen (NO ₂ -N)	LCK 342 (0.6 – 6.0 mg/l)
	- Nitrate nitrogen (NO ₃ -N)	LCK 339 (0.23 – 13.5 mg/l), LCK 340 (5 - 35 mg/l)
Phosphorous	- Total phosphorous (P)	LCK 349 (0.05 – 1.50 mg/l), LCK 350 (2 - 20 mg/l)
	- Orthophosphate (ortho-P)	LCK 049 (5 - 90 mg/l PO ₄)
Magnesium	- Total magnesium (Mg)	LCK 326 (0.5 - 50 mg/l)

5.2 Further Measurements and Analytic Methods

Some further values were measured in the laboratory of the AWW Institute (dry residue, photometric colour measurement) or in situ at the experimental setup (pH, oxygen content, total solids inside biological treatment step, redox potential, conductivity and temperature).

Dry residue of separated solids is measured according German standards [DIN EN 12 880, 2001]. Always three samples have been taken to minimize risk of mistakes in the field of sampling or measurement.

Transmissivity respective absorption was quantified by a Jasco V-550 UV/Vis spectrophotometer. According to German standards [DIN 6164, 1980a; DIN 6164, 1980b; DIN 5033, 1979b; DIN 5033, 1979a] a calculation of a certain colour by measurement of a list of transmissions at defined wavelength has been carried out (for detailed description see chapter 3.8). To allow this proceeding the transmissions was measured at 13 respective 18 fixed wavelengths.

In situ controls of parameters were done with the following listed equipment.

pH	Pre-tests	WTW pH 196 with BlueLine [®] pH combined electrode
	Pilot plant	WTW IQ Sensor Net, SensoLyt [®] 700 IQ with SensoLyt [®] SEA pH combined electrode
Oxygen		WTW IQ Sensor Net, TriOxmatic [®] 700 IQ
Redox potential		WTW IQ Sensor Net, SensoLyt [®] 700 IQ with SensoLyt [®] PtA Redox combined electrode
Conductivity		WTW IQ Sensor Net, TetraCon [®] 700 IQ
Total suspended solid		WTW IQ Sensor Net, ViSolid 700 IQ
Temperature	Pre-tests	WTW 196 with BlueLine [®] pH combined electrode, via integrated NTC
	Pilot plant	WTW IQ Sensor Net, via integrated NTC
Volume flow	Water meter (according to German standards)	

6 Lab Scale Tests

These tests enable the selection of technologies for the pilot plant and, so far these tests were finished before construction of pilot plant began, they gave first results for dimensioning of the plant.

Additionally these lab scale tests were a possibility to investigate certain crucial aspects of the BWL in detail.

6.1 Biological Treatment

Scope of these lab tests is the investigation on the topics odour and colour of urine as well as the tendency of urine to generate foam. But to be able to succeed in these investigations in a first step a stable biological treatment with especially stable nitrification of this salty and highly by nitrogen loaded liquid need to be achieved. Additionally activated sludge should be adapted to the conditions of urine degradation and produced as seeding sludge for the pilot plant.

6.1.1 Description and Results

Two different kinds of experimental set-ups have been used. One reactor consisted of an activated sludge tank with suspended bacteria and one with a fixed bed system (see figure 6-1).

The activated sludge system consisted of only one tank (approximately 3500 ml). Aeration was done by blowing compressed air via air diffuser into the water. pH adjustment was done manually by addition of NaOH.

The fixed bed system (see figure 6-2) has been made up of two tanks (tank 1: collecting tank, tank 2: fixed bed reactor - filled with plastic carrier material, volume of approximately 3500 ml each). A pump injected the water of tank 1 into the bottom zone of tank 2. Aeration took place in tank 1. It was realized like in previous described set-up. pH adjustment was done automatically (presetting: 7.5 – 8.5) by addition of NaOH into tank 1.

In both experiments pH measurement has been performed by WTW pH 196 (see chapter 5.2). Urine was added discontinuously (normally 5 days a week).

Inoculation sludge was used for further lab tests respective the pilot plant directly after the withdrawal from the pre-test or stored in a freezer ($T < -20^{\circ}\text{C}$) when it could not applied immediately.

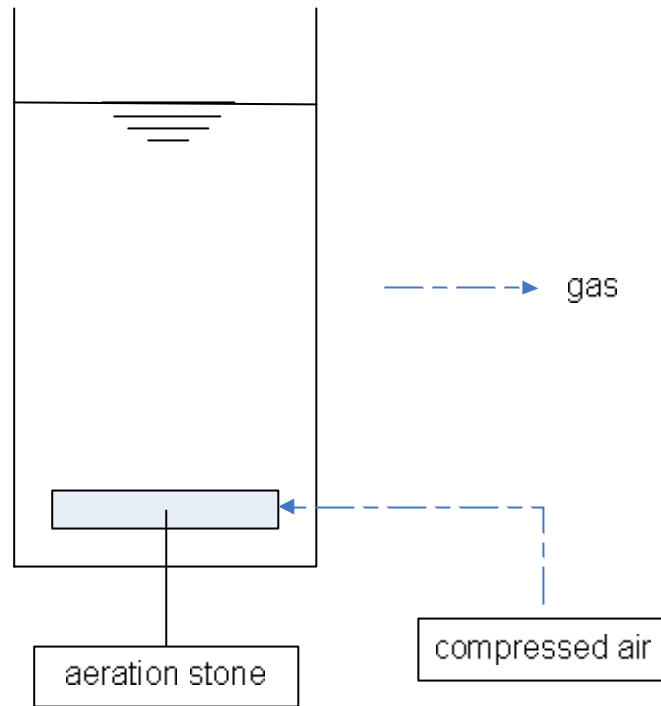

Figure 6-1: Set-up of biological treatment pre-tests – activated sludge system

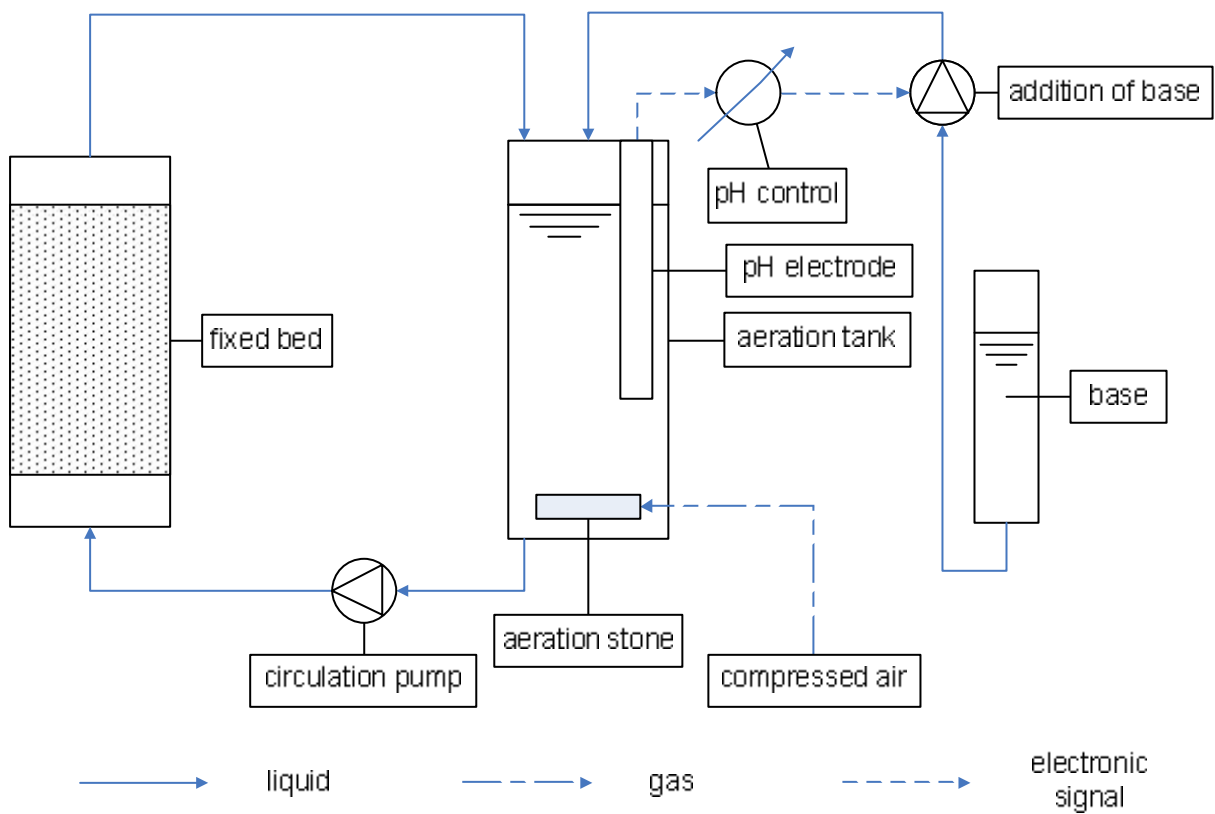

Figure 6-2: Set-up of biological treatment pre-tests – fixed bed system

6.1.2 Interpretation and Conclusions

After about half a year of adaptation the biological treatment was running stable. High nitrate concentrations were reached (up to 3.4 g NO₃-N / l) whereby nitrite concentrations remained low (in steady state less than 10 mg NO₂-N / l).

One effect of biological treatment was a change of colour. The yellow colour of the fresh urine changed to a dark brown after treatment. Additionally, odour disappeared during treatment.

During pre-tests foam problems appeared. By injection of gas in untreated urine very stable foam originated. This effect was reduced but not completely eliminated by the biological treatment.

6.2 Storage and Deposition Tests

Storage tests were supposed to show, if visible effects on biologically pre-treated yellow water appear over a longer storage time under different conditions. Especially colour and odour are of major concern here.

Deposition tests were designed to investigate intensities of possible depositions. During application of a black water loop, it might occur that single toilets are not used for even several weeks. But even after longer periods without use, the cleaning of toilets must be possible without resistant particles. Otherwise this system could show up with too high running costs for exchange of toilets.

6.2.1 Description and Results

For storage tests four samples (approximately 400 ml each) of biologically pre-treated yellow water (from experiments of chapter 6.1) have been stored under different conditions. Experimental time was 26 weeks (= ½ a year).

For test 1 two samples have been stored capped. One was stored with influence of daylight and one in darkness. Urine content was about 20%. At the beginning all samples have been clear and light yellow with some small solids in it. Nearly no smell was detected. At the end of the storage no recognizable changes in colour and odour were stated. As well as between the two storage conditions visually no difference could be observed.

Test 2 was also carried out with two samples. Caps had a hole with a diameter of approximately 1 cm. Hence, in contrast to test 1 an exchange of gas was possible. Again one sample was stored under daylight conditions and one in darkness. Content of urine was about 35%.

At beginning samples had a dark yellow colour and some small solids were visible. Samples did not show significant odour.

At the end of these storage tests no changes concerning colour or smell could be detected. At least regarding these two parameters the biological pre-treatment resulted in a stable product.

For the deposition tests fresh urine (100% urine content) or biologically pre-treated yellow water (approximately 20 – 25% of urine) was stored in a toilet. The storage time varied between two and five weeks for fresh (3 tests) and 8 weeks for biologically pre-treated yellow water (3 tests as well). All six tests were carried out with the same toilet to simulate a longer period of application. The used toilet was a simple model without special surface coating (e.g. Lotus effect). At the end of the storage time

yellow water was released and the toilet was twice softly flushed with 1000 ml water. If necessary toilet subsequent was wiped out with a wet piece of paper towel, but no detergents have been applied. This minimum level cleaning procedure was sufficient for a complete removal of all visible residues. A normal toilet cleaning was expected to be more intensive and would include application of detergents.

These tests led to no hints on possible obstacles regarding cleaning of toilets flushed by purified black water (regarding salt content similar to the here used yellow water).

6.2.2 Interpretation and Conclusions

Storage tests showed that biologically pre-treated yellow water is stable concerning its colour. Storage does not have significant influence on odour of biologically pre treated yellow water. At beginning as well as after storage almost no smell has been detected. Biological pre-treatment seems to be a sufficient solution for odour removal in this case.

Depositions mainly can be removed by soft flushing with water. Sometimes wiping with a wet paper towel is necessary. Complete removal always was possible without use of detergents. These results indicated that no relevant problems with depositions are to be expected for a toilet system flushed with purified black water. During storage depositions appeared, but results suggested that with sufficient cleaning even long term use (renovation of toilets in common intervals) should be possible for black water loop systems.

6.3 Decolourisation Tests

Decolourisation is a fundamental need for reuse of black water as flush water. Users would most likely not accept brown or yellow flush water. It is a psychological aspect, which must be accounted here. Biological treatment does not reach a decolourisation (see chapter 6.1). In contrast it resulted in a darker colour (change of colour from light yellow to dark yellow or brown).

6.3.1 Screening of Suitable Technologies

In the AWW Institute following listed technologies have been tested for decolourisation purpose:

- Activated carbon adsorption
- Ozonation
- Ultrasonification
- UV-C irradiation (including respective not including wavelength of 185 nm)
- UV-A irradiation with different combinations of pH-adjustment and addition of TiO₂ respective H₂O₂

Experiments with UV-A and TiO₂ were carried out using fresh as well as biological pre-treated urine.

Only UV radiation and ozonation have shown a decolourisation effect. Hence these tests are described more detailed in the following sections. The other experiments are not of interest for further

investigations and therefore are not described here. Material and methods of these tests are shown in earlier publications [Gulyas, H. et al., 2004; Lindner, B. et al., 2003].

In literature in contrast to these results also successful experiments with activated carbon are described [Boehler, M et al., 2007]. The amounts of the powdered activated carbon (PAC) are in the same range like in the investigations at TUHH, but the main difference is the pre treatment. While at TUHH fresh urine was treated, in the other experiments a biological pre treatment took place prior to the decolourisation by the PAC. According to [Boehler, M et al., 2007] an amount of 100 g PAC per m³ of black water (4 l of rinsing water per flush) is sufficient for biologically pre treated and membrane filtrated (pore size of 0.04 µm, ultrafiltration) black water.

6.3.2 Tests with UV Emitters not Including 185 nm

UV wavelength range is subdivided into three ranges (A, B, and C). UV-A is the wavelength range between approximately 320 and 400 nm. It is the part with the smallest energy emission of the whole UV range. The range of UV-B is between 280 and 320 nm. Highest energy outputs (UV-C) ranges between 100 and 280 nm. 254 nm is normally used for disinfection, because DNA has its maximum of adsorption (? strongest effect) at this wavelength. UV-light of 185 nm can be used for ozone production.

6.3.2.1 Description and Results

Tests with two setups and three different UV-sources have been completed. First setup [Breuer, K., 2002; Gulyas, H. et al., 2004] has been made of normal face tanners (Philips HB 171) installed 30 cm above liquid level of reaction tank (approximately 25 W UV-A/m² and 0.5 W UV-B/m²). The reaction tank (1000 ml sample volume) has been mixed by a magnetic stirrer with a velocity of 200 rpm. In the following listing all tested combinations of pH-adjustment and addition of TiO₂ and / or H₂O₂ are given:

- UV-A irradiation (at original pH, pH of 3, and pH of 11)
- UV-A in combination with TiO₂ (at original pH, pH of 3, and pH of 11, TiO₂ concentration of 4 g/l)
- UV-A in combination with H₂O₂ (at original pH, H₂O₂ concentration of 1 g/l)
- UV-A in combination with H₂O₂ and TiO₂ (at original pH, TiO₂ concentration of 4 g/l, H₂O₂ concentration of 1 g/l)

Experiments with UV-A and TiO₂ were made with fresh as well as with biological pre-treated urine. pH-adjustment was done by adding NaOH respective HCl. The period of UV -A radiation impact on the sample has been up to nearly 100 hours.

The second group of experiments has been done by two flash tube reactors. Treated water poured down tube walls while it has been irradiated by a low pressure mercury lamp (200 watt, wavelength maximum at 254 nm) respective a medium pressure mercury lamp (400 watt, wavelength range between 200 and 580 nm, 2 W UV-A/m², 3.5 W UV-B/m², and 2 W UV-C/m² at a distance of 1.0 m). Tests have been implemented with 6000 ml undiluted urine without biological pre-treatment. No chemicals have been added here (pH not adjusted). Tests have been carried out at normal room temperature of about 20°C.

6.3.2.2 Interpretation and Conclusions

All tests with irradiation of UV light not including 185 nm do not show any decolourisation effect. In some experiments changes of colour from yellow to brown appeared. Because some of these experiments resulted in a reduction of liquid volume, this can also be reason for colour change. Additionally chemical reactions can be the cause for it. This can not be concluded from the performed tests.

These treatments are no possible options for the black water loop.

6.3.3 Tests with UV Emitters Including 185 nm

Reactors of these experiments did emit UV-light of 185 nm wavelength (part of UV-C, ozone producing, see also chapter 6.3.2). Mostly common UV-lamps do not emit this wavelength, because in most cases ozone production is not wanted. To be able to avoid 185 nm radiation special quartz tubes are used which absorb this wavelength.

6.3.3.1 Description and Results

These experiments were conducted using a reactor of the company sterialAir (AQD34-C, thin-film reactor, output of 13.8 W UV-C, 18 W electric power consumption). Tests were made with fresh urine, biologically pre-treated urine, and liquid of the black water loop. No chemicals have been added. System setup (see figure 6-3) composed of an open tank (sampling and storage of liquid), a circulation pump (ProMinent, membrane pump), and the UV reactor described above.

In these experiments a volume of each between 0.6 and 2.0 litre of liquid has been treated.

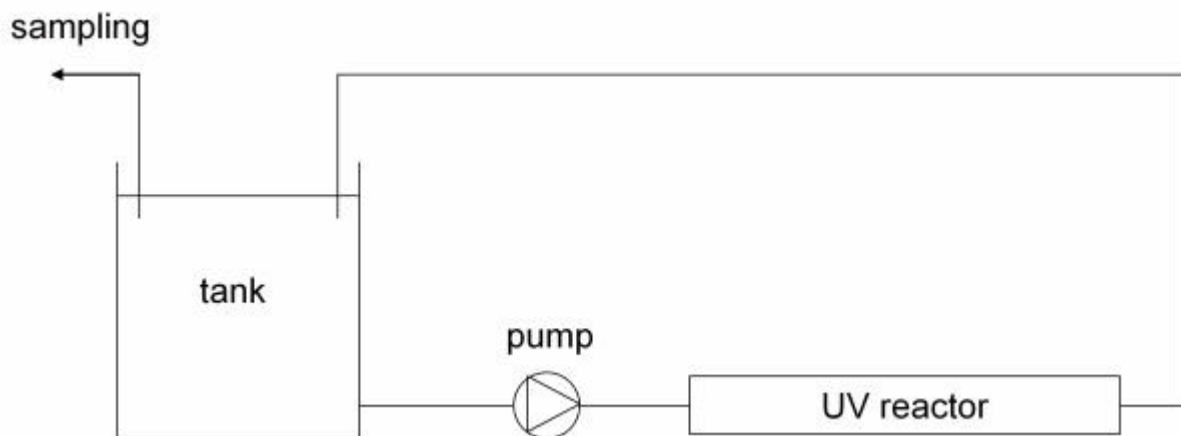

Figure 6-3: System set-up of UV-C pre-tests (including 185 nm)

For “measurement” of colour intensity the value C^* (free of unit, colourfulness according to German standard, see chapter 3.8) was used to get objective results.

During treatment of untreated urine samples C^* increases considerably before decolouration (C^* -decrease) appeared. In contrast to this in tests with pre-treated liquids just a comparably short time and extend of increase and much quicker decolourisation happened. In tests with liquid from the black

water loop no increase could be detected at beginning of decolourisation.

C* start values of biologically pre-treated samples were considerably higher than of untreated (see figure 6-6). These measured values corresponded very well with the optic impression.

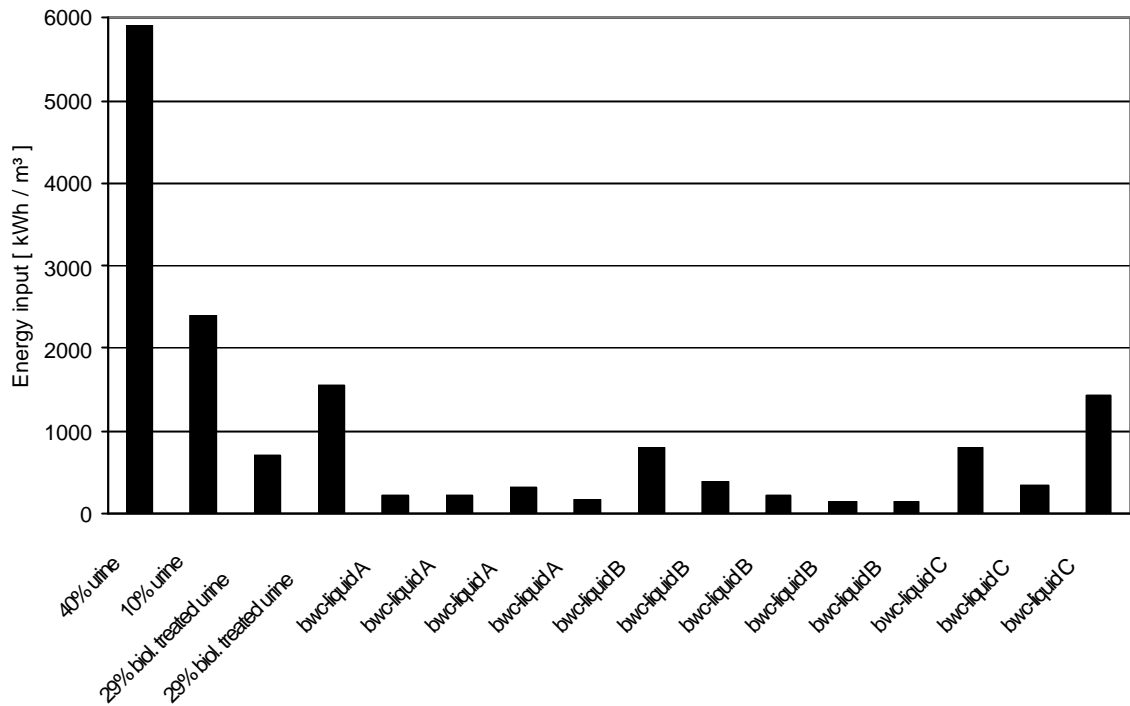

Figure 6-4: Energy demand for visibly complete decolourisation (C* values between 0.74 and 3.83)

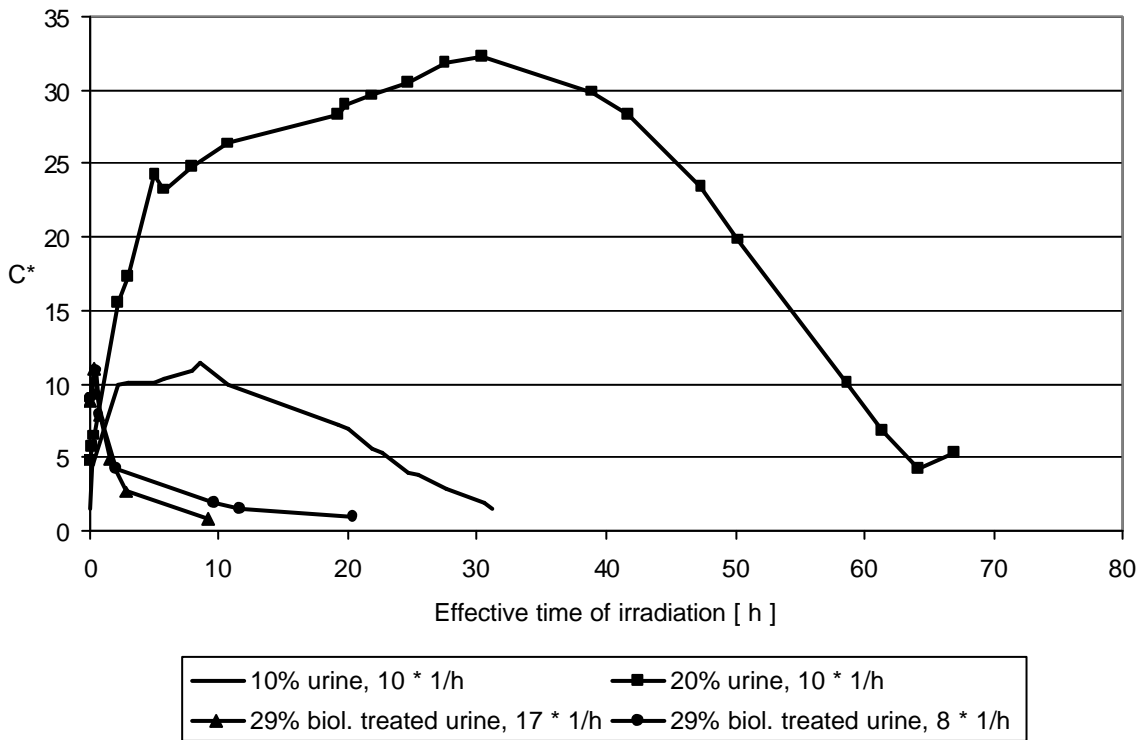

Figure 6-5: Exemplary C* values during UV treatment with given rate of recirculation of the liquid

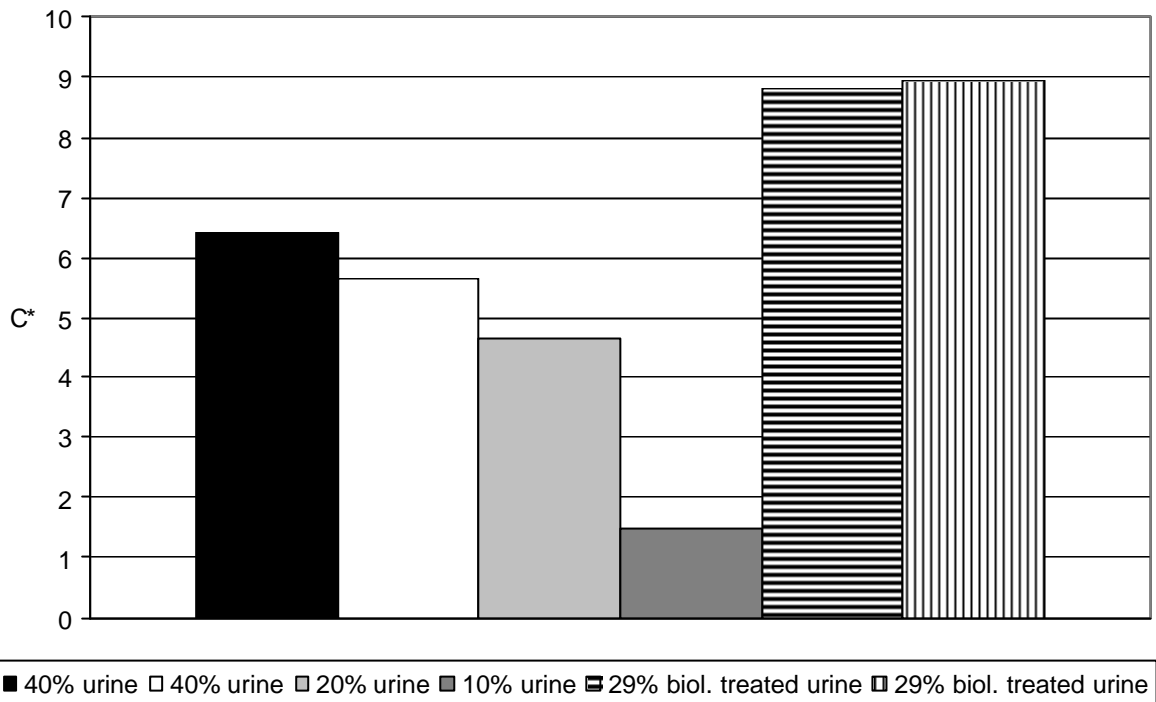

Figure 6-6: C* values of different samples at beginning of treatment

Tests with liquid of the BWL showed a remarkable effect of pump velocity respective recirculation rate (see figure 6-7). Increasing recirculation by a factor of 2 reduced necessary irradiation time to 1/3. Even tests with biologically pre-treated yellow water indicated this kind of effect. Only during experiments with more intensive pre decolourized liquid of the black water loop (by a more powerful UVC lamp) no significant effect concerning this issue could be observed anymore. Above a level of 60 l/h (pump velocity) respective 30 * 1/h (recirculation rate) no further decolouration increase could be observed.

UV treatment caused an increase of pH for fresh urine (6.5 to 8) and a decrease for biologically pre-treated (8 down to a value between 6 and 7).

Odour changed from normal urine smell (fresh urine) respective no smell (biologically pre-treated urine) to a slight amine odour.

After treatment samples were stored and monitored. All decolourized samples stayed colourless (C* values stable). pH increased slightly during tests made with fresh urine and remained constant for experiments made with biologically pre-treated urine. Odour of all samples damped down during storage.

C* values of subjective colourless samples were in the middle about 1.5 (minimum: 0.7, maximum: 3.8, see figure 6-8).

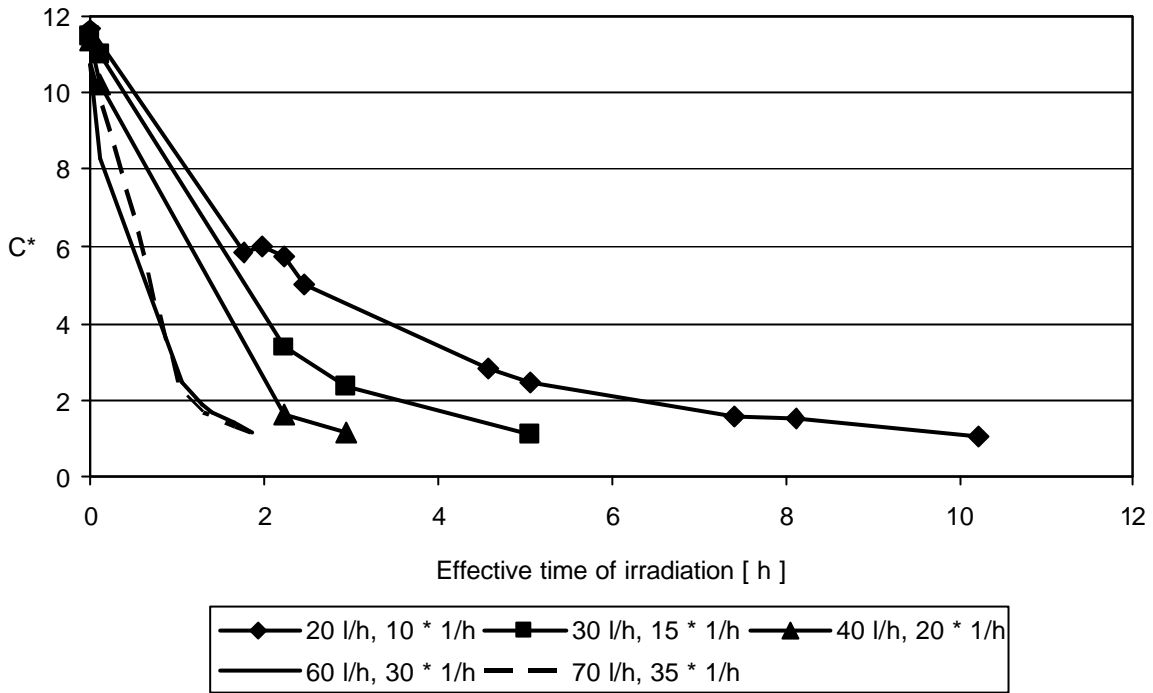

Figure 6-7: Influence of pump velocity respective recirculation rate on decolourisation

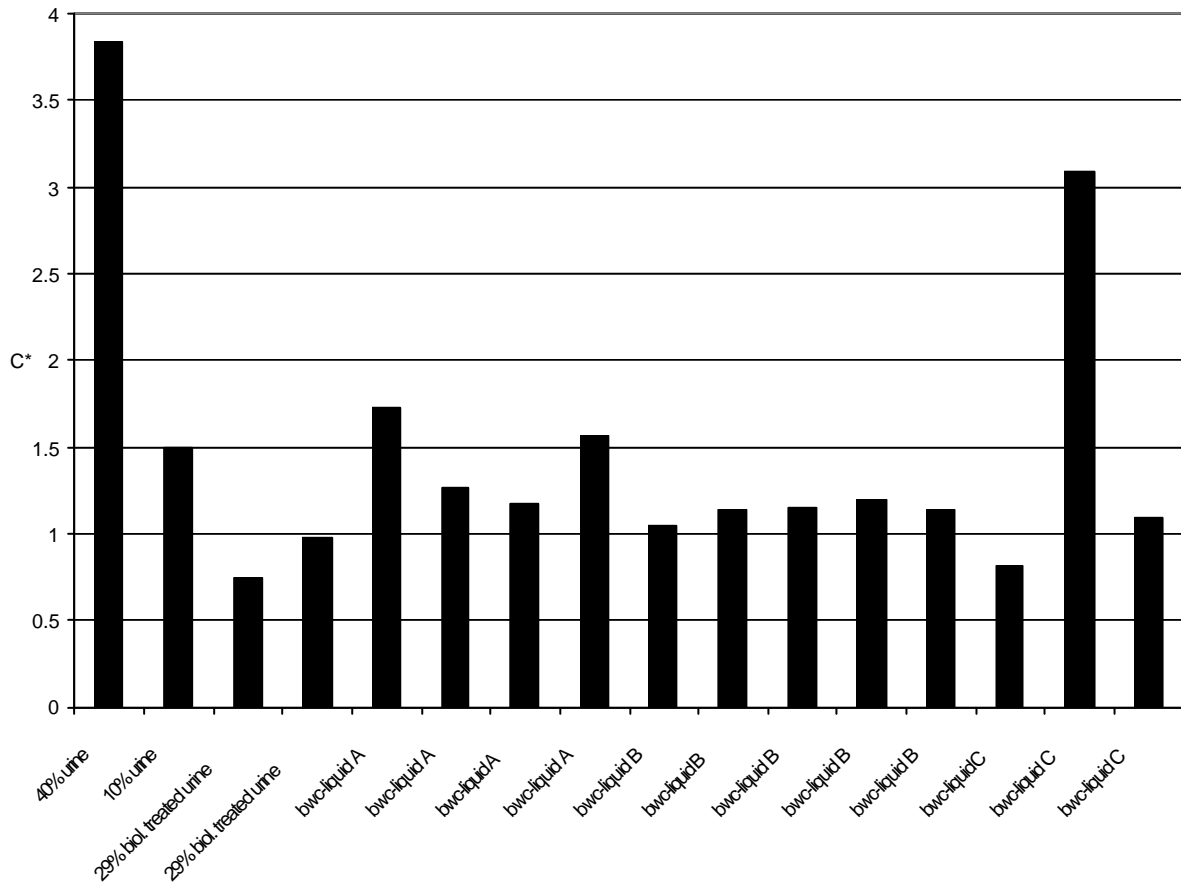

Figure 6-8: C* values corresponding with a subjective colourlessness subsequent UV treatment

Further data concerning these lab tests is listed in the appendix (chapter 14.1, figures 14-1 to 14-3).

6.3.3.2 Interpretation and Conclusions

Conducted experiments showed that application of UV-C (including 185 nm) is a possible option for decolourisation of yellow water respective liquid of the black water loop, but energy demand for this technique is very high.

Tests showed a remarkable influence of pump velocity respective recirculation rate. Just strongly pre decolourized samples of the black water loop showed no effect regarding this test parameter. An assumed reason could be the increased addition of oxygen by rising pump velocity (a membrane pump was used) and as result a production of ozone and subsequent OH radicals. But prove of this assumption could not e conducted the accomplished tests.

In general the experiments showed that biologically pre-treated liquid can be decolourized by UV-C at much lower amounts of energy than untreated.

Storage of decolourized samples showed that regardless a biologically pre-treatment no relevant recolouring appeared.

UV treatment resulted in a slight amine smell. This odour always was reduced by storage. Smell was not strong enough to be able to become relevant for reuse as flush water.

Measurement of C^* as degree of colour intensity led to a subjective limit of colourlessness of approximately 1.5. The subjective colourlessness (see chapter 3.8) is very important to reach a sufficient acceptance of the black water loop.

6.3.4 Experiments with Ozone

Lab scale tests with ozone were performed as batch (investigations concerning general possibility) and as continuous flow (investigations concerning performance in a possible real implementation) experiments.

During these tests ozone concentrations were measured by ozone analyzers from the company BMT 361 (Meßtechnik Berlin). Ozone production was done by a lab ozoniser 301.7 of the Erwin Sander Elektroapparatebau GmbH (max. 250 W). For a calculation of energy demand for ozone production with air a value of 14 kWh/kg O_3 [Bünning, G., 1995] is used. For ozone production with oxygen an energy demand of 6.5 – 9.8 kWh/kg O_3 is given in the same reference (not calculated the energy demand for the O_2 generation).

For measurement of colour intensity the value C^* (see chapter 3.8) was used to get additionally to the subjective impression also objective values for this parameter.

6.3.4.1 Batch Tests

Objective of these tests was to find out if ozone is a possible option for a decolourisation of yellow water. The very simple set-up of the experiments allowed no determination of exact rated values for ozone or energy demand.

6.3.4.1.1 Description and Results [Gulyas, H. et al., 2004]

The experimental set-up of these tests consisted of a bubble column with a diameter of 12.5 cm. Ozone concentration is measured before gas was injected into the reactor. Injection took place by a diffuser placed near the bottom of the column. At the top of the reactor the outlet for off gas was placed. Tests were conducted with untreated respectively biologically pre-treated urine.

Ozonation via bubble intrusion caused massive production of foam.

For decolouration of untreated urine 16.2 – 21.6 kg O₃/m³ respective 5.4 – 7.2 kg O₃/m³ for biologically pre-treated urine was necessary. All these samples reached a complete colourless status but without further treatment always a recolouring appeared during storage. Addition of hydrogen peroxide was found as possible option to prevent this.

After ozonation samples showed no relevant odour anymore.

6.3.4.1.2 Interpretation and Conclusions

Decolouring by ozone is a technically possible option. Injected ozone amounts of 16.2 – 21.6 kg O₃/m³ for untreated urine respective 5.4 – 7.2 kg O₃/m³ for biologically pre-treated urine correspond with an energy demand of approximately 227 - 302 kWh/m³ (untreated) respectively 76 - 101 kWh/m³ (biologically pre-treated). These values are to be seen as maximum level because used reactor was not designed for a proper usage of the injected ozone (12.5 cm diameter of reactor ? just 3.5 cm liquid height ? extremely limited mass transfer). Additionally ozone concentration in the off gas was not measured. Therefore all the injected ozone was counted as used for decolouration which again led to too high values.

In all treated samples recolouring occurred, if no hydrogen peroxide was added.

As already stated in the descriptions the ozonation resulted in a nearly odourless product.

6.3.4.2 Experiments with Continuous Flow

Objective of these tests was to find upper limits of ozone respective energy demand. Found values are applicable as upper limits, as yellow water contents were set above expected BWL additions per loop step (in every treatment loop just fresh added liquid must be decolourized). Rates of fresh liquid in BWL are expected to be lower than 20% (equivalent to 500 ml urine mixed with just 2000 ml flush water).

Second objective of these continuous flow experiments was to find and solve technical obstacles of yellow water decolourisation by ozone.

6.3.4.2.1 Description and Results

The used reactor consisted of a bubble column (diameter of 2.15 cm) with a wider head column (4.5 cm). The complete height was about 43 cm. Ozone was applied by a diffuser in the bottom of the reactor.

Experiments were made with fresh (40 and 100%) and biologically pre-treated urine (29%). For each test a volume of 600 ml was used.

Table 6-1: Ozone respective energy demand for decolourisation

Liquid	Final C*	Ozone input [kgO ₃ /m ³]	Energy input [kWh/m ³]	Status
100% untreated urine	2.2	15	210	Colourless but recolouring
	Status not reached during test			Colourless and no recolouring
40% untreated urine	1.49	2.3	32.1	Colourless but recolouring
	0.74	58.2	814.9	Colourless and no recolouring
29% biologically pre treated urine	1.55	1.5	21	Colourless but recolouring
	0.37	8.5	119	Colourless and no recolouring
29% biologically pre treated urine	0.93	1.1	15.4	Colourless but recolouring
	0.36	< 13.6	< 190.6	Colourless and no recolouring

Ozone respective energy demands needed for decolourisation are given in table 6-1. In case of the experiment with 100% untreated urine status with no recolouring was not reached until end of experiment.

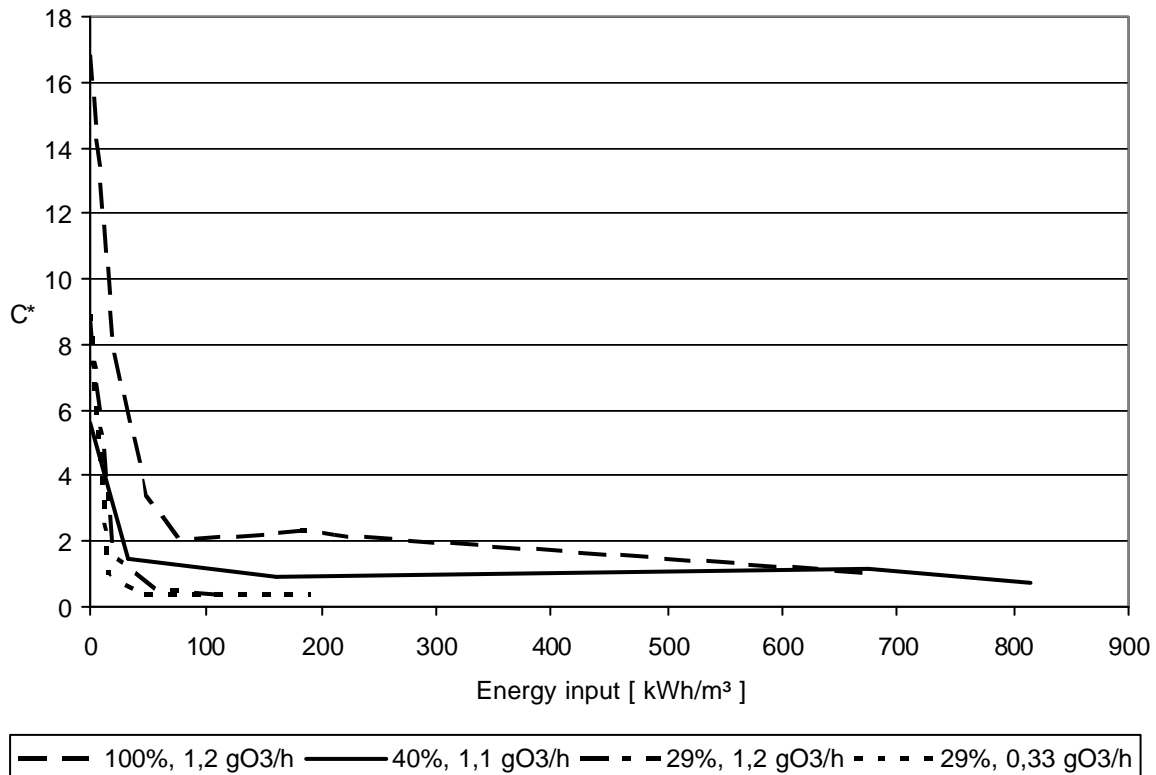

Figure 6-9: C* values compared to energy input during ozone treatment (100% and 40% samples untreated, 29% samples biologically pre-treated)

Ozone reduced colour intensity rapidly. Energy demands for colourless status differ considerably. Demand ranges between approximately 200 kWh/m³ for untreated pure urine and 15 to 20 kWh/m³ for diluted, biologically pre-treated urine. But for status without recolouring during subsequent storage conspicuously higher energy inputs were necessary (see figure 6-11). For this status energy needs for biologically pre-treated samples were remarkably lower than for untreated (factor 4 to 6).

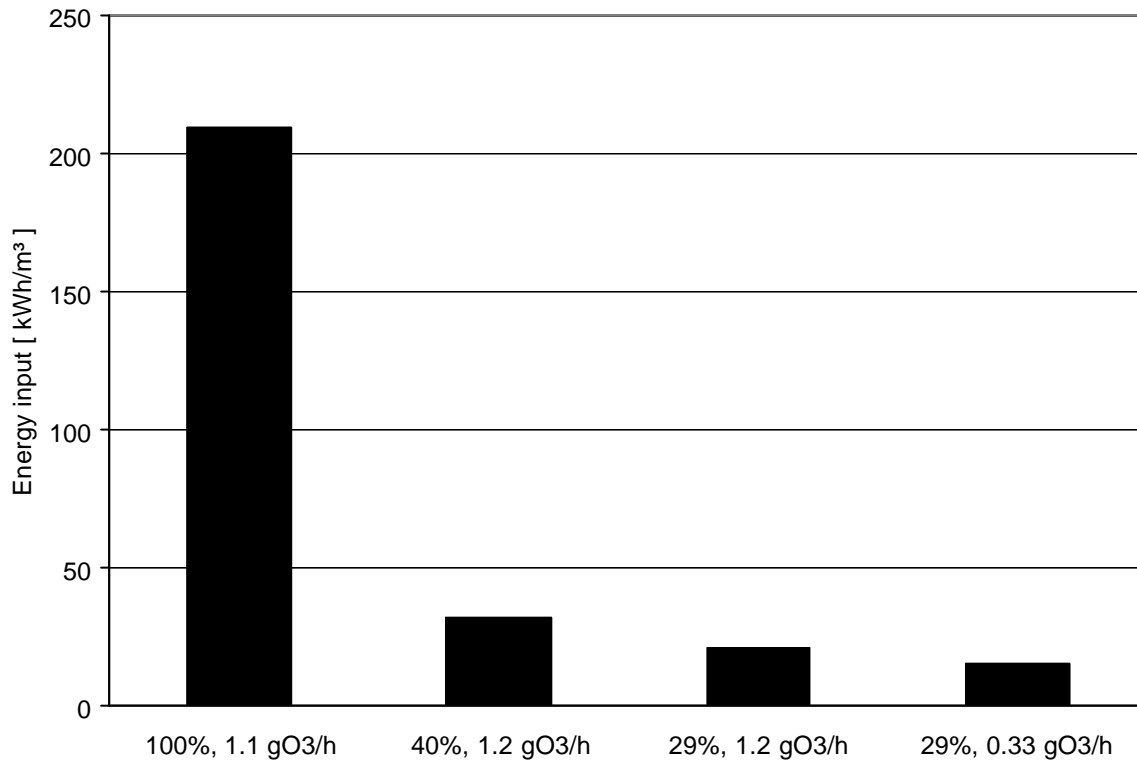

Figure 6-10: Energy input for colourless status with recolouring (100% and 40% samples untreated, 29% samples biologically pre-treated)

pH of untreated urine decreased during treatment (approximately 6.5 to 4), whereas pH of biologically treated samples remained around 8.5. During storage pH of untreated liquids increased during ozonation up to values between 7 and 9. Other samples remained stable also during storage subsequent to the ozonation.

Injection of gas into liquid caused stable foam. Treatment always eliminated this tendency to form foam. For untreated samples inputs of 11 kgO₃/m³ (150 kWh/m³) respective 14 kgO₃/m³ (200 kWh/m³) were necessary for foam-removal. In tests with biologically pre-treated samples just some minutes of ozonation (< 0.6 kgO₃/m³ respective < 10 kWh/m³) were sufficient for foam destruction.

Ozonation of fresh urine resulted in a slight vinegar smell, which disappeared during storage. Other samples showed no significant odour.

C* values of subjective colourlessness were in the middle about 1.5 (minimum: 0.9, maximum: 2.2).

Further data concerning these lab tests are given in the appendix (chapter 14.1, figures 14-4 to 14-5).

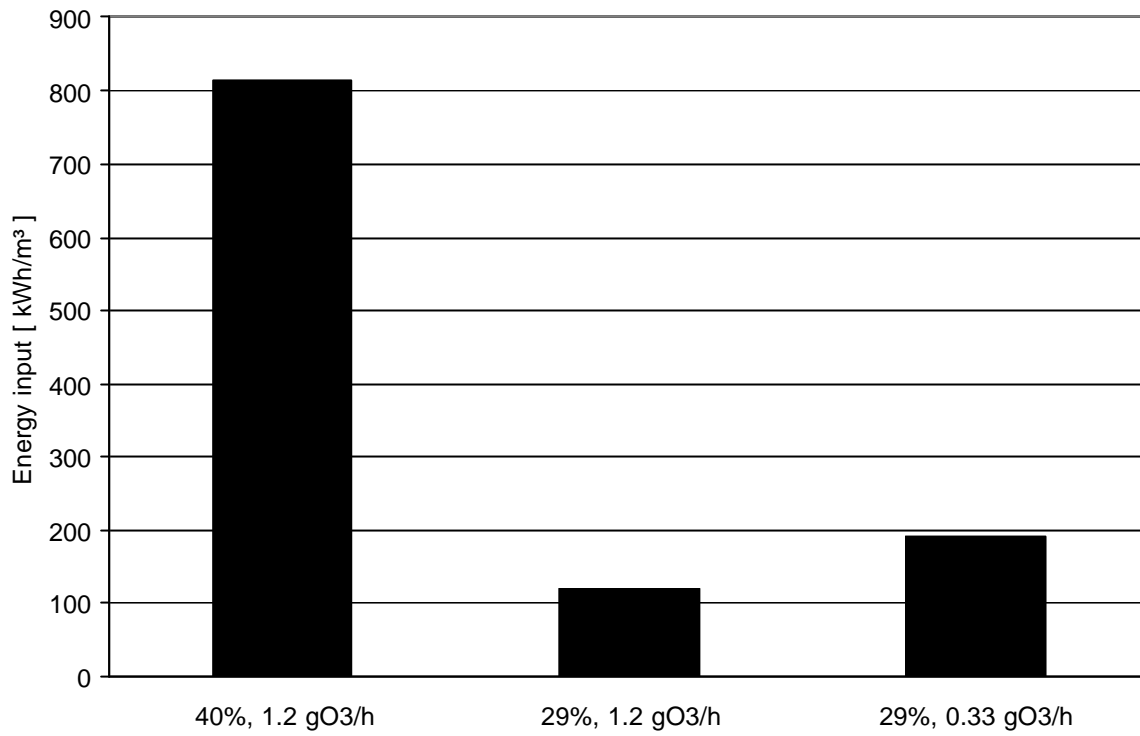

Figure 6-11: Energy input for colourless status without recolouring (40% sample untreated, 29% samples biologically pre-treated)

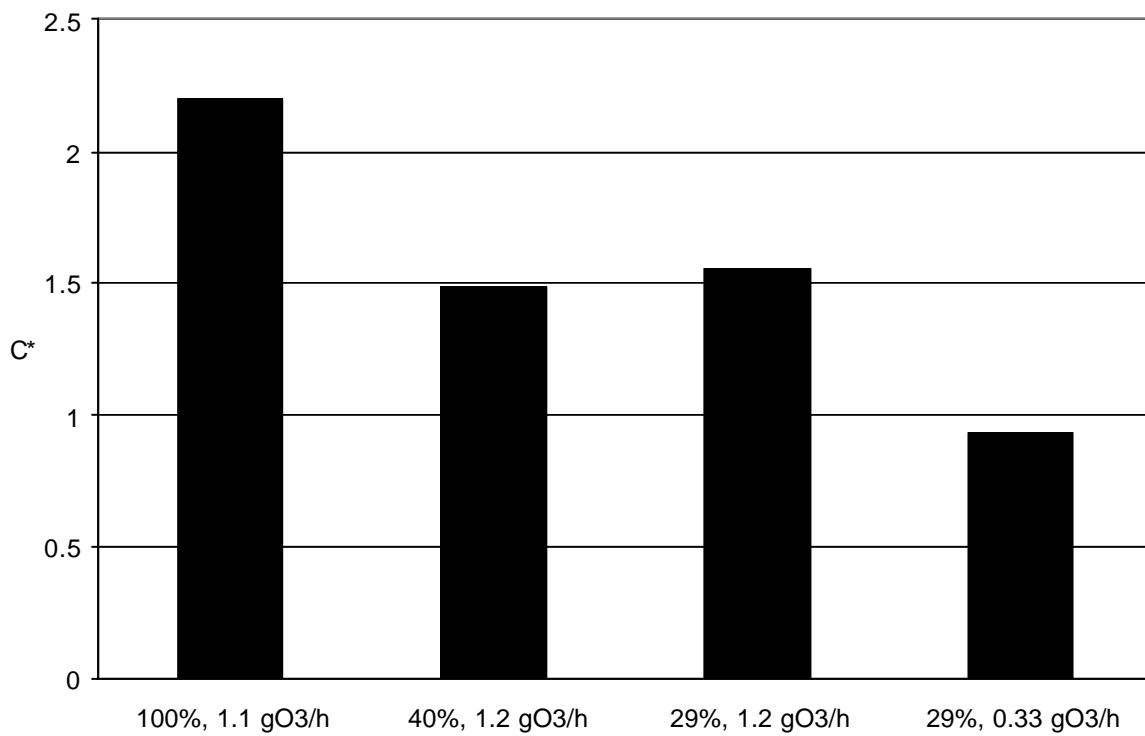

Figure 6-12: C* values corresponding with a subjective colourlessness after ozone treatment

6.3.4.2.2 Interpretation and Conclusions

Ozone is a possible option for decolourisation of urine. A relevant aspect for decolourisation with this technique is recolouring. To ensure a colour free liquid also during storage, ozonation beyond the point of first appearance of colourlessness is necessary. A direct possibility for a measurement or calculation of this additionally needed amount of ozonation was not found so far. May be further tests can provide sufficient data to create an empiric rate or ozone amount for this. Other possibilities would be to accept a slight recolouring or to prevent this recolouration by additional decolourisation in storage tank. This recolouring is reduced significantly by biological pre-treatment.

The sample with no recolouring of second test with biologically pre-treated yellow water was taken subsequent a longer period without sampling. This might have resulted in a longer treatment than necessary for this status. Evaluation of former decolourisation effect (higher efficiency than in first test with biologically pre-treated liquid) leads to the assumption that an energy input of 119 kWh/m³ (value of first test) or even lower would have been possible, because C* value of the prior sample (energy input of 42.4 kWh/m³, C* = 0.38) was just slightly higher than of the final sample (energy input of 190.6 kWh/m³, C* = 0.36).

Energy demand for decolourisation without recolouring is high. Reactor design was simple and mainly adapted on problems concerning foam. Another type of reactor (spray reactor, contact bed reactor) and/or reactor design may lead to lower energy consumption, because of better ozone utilisation.

Average value of C* for subjective colourlessness was about 1.5.

6.4 Systematic Precipitation respective Crystallisation

Systematic precipitation respective crystallization are technical options to prevent clogging of pipes or damaging of pumps, valves or membranes by deposits of salts in unsuitable parts of the system. Furthermore usable solids with high nutrient content can be produced and sold and thereby improve the profitability of the system. So this aspect is important for the BWL and therefore was selected to be investigated in a separate dissertation at the Institute of Wastewater Management and Water Protection of the TUHH focussing on this partial topic only. For this reason just some relevant remarks will be given in this thesis.

Precipitation and Crystallisation are both possible options for BWL.

Further information on the experimental set-up of the pilot plant and results of related literature reviews can be found in chapter 7.4.

MAP (magnesium ammonium phosphate, also called struvite) is a good possibility for a nutrient rich product for agriculture (one possible usage for these solids), as MAP is a long-term fertiliser which already is in use (e.g. in Japan [de Graaff, M. S. et al., 2007]).

For good performance of struvite formation next to high concentrations of magnesium and phosphorous also a sufficient concentration of ammonium is needed in the liquid. In fresh urine only minor quantities of ammonium are present, but it is produced by decomposition of urea by an enzyme called urease. To ensure sufficient ammonium concentrations in the precipitation respective crystallisation unit necessary conditions for this ureolysis had to be examined. Investigations [Lohmann, T., 2004] found short retention times to be sufficient if reactor is inoculated with urease respective urease generating bacteria. To ensure necessary bacteria retention a fixed bed system was

suggested. Further recommendation was to use a not aerated system to prevent formation of nitrite and nitrate. Generation of nitrite or nitrate would reduce ammonium concentration again and hence would be counterproductive.

Experiments with untreated urine and additions of different rates of magnesium (from 0, 50, 400, and 1000 mg/l added as MgO) have been carried out to measure phosphorous removal in liquid phase [Lindner, B., 2001]. With increasing Mg addition also removal efficiency increased. Samples were shaken for between 1 hour and 18 days. Because produced solids could not be analysed, no data concerning type of crystals and recovery rate of added magnesium can be displayed here. Other tests with MgO as precipitation agent found a rate of 1.5 between magnesium and phosphorous as optimal value [von Wolffersdorf, S., 2004] to reach high rates of P recovery from urine.

For recovery of phosphorous from waste water or sludge several techniques are under development [Brett, S., et al., 1997; Donnert, D. and Salecker, M., 1999; Kaschka, E. et al., 2005; Moriyama, K. et al., 2001; Pinnekamp, J. et al., 2003; Stratful, I. et al., 1999; Udert, K. M., 2002] respectively already do exist as fully developed systems for this purpose [Giesen, A., 1999]. In Japan even a full scale plant for recovery of P is already in use [Ueno, Y. and Fujii, M., 2001].

6.5 Overall Interpretation of Lab Scale Tests

Subsequent to an adequate adaptation phase the biological treatment of the liquid was possible also for increasing salt and nitrogen concentrations. The liquid resulting from this biological treatment was nearly free of odour and very stable regarding colour, although colour became darker during treatment.

Treatment of urine with ozone results in an uncoloured liquid. Amount of ozone needed for this result depends next to concentration (in cases of diluted urine) also on pre-treatment. Biological pre-treatment reduced the ozone demand significantly. Additionally the problem of recolouring during subsequent storage can be reduced by biological pre-treatment.

Use of UV light including 185 nm is a technical option for decolouration of urine, but energy demand is much higher than in case of treatment with ozone. An advantage compared to ozone is the fact that no recolouring appears after samples have reached colourless status.

Reactor used for UV treatment including 185 nm was a professionally designed, thin film reactor. An optimization of the reactor design, if at all possible, will not lead to a significant energy economization. The design of the used ozone reactor is much simpler. Here use of an optimized reactor respective another reactor type is expected to lead to substantial reduction of energy demand for decolouration. Hence use of professionally designed equipment will increase differences regarding energy efficiency between UV and ozone treatment. Regarding this aspect ozone is the better solution. Just if usage of ozone is not possible because of safety or technical reasons, UV treatment could be an alternative. Standards for evaluation of colourlessness have been very strict during these tests (bright light, sample evaluated in front of a white piece of paper). For reuse as flushing toilet a slight remaining colour or slight recolouring may be acceptable. This would lead to energy savings for both technologies.

To get values for the design of further plants a calculation of the energy demands per percent urine in the liquids (e.g. multiplication of these values with 100 for pure urine) seem to be suitable. Despite of the differences regarding biological pre-treatment and the applied decolourisation technology these values still vary greatly. A further separation regarding decolourisation with respective without

recolouring during storage shows the big energetic difference between these two product levels for the application of UV radiation. A general trend if higher or lower concentrated liquids can be decolourized more energy efficient can not be extracted from the available results.

Table 6-2: Energy demand for the complete decolourisation per percent of urine content of the sample

Treatment technology	Unit	Biological pre treatment		No biological pre treatment	
		recolouring	no recolouring	recolouring	no recolouring
Ozone	[kWh/(m ³ *% of urine content)]	0.5 - 0.7	4.1 - 6.6	0.8 - 2.1	20.4
UV-C radiation	[kWh/(m ³ *% of urine content)]	-	24.3 - 53.8	-	147.4 - 238.5

Colour of samples was measured by colourfulness (C*) according to German standards. C* values found to be subjective free of colour ranged between 0.7 and 3.8 for UV (average: 1.5) and between 0.9 and 2.2 for ozone treatment (average: 1.5). So for both technologies samples of a value below 1.5 normally are free of colour. Below 1.0 there is a high likelihood that a sample is subjectively colourless.

First step for removal of odour is to remove solids (in cases of black water samples). A biological treatment of yellow water respective BWL liquid is sufficient to remove odour completely. Further conditioning of liquid by UV irradiation or ozone results in just very slight or even no smell. Subsequent storage (after the treatment by UV or ozone) also no odour could be observed.

To prevent blockages or damages by salt deposits and to produce a dry material for fertilizer production or other purposes a systematic precipitation or crystallisation would be suggestive for the BWL. Performed lab tests show that a systematic precipitation is possible. In literature plenty of possible technologies are listed and even ready designed components and examples of successful working full scale plants are given (see references in chapter 6.4). Hence, it can be stated that a solution for the black water loop can be found here by either application of existing systems or development of a new adapted set up.

Experiments regarding deposits in toilets resulted in no indications that longer phases without use do cause relevant problems.

7 Experiments with Pilot Plant

Main objective of the operation of this pilot plant is to prove the technical feasibility. Furthermore technical components like the membrane, the riddle screen, the UV reactors, and the sensors will be tested in a direct context to each other. The prepared control system will be tested and improved during the plant operation.

The implementation of this plant will also allow to search for technical obstacles and to check the acceptance of the system with users from the AWW Institute.

Furthermore liquid for additional lab scale experiments and biomass for inoculations of biological treatment units of further plants will be generated.

The different treatment steps of this plant are described and discussed in this chapter following the flow of the liquid.

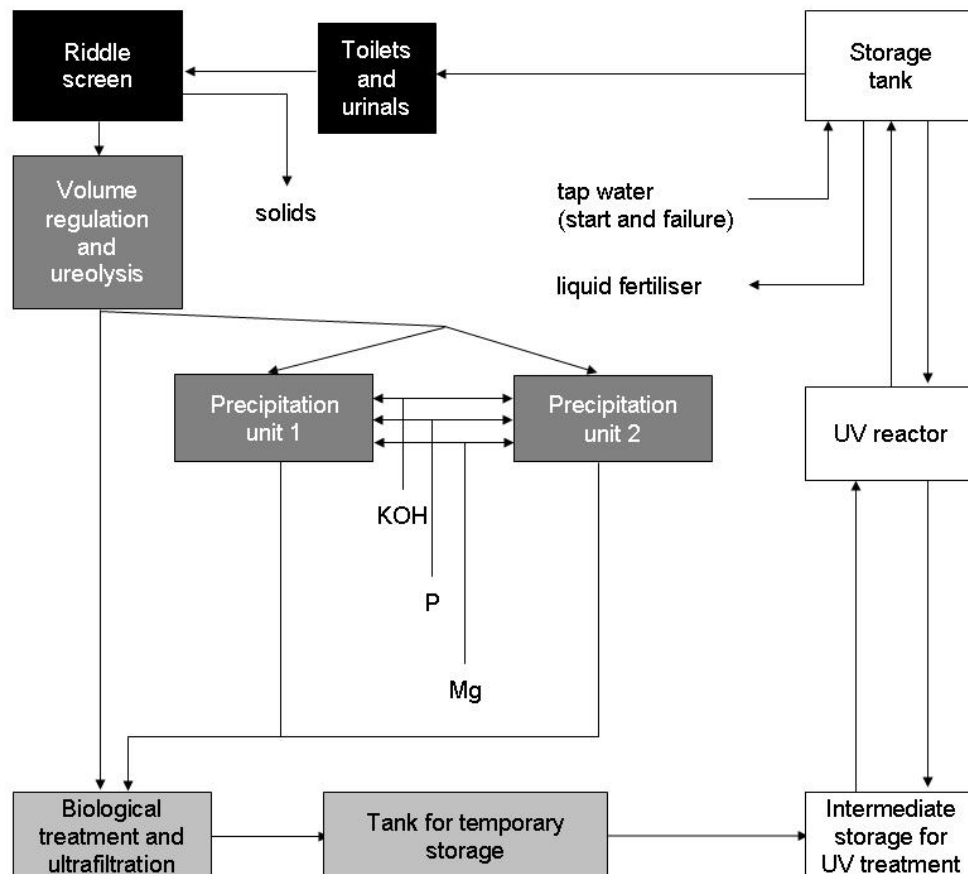

Figure 7-1: System sketch of the used pilot scale black water loop

7.1 Collection of Source Separated Flows

For the implementation of the pilot BWL in the Institute of Wastewater Management and Water Protection of the TUHH separate sanitary facilities have been installed. These facilities are used only by the institute members (at maximum about 13 persons, approximately one half each female and male) and a few student co-workers.

One toilet and a waterless urinal are connected to the BWL. The toilet possesses no special surface coatings (lotus effect). The toilet tank is built with a water stop function for reduced water use (e.g. usage without defecation). A complete use of tank content means a use of approximately 9 litre of water. The waterless urinal possesses a siphon. The oil in the siphon covers urine to prevent odour. The urinal was connected to the BWL to reach a higher urine input with the rather small number of users (minimising uses of other urinals in the building by male members of the AWW Institute). Higher urine input results in a quicker increase of yellow water content (more difficult decolourisation and quicker achieving of maximum concentrations). For a normal implementation without scientific ambitions a separate collection of urine from waterless urinals would be the best solution to minimize energy demand for decolouration.

To be able to give statements regarding utilization of BWL, the number of usages is counted by a push to a button. In the toilet cabin buttons for black water and yellow water use are installed. Further inflow of fresh water (filling and failure phases) and the liquid consumption of the toilet are measured by water meters.

The pilot BWL was in use during 116 working days (224 days in total). Overall 455 uses of the toilet (266 black water uses and 189 for just urination) and 379 utilisations of the urinal took place during this experimental phase. For working days (8 to 10 hours per day) this means an average of 0.4 – 0.5 toilet uses per hour (0.2 – 0.3 for urination and defecation and 0.2 for just urination) and 0.2 – 0.3 uses per hour for the urinal.

The approximate volume of the plant tanks and tubes is about 1.0 m³. During experiments 3.72 m³ of flushing water was used for the toilet. This is an average of about 8.2 l per use. This demand results in a calculatory cycling rate of the water in the BWL of about 3.7 times. Increase of urine concentration was quicker than the cycling rate would suggest, because of the waterless inflow of urine from the urinal. Losses of liquid appeared as side effect of the solid separation (see chapter 7.2), extraction of liquid for lab tests, and because of evaporation and technical problems.

After several weeks the siphon of the urinal had to be changed because odour appeared. The oil of the siphon was removed, because of a too small tube (18 mm diameter) was attached to the urinal. The urine flowed through the tube and caused a vacuum, which sucked the oil out of the siphon.

No noteworthy depositions in the toilet or blockages of pipes appeared. But this topic should be observed in future investigations also, because blockages of pipes in urine collecting systems are an often observed problem [Udert, K. M. et al., 2003b] and therefore remain to be of interest for implementations of the BWL.

7.2 Solid Separation

Next to the basic function to separate the solids this treatment step is additionally applied to protect the membrane of the biological treatment step (see chapter 7.5).

7.2.1 Description and Results

In the experimental setup solid separation was done by a riddle screen (SWECO riddle screen LS18S33, sieve with mesh size of 0.128 mm). In the literature pre-treatment with sieves or riddle screens with mesh sizes smaller than 0.5 mm are described as useful to prevent problems with the membranes (hair or fibres) [Cornel, P. and Krause, S., 2006]. For separated solids 21 measurements of dry matter were conducted (measurements according to German standards DIN 38409, method DIN 38409-H1-1), 3 samples each). Found values for dry matter (DM) vary greatly between 0.5 and 11.9% (average of 3.7%). Depositions of toilet paper on the sieve led to clearly increased amounts of liquid in the extracted solids. Regular checks regarding this issue are necessary to reach high DM respective low losses of liquid.

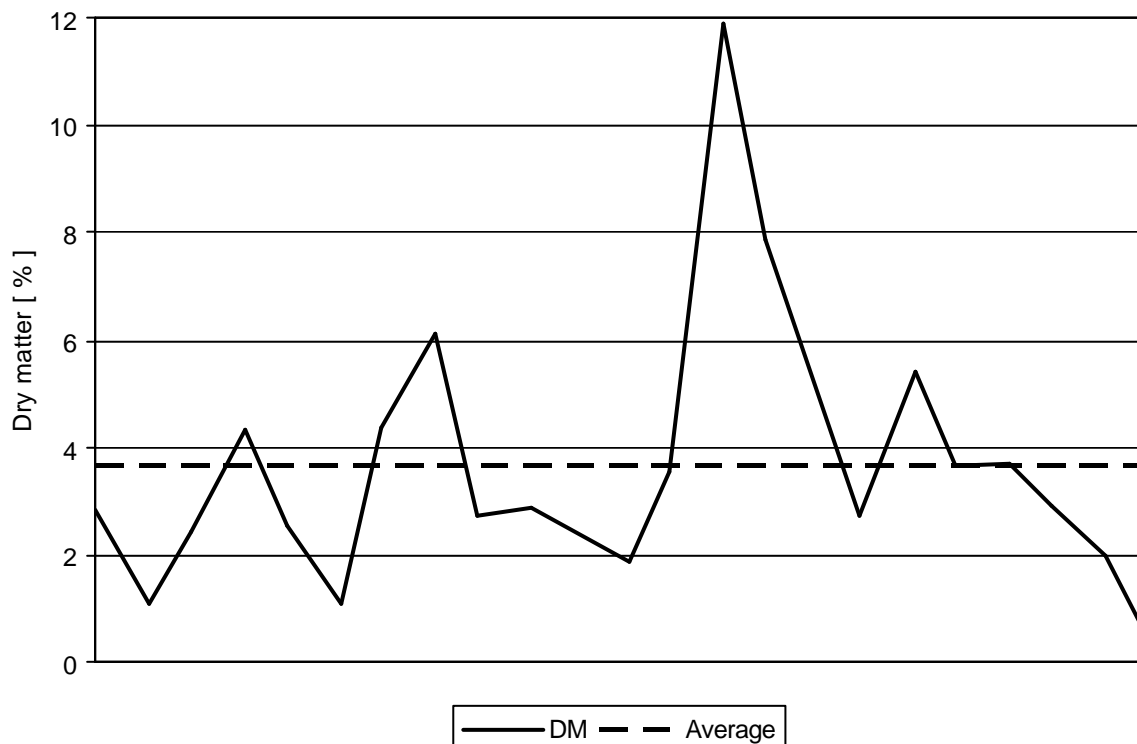

Figure 7-2: Dry matter of separated solids

The sieve was made of stainless steel. Although at the end of experiments larger parts of the sieve was blocked by rust. An effect of this blockage on the DM is probably. The manufacturer of the sieve states that even with these high salt concentrations rust normally does not appear. Further investigations with a new sieve with a higher mesh size of 0.5 mm are currently ongoing. Scope of these tests is to increase the dry matter of the solids. Higher carbon inflow into biological treatment, resulting of a less

sharp separation of solids, is not assumed to be problematic, because of sufficient capacities in biological treatment step and the high N:C-ratio of the liquid.

7.2.2 Interpretation and Conclusions

The riddle screen is a technically possible solution for the BWL. DM varied greatly during experiments. Further detail investigations are necessary to find the optimal mesh size for this application. Use of toilet paper can cause lower DM of separated solids, if it is not removed sufficiently by movement of sieve.

7.3 Volume Regulation and Ureolysis

An equalisation of the plant inflow is beneficial, because of the considerably variations in the toilet use. According to the results of pre-tests (see chapter 6.4) a not aerated tank with fixed bed material is a useful solution for the ureolysis. Retention time of 30 minutes is sufficient [Lohmann, T., 2004]. Ureolysis must be located before the precipitation respective crystallisation to ensure high ammonium concentrations for these treatment steps (see chapter 6.4 and 7.4). These circumstances show that a combination of inflow regulation and ureolysis in one tank are possible and can decrease plant volume and save money. Just volume reduction by introduction of fixed bed material has to be considered for flow equalisation.

Ureolysis is the process of the hydrolysis of urea to ammonium, ammonia and hydrogen carbonate:

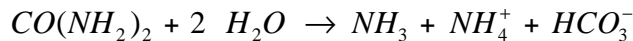

As result of the ammonia release, pH increases during ureolysis. This reaction mainly is enabled by the enzyme urease (urea amidohydrolase). A second known enzyme which enables hydrolysis of urea is called urea amidolyase. It is produced by yeasts and algae [Mobley, H. L. T. and Hausinger, R. P., 1989; Udert, K. M. et al., 2003b]. Additionally non-enzymatically urea decomposition is possible (half life time of 3.6 years at 38°C) [Andrews, R. K., et al., 1984; Udert, K. M. et al., 2003b]. The last both processes are negligible here because of widely spread presence of ureolysing bacteria [Udert, K. M. et al., 2003b].

7.3.1 Description and Results

In this plant the combined volume regulation and ureolysis reactor is made of a 200 l tank and a free swimming net filled with plastic fixed bed material (volume: approx. 650 ml, material name: PURAK). The top cover is sealed by a band of foamed rubber to minimize odour. The pH value is measured in this tank.

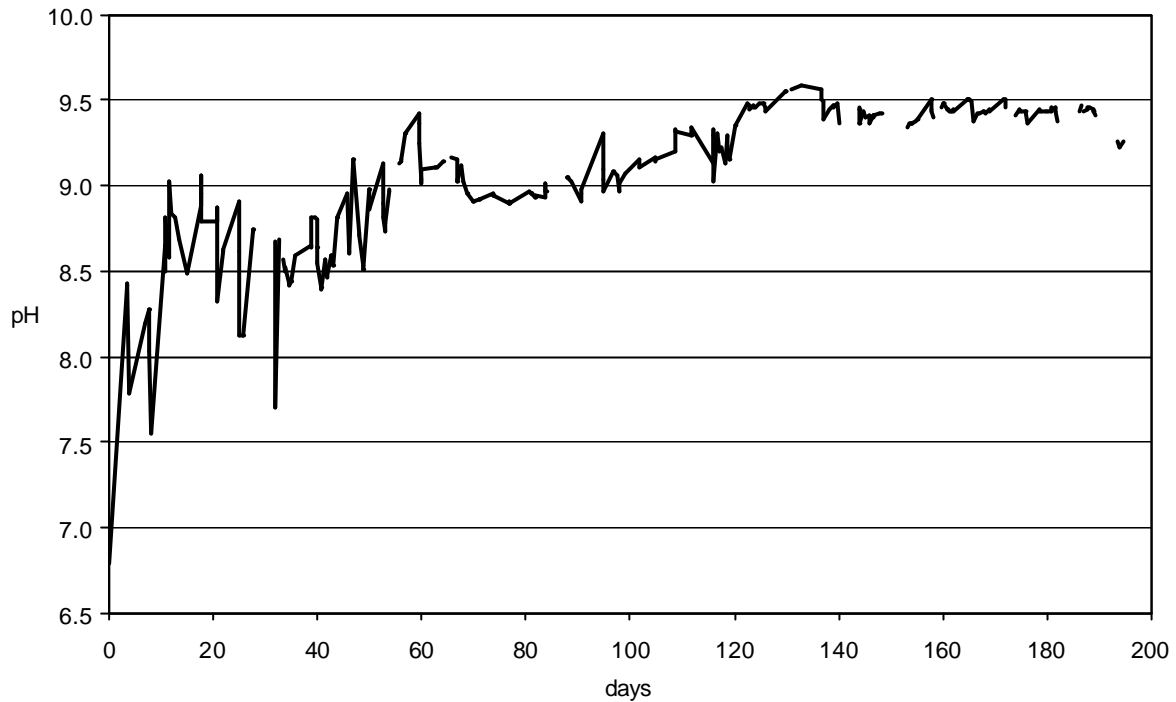

Figure 7-3: pH in equalisation tank during experiment

7.3.2 Interpretation and Conclusions

Just if cover was lifted a significant odour of ammonia appeared near by the treatment unit. Sealing with foamed rubber was sufficient protection against smell.

For flow regulation the free volume of approximately 200 l was sufficient for this intensity and variation of use.

At the beginning the pH value is with a value of 6.8 in the neutral range but increases rapidly to a value between 8.5 and 9.0. Subsequent the pH stabilised at a value slightly lower than 9.5. The high pH is caused by the ureolysis (see chapter 7.3).

The inflow of fresh black water leads to variations of the pH.

Missing values have been results of very low liquid levels in the tank, caused by the varying inflow.

The increasing pH as consequence of the ureolysis can cause precipitation of calcium phosphate, struvite and calcite. Udert [Udert, K. M. et al., 2003a] gives values of about 30% for losses by precipitation during ureolysis. Because the treatment units are still in use no check for precipitated solids in the tank has been possible so far.

7.4 Precipitation respective Crystallisation and pH-Adjustment

The extraction of solid fertilizer raw material from the BWL can either be done by a precipitation or a crystallisation step. Research on this topic is except to some pre-tests (see chapter 6.4) explicitly excluded from the work of this thesis. It will be topic of another dissertation in the AWW Institute. So in this chapter mainly the feasibility is shown by results of a literature review and the influence of the exception of its operation from this thesis on the operation of the remaining test plant is described.

This treatment step is located subsequent to the solid separation and ureolysis. Hence, a contamination of the produced crystals with coarse solids is prevented. Furthermore, as shown by previous investigations the antecedent ureolysis is beneficial for a precipitation [Udert, K. M. et al., 2003b].

Even without own pilot scale experiments regarding this issue, it can be stated that suitable technologies are available to fulfil this function. An increasing number of suitable technologies for precipitation [Kaschka, E. et al., 2005; Pinnekamp, J. et al., 2003; Udert, K. M. et al., 2003b] as well as for crystallisation [Brett, S., et al., 1997; Donnert, D. and Salecker, M., 1999; Giesen, A., 1999; Pinnekamp, J. et al., 2003; Stratful, I. et al., 1999; Wagner, M. and Henkel, J., 2006] is listed in literature. For some of these techniques even large scale plants are already implemented [Moriyama, K. et al., 2001; Ueno, Y. and Fujii, M., 2001]. Investigations regarding different types of waste water have been carried out [Donnert, D. and Salecker, M., 1999].

To initiate the precipitation pH is increased by a base. So this partial flow subsequent can be used to keep the pH of the biological treatment step (decrease of pH in biological treatment as consequence of the nitrification) in an optimal range.

The tobermorit ($\text{Ca}_5[\text{Si}_3\text{O}_8(\text{OH})]_2 \cdot 2\text{-}5 \text{H}_2\text{O}$) induced crystallisation causes an increase of pH as well [Wagner, M. and Henkel, J., 2006] and so provides this advantage too. For other crystallisation techniques the pH adjustment need to be done directly by addition of a base.

In systems with yellow water (subsequent to the solid separation the liquid of the black water loop from the chemical point of view is similar to yellow water) often magnesium ammonium phosphate (MAP) or octacalcium phosphate (OCP) respective in the long run hydroxyapatite (HAP) precipitates [Udert, K. M. et al., 2003b].

The use of a crystallisation technique reduces the amount of salts in the liquid and thereby inhibits uncontrolled precipitation in the system. However, the subsequent addition of a base increases this content again. For the precipitation an increase of pH is inducing. So the reduction of the salt content by precipitation itself is at minimum compensated by the addition of the base.

For the applicability of the product a low rate of contamination is advantageous. Crystallisation techniques can fulfil this need [Giesen, A., 1999; Ueno, Y. and Fujii, M., 2001].

Because of limited availability of phosphorous and increasing contaminations with heavy metals of the remaining sources the need for such a kind of raw materiel for fertilizer production will increase [Bundesregierung sieht Chancen für Phosphorrecycling, 2006; Gethke, K. et al., 2005a; Pinnekamp, J. et al., 2003].

Investigations [Goldbach, H. E., 2004] showed that for MAP availability of the nutrients for plants is good. In Japan MAP (as well as MPP - Magnesium potassium phosphate) is already in use as fertiliser [de Graaff, M. S. et al., 2007]. But so far in Germany the use of this MAP is not allowed for fertilizer

purposes. But until this legal obstacle is removed, it can be used as raw material in the washing agent production as well [Gethke, K. et al., 2005a].

7.4.1 Description and Results

Because the other mentioned dissertation on the black water loop is planned to start with experiments on precipitation in a partial flow, the plant set up is prepared for this technique.

The set up of the precipitation unit consists of two tanks. Liquid from the ureolysis tank alternately is pumped into one of these bowls. Subsequent to the filling phase up to three different liquid chemicals can be added by pumps. One of these liquids is a base (planned NaOH or KOH). The other two storage tanks contain a phosphorous respective a magnesium solution. So experiments with different ratios of nitrogen, phosphorous and magnesium can be enforced. The outlet of the tanks is located at the bottom. On its way to this outlet the liquid must pass a coarse geotextile filter bag. This filter removes the precipitated solids from the liquid before it is pumped into the biological treatment step. The geotextile can be removed from the tanks and the filtered crystals on the surface of the filter can be dehisced and separated by deformation of the flexible filter material. Subsequent the geotextile bag can be used in the precipitation unit again. The pump at the outlet of the precipitation unit is controlled by a pH measurement in the biological treatment step.

One test run was carried out with this treatment step. Just KOH (1 mol / litre) was added here. After half an hour the pump at the outlet began to remove the liquid again (depending on pH of the biological treatment step). After the tank was evacuated, a thin layer of white crystals was visible on filter material. No analysing of the produced material was undertaken for this testing.

Because investigations on this treatment unit did not start before the experiments of this dissertation were finished, the pH adjustment for the biological treatment step (see chapter 7.5) was ensured by manual additions of NaOH respective KOH.

7.4.2 Interpretation and Conclusions

In the literature several already investigated possible techniques can be found, which would be feasible solutions for the removal of nutrient crystals from the liquid of the black water loop (see introducing chapter 7.4).

A precipitation is accompanied with a change of pH. For this case a pH decrease would not be useful (need for increase of pH of biological treatment step). So a base will be added (respective was added during test run).

During a test run addition of KOH resulted in the retention of white crystals on the surface of the geotextile. The results of other [Udert, K. M. et al., 2003c] investigations lead to the assumption that it might mainly consist of magnesium ammonium phosphate (MAP), octacalcium phosphate (OCP) or hydroxyapatite (HAP). Further possible crystals are described in medical investigations regarding kidney stones (a kind of non technical precipitation, see chapter 3.1.2).

7.5 Biological Treatment and Membrane Filtration

The two main objectives of the biological treatment of the liquid are to reach a biologically stabilized liquid and to remove the odour, like it was reached during the lab scale experiments (see chapter 6.1). A relevant part of the smell elimination is done by the removal of ammonia. This will be reached by oxidation up to nitrite respective nitrate.

The removal of remaining solids is ensured by a submerged ultrafiltration membrane. Additionally the membrane removes (pathogenic) germs. Investigations at several waste water treatment plants proved that the limits of the EU bathing water directive are complied by micro- respective ultrafiltration of municipal waste water [Weltgrößte kommunale Membrankläranlage in Betrieb, 2004; Abwasserreinigung mit Membrantechnik, 2003; Harms, M. and Englert, R., 2006; Schleypen, P. and Hruschka, H., 2004]. The pore sizes of micro- and partially even ultrafiltration membranes are bigger than some viruses (see figure 7-4). Nevertheless, in most cases even viruses are removed by the membranes, because these normally stick to bigger particles. During longer use of membranes a slight increase of the number of germs in the permeate may appear [Back, E. et al., 2005].

A second security regarding removal of pathogenic germs is the decolourisation and disinfection by UV radiation respective ozone. So the disinfection in the black water loop is ensured by two separate systems. All tests regarding hygienic safety are described and discussed in chapter 7.6.

Membrane systems	reverse osmosis		nanofiltration		ultrafiltration		microfiltration									
	100	200	10,000	20,000	100,000	500,000	[Dalton]									
Molecule weight																
Approximate particle respective molecule size	0.001		0.01		0.1		1.0 [µm]									
Examples	metal-ions		antibiotics	salts	tensides	sugar	reactive dyes	enzymes	viruses	fat and oil emulsions	gelatin	endocrine substances	pigment dyes	bacteria	activated sludge flocs	barm

Figure 7-4: Substances removed by the different membrane systems, Dalton: Numerical equivalent of the molecular weight [g/mol], figure according to [Abwasserreinigung mit Membrantechnik, 2003]

7.5.1 Description and Results

The biological treatment unit consists of an uncovered tank of a volume of approximately 490 l (h_{total} 125 cm ($h_{liquid,max}$ 108 cm) x 50.3 cm x 90 cm). The size of the tank was selected according to the dimensions of the membrane system. It was the smallest available system of the project partner company Hans Huber AG (manufactured by the company Martin Systems GmbH). The system is a vacuum upstream membrane (type: 2 VUM A11). Additional data of the system is given in table 7-1.

Table 7-1: Technical description of membrane system

System	Ultrafiltration, $d_{\text{pore}} < 0.05 \mu\text{m}$
Surface	Two modules of 2 m ² each, 25 plates per module
Material	Poly Acrylic Nitrile (PAN)
Maximum gross flow	480 l/d
Maximum gross flux	15 l/(m ² *h) at a maximum trans membrane pressure of 0.3 bar
Cross flow aeration	4.5 m ³ /h
Boundary value of operation	pH range: 2 – 10, temperature range: 5 – 60°C
Chemical cleaning (suggested)	Every 4,400 h of use (approx. ½ year)
Pre treatment	Sieving with at maximum 1 mm pore size (manufacturer instruction)

The median value of the net flux is about 0.17 l/m² * h (about 1.4% of maximum gross flux, no smaller unit available). No chemical cleaning of the membrane was done during experimental phase.

Aeration of the biological treatment unit is done by fine bubble aeration at the bottom of the tank and the coarse cross-flow aeration of the membrane module.

The inoculation bacteria were produced during the lab scale tests and for this reason have been already adapted to high yellow water concentrations (see chapter 6.1). To generate additional biomass before the toilet use could be started, a controlled feeding with increasing amounts of yellow water took place. At the beginning of the real plant operation the concentration was increased up to nearly 50 mg DM per litre, but the main amount of the biomass was fixed on the walls of the tank. During plant operation the amount of total solids of the liquid phase increased up to a value of about 1.0 g/l, but a biofilm (not quantified in these measurements) has been observed. No sludge was extracted during the experiments.

Because the experiments with the precipitation unit (see chapter 7.4) have not been started before the end of these investigations, the pH control was done manually by NaOH respective KOH. The value of the pH in the middle was about 7.6.

During feeding with yellow water (prior to the plant start, phase I) about 0.5 l sodium hydroxide solution (1 mol/l) per 1.0 l of yellow water was needed to keep the pH stable.

In the phase of plant operation (inflow from toilet use, phase II) an average of approximately 100 ml potassium hydroxide (1 mol/l) or about 80 ml of sodium hydroxide (1 mol/l) per each use of the toilet or the urinal were needed to keep the pH between 7.5 and 8.5. The ratio of 0.8 between these two substances was also found during titration tests (triple determination) with liquid from the black water loop system.

The temperature of the liquid in the biological treatment tank varied between 9.8 and 22.7°C. The values below 12°C just appeared during Christmas holidays with low inflow from the toilets.

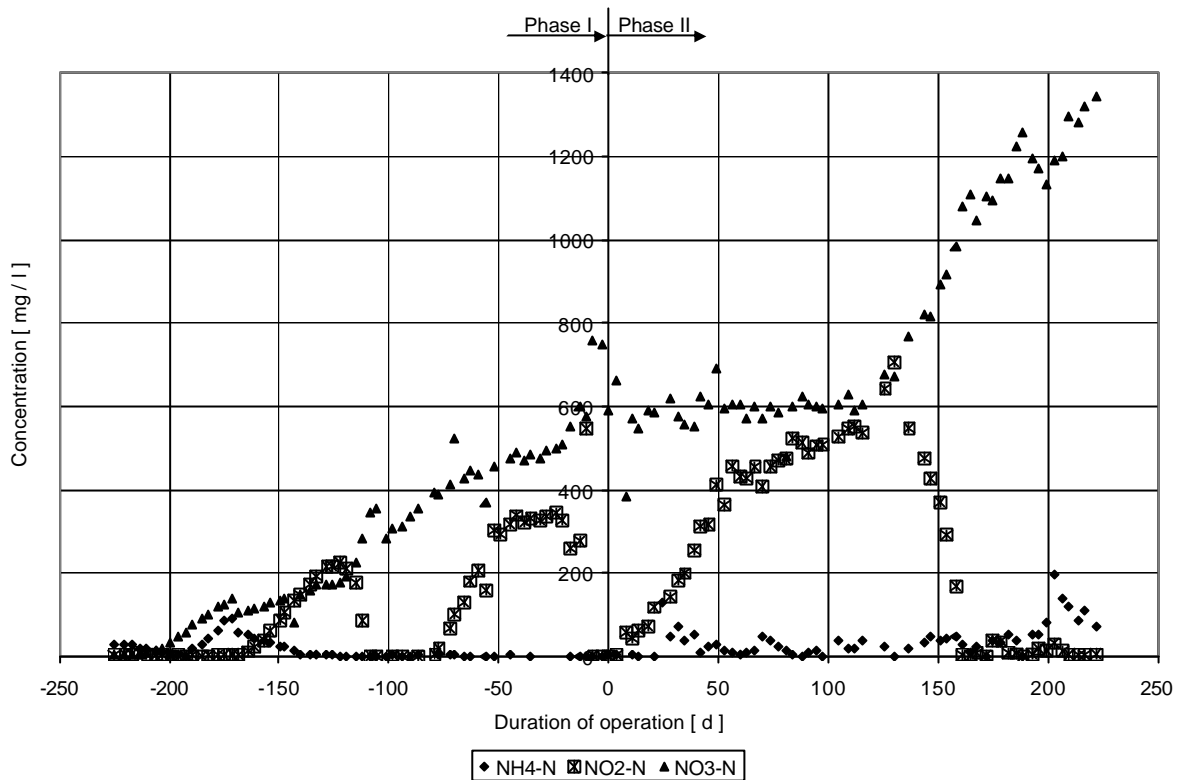

Figure 7-5: Ammonium, nitrite, and nitrate nitrogen concentrations in the liquid of the biological treatment unit

The concentrations of ammonium mainly were below 60 mg/l. During phase I the value mostly was below 2 mg/l (addition of yellow water was done discontinuous subsequent to sampling).

Nitrite nitrogen concentrations for three times increased up to levels of about 225 and 550mg/l (phase I) respective 710 mg/l (phase II).

During phase I nitrate nitrogen concentration increased up to a level of about 600 mg/l. At the beginning of phase II there was a temporary stagnation (approximately 115 days). Subsequent values increased again up to nearly than 1400 mg/l at the end of the plant operation.

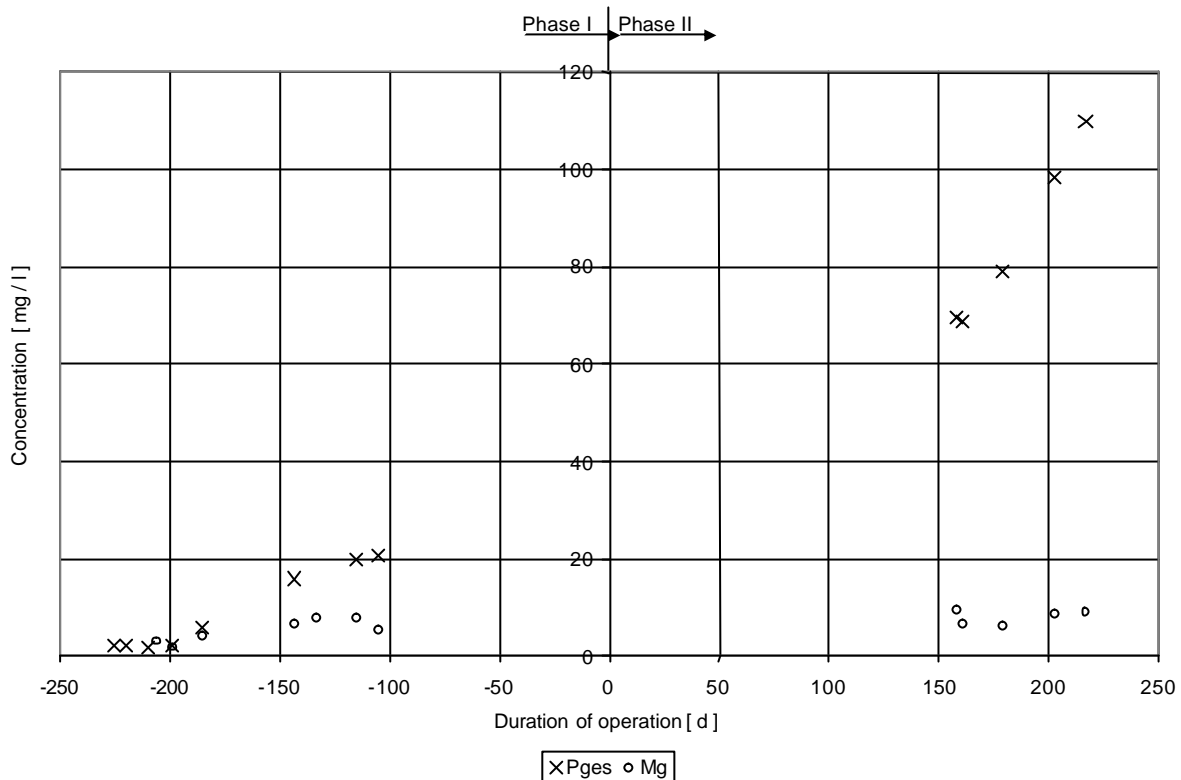

Figure 7-6: Magnesium and total phosphorous concentrations in the liquid of the biological treatment unit

During the phase of yellow water feeding as well as during the time of real operation the concentration of phosphorous increased from a value of 2 mg/l up to 110 mg/l. In the same time magnesium remains nearly stable at a value of below 10 mg/l.

Sometimes huge amounts of stable foam were generated in the tank.

The colour of the liquid in the tank quickly became dark brown. Subsequent to the membrane filtration it was bright yellow.

During the whole phase of operation no significant odour appeared.

7.5.2 Interpretation and Conclusions

The dimensioning was done according to admeasurements of the membrane module, the aeration element, and the measurement installations. Hence, an optimisation according to common dimensioning rules was not possible and the biological treatment tank as well as the membrane surface were oversized for the low inflow. The tank volume of over 450 l led to an average retention time of about 700 h (29 days). According to the literature [Cornel, P. and Krause, S., 2006; Gutttau, S., 2005] the minimum retention time for membrane bioreactors is at least 4 hours (175 times less).

The DM content of the liquid was low (less than 1 g/l) during tests, whereas the biological oxidation worked well (low ammonium and mostly low nitrite concentrations). The low amounts of activated sludge in the tank and the fixed biomass on the tank walls have been sufficient for a good and stable

performance. As result of the low utilisation rate no excess sludge has been generated and no extraction has been necessary.

Because no smaller module was available also the utilisation ratio of the membrane was low. The average net flow was 0.17 l/m²·h. According to manufacturer information the maximum gross flow for this membrane is 15 l/m²·h. With the standard settings (10 minutes of filtration followed by 3 minutes break) this leads to a maximum net flow of 11.5 l/m²·h. This means the average flow of 0.17 l/m²·h is just a ration of utilisation of 1.4% for the membrane.

During tests no chemical cleaning of the membrane was necessary. The salt contents in the black water loop can be expected to cause scaling on the membrane surface. This would lead to shorter intervals for the chemical cleaning. The low content of TS in this treatment unit on the other hand is a circumstance that leads to longer intervals [Guttau, S., 2005]. So the fact that no chemical cleaning was necessary during these experiments, can not lead to the assumption that it also will not be necessary for full scale implementations, because higher concentrations of total solid matter and higher flow rates through the membrane will appear in these implementations.

Aeration of liquids with high urine contents always leads to foam generation. The experiments in the lab scale as well as the tests with this pilot plant showed this fact, but by covering the tank this problem could be solved in a simple way here. With additional mechanical foam destruction at the air outlet also remaining foam discharges could be prevented.

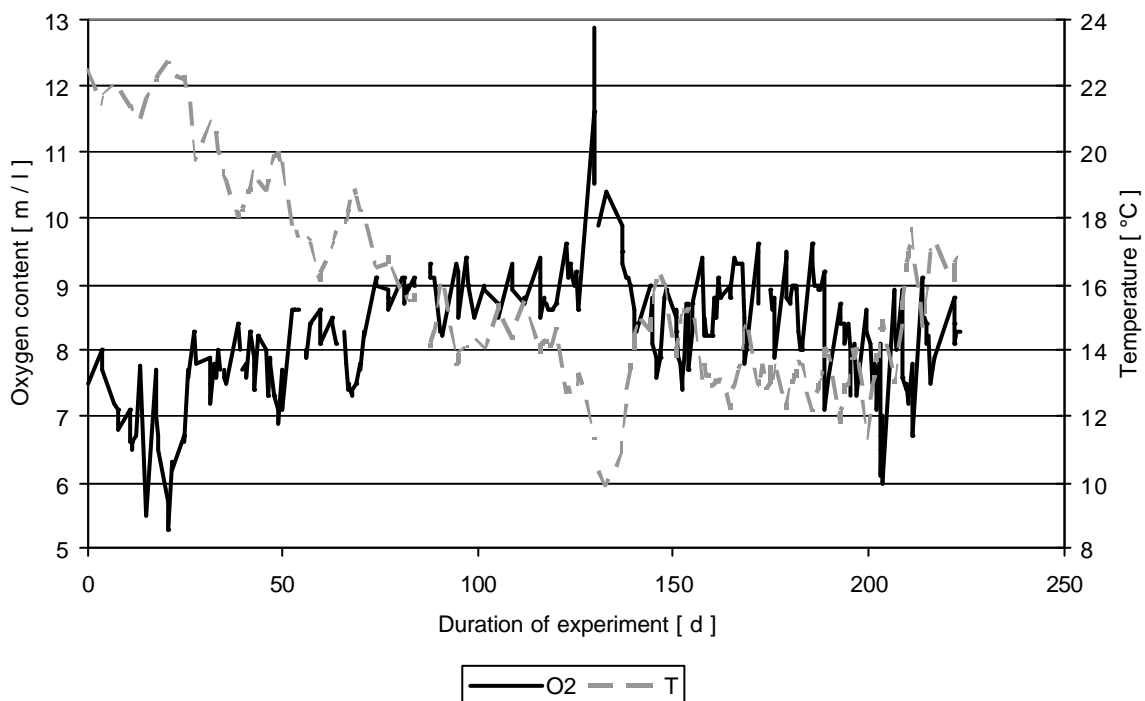

Figure 7-7: Oxygen content and temperature of liquid in the of biological treatment unit

Most of the time temperature was high enough for a sufficient nitrification. Temperatures of less than 12°C only appeared during Christmas holidays (down to 9.8°C, central heating of the building was switched of). Because of the also very limited inflow from the toilets during this time remaining nitrification potential still was sufficient.

The biological treatment step was continuously aerated by fine and during membrane filtration additionally by coarse bubble aeration. Because of the low utilisation rate the oxygen value in the tank nearly all the time was near the value of saturation. Figure 7-7 shows that the oxygen content correlates well with changes of temperature (temperature influences the value for the oxygen saturation).

The pH in the treatment step was kept stable by addition of potassium hydroxide (KOH, 1 mol/l) respective sodium hydroxide (NaOH, 1 mol/l). The necessary amounts (0.5 l NaOH (1 mol/l) per 1.0 l of yellow water respective 100 ml KOH (1 mol/l) or about 80 ml of NaOH (1 mol/l) for each use of the toilet or the urinal) are high and have to be well recognised for the cost calculation (see chapter 9). A complete nitrification of urine without control of pH is not possible [Udert, K. M. et al., 2003a].

Nitrite nitrogen concentration (see figure 7-5) for three times increased up to levels of about 225 and 550 mg/l (phase I: Up grow of biomass, feeding by yellow water) respective 710 mg/l (phase II: feeding by use of toilet/urinal). As the first peak appeared the feeding by yellow water was reduced, which led a decrease of the nitrite. During second and third peak no changes regarding yellow water addition respective restrictions of toilet use were done. Although these concentrations of nitrite have been rather high (possibility of impediment by nitrate), these were reduced by self-regulation of the system itself (stable biological system).

During phase I (feeding by yellow water) of the tests the nitrate nitrogen concentration increased like expected. Just at the beginning of phase II (feeding by toilet/urinal use) a phase of stagnation was observed. It seems that the bacteria for the ammonium oxidation adapted quicker to the new circumstances than the ones for nitrite oxidation. But after a phase of approximately 100 days the nitrate concentration increased again (quick decrease of the nitrite nitrogen concentration down to values below 40 mg/l). Till the end of the experiments the nitrate nitrogen values increased up to a value of about 1400 mg/l. No problems regarding an inhibition caused by nitrate became obvious up to this level. In the literature [Udert, K. M. et al., 2003a] an inhibition by the product of nitrite oxidisers is described as "usually negligible". During lab scale tests (chapter 6.1) even levels of nitrate concentration of up to 3.4 g $\text{NO}_3\text{-N/l}$ have been reached. So even for higher concentrations (longer use periods of the closed loop system) a biological treatment was proven to be possible.

Concentration of total phosphorous increases during the whole time of plant operation (phases I and II) from 2 to 110 mg/l. But the concentrations are still far below the values of urine (700 to 1700 mg/l, [Wissenschaftliche Tabellen Geigy, 1977]). So a further increase for long term application of the black water loop is to be expected, whereas losses by precipitation in the ureolysis tank (Udert gives values of 30% for this topic [Udert, K. M. et al., 2003a], see chapter 7.3.2) are possible.

During the same time the value of the magnesium concentration increases just very slightly from about 3 mg/l to shortly below 10 mg/l. The value of 3 mg Mg/l at the beginning of the experiments is in the range for drinking water (tanks have been filled with drinking water at beginning of experiments) from the three waterworks connected to the university (3 – 7 mg Mg/l, [Chemisch-physikalische Analyse des Reinwassers 2005 - Grundwasserwerk Neugraben, 2006; Chemisch-physikalische Analyse des Reinwassers 2005 - Grundwasserwerk Süderelbmarsch, 2006; Chemisch-physikalische Analyse des Reinwassers 2005 - Grundwasserwerk Wilhelmsburg, 2006]). The concentration of magnesium (50 – 170 mg/l, [Wissenschaftliche Tabellen Geigy, 1977]) in urine is about ten times lower than the concentrations of phosphorous. Compared to a maximum value of 110 mg/l of phosphorous a value of at maximum 10 mg/l magnesium is just slightly lower than expected. A start value of 3 mg Mg/l plus an increase of approximately 10 to 11 mg Mg/l (1/10 of increase of phosphorous) should result in about 13 – 14 mg Mg/l in total. Reason for the slight difference could be a lower magnesium concentrations

in the inflow or the before already regarding phosphorous mentioned precipitations. These can also affect the values of magnesium, because a typical product of these precipitations is struvite [Udert, K. M. et al., 2003a]. Struvite (also called magnesium ammonium phosphate) contains phosphorous as well as magnesium.

During the whole phase of the experiment the odour of the black water was successfully removed by the biological treatment.

An advantage of membrane bioreactors compared to normal biological treatment steps is a higher rate of removal for some pharmaceuticals [Klopp, R., 2005]. The pore sizes of ultrafiltration membranes are too big to remove these compounds by the simple sieving effect, but the higher solid retention time of plants with membrane seem to improve the degradation of some of these micro pollutants [Organic Pollutants in the Water Cycle - Properties, Occurrence Analysis and Environment, 2006; Back, E. et al., 2005; Clara, M. et al., 2005]. The same effect can be expected for the black water loop, but for the pilot plant no analyses regarding this issue have been carried out, because no representative mixture of pharmaceuticals can be expected for the inflow (small group of users). These investigations are a more suitable approach for full-scale implementations with high inflow concentrations like in a hospital.

7.6 Decolourisation and Disinfection

In order to achieve appropriate water quality decolourisation and disinfection need to be reached. These purification steps were mainly performed by UV-C radiation and ozone treatment respectively. First step of disinfection and also of decolourisation (change of colour from dark brown to light yellow) was performed by the membrane filtration prior to this treatment step.

It is possible to meet the limitations of the bathing water directive of the EU just by ultrafiltration [Abwasserreinigung mit Membrantechnik, 2003; Back, E. et al., 2005]. Even viruses are removed because they are normally attached to bigger particles, like e.g. bacteria. During longer use of a membrane the efficiency for removal of germs might be slightly reduced [Back, E. et al., 2005]. UV disinfection is effective at inactivating most viruses, spores, and cysts. Some micro organisms can sometimes repair and reverse the destructive effects of UV (photo reactivation or dark repair) [Ultraviolet disinfection, 1999], but during re-grow of micro organisms pathogenic germs play just a minor relevant role [Oberg, C., 1995].

An additional effect of the treatment by UV-C respective ozone is the degradation of micro pollutants (see chapter 3.4.1). Investigations by Tettenborn and Luchterhand regarding this topic [Luchterhand, B., 2006; Tettenborn, F. et al., 2007b] prove that both techniques have an effect on these compounds. For treatment by UV-C radiation energy demands of 2656 – 3176.8 kWh/m³ are necessary for complete degradation of measured micro pollutants (14 pharmaceuticals and 7 endocrine active substances). In the same publications values of 56.6 – 82.5 kWh/m³ (respective 4.04-5.89 g O₃/l) for a complete degradation of the compounds by ozone are given. The demand of energy for the complete removal is up to 50 times higher by UV-C treatment, than by ozone degradation. [Luchterhand, B., 2006; Tettenborn, F. et al., 2007b] Another publication [Escher, B. I. et al., 2006] gives lower amounts of ozone needed for the removal of micro pollutants of just 0.6 – 1.3 g O₃/l. The complete removal of pharmaceuticals in urine is reached prior to (UV-C) or approximately simultaneous with (ozone) the decolourisation [Luchterhand, B., 2006]. Hence, for the complete decolourisation, like it is necessary

for the black water loop system, also a complete degradation of pharmaceutical residues can be expected, if ozonation or UV-C radiation are the applied decolourisation technologies.

7.6.1 Description and Results

For liquid of the black water loop (slightly different to the yellow water of the lab scale tests) a decolourisation by UV-C radiation or ozone is feasible. Because of technical limitations no ozonation at the plant was possible. Batch experiments were carried out to prove applicability of ozone for decolourisation of liquid from the black water loop. During operation of the plant UV-C radiation including light of 185 nm was used for continuous decolourisation.

The first version of the batch system consisted of just one UV reactor (16 W electrical power, low pressure lamp, 5.6 W emitted at 253.7 nm) without prior air intrusion. The decolourisation was insufficient (see figure 7-9). Hence, a second reactor (108 W electrical power, low pressure lamp, 45 W at 253.7 nm) was added subsequently to the already existing one. During lab scale experiments an effect of the flow rate on the decolourisation was found (see chapter 6.3). A possible reason for this might be the intrusion of air into the liquid with subsequent generation of ozone by the UV radiation. To validate, if an addition of air has an effect on this, as second modification an air intrusion passage was placed prior to the UV-reactors.

During phases of low usage of the toilet liquid from the storage is pumped back to the UV batch treatment loop.

Resulting of the lab scale experiments water with a C^* value of about 1.5 or lower was found to be completely colourless (for UV and ozone treatment, see chapter 6.5). A decrease of the colourfulness below this value need to be reached during these tests to succeed in the complete decolourisation.

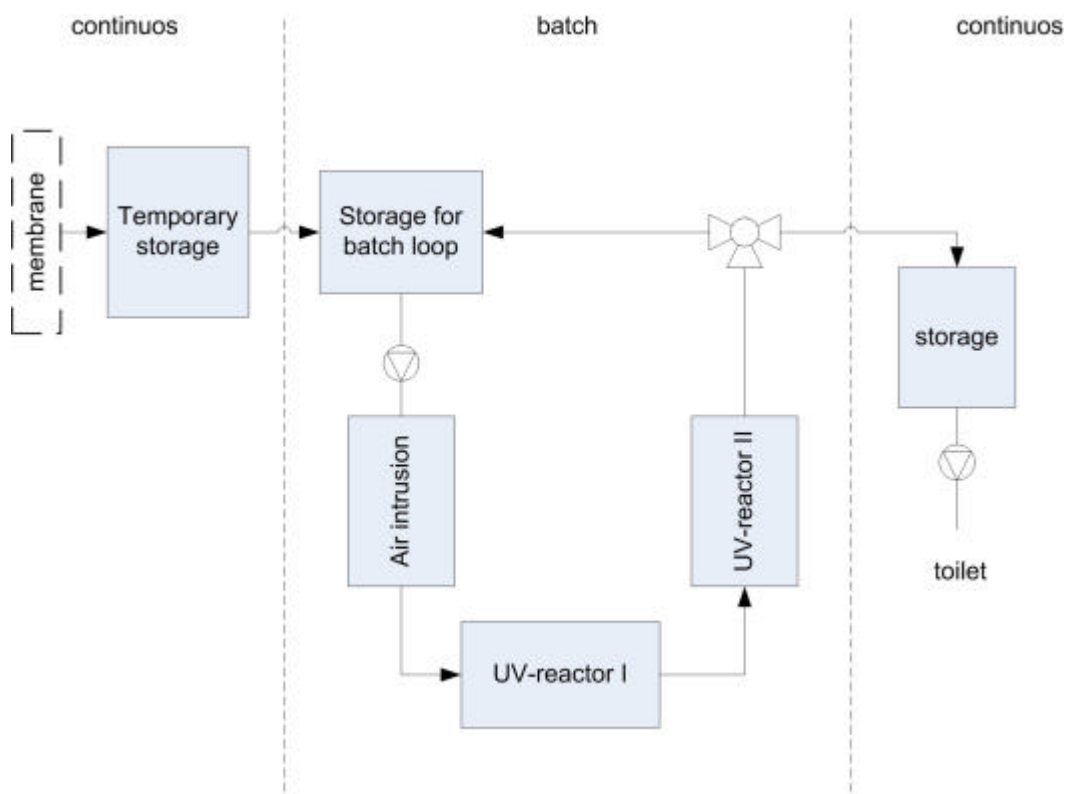

Figure 7-8: System sketch of UV treatment step

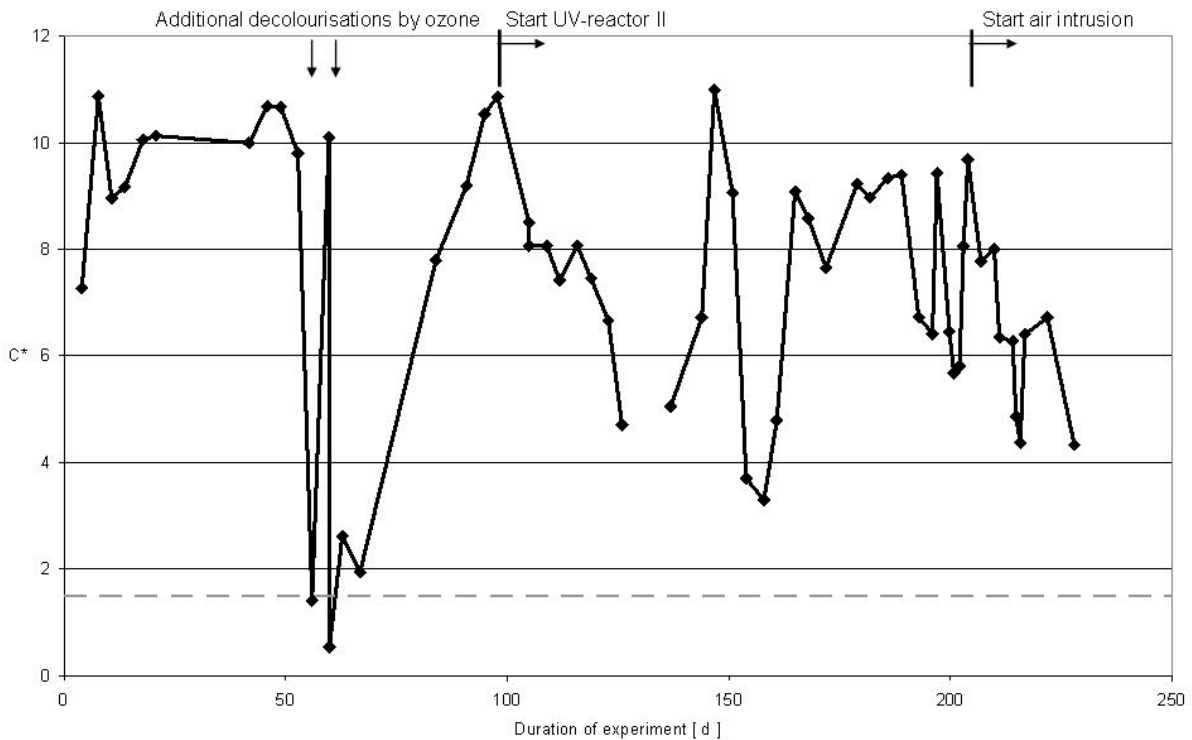

Figure 7-9: C^* values of liquid subsequent to the UV treatment and limit of colourlessness

With UV reactor I a complete decolourisation was not possible. C^* values below 1.5 could only be obtained by two batch experiments with additional ozone treatment (days 55 and 59). Except for these phases the C^* value remained at a level of about 10.

The batch ozonation was carried out for 42 (200 litres from storage tank of black water loop) respective 67 hours (50 l from storage tank of black water loop liquid plus 50 remaining litres from the first test). A simple tank with injection of ozone near the bottom was used. Ozone was generated by a lab ozoniser 301.7 of the Erwin Sander Elektroapparatebau GmbH (max. 250 W electrical power consumption).

Subsequent to the first test the liquid was still slightly coloured. The second test resulted in a completely decolourised liquid. For technical reasons no continuous control of the colourfulness was possible. Additionally the liquid was already pre decolourised by UV-C. After the ozone treatment the liquid was added to the storage tank of the black water loop again.

At the 97th day the additional UV reactor was installed. The C^* values decreased, but except for some peaks the values still remained at a level of about 8 or higher.

The last modification of the decolourisation systems was carried out at the 209th day of the test run. An air intrusion passage was installed prior to the UV reactors. The C^* values decreased to a range between 4 and slightly above 6. Also with this modification a complete decolourisation of the liquid was not reached.

During phases of lower usage of the toilet (e.g. during Christmas vacations, days 126 to 136) liquid from the storage tank was pumped back into the UV decolourisation unit (multiple decolourisation). Hence, the specific energy input (in kWh/m³) for decolourisation increased due to the low inflow. The values for C* and the specific energy input are displayed in figure 7-10.

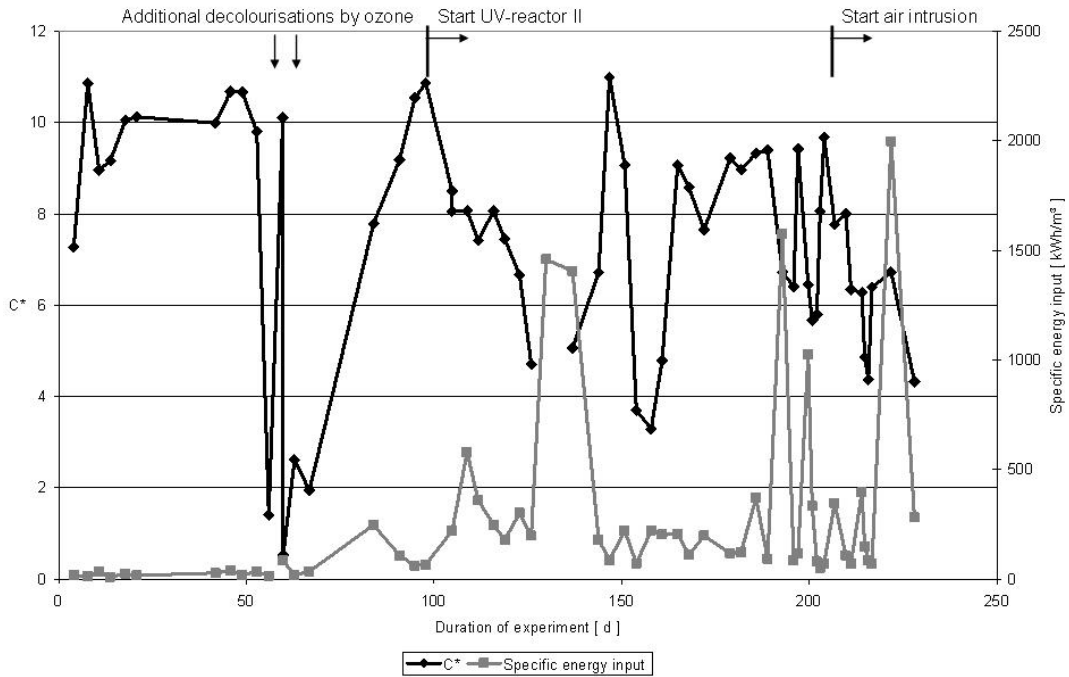

Figure 7-10: C* values and the specific energy input

During phases of high usage of the system or in cases of system stops for maintenance or modifications, sometimes tap water had to be added to the storage tank. All additions during the experiment are shown in figure 7-11.

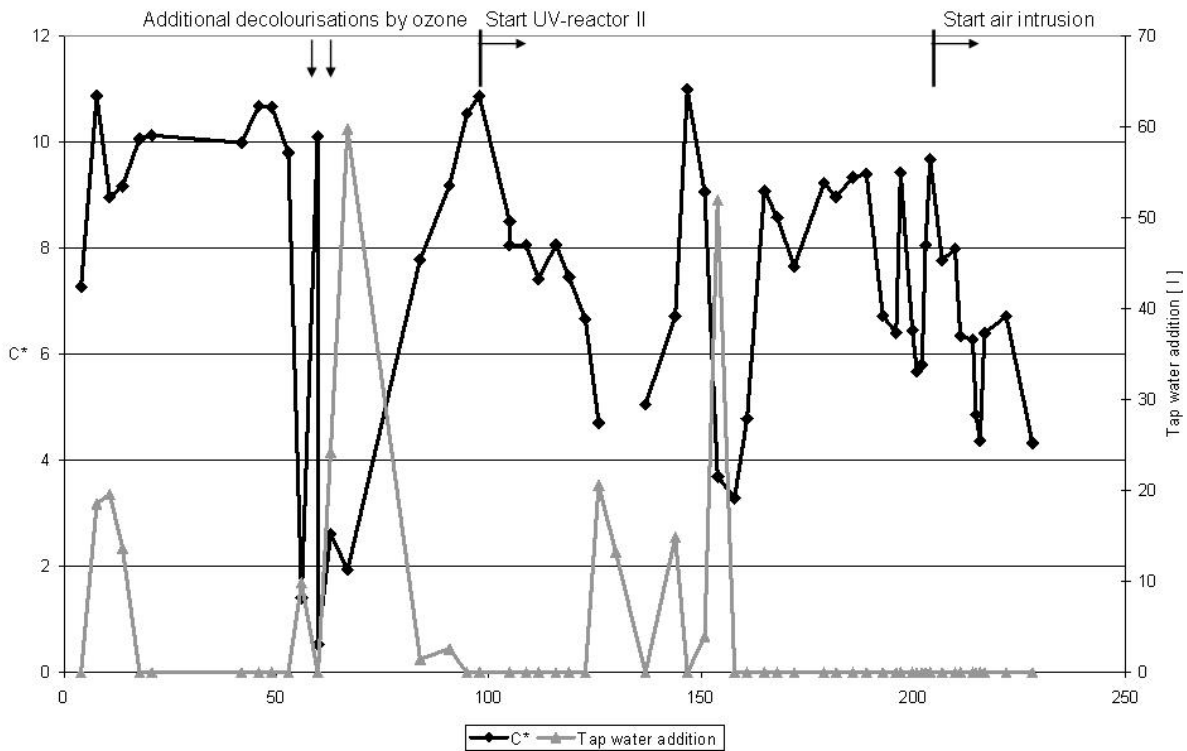

Figure 7-11: C* values and tap water additions

For these investigations 100 ml samples are filtrated via a membrane filter (diameter of 47 mm, pore size of 0.45 µm). Filtration was done by a vacuum filtration system of the company Sartorius AG. Because of the fine pore size, bacteria are kept on the surface of the filter. The cultivation of the bacteria was performed in petri dishes with a selective Chromocult Coliform agar (company Merck, order number 1.10426.0100). The number of cfu was counted subsequent to an incubation time of 24 hours at a temperature of 36°C. The cfu of coliforms and the sub-group of Escherichia coli can be differentiated by their colour (dark blue to violet for Escherichia coli and pink for the remaining coliforms).

Samples for hygienic controls were taken from storage tank (days 221 and 227) respective the intermediate storage prior to the UV-treatment (day 227). For each sample four measurements have been carried out. The average concentrations of Escherichia coli and total coliforms are listed in table 7-2.

Table 7-2: Results of microbiological analysis

Day	Sample taken ...	Average of the four incubations	
		Escherichia coli per 100 ml	Total coliforms per 100 ml
221	subsequent UV treatment	0	44
227	subsequent UV treatment	0	63
227	prior UV treatment	5	43

7.6.2 Interpretation, Conclusions, and Outlook

A complete decolourisation by just UV reactor I was not possible (see figure 7-9). Except some phases, influenced by batch ozonation (days 55 and 59) or tap water additions (days 4 – 13, 55, and 62 - 66, figure 7-11) respectively, the colourfulness C^* remains above a level of 10. The electrical energy input of 16 W (output of 5.6 W at 253.7 nm) is not sufficient for an average inflow of 0.6 litres of toilet wastewater per hour (maximum: 1.8 l/h, minimum: 0.1 l/h).

The addition of UV reactor II to the system led to a reduction of the colourfulness to values between 8 and 10. Phases with significant lower values were caused by low use (high specific energy input, days 111, 129 – 136, 192, and 200, figure 7-10) or by addition of tap water (days 125 – 143 and 150 – 153) respectively. The energy input of both UV reactors of 124 W (output of 50.6 W at 253.7 nm) was not sufficient to decolourise an average inflow of 0.7 litres of toilet wastewater per hour (maximum: 2.5 l/h, minimum: 0.1 l/h).

The addition of an air intrusion passage prior to the UV reactors decolourisation was further improved. The colourfulness decreased to values of 6 and below. Because of the fluctuating usage (specific energy input) during this phase, it can not clearly be stated if this is an effect of the air intrusion. The average inflow for this phase is just slightly lower around a value of 0.6 l/h (maximum: 1.8 l/h, minimum: 0.1 l/h).

Lab scale experiments with higher doses of UV radiation succeeded in decolourisation of the liquid from the black water loop (chapter 6.3.3).

Result of these investigations is that an UV radiation with an output of 50.6 W at 253.7 nm is not sufficient for the decolourisation of 0.7 litres of toilet wastewater per hour (specific energy input of about 206 kWh/m³, C^* of about 8 - 10). Even increases of the specific energy input up to 1573 kWh/m³ (days 188 and 200) led just to reductions of the colourfulness of values around 6. Higher specific energy inputs are necessary for a complete decolourisation (C^* below 1.5, see chapter 6.5). The reduction of the days 122 - 143 down to about 4 was caused by high specific energy input combined with tap water additions and therefore can not be taken into account here.

The selected set-up did not lead to significant depositions on the UV emitter. Found depositions could easily be removed without chemicals.

Relevant for a successful decolourisation is the fact that the liquid of the black water loop remained odourless during treatment by UV respective ozone.

The experiments proved that a complete decolourisation of liquid from the system is possible by ozone. However, as the liquid was already pre decolourised by UV radiation and a continuous measurement of colourfulness was not possible for technical reasons, conclusions regarding the needed energy input for reaching the point of complete decolourisation by ozonation can not be deduced from these experiments.

Tests to check the microbiological pollution of the flush water were carried out (see table 7-2). Relevant guidelines and regulations regarding microbiological loads of water for different re-use purposes are listed in table 7-3. Regulations regarding reuse for flush water are rather limited so far. Currently a working group of the Fachausschuss "Neuartige Sanitärkonzepte" (AG KA-1.2) of the DWA elaborates new guidelines for this topic for Germany, but so far these are not published [Schneider, C., 2007a].

The risks of infections during bathing, or contamination by consumption of raw crops is higher than during use of a toilet. Hence, if the water quality fulfils these standards, also a reuse as flushing water

should be safe from the hygienic point of view. This approach is also assisted by comments found in literature [Brinkmeyer, J. et al., 2005].

The measured concentrations were below the limits of the listed regulations. Therefore it can be concluded that the re-use of this water for toilet flushing does not lead to hygienic dangers.

Table 7-3: Listing of relevant microbiological guidelines and regulations

1: [Richtlinie des Europäischen Parlaments und des Rates über die Qualität der Badegewässer und deren Bewirtschaftung und zur Aufhebung der Richtlinie 76/160/EWG, 2005], 2: [Blumenthal, U. J. et al., 2000a], 3: [DIN 19650: 1999-02, 1999], 4: [Li, Z., 2004], and 5: [fbr H 201 - Grauwasser-Recycling, 2005]

Source	1	2	2	3	2	2	4	5
Field of application	EU directive for bathing water - excellent quality (95 percentile)	World Health Organisation - water for unrestricted irrigation	Revised WHO values - water for unrestricted irrigation	German standard DIN 19650 - water for irrigation of raw eaten plants	Restrictions in different states of the USA - water for unrestricted irrigation	Mexican regulation - water for unrestricted irrigation	Restrictions for in house water reuse in Berlin, Germany	Recommended hygienic parameters for reuse as toilet flush water, Germany
Faecal coliforms respective Escherichia coli [1 / 100 ml]	Inland waters: < 500, costal waters: < 250	< 10 ³	< 10 ³	< 200	< 2.2 · 10 ³	daily mean: < 2,000, monthly mean: < 1,000	< 10 ³	< 10 ³
Total coliforms [1 / 100 ml]							< 10 ⁴	
Intestinal enterococci [1 / 100 ml]	Inland waters: < 200, costal waters: < 100			< 10 ²				
Intestinal nematodes [1 / 1000 ml]		< 1	< 0.1			< 5		
Additional limitations				No salmonellae and parasites			Pseudomonas Aerruginosa < 1 / ml, BOD < 5 mg/l, UV transmission at 254 nm > 60%, O ₂ content > 50%	Pseudomonas Aerruginosa < 1 / ml, BOD ₇ < 5 mg/l, O ₂ content > 50%

The experiments proved that a decolourisation is possible by UV-C as well as by ozone, but should be modified to reduce the necessary energy input. Options to reach this objective are:

- an optimised reactor design
- a combined use of ozone and UV-C radiation
- intermittent ozonation and biological treatment
- nanofiltration (99% removal efficiency for dyes by a membrane of a limit of separation of lees than 500 Dalton [Döpfkens, E., 2004])
- or the use of DIACHEM® electrodes (generation OH radicals directly from the water by high over-voltage).

Additionally the amount of flush water could be varied to check, if a reduction of the flow could save energy in the step of decolourisation.

7.7 Control System and Program

The set-up of the control system of this pilot plant is shown in figure 7-12.

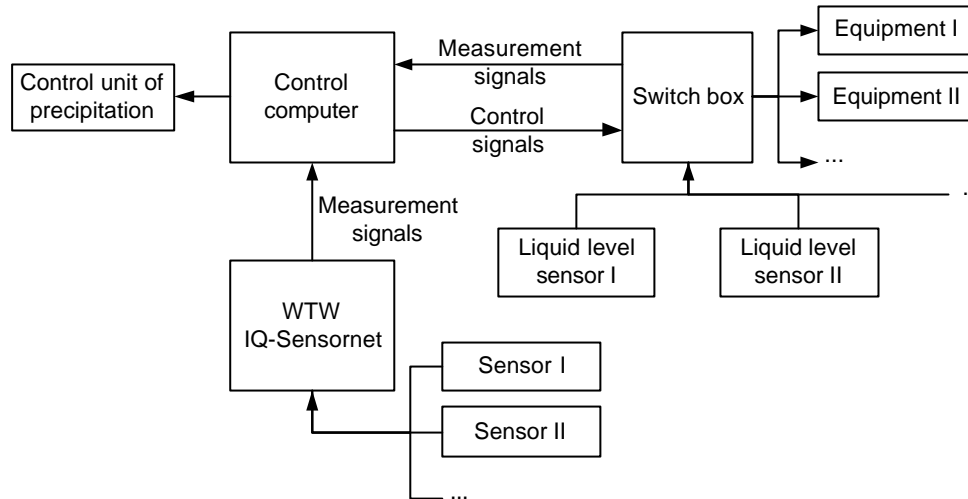

Figure 7-12: Control system of the pilot plant

To keep the system as flexible as possible the control was performed by a computer using TestPoint (version 4.1, Capital Equipment Corporation - CEC) to set up the programming. The switch box was produced to switch all equipments and to evaluate the liquid level sensors. For this measurement floating switches and controls by electrical resistance have been used. The second type of switches caused several technical problems because of short circuit contacts caused by liquid, which entered sensors.

7.8 Acceptance of this System at the AWW Institute

To evaluate the acceptance of the technology of the system inside the AWW Institute an inquiry was carried out. The acceptance inside the institute is influenced by a wide knowledge about the technology. Hence, it is not a representative inquiry, but still can give interesting indications. The inquiry was done by a questionnaire. 23 questionnaires are released and an anonymous return was accomplished. The results discussed in this chapter base upon the 18 (78.3%) returned questionnaires.

The usage of the urinal is quite good (usage just by males). More than 80% use it at least sometimes. Whereas nearly 20% of the people answered that they used it infrequent or never. The usage of the toilet was more common in the group of males (63.6% used it always or often) than in the group of females (0% used it always or often).

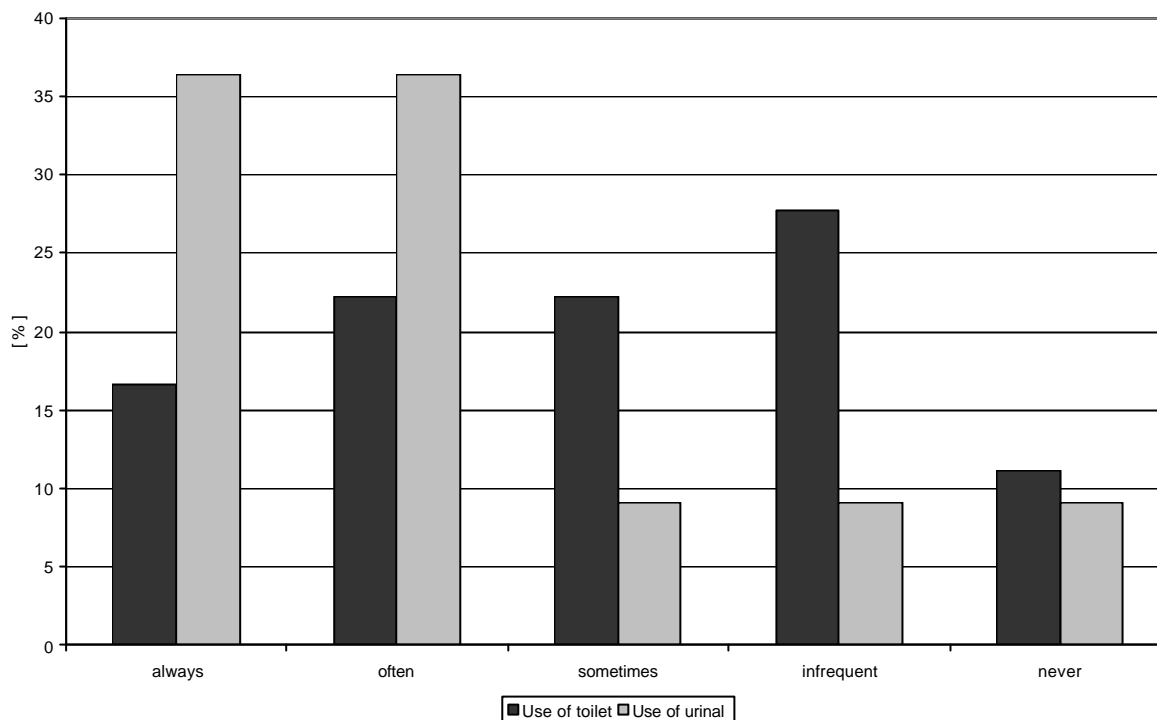

Figure 7-13: Frequency of toilet and urinal use

No one mentioned doubts regarding the technology as reason not to use the toilet (see table 7-4). Main reasons (several selections allowed) not to use the toilet have been the distance (distance between offices and public toilets was much shorter) and the missing privacy (toilets were shown to visitors and practical trainings with students as well as research works have been carried out next to the toilet rooms). The facts that the toilet facilities were placed in an experimental hall and that these facilities were used by males as well as females have been a minor inhibit for acceptance. To see how well the technique works, was for at least nearly 40% of the people a reason to use the toilet.

Table 7-4: Reasons not to use or to use the toilet/urinal

Why did you use the toilet/urinal?	%	What discouraged you to use it?	%
To support the research	77.8	To far away (toilet is not near by the offices)	55.6
Cleaner than the public toilets	22.2	A toilet in the experimental hall is unacceptable	5.6
Internal information (pinboard), newspapers	27.8	Absence of privacy in the experimental hall	38.9
It is my liability as member of the institute	50.0	Shared toilet area for males and females is unacceptable	5.6
Own interest, if the system works well	38.9	Hygienic doubts because of the loop system	0.0
		The yellow colour of the flush liquid acts as deterrently	0.0
		Smell problems	0.0

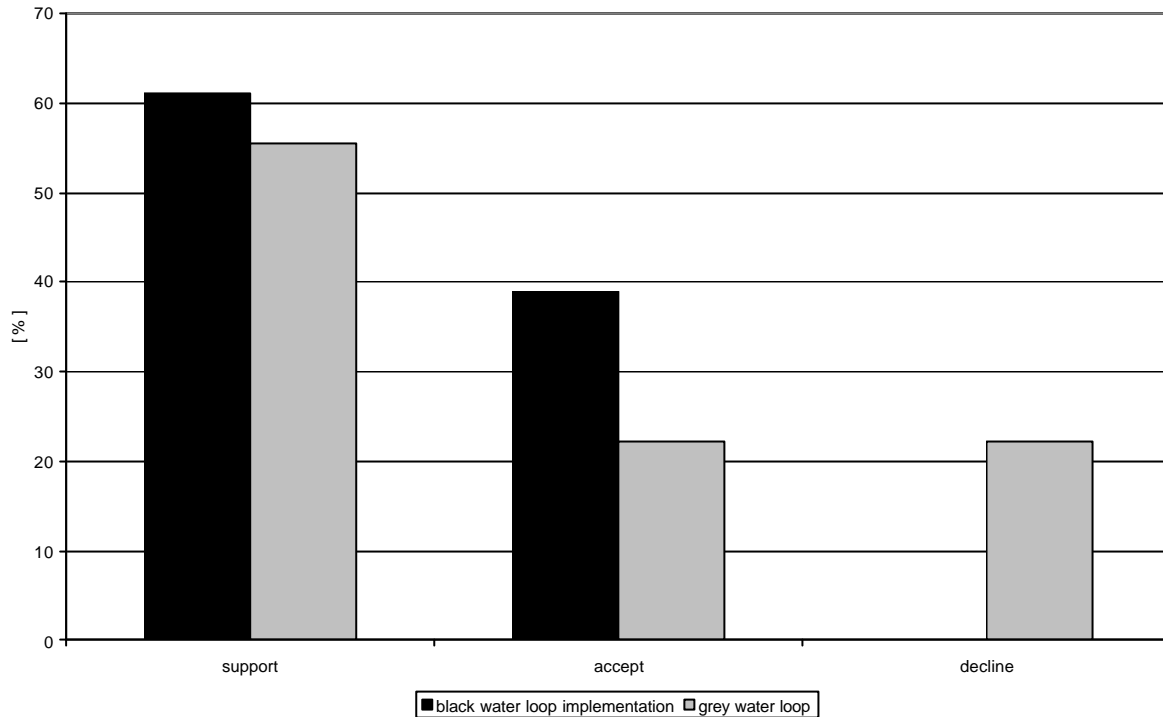

Figure 7-14: Acceptance of a black water respective grey water loop implementation in the own house

To accept the use of a toilet flushed by purified black water at work in a research institute, or to apply this technology even at home, is a different situation. Hence, the acceptance for an implementation at their homes (stable operation and no additional costs presumed) was part of the used questionnaire for the employees of the AWW Institute as well. Everyone would at least accept (38.9%) or even support (61.1%) the implementation of the black water loop. The acceptance for the grey water loop was lower. 22.2% of the respondents would decline the implementation in their houses. Main reason to decline was here, that the people want the security of a passage through the soil for their drinking water. The second reason was that there is no water scarcity in Germany and therefore from their point of view no reason for the implementation of the grey water loop exists. So to use a passage through the ground for the grey water cycle would remove even here all technical doubts. Discussions with people from different countries and of different religions did not lead to cultural or religious obstacles for the implementation of the black water loop. Just the wet anal cleansing in Muslim countries or regions might cause a problem. People might not accept the usage of purified black water for this purpose. But the use of tap water would dramatically increase the additions of liquid to the system and decrease the nutrient concentration in the loop. This needs to be taken into account for design in such regions.

7.9 Overall Interpretation of Tests with the Pilot Plant

In general the test run of the black water loop proved the feasibility of this concept.

Solid separation by a riddle screen with a mesh size of 0.128 mm is a possible option for small implementations. For big plants the application of other screening technologies might be useful.

Resulting of the ureolysis in the first reactor tank the pH increases up to values of about 9.5.

The biological treatment in this set up is mainly done by fixed biomass. The DM of the liquid in the biological treatment tank increased just up to a value of 1.0 g/l. Due to the low inflow the reactor walls have been a sufficient surface for the implementation of this fixed biomass.

Keeping the pH in a range between 7.5 and 8.5 a stable nitrification up to values of 1.4 g/l nitrate nitrogen (low values for nitrite and ammonium) took place. To keep the pH stable an amount of 0.5 litre sodium hydroxide (1 mol/l) per litre urine respective 100 ml potassium hydroxide or 80 ml of sodium hydroxide per each use of the toilet or urinal was necessary (ratio also verified by lab scale titration tests).

The average flux of the membrane was about 0.17 l/m² (no smaller membrane unit available). No blockings became obvious at this low flux level. No chemical cleaning was carried out during the 224 days of operation.

UV reactors with an input of 124 W (output of 50.6 W at 253.7 nm) have not been sufficient to decolourise an average inflow of about 0.7 l/h. The colourfulness C* remains in a range between 4 and 10. Batch tests with ozone as well as lab scale tests with UV-C radiation showed the feasibility of complete decolourisation with both options.

The microbiological loads subsequent to the membrane filtration with respective without additional UV radiation were rather low and fulfilled the limits of the EU bathing water directive as well as other regulations and guidelines for unrestricted irrigation or in-house re-use (see table 7-3). The hygienic safety is ensured even if the UV treatment would not work.

An inquiry at the AWW Institute (just employees of the institute took part, not representative inquiry) showed a high level of acceptance for the system. No one denied the use of the toilet because of the flushing by purified black water. The respondents would all support or at least accept an implementation of a black water loop (stable operation and no additional costs presumed) at their homes. For the grey water loop the acceptance was lower. The people want a passage through the ground for their drinking water.

From the cultural or religious point of view just the wet anal cleansing could be obstructive. The inflow of water from this source needs to be respected if a plant is built in regions where this kind of anal cleansing is practiced.

8 System Variations and Basic Data for Design

This chapter gives an overview of possible options for the further investigation and implementation options for the black water loop system. Therefore modifications and necessary improvements of the existing pilot plant are discussed as well as options and basic design values for real implementations are described. Furthermore risks of application and possible countermeasures are listed in chapter 8.3. Finally advantages of combinations of the black water loop with other technologies are listed and discussed in chapter 8.4.

8.1 Applicability of Existing Plant

During the experiments with the pilot plant some technical problems were found and some ideas for improved research feasibilities came up. Additionally the very high energy demand for the decolourisation leads to the need to test other technical options. In this chapter two general technical set-ups will be described which would ease the research with the pilot plant and would allow to test other options for an improvement of the basic black water loop. The both different set-ups are described in the figures 8-1 and 8-2. All changes described in the following text are listed in the order of the flow path of the liquid through the system.

The riddle screen allows an efficient separation of the faeces. But so far just one mesh size (128 μm) was used. A comparative use of at minimum 512 μm and 1mm mesh size would give an indication on the effect of the water content of separated solids (loss of liquid, effect on possibilities for further treatment and use). As alternative for this technique tests with rottebehaeltern would be possible.

As an optional element for the next generation of black water loop plant an air stripping could be included in the tank for ureolysis. The reduction of the ammonia content in the liquid reduces the amount of nitrogen, which need to be nitrificated in biological treatment. This leads to a reduced aeration demand and a decrease of the needed amounts of base for pH stabilisation (see chapter 7.9). This effect is also supported by the decrease of buffer capacity [Tettenborn, F. et al., 2007a]. Additionally by washing the off gas with sulphuric acid ammonium sulphate is produced. To reach a high efficiency it might be useful to do this stripping in batch operation. In combination with the nanofiltration (version I, see figure 8-1), a stripping subsequent to the addition of retentate might be most effective.

The pH increase caused by ureolysis and the addition of a base and the turbulence inside the tank caused by the (optional) stripping will lead to precipitations. Even this effect will be increased by addition of retentate from the nanofiltration (version I).

To extract the crystals of the precipitation a filter made of geotextile need to be placed subsequent to this combined reactor tank. Valves prior and subsequent to this filter will allow a change of the filter without complete a stop of plant operation.

The tank for the biological treatment should be completely capped. Mechanical foam destruction will securely prevent effervescence. To integrate the precipitation unit in the ureolysis tank leads to a pH regulation by the inflow (pH increased by ureolysis and addition of a base, decrease by optional stripping).

For the decolourisation two possible options might allow to reach this goal with lower energy demand. The option of version I is the already mentioned nanofiltration. Nanofiltration membranes with a limit of

separation at 500 Dalton or lower are already in use for the decolourisation of wastewater of the textile finishing industry [Döpkins, E., 2004]. A batch operation of this filtration allows to increase the concentration of the retentate and to investigate the scaling effect of this on the membrane. Retentate should be added to the precipitation and stripping tank (see descriptions above and figure 8-1). Second option is the decolourisation by a DIACHEM® electrode (generation OH radicals directly from the water by high over-voltage). To get highest flexibility for the investigations, a use in batch operation seems to be useful here as well. Even without prior tests of the germicidal effect of the electrode, the ultrafiltration membrane and an optional UV reactor subsequent to the storage tank (see description later in this chapter) will always ensure sufficient hygienic standards.

The online measurement of the transmissivity of at least one wavelength would allow a simple estimation of the colourfulness. A quicker evaluation of modifications will become possible. According to the spectra found during experiments a useful wavelength for this measurement would be at about 400 nm. For decolourisation with ozone respective UV-C radiation a transmissivity of more than 96% at this wavelength correlates with a complete decolourisation.

To locate an UV reactor subsequent to the storage tank allows investigations regarding microbiological regrowth in this tank without any risk for the user of the toilet. Additionally this reactor could be a second investigated barrier for germs during experiments with the DIACHEM® electrode.

Sometimes malfunctioning of the sensors (measurement of the electrical resistance between metal rods of different lengths) for detection of the liquid level occurred, because of humidity in the sensors. The usage of floating switches was more robust. Hence, a replacement of the sensors by floating switches is recommended.

To get more continuous data and to reduce the work with protocols, the recording of more data of online measurements would be useful. This will also allow investigations regarding automated operation of the plant and give additional data input for modelling and simulation of the black water loop.

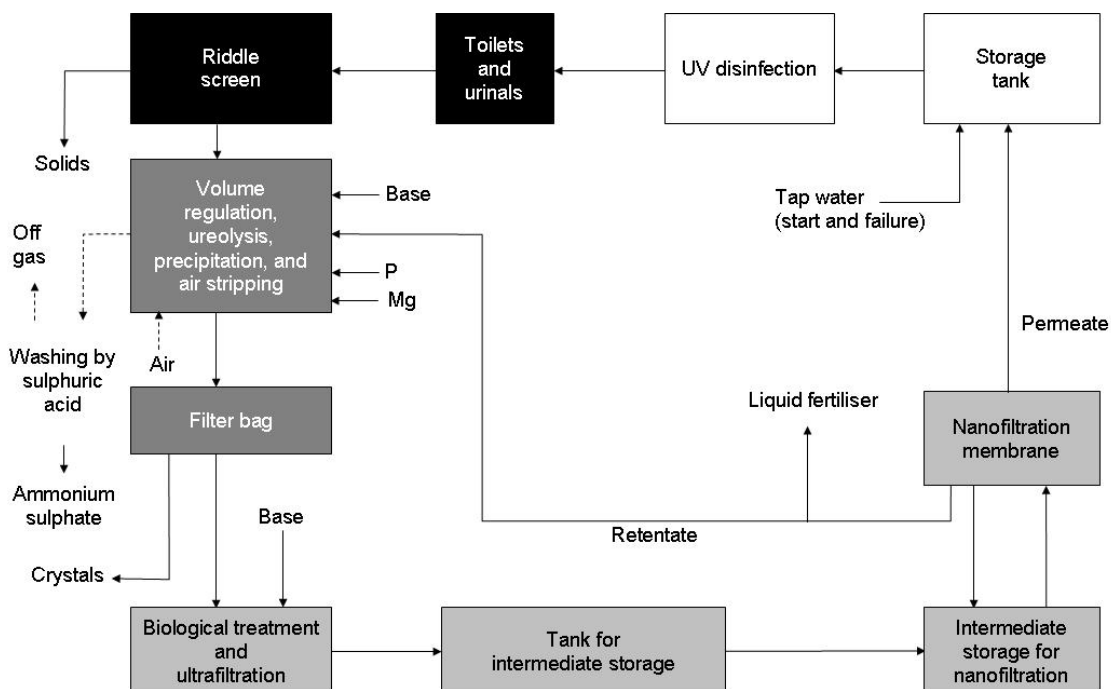

Figure 8-1: System sketch of improved pilot plant with nanofiltration – version 1

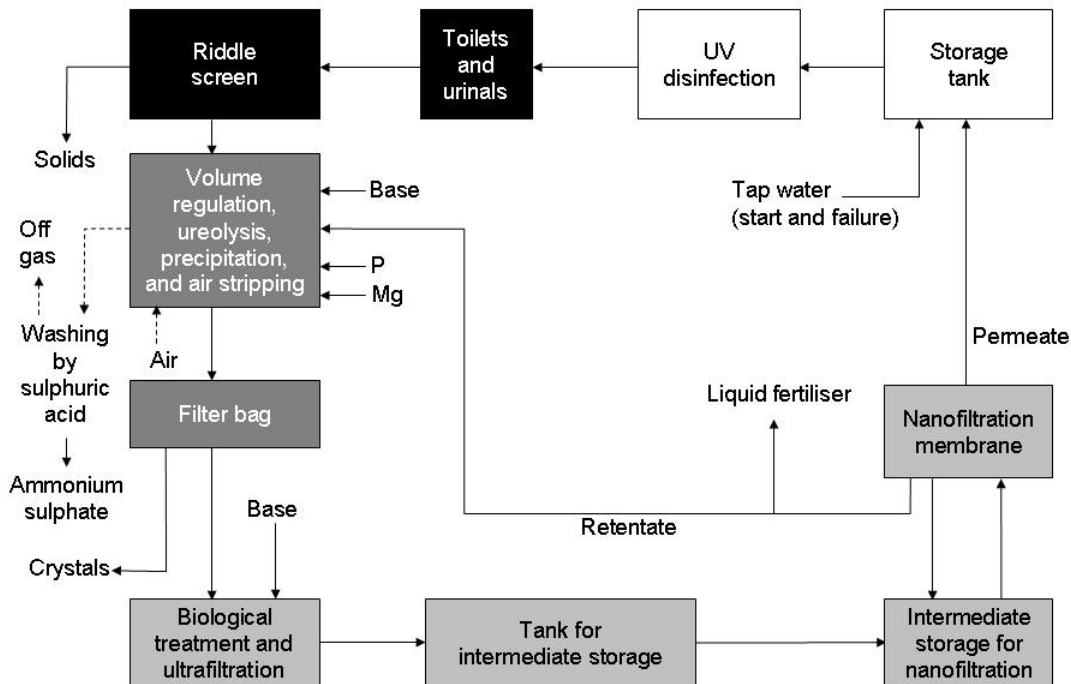

Figure 8-2: System sketch of improved pilot plant with DIACHEM® electrode – version II

A further version would be an alternating treatment by biological degradation (fixed bed system) and ozone cracking. This can be done by pumping between two different tanks (one fixed bed biological treatment, the other ozonation) or by circulation in one tank. The selective reaction of ozone with double bonds allows the application of ozone even prior to complete biological degradation status is reached. The alternating use of ozonation and biological treatment allows the degradation of persistent compounds in just one purification cycle and might be a possibility to reduce the energy demand for decolourisation compared to the so far investigated subsequent decolourisation.

8.2 Possibilities for Improvements and Basic Data for Design of a Full Scale Plant

The discussion of technical equipment of the black water loop in this chapter is done according to the flow path of the liquid in the system.

In Germany average flush water amounts of about 25 to 35 litre per person and day are common [Li, Z., 2004; fbr H 201 - Grauwasser-Recycling, 2005]. Onboard of ships values of 15 – 20 litre per person and day are given in literature [Guttau, S., 2005]. According to [Arbeitsblatt ATV-A 122, 1991] the amount of wastewater in hotels per bed is 1 to 3 times of the common amount of one person. Whereas, the generation of wastewater is much lower in office buildings (amount of one person per 2 to employees). In consideration of these data, amounts of 25 l/p*d for residential buildings, 50 litre per bed and day for hotels, and 12.5 litre per employee and day for office buildings are used for the further calculations.

Prior to the system itself a spill over tank should be installed. In cases of technical break down, power black out, or in cases of unexpected high inflow (parts of) the wastewater can temporary be stored there. If necessary the black water inside the tank can be dispatched by tank lorry. Subsequent to the abolishment of the spill over reason, the black water can be pumped back to the plant inflow. If a connection to a sewer exists, this tank can be replaced by a spill over connection to the sewer.

The dimensioning of this tank should be done according to local circumstances (e.g. number of users, type of building, and amount of water per flush). The volume of the spill over tank should at least be the amount of the black water generation of half a day. According to the local availability of maintenance stuff and tank lorries also bigger volumes might be necessary.

According to literature for membrane filtration a mechanical pre-treatment by sieves with mesh sizes of at 0.5 to 1 mm is recommended [Abwasserreinigung mit Membrantechnik, 2003; Back, E. et al., 2005; Cornel, P. and Krause, S., 2006].

During the experiments a riddle screen was in use for solid separation. The transport of toilet paper sometimes happened too slow and caused higher water contents in the separated solids. Overall the use of a riddle screen is a suitable solution for smaller implementations. Also other experiments with black water at TUHH resulted in a good performance of these kind of sieves [Guttau, S., 2005]. For bigger plant sizes the use of rotating snake sieves is an option. To save energy these sieves could automatically be switched off during phases without inflow.

Technical alternatives for these sieves can be rottesack systems (no energy demand, low investment costs, removal of solids might be problematic), aquatrons (no energy demand, space for one or more of these systems on each floor necessary), or conventional primary sedimentation basins (protection of membrane need to be accounted by design of basin).

The tank for volume regulation serves additionally as ureolysis tank, precipitation unit, and optional as well as container for air stripping (see figures 8-1 and 8-2). To calculate the necessary values for the further calculations volume regulation amount curves for residential, office and hotel buildings have been estimated (see figures 14-6 to 14-8). Resulting from these curves volumes of 8.1 l/inhabitant for residential buildings, 7.4 l/employee for office buildings, and 14.8 l/bed for hotels have been determined.

For the ureolysis carrier material will be added to the tank. To prevent a fast die off of the biomass in this tank a minimum liquid level should always remain in the tank. This volume and the volume of the carrier material need to be added to the total volume of the tank. The ureolysis appears in the drainage pipes and this tank. Experiments showed that just a short time is needed to complete this degradation step [Lohmann, T., 2004].

If the decolourisation is done by nanofiltration (see figure 8-1) additionally volume for the return circuit of the retentate need to be respected. According to the planned retentate rate this will be up to 50% of the tank for intermediate storage for nanofiltration.

Because of the high salt contents (in cases of decolourisation by nanofiltration additionally increased by retentate addition) and the high pH (caused by ureolysis and addition of bases) precipitation will take place here. No additional volume is needed for this.

For the optional air stripping a high liquid level is useful. This needs to be respected for dimensioning. The container also needs to be sealed and the gas outlet needs a mechanical foam destruction.

The biological treatment can be done in an activated sludge tank as well as in a fixed bed system. Due to the low usage the treatment in the pilot plant mainly was performed by fixed biomass. The system worked rather stable also in cases of changing inflow.

In the literature minimum retention times for stable nitrification of more than 4 up to 8 h can be found for membrane bioreactors [Abwasserreinigung mit Membrantechnik, 2003; Cornel, P. and Krause, S., 2006; Guttau, S., 2005]. Results of Udert showed that high salt contents mainly have an effect on the growth rate of the bacteria. Furthermore several other effects can cause an impediment [Udert, K. M. et al., 2003a]. Hence, because of the high salt content and possible accumulation of inhibitory compounds in the loop, a higher retention time should be selected for this system.

A segmentation of the treatment volume in 2 or more tanks can ease maintenance works.

Design as activated sludge tank:

Literature values for the dry matter content of membrane bioreactors for treatment of domestic waste water vary between 8 and 20 g/l [Gutttau, S., 2005; Schleypen, P. and Hruschka, H., 2004]. Higher DM contents allow smaller treatment units but the oxygen transfer into the water becomes impeded in the same time. Hence, values below 12 or at maximum 15 g/l are recommended [Back, E. et al., 2005; Krauth, K. and Gunder, B., 1999]. For DM contents of 10 respective 15 g/l α reduction factors for the oxygen transfer of 0.6 respective 0.5 (compared to pure water) can be used for the design of fine bubble aerations. The oxygen input of the coarse bubble cross flow aeration of the membranes can also be used to cover the demand. According to Back [Back, E. et al., 2005] up to 15% of the oxygen demand can be covered by the cross flow aeration. α values of 0.2 for a DM of 10 g/l and 0.17 for 15 g/l can be used here [Seyfried, A., 2002]. Further values for other DM contents can be found in [Abwasserreinigung mit Membrantechnik, 2003; Krauth, K. and Gunder, B., 1999].

The design values for the aeration can be calculated by the following formulae. For a calculations without denitrification and peak factors for BOD and TKN of $f_{BOD} = f_{TKN} = 1.0$ (equalisation in the ureolysis tank) the formulae 5-27 and 5-28 of [Arbeitsblatt ATV-DVWK-A 131, 2000] can be simplified to:

$$\text{Required } a * OC = \frac{c_s}{c_s - c_x} * \left[\frac{OV_{d,BOD} + OV_{d,TKN}}{24} \right] \text{ in [kg O}_2\text{/h]}$$

The value for $OV_{d,BOD}$ can be calculated by formula 5-24 of [Arbeitsblatt ATV-DVWK-A 131, 2000].

$$OV_{d,BOD} = B_{d,BOD} * 0.56 + \frac{0.15 * t_{DM} * F_T}{1 + 0.17 * t_{DM} * F_T} \text{ in [kg O}_2\text{/d]}$$

$F_T = 1.072^{T-15}$, formula 5-13 of [Arbeitsblatt ATV-DVWK-A 131, 2000] with temperature T in °C. For a sludge retention time of 25 days (selected according to [Abwasserreinigung mit Membrantechnik, 2003]) and a temperature of 20°C (indoor treatment) $OV_{d,BOD}$ can be set to $1.32 * B_{d,BOD}$ ([Arbeitsblatt ATV-DVWK-A 131, 2000], table 7).

The $OV_{d,TKN}$ can be calculated according to the modified formula 5-25 of [Arbeitsblatt ATV-DVWK-A 131, 2000]:

$$OV_{d,TKN} = 4.3 \frac{kgO_2}{kgTKN}$$

For the oxygen saturation at 20°C and at a normal air pressure a value of 9.1 mg/l [Sauerstoffsatigung (Umwelt), 2007] can be used. For the oxygen content in the activated sludge tank a value of 2 mg/l is recommended in [Arbeitsblatt ATV-DVWK-A 131, 2000]. For an average BOD_5 of 13 kg per person and year [Lange, J. and Otterpohl, R., 2000] and a daily nitrogen output per person of 11.5 g (urine) + 1.8 g (faeces) [Wissenschaftliche Tabellen Geigy, 1977] this results to an oxygen demand of 5.56 g O_2 /(h*p). According to [Arbeitsblatt ATV-A 122, 1991] the value can be reduced by 50% for calculations of office buildings, because these are just in use for approximately 8 to 10 hours (even reductions of up to 2/3 can be useful for this kind of implementations). Double of the BOD and nitrogen inflows for hotels (like used for the volume calculation) are not expected, because therefore also the amount of alimentation input would need to be doubled. Hence, in the further calculations for hotels and residential buildings the same values will be used.

Design as fixed bed system:

According to [Bever, J. et al., 2002] formulae 2 to 4 the necessary surface for degradation of carbonaceous compound and nitrification of ammonium in an fixed bed system is

$$A = A_C + A_N = \frac{B_{d,BOD} * 1,000}{B_{A,BOD}} + \frac{B_{d,TKN} * 1,000}{B_{A,TKN}} \text{ in m}^2. \text{ For a purification with nitrification } B_{A,BOD}$$

should be selected as $\leq 12 \text{ g}/(\text{m}^2 \cdot \text{d})$ and for $B_{A,TKN}$ a value of $\leq 1.75 \text{ g}/(\text{m}^2 \cdot \text{d})$ is recommended. With an average BOD_5 of 13 kg per person and year [Lange, J. and Otterpohl, R., 2000] and a common daily nitrogen output per person of 13.3 g [Wissenschaftliche Tabellen Geigy, 1977] this results in a necessary surface of at minimum 10.6 m²/p for residential buildings. For hotels this leads to 10.6 m²/bed and 5.3 m²/employee for office buildings (half of daily amount in the office). The carbon and nitrogen removal by the sieving of the solids is unaccounted in this calculation. The removal rate of the sieves depends on the sieve itself and length as well as design of the black water drainage ducts. The above calculated values can be reduced according to this removal rate.

Even for the fixed bed system a separation into several tanks would ease the maintenance of the system.

For the calculation of the air intrusion two different prerequisites need to be fulfilled. The first one is a minimum gas flow at least 5 to 10 m/h through the reactor ($v = Q_{\text{air}}/A_{\text{footprint, fixed bed}}$ according to formula 1 of [Bever, J. et al., 2002]). The second prerequisite accounted the oxygen demand for the degradation of the carbonaceous compound as well as for the nitrification of the ammonium inflow.

The higher value is relevant for the design of the system. The oxygen demand $a * OC$ can be calculated according to the formula introduced above for the activated sludge system.

For the prerequisites, that no ammonium will be in the outlet of the biological treatment unit and a negligence of the nitrogen removal by sludge extraction, the $OV_{d,BOD}$ and the $OV_{d,TKN}$ can be calculated as follows:

$$OV_{BOD} = 1.30 \frac{\text{kg}O_2}{\text{kg}BOD} \quad \text{modified according to formula 5 of [Bever, J. et al., 2002]}$$

$$OV_N = 4.3 \frac{\text{kg}O_2}{\text{kg}TKN} \quad \text{modified according to formula 6 of [Bever, J. et al., 2002]}$$

For the oxygen saturation c_s a value of 9.1 mg/l [Sauerstoffsättigung (Umwelt), 2007] for pure water at 20° and normal pressure (in house operation) will be used for calculations. The oxygen content c_x is set to 3.0 mg/l (according to [Bever, J. et al., 2002]). For the above mentioned inflow of BOD and nitrogen per person and day, this results to an oxygen demand of 6.43 g O₂/(h*p). See paragraphs on activated sludge system for information on application on the different building types.

The excess sludge generation was extremely low during the experiments with the pilot plant. No sludge needed to be extracted. In general the amount of excess sludge from a membrane bioreactor can be calculated according to [Arbeitsblatt ATV-DVWK-A 131, 2000] formula 5-12.

At the gas outlet of the biological treatment unit a mechanical device for foam destruction need to be installed.

The calculation of the necessary membrane surface needs to be done according to the data from the manufacturers. Typical values for the flux through submerged membranes vary between 5.2 and 35 l/m²*h [Guttau, S., 2005]. External cross-flow membranes can reach flux values of up to 120 l/m²*h [Cornel, P. and Krause, S., 2006]. This flux can be influenced by the temperature. In [Abwasserreinigung mit Membrantechnik, 2003] an increase of the flux of about 15% for a temperature

change from 8°C to 10°C is described. For the calculation of the necessary membrane surface reductions of the flow by back washing or breaks in the filtration process to reduce the membrane blocking need to be respected.

For the permeability the values range approximately between 100 and 200 l/(m²*h*bar) [Abwasserreinigung mit Membrantechnik, 2003].

For estimations of the necessary footprint area of the membranes values from [Back, E. et al., 2005] of 70 to 165 m² of membrane surface per m² of footprint can be used.

Decolourisation can be carried out by radiation with UV-C light or ozonation (see chapters 6.3 respective 7.6). According to literature [Döpkins, E., 2004; Kötze, T., 2004] a further possibility might be the use of nanofiltration membranes.

Resulting from the lab scale experiments for decolourisation by UV-C demands of electrical power of between 24.3 and 53.8 kWh/m³ and per percent of urine content of the liquid can be used as benchmark for the design.

The use of ozone for decolourisation is much more efficient compared to an application of UV-C. But the energy demands of 4.1 to 6.6 kWh per m³ and percent of urine content are still high. Useful information for the design of ozone reactors can be found in [Gulyas, H., 2003].

For both techniques a secure disinfection and a complete degradation of micro pollutants is to be expected [Escher, B. I. et al., 2006; Luchterhand, B., 2006], if reactors design is adequate.

To control the decolourisation a measurement of the transmissivity at e.g. about 400 nm would be useful (see chapter 8.1).

The third possibility of decolourisation by nanofiltration was not tested during the experiments of this dissertation, but according to the literature [Döpkins, E., 2004] a removal of dyes is possible with a nanofiltration membrane (< 500 Dalton, 99% removal efficiency). Like for the ultrafiltration membrane a calculation of the necessary surface of the nanofiltration membrane need to be done according to the data from the manufacturer. In literature values for the flux of nanofiltration membranes of between 90 and 120 l/m²*h for the filtration of urine at 20 bar are given [Pronk, W. et al., 2006c]. In general the pressure for nanofiltration ranges between 2 and 40 bar [Abwasserreinigung mit Membrantechnik, 2003; Kunz, D., 2005]. An at least partial retention of micro pollutants will occur by using a nanofiltration membrane [Escher, B. I. et al., 2006]. Also this technique acts as a second barrier for germs.

The storage tank for the flush water should not be bigger than the volume needed to serve the toilets for one day. This is a value recommended for grey water reuse systems [fbr H 201 - Grauwasser-Recycling, 2005]. This means a volume of less than 12.5 l per employee for office buildings, less than 25 l per inhabitant for residential buildings, and less than 50 l per bed in hotels.

To save energy the flow should be ensured by a hydraulic gradient wherever possible. In these cases pumps can be replaced by valves. A further reduction of the energy demand can be reached by the usage of toilets with lower amounts of flush water. If the implementation of these more efficient toilets generates additional investment costs, a comparison of the savings and the higher investment costs needs to be done.

8.3 Risks of Application

In this chapter possible risks for the application of the black water loop and the effects and countermeasures are listed. Resulting from the so far done experiments an implementation with nanofiltration (version I of improvements of pilot plant, without stripping option, see chapter 8.1) as decolourisation step seems to be the favourable version. Hence, the risk listing is made for this set-up.

Table 8-1: Possible technical risks resulting from the use of the black water loop and associated countermeasures – part 1

Group of failures	Failure	Risk	Countermeasure/solution
Erroneous piping	Crosslink between tap water and flush water piping	- Contamination of tap water system (consumption)	- Lower pressure in black water loop than in tap water system prevents cross contamination - Salty taste (signal for crosslink), if concentration high - Consumption of large amounts of water may have a negative effect on health (germs, nitrite)
	Use of water from black water loop for other purposes	- Use of purified water from the black water loop for drinking, alimentation, cleaning, or personal hygiene	- Salt taste (signal for erroneous piping) - Water fulfils microbiological limits of EU bathing water directive, no risks in cases of use for personal hygiene
Power breakdown	Infrequent incident	- No electrical power for operation of treatment units	- Use of tap water/buffer tank on the roof - Use of emergency backup generator - If necessary disposal of waste water via sewer or truck
	Frequent incident	- No electrical power for operation of treatment units	- Use of an emergency backup generator
Breakdown of system component	Solid separation - Screen clogged	- No flush water supply by loop system	- Use of tap water - If necessary disposal by sewer or truck
	Biological treatment	- No biological degradation of water content - No elimination of smell - Die off of the biomass	- Use of tap water - If necessary disposal by sewer or truck - Partial die off of the biomass: Limited service of plant, re-growth of biomass appears self regulating - Complete die off: Inoculation with new bacteria needed
	Ultrafiltration membrane - no filtration	- No flush water supply by loop system	- Use of tap water - If necessary disposal by sewer or truck
	Ultrafiltration membrane - disruption of membrane	- Increase of microbiological loads - Solids In the flush water - Loss of sludge from biological treatment	- Second disinfection ensures hygienic safety - Cleaning necessary, bigger solids might cause blockings in valves, no further risks - Main part of biomass is fixed, no relevant loss
	Decolourisation, second disinfection	- Flush water is coloured - No second security regarding germs	- If users do not accept the temporary use of coloured flush water, a manual switch to tap water use is possible, disposal of toilet wastewater by trucks/sewer might become necessary - One barrier against germs is still active, no hygienic risk
	Pressure maintenance system of flush water supply	- No flush water supply by loop system	- Use of tap water

Table 8-2: Possible technical risks resulting from the use of the black water loop and associated countermeasures – part 2

Group of failures	Failure	Risk	Countermeasure/solution
Disposal of contraries via the toilet	Compounds with germicidal effect (e.g. antibiotics, detergents)	- Effect on biological treatment in the system	- Biomass regenerates on its own (service of plant may be limited, tap water use and disposal by sewer or truck may be necessary) - Elimination of biomass, inoculation necessary (limited service of plant temporary tap water use, disposal via sewer or truck)
	Biologically degradable compounds without germicidal effect (e.g. pharmaceuticals without germicidal effect, leftovers of food)	- Additional load for biological degradation	- Degradation by system, no action needed
	Not degradable compounds without germicidal effect (e.g. heavy metals)	- Contamination of products	- Dilution decreases effect, risk of relevant contamination seem to be rather low for infrequent disposal of contraries
Damages of supply pipes of the black water loop	Effect on the building	- The same effect like in common systems	- No system specific solution needed
	Effect on persons - contact with the water	- The same effect like in common systems	- Flush water fulfils limits of the EU bathing water directive, no relevant risks for infections
Damages of disposal lines of the black water system	Effect on the building	- The same effect like in common systems	- No system specific solution needed
	Effect on persons - contact with the water	- The same effect like in common systems	- No system specific solution needed
Erroneous handling of the plant	Improper handling of faeces	- Microbiological contaminations, risk for health	- Training of employees
	Malfunction of treatment unit	- No re-use of toilet wastewater, expenses for disposal by truck or via sewer - Expenses for tap water used for flushing	- Training of employees - Support by trained employees of local support companies - If no sewer connection available, disposal of wastewater by trucks - Supply of toilets by tap water
Erroneous handling of chemicals	Contact with bases or acids	- Burns by bases or acids	- Training of employees - Marks on containers in use for bases and acids

Table 8-3: Possible non technical risks resulting from the use of the black water loop and associated countermeasures

Group of failures	Failure	Risk	Countermeasure/solution
Products of black water loop are not be accepted as fertilizer/ as soil conditioner/as raw material for fertilizer generation	By users	- No selling of products possible - Products need to be disposed	- Use of products need to be investigated prior to the implementation - Disposal of solid products via biological waste disposal (additional cost) - Disposal of liquid products via sewer respective truck (additional cost)
	By law	- No selling of products possible - Products need to be disposed	- Use of products need to be investigated prior to the implementation - Disposal of solid products via biological waste disposal (additional cost) - Disposal of liquid products via sewer respective truck (additional cost)
Acceptance of system	No or not sufficient acceptance of the system by users	- Users deny the use of the toilets because of limited acceptance	- Detailed information for users regarding the technique, advantages of the system, and hygienic security - Descriptions of the environmental advantages of the system

The in the tables discussed supply lines are the pipes for the purified water between the plant and the toilet tank. The drainage lines are the pipes leading the flush water from the toilet to the plant.

8.4 Useful Combinations with other Techniques

The listing of technologies in this chapter should give some ideas for which techniques a combination with the black water loop would be useful or not. It is not possible to select the optimal combination for all kinds of houses or settlements. The best solution always needs to be selected according the detailed circumstances and objectives of the implementation. The advances listed below are described as compared with a black water loop system in combination with a conventional central tap water supply and waste water disposal for the grey water.

As first set of the black water loop will be combined with other decentral techniques for reuse or purification of wastewater.

The combination of the black water loop system with the grey water loop (purification up to drinking water quality) and rain water infiltration results in a wastewater free and nearly water self-sufficient housing. This solution would lead to an extremely low water demand. If low contaminated rain water is added to the grey water reuse system the demand might be reduced to zero. This addition to the grey water loop would reduce the salt concentration in the water and would ease the purification process. All the water is recycled and no connection to a sewer is necessary. A surplus of water in the black water loop (addition of liquid by urine) can be used or sold as liquid fertiliser, if this application is

allowed by law. Otherwise a reuse in industry might be possible. For the grey water loop a surplus of water can result from rain water addition. The surplus of water can be used for groundwater recharge by infiltration.

A combination of the black water loop with a grey water purification (service water quality) and a rainwater infiltration leads to a reduced water demand. If surplus of service water is also infiltrated to the ground, no connection to a sewer is necessary. Like in the first combination an addition of low contaminated rain water to the grey water reuse system might be useful. Like as well mentioned before the use of surplus liquids from the black water loop depend on the legal situation.

To combine the black water loop with a rain water re-use system results in a further reduction of the fresh water demand and decreases the amount of waste water.

A system using the black water loop and a rain water infiltration leads to a further reduction of the amount of wastewater.

Further technical combinations are possible regarding the further treatment and use of the separated organic solids. The possible options for this treatment respective use depend on the technique used for the solid separation. The highest dry matter content can be reached by the use of a rotating spiral sieve. This material could be used in an incineration plant or further treated in a composting unit to allow a later use in agriculture. The use of a riddle screen or a rottesack causes higher water contents. A further treatment in vermicomposting units (production of humus like solids for the use in the agriculture or the garden subsequent to a second disinfecting composting) or in an anaerobic digesters (generation of methane respective electric energy and heat) would be possible. These systems of solid treatment and reuse allow also a combined treatment with biological waste.

The solid fertilizer produced in the black water loop system can directly be used in agriculture (depending on legal situation). The liquid fertilizer can also directly be used in agriculture or it can be further treated with one of the in the following listed techniques.

A first option is the generation of solids by technical evaporation. Approximately 5% of dry solids can be generated in this way [Lindner, B., 2001]. But energy is needed for this treatment. If a solar drying of the liquid is possible this energy can be saved. But for the solar drying the necessary surfaces and a sufficient solar radiation are needed.

A further treatment option is the air or steam stripping. E.g. combined with a subsequent washing by sulphuric acid (H_2SO_4) ammonium sulphate can be produced [Tettenborn, F. et al., 2007a]. The remaining wastewater can be treated either by precipitation (addition of e.g. magnesium oxide), by evaporation [Tettenborn, F. et al., 2007a], or by electro dialysis [Pronk, W. et al., 2006a].

The reduction of the flush water demand by water saving types of toilets can reduce the costs for purification in the black water loop system. But if the more efficient toilets lead to higher investment costs, a cost comparison need to be done to find out if this at the end would lead to savings.

The use of vacuum toilets in combination with the black water loop system was not investigated so far. Experiments might be necessary. Possible savings in the purification process and additional costs for the investment in the vacuum system and for the energy demand of its operation as well as the maintenance costs need to be compared by cost comparison calculation.

The use of separating toilets and waterless urinals would allow a separate use and application of the urine. The black water loop would be changed to a brown water loop system. Considerable savings regarding the energy demand for the purification might be possible in this way, but investigations are necessary to verify this. If the used toilets would allow a 100% separation of the urine, no additions to the system would appear anymore. Hence, tap water additions might be necessary from time to time. The economic benefit needs to be checked by a cost comparison based on the results of the investigations. The use of separating toilets might cause problems regarding acceptance, because of the different design. This needs also to be taken into account for the decision.

Water saving water taps does not have a direct effect on the black water loop. An additional saving of tap water and thereby a reduction of the amount of wastewater is possible. A comparison of the additional costs and the savings might be necessary.

The use of solar panels for the generation of electrical power is an option to cover the energy demand of the black water loop system. But the use of this technique does not have a direct effect on the black water cycle.

The use of heat from solar thermal or geothermal systems can reduce the energy demand for heating of water or curing, but there is no direct link to and therefore no effect on the black water loop.

The combination of a low energy house with the black water cycle again does not have a direct effect on the black water loop. Savings of energy are possible by the low-energy-housing concept.

To save energy the application of heat exchangers in the waste water treatment units could be advantageous as the waste water (especially the grey water fraction) contains remarkably amounts of heat.

9 Cost Comparison Analysis

This cost comparison will allow giving statements on economic benefits of an application of the black water loop under various circumstances. For these investigations several methods of calculation exist. Next to the cost comparison also a cost-benefit-analysis, investigations regarding the resource demand of a system, life cycle assessments or similar calculation would be applicable. The application of the cost comparison is suggested for such calculations in the sector of waste water treatment [Leitlinien zur Durchführung dynamischer Kostenvergleichsrechnungen (KVR-Leitlinien), 1998].

Furthermore the black water loop is not fully investigated up to a marketable product. Hence, just calculations on basis of estimations regarding plant design and energy demand are possible and very detailed methods of calculation seem not be suitable for this state of development.

As location for the buildings Hamburg (Germany) was selected. The chosen city is rather huge town and no major advances for decentral systems (as e.g. extremely long sewers) like in more sparsely populated areas exist here. For the calculations rather buildings of 2,000 users have been selected. Buildings of this size normally just exist in bigger towns.

The systems, which will be compared in this chapter, are described in the introducing subchapter 9.1. Also chapter 9.2 is an introducing chapter, as basic calculations and formula for the further calculations are listed and discussed here. In the chapters 9.3 to 9.5 the detailed cost comparisons for the application in a hotel, in an office building respective in a residential building are described. Thereby the costs are calculated for fixed circumstances in a first comparison. Subsequent the circumstances respective several variables (see chapter 9.2) are varied to check the sensitivity regarding these different factors. Finally conclusions regarding the major results of the calculations are described in chapter 9.6.

9.1 Compared Systems and Initial Values

An overview over the system combinations, which will be investigated during the following analysis, is given in table 9-1. Combinations of the black water loop system with a grey water loop system (drinking water quality) respective a grey water purification system (service water quality) are compared with a conventional central waste water treatment and a combination of the end-of-pipe system with the black water loop.

For these calculations the costs for the production of the fertilizer and compost generated by the black water loop are added to the costs of conventional end-of-pipe system, to reach an equal benefit for all variations. As equal benefits are a basic prerequisite for a cost comparison [Eichhorn, U., et al., 2003].

Table 9-1: Compared systems

Systems	Variations			
Black water treatment	Central end-of-pipe waste water treatment plant (EoP)	Black water loop (BWL)	Black water loop (BWL)	Black water loop (BWL)
Grey water treatment		Grey water loop (GWL)	Grey water purification (GWP)	Central end-of-pipe waste water treatment plant (EoP)
Flush water supply	Central water supply	Black water loop (BWL)	Black water loop (BWL)	Black water loop (BWL)
Drinking water supply		Grey water loop (GWL)	Central water supply	Central water supply
Service water supply			Grey water purification (GWP)	

To ease the overview over the compared systems mainly the in table 9-1 used abbreviations will be used in the following chapters.

The set-up of the calculated black water loop system is shown in figure 9-1 and table 9-2. The grey water treatment set-ups are described in the figures 9-2 and 9-3 respective the tables 9-3 and 9-4.

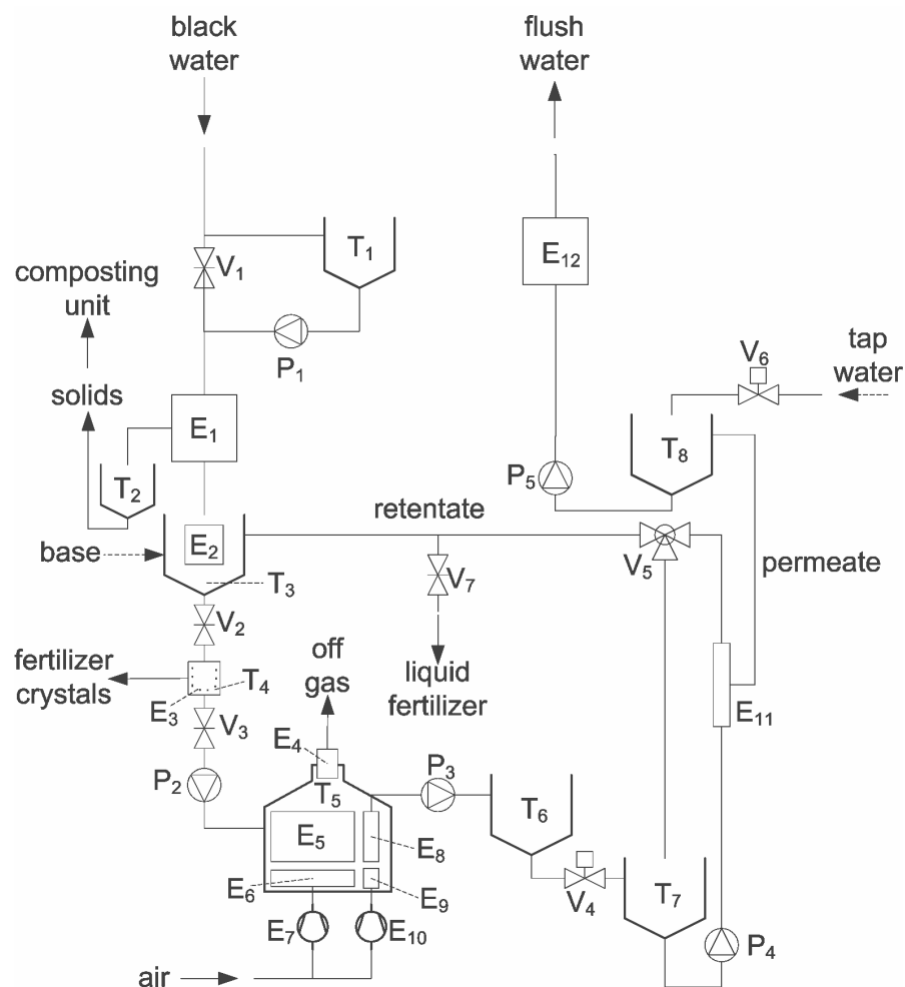

Figure 9-1: System configuration of the black water loop system for cost comparison analysis

Table 9-2: Explanations on abbreviations used in figure 9-1

Abbreviation	Description	Abbreviation	Description
P ₁ - P ₅	Pumps	T ₇	Nanofiltration tank
V ₁	Valve (manual)	T ₈	Storage tank
V ₂	Valve (manual)	E ₁	Sieving unit
V ₃	Valve (manual)	E ₂	Fixed bed ureolysis
V ₄	Valve (automatic)	E ₃	Geotextile filter bag
V ₅	Valve (automatic, 3-way)	E ₄	Mechanical foam destruction
V ₆	Valve (automatic)	E ₅	Fixed bed biological treatment
V ₇	Valve (manual)	E ₆	Fine bubble aeration
T ₁	Spill over tank	E ₇	Compressor of aeration
T ₂	Solid collection	E ₈	Ultrafiltration membrane
T ₃	Ureolysis tank	E ₉	Crossflow aeration
T ₄	Crystal removal tank	E ₁₀	Compressor of crossflow aeration
T ₅	Biological treatment unit	E ₁₁	Nanofiltration membrane
T ₆	Intermediate storage	E ₁₂	Pressure tank

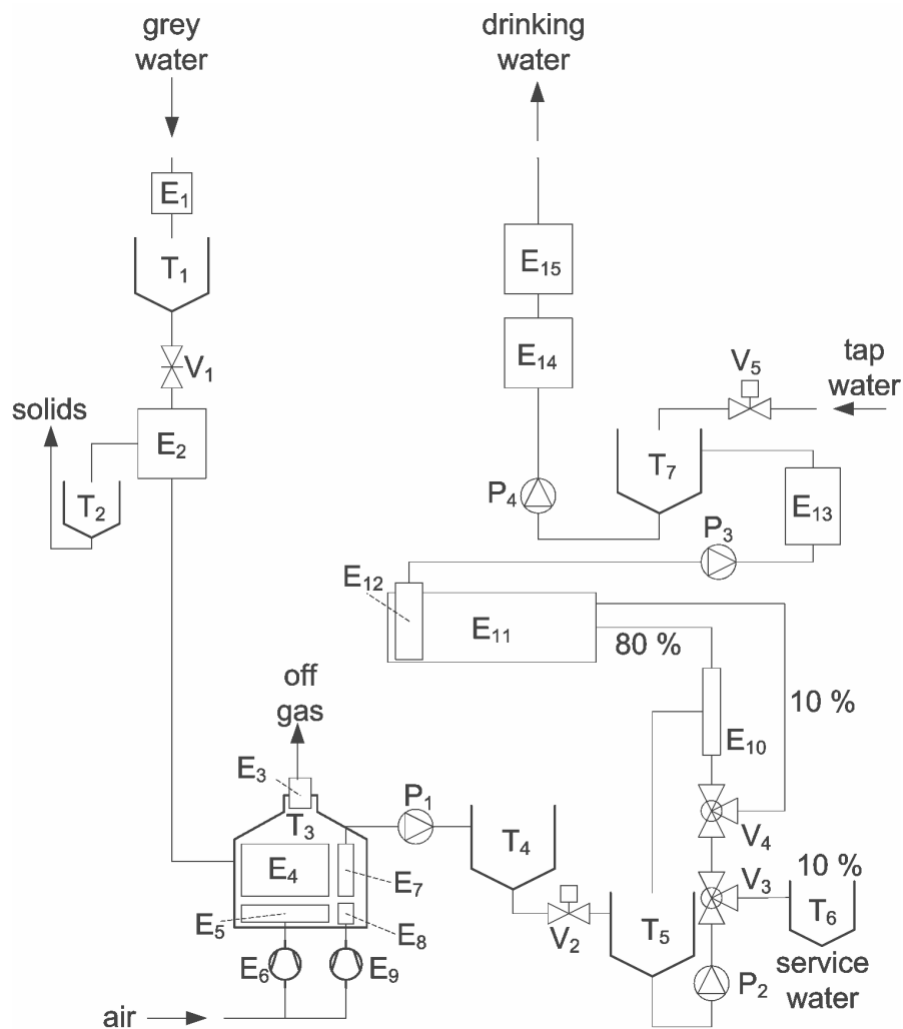

Figure 9-2: System configuration of the grey water loop system for cost comparison analysis

Table 9-3: Explanations on abbreviations used in figure 9-2

Abbreviation	Description	Abbreviation	Description
P ₁ - P ₄	Pumps	E ₂	Sieving unit
V ₁	Valve (manual)	E ₃	Mechanical foam destruction
V ₂	Valve (automatic)	E ₄	Fixed bed biological treatment
V ₃	Valve (automatic, 3-way)	E ₅	Fine bubble aeration
V ₄	Valve (automatic, 3-way)	E ₆	Compressor of aeration
V ₅	Valve (automatic)	E ₇	Ultrafiltration membrane
T ₁	Volume regulation tank	E ₈	Crossflow aeration
T ₂	Solid collection	E ₉	Compressor of crossflow aeration
T ₃	Biological treatment unit	E ₁₀	Reverse osmosis membrane
T ₄	Intermediate storage	E ₁₁	Soil filter with spill over
T ₅	reverse osmosis tank	E ₁₂	Well shaft
T ₆	Storage tank service water	E ₁₃	Sand filter
T ₇	Storage tank	E ₁₄	UV-C reactor
E ₁	Grease trap	E ₁₅	Pressure tank

The ground passage, which is planned for the grey water loop, is a technically not necessary element. The implementation in the system is a result of the acceptance investigation (see chapter 7.8). The acceptance for a reuse of the water for drinking purposes is increased by implementation of a passage through the soil. Furthermore, this passage is an additional barrier against germs and other contaminations. The pore volume can also act as a storage volume and buffer for variations of the water demand without an additional demand of storage space inside the building.

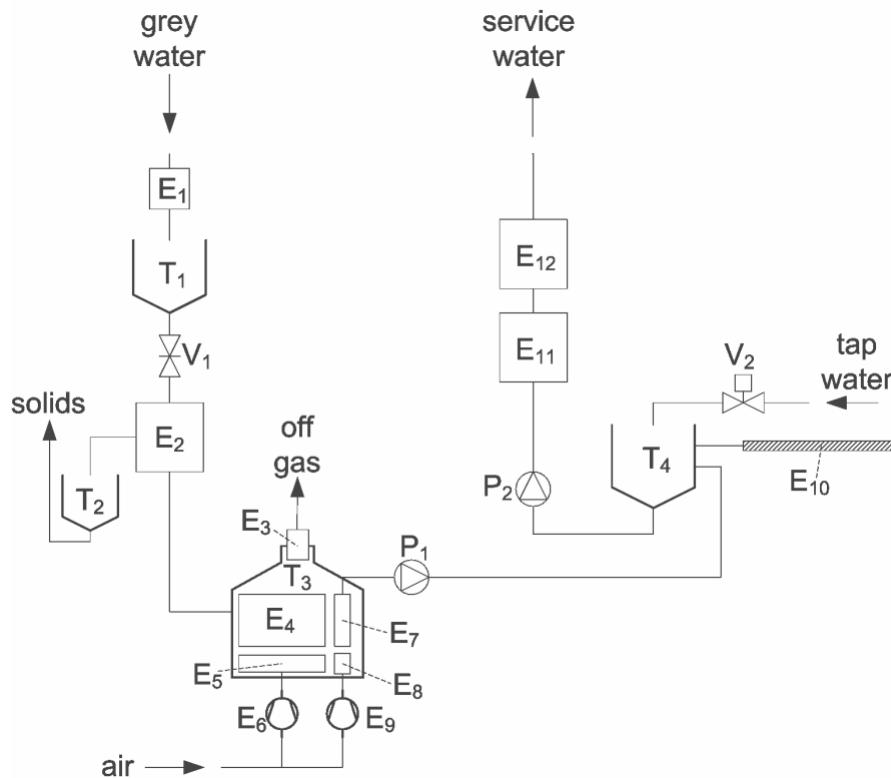

Figure 9-3: System configuration of the grey water purification system for cost comparison analysis

Table 9-4: Explanations on abbreviations used in figure 9-3

Abbreviation	Description	Abbreviation	Description
P ₁ - P ₂	Pumps	E ₃	Mechanical foam destruction
V ₁	Valve (manual)	E ₃	Fixed bed biological treatment
V ₂	Valve (automatic)	E ₄	Fine bubble aeration
T ₁	Volume regulation tank	E ₅	Compressor of aeration
T ₂	Solid collection	E ₆	Ultrafiltration membrane
T ₃	Biological treatment unit	E ₇	Crossflow aeration
T ₄	Storage tank service water	E ₈	Compressor of crossflow aeration
E ₁	Grease trap	E ₉	Soil infiltration
E ₂	Sieving unit	E ₁₀	UV-C reactor
		E ₁₁	Pressure tank

For these calculations a residential building (2,000 inhabitants), an office building (2,000 employees) and a hotel building (2,000 beds) located in Hamburg (Germany) are investigated.

In the grey water systems sieving is used to protect the membranes against hairs and similar pollutions. Just small amounts of solids are expected here. These are reused together with the solids of the black water loop system as well as the excess sludge. For all extracted solids a reuse as compost is assumed, because pollutions (e.g. by heavy metals) are expected to be comparably low (see chapter 3).

For the comparison of the end-of-pipe technique with a decentral treatment in black and grey water loop systems just one additional supply line need to be calculated, because for the grey water loop (drinking water quality) the anyway existing ducts for supply and drainage can be used. But the additional pressure control for the water supply in the grey water loop system will be calculated, because in the conventional supply system a line pressure exists (included in the drinking water fees). Valve number one in all systems is used to interrupt the inflow to the treatment systems for maintenance or in cases of system malfunctions.

In the cases of calculations for the grey water loops system, the generated service water will be used just for irrigation and cleaning works (central service water supply points ? just short additional supply pipe system). For the grey water purification system the service water will additionally be used for washing machines and hand wash sinks.

For the analysis a dynamic method for the cost comparison was used. If costs incur at different dates this will be respected by compounding respective discounting factors [Leitlinien zur Durchführung dynamischer Kostenvergleichsrechnungen (KVR-Leitlinien), 1998].

The costs of the drinking water connection as well as the investments and running costs for the rain water irrigation are the same for all concepts. For this reason these costs do not need to be respected in the calculations.

Necessary surfaces for the implementation of these systems will not be calculated here, because these values depend on the architecture of the buildings. As the tanks can be located in the ground around the buildings, anyhow just rather small areas are expected to be necessary inside the basement of the buildings. For the black water loop system some hints regarding necessary footprint areas are listed in chapter 8.

The costs of the conventional part of the end-of-pipe system will be respected by the waste water fee. For a second way of calculation the specific costs for the different domestic waste water flows are calculated using modified formula of [Dockhorn, T., 2006]. The detailed formulae, the modifications and their application are described in chapter 9.2.

Although the waste water fees in Germany are stable since 2000 [Bellefontaine, K. et al., 2007], an increase is expected, because several topics will cause additional costs in the future (large activities regarding renovation of sewer system, adjustments on the consequences of the demographic changes and new purification steps for the waste water treatment (e.g. removal of germs or micro pollutants)). Hence, variations of these fees are investigated during the sensitivity analysis.

9.2 General Equations

For the calculations amounts and compositions of the grey and black water streams need to be defined. The values are selected according values from the literature and are listed in table 9-5.

Table 9-5: Amounts and compositions of the grey and black water streams

[1]: [fbr H 201 - Grauwasser-Recycling, 2005], [2]: [Arbeitsblatt ATV-A 122, 1991], [3]: [Dockhorn, T., 2006], [4]: [Lange, J. and Otterpohl, R., 2000], [5]: [Wissenschaftliche Tabellen Geigy, 1977]

Grey water						
		Office buildings	Residential buildings	Hotels	References	
Q	[l/p*d]	35	70	140 l/bed	[1], [2]	
COD	[mg/l]	225	535		[1]	
BOD ₅	[mg/l]	111	360		[1]	
P _{total}	[mg/l]	1.5	5.4		[1]	
N _{total}	[mg/l]	10	13		[1]	
K	[mg/l]	9.6			[3]	
Black water						
Q	[l/p*d]	12.5	25	50 l/bed*d	[mg/p*d]	see chapter 8.2
COD	[mg/l]	2850	2850	1425	71250	[2], [4], see chapter 8.2
BOD ₅	[mg/l]	1424	1424	712	35600	[2], [4], see chapter 8.2
P _{total}	[mg/l]	88	88	44	2200	[2], [5], see chapter 8.2
N _{total}	[mg/l]	532	532	266	13300	[2], [5], see chapter 8.2
K	[mg/l]	126	126	63	3150	[2], [5], see chapter 8.2

According to amounts and distribution over the day time the size of the volume regulation tanks can be estimated. For the black water stream the already calculated values from chapter 8.2 are used for this purpose. For the grey water stream the amount curves are displayed in the figures 14-9 to 14-11 in the appendix. Basic values for these curves are calculated in table 14-1. Resulting specific sizes of the volume regulation tanks are listed in the table 14-2.

For the calculation of the end-of-pipe system a separation in two parts was made. The conventional part, including COD and nutrient removal, will be calculated by the waste water fees respective for a second set of calculations by fees according to formulae given by Dockhorn [Dockhorn, T., 2006], which base on the waste water disposal fees for highly polluted water streams (see further below). These formulae are just modified to respect changing energy prices. Additionally to the conventional

treatment the costs of the generation of fertilizer respective compost from the black water stream need to be calculated.

Regarding the fertilizer and compost production the price of the associated amounts of artificial fertilizer respective compost were taken into account (see table 14-3 in the appendix). To be able to respect a varying energy price the below given formula was applied.

$C_{fertilizer} = FP - (ED_{production} \cdot E_i) + (ED_{production} \cdot E_v)$ with $C_{fertilizer}$ = Cost for fertilizer/compost in €/kg substance used for calculations, FP = Fertilizer/compost price from the literature in €/kg, $ED_{production}$ = Energy demand for the fertilizer production in kWh/kg of substance, E_v = Variable Energy price in €/kWh, and E_i = Initial energy price in €/kWh.

According to [Dockhorn, T., 2006] the calculation of the contamination related costs for the conventional end-of-pipe purification including the disposal via the sewers can be calculated by the following formula.

$$G = g + \left[g \cdot \frac{c_{COD} - c_{limit,COD}}{c_{average,COD}} \cdot 0.324 + g \cdot \frac{c_N - c_{limit,N}}{c_{average,N}} \cdot 0.081 + g \cdot \frac{c_P - c_{limit,P}}{c_{average,P}} \cdot 0.027 \right]$$

with G = Cost for purification of this particular waste water in €/m³

g = Fee for disposal of domestic waste water in €/m³

c_i = Concentration of the pollutant (COD, N or P) in mg/l

To get an increase of the fee for streams with higher pollution concentrations than in the average waste water, the formula was modified like this:

$$G = g + \left[g \cdot \frac{c_{COD} - c_{average,COD}}{c_{average,COD}} \cdot 0.324 + g \cdot \frac{c_N - c_{average,N}}{c_{average,N}} \cdot 0.081 + g \cdot \frac{c_P - c_{average,P}}{c_{average,P}} \cdot 0.027 \right]$$

For the average concentrations of domestic waste water Dockhorn gives the here applied values:

$$G = g + \left[g \cdot \frac{c_{COD} - 690}{690} \cdot 0.324 + g \cdot \frac{c_N - 62}{62} \cdot 0.081 + g \cdot \frac{c_P - 8.5}{8.5} \cdot 0.027 \right]$$

This formula is just correct for the by [Dockhorn, T., 2006] calculated energy price of 0.065 €/kWh. For variations of this price the below described modifications are necessary.

The energy demand for the removal of COD, nitrogen and phosphorous is given in table 9-6.

Table 9-6: Energy demand for conventional waste water purification and average concentrations according to [Dockhorn, T., 2006]

Removed substance	Energy demand for removal [kWh/kg removed substance]	Average wastewater content [g/m ³]	Energy demand for removal [kWh/m ³]	Energy costs (for 0.065 €/kWh) [€/m ³]
COD	0.35	690	0.24	0.0157
N	3.07	62	0.19	0.0124
P	13.6	8.5	0.12	0.0075
Total				0.0356

The energy demand for the different removed substances varies greatly and also the concentration in the average waste water differs (relevant for average fee). Hence, changing energy costs must be accounted in specific extends for each substance. To ensure this the following modification will be applied.

$$G = (g - 0.0356) + 0.0356 \cdot \frac{E_v}{E_i} + g \cdot \frac{c_{COD} - 690}{690} \cdot 0.324 + g \cdot \frac{c_N - 62}{62} \cdot 0.081 + g \cdot \frac{c_P - 8.5}{8.5} \cdot 0.027 + \frac{c_{COD} - 690}{1000} \cdot ED_{COD} \cdot (E_v - E_i) + \frac{c_N - 62}{1000} \cdot ED_N \cdot (E_v - E_i) + \frac{c_P - 8.5}{1000} \cdot ED_P \cdot (E_v - E_i)$$

With E_v = Variable Energy price in €/kWh, E_i = Initial energy price in €/kWh, and ED_i = Energy demand for removal of substance i (COD, N, or P) in the waste water treatment plant in kWh/kg substance.

For the drinking water generation an energy demand of 0.54 kWh/m³ [Schuster, M., 2007] is taken into account.

For the precipitation unit of the black water loop additions of chemical substances need to be done. Different substances are possible for this application. Some suitable options and the prices are listed in table 14-5 in the appendix. Objective of these additions is to increase the pH (balancing of the pH reduction during biological treatment) and to enhance the precipitation. To get struvite (slow release fertilizer) as product of this precipitation an addition of magnesium or magnesium hydroxide might be useful. Also the addition of potassium hydroxide can improve the value of the product as potassium is an important plant nutrient. The cheapest ways for a pH regulation is the use of calcium hydroxide. The decision for this selection is mainly influenced by the planned application of the products. For this calculation simply the cheapest version of pH adjustment without addition of magnesium was selected for calculations.

A further relevant aspect for the calculations is the expected duration of the usage of the implemented elements. These durations are selected according to literature values and listed in table 14-4.

Data regarding the sizing, the investment costs, the operating costs, and the energy demand of all calculated elements are given in the tables 14-6 to 14-25. Used element numbering refers to the figures 9-1 to 9-3.

Costs of former years were recalculated and updated for an application in 2007 by using factors available at the homepage of the Statistisches Bundesamt (www.destatis.de).

To be able to evaluate the significance of the values different scenarios as well as variations of relevant values need to be investigated. Calculations regarding the sensitivity of variations of the interest rate, the energy price, the drinking water price, the waste water fee as well as the percentage of surcharge for engineering etc have been carried out. The surplus for “engineering etc.” covers all expenses for pipes and other material needed to connect the equipments as well as the costs for construction, engineering, education of care keepers, revenues on selling the systems, and the support during the start phase of the plant(s). This surplus is calculated as percentage on top of the investment and reinvestment costs of the decentral systems.

The investigated combinations and variations of factors are listed below:

- Initial values for variables combined with conventional system calculated by common waste water fees
- Initial values for variables combined with pollution related waste water fees (according to formula given by Dockhorn)
- Initial values for variables combined with decentral systems equipped with redundancies for all technical elements (conventional system calculated by common fees as well as by formula according to Dockhorn)
- Variation of energy prices with (end-of-pipe costs according to formula given by Dockhorn) and without (end-of-pipe costs according to standard drinking water and waste water fees) direct effect on water fees
- Variation of drinking water fees
- Variation of waste water fees
- Combined variation of drinking water and waste water fees (varied percentage of initial values)
- Combined variation of drinking water fees, waste water fees, and the energy price (varied percentage of initial values)
- Variation of rate of interest
- Variation of percentage for surcharge for engineering, assembling, training for housekeepers, and support for start phase for all decentral options

Table 9-7: Initial values of factors for sensitivity analysis

Price of tap water	1.52 [€/m ³]
Costs for waste water disposal	2.58 [€/m ³]
Cost of energy	0.1476 [€/kWh]
Interest rate	3.0 [%]
Engineering, supervision, construction, ... surcharge	100 [%] of invest/reinvest

9.3 Evaluation of Cost Comparison for the Application in Hotels

For the calculations a hotel of 2000 beds with restaurant but without swimming pool was assumed.

9.3.1 Comparison for Initial Values

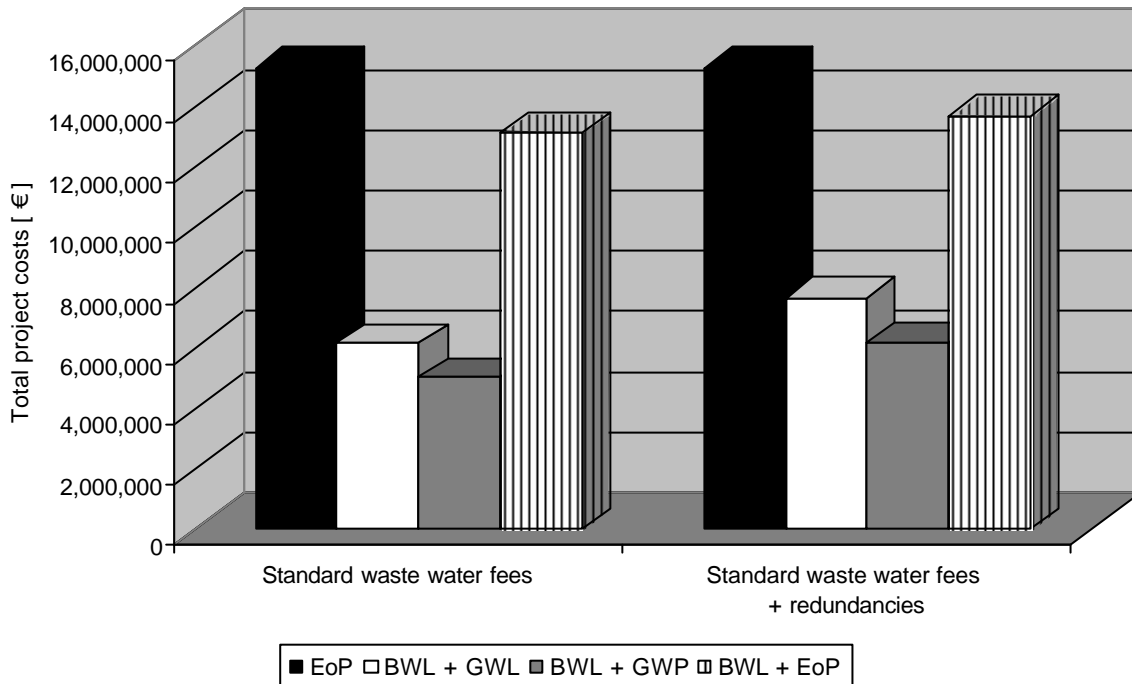

Figure 9-4: Total project costs for a hotel calculated by initial values for variables and standard fees for the conventional system

For the first set of comparisons the end-of-pipe system is calculated by the standard waste water fees (see chapter 9.2). Without additions for redundant technical equipments in the decentral systems the combination of the black water loop and the grey water purification (BWL + GWP) is the cheapest version. It is 3.1 times cheaper than the conventional end-of-pipe (EoP) system, which is the most expensive option for this case.

Also for increased investment and reinvestment costs for redundancies in the decentral systems the combination BWL + GWP remains the cheapest and the EoP system the most expensive set up. The difference between both systems decreases to a factor of 2.5.

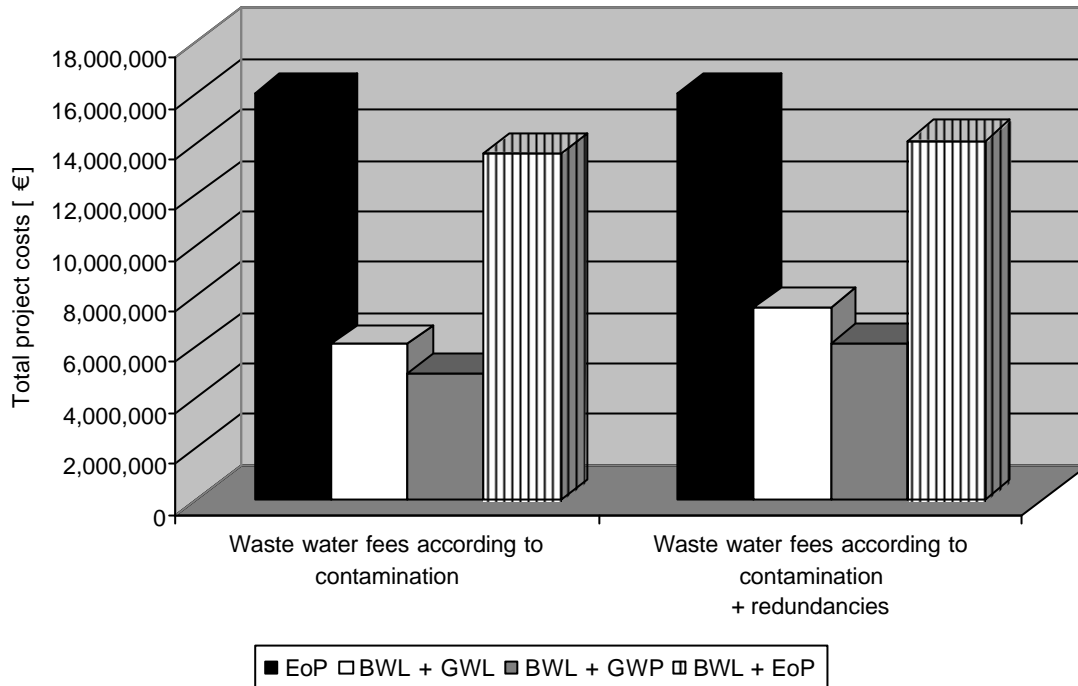

Figure 9-5: Total project costs for a hotel calculated by initial values for variables and waste water fees according to contaminations for the conventional system

Also the calculation of the conventional system (EoP) according to contamination related waste water fees (see chapter 9.2) for both cases results in nearly the same results. BWL + GWP combination is the cheapest and EoP the most expensive system option. Main difference to the calculation by standard waste water fees is that the economic benefits of decentral systems increase slightly. Without redundancies the BWL + GWP combination is now 3.2 times cheaper than the EoP system. With consideration of the redundancies the factor between both systems still is about 2.6.

The detailed values expressed as total project costs as well as annual costs are given in table 14-26 in the appendix.

9.3.2 Sensitivity Investigations Regarding Several Variables

Several variables have been varied for these sensitivity investigations. The first one is the rate of interest. As shown in figure 9-6 for the whole relevant range for the rate of interest (in [Leitlinien zur Durchführung dynamischer Kostenvergleichsrechnungen (KVR-Leitlinien), 1998] values between 2 and 5% are given as relevant) the combination BWL + GWP remains the cheapest and the conventional EoP system the most expensive solution. Just for interest rates of 37% and more (far above relevant level) the EoP system becomes the cheapest option. The detailed intersection points for this variable are listed in table 14-29.

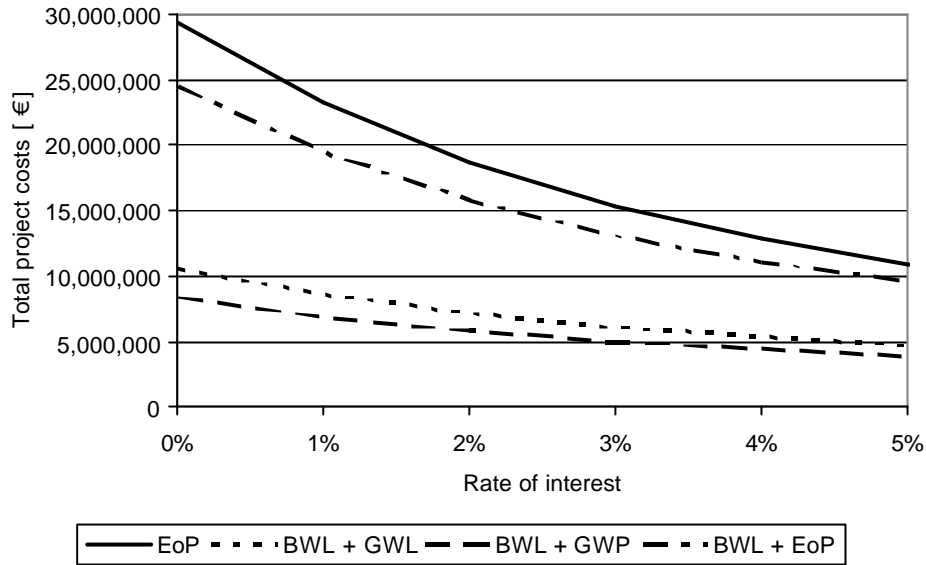

Figure 9-6: Results of sensitivity investigations on varying rates of interest on the application of the systems in a hotel

Because of the different levels of water reuse a varying drinking water prices influences the operation costs of the investigated systems and combinations in different extends. The conventional system is not related to any water reuse and therefore is the system with the highest impact on varying drinking water price. But even for a water fee of 0 €/m³ (0%) the EoP system remains the most expensive option (see figure 9-7). For values above 241% (drinking water fee of 3.66 €/m³) the combinations BWL + GWL becomes the cheapest solution. For lower values (containing the realistic range) the combination of BWL + GWP is the most economic option.

The detailed value for the intersection point of this variable is given in table 14-30.

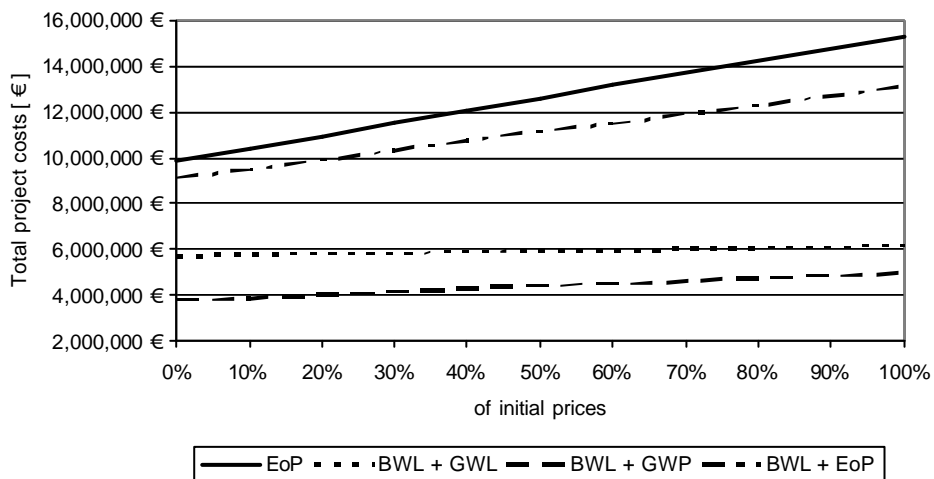

Figure 9-7: Results of sensitivity investigations on varying drinking water fees on the application of the systems in a hotel

As for the decentral systems with black and grey water purification the whole amount of water is purified and if necessary infiltrated in the ground locally, no waste water fees were accounted for the

combinations BWL + GWL and BWL + GWP. Hence, these combinations are not effected by variations of this factor.

Similar to the variation of the drinking water price even a waste water fee of 0 €/m³ (0% in figure 9-8) is not low enough to make the EoP system the cheapest solution. For values below 9.9% (0.26 €/m³) the EoP system becomes cheaper than the combination BWL + EoP. For values below 0.5% (0.01 €/m³) the EoP system becomes also cheaper than the combination of BWL + GWL, but the combination of BWL + GWP remains always the cheapest option. The detailed values for the intersection points of this variable are given in table 14-31.

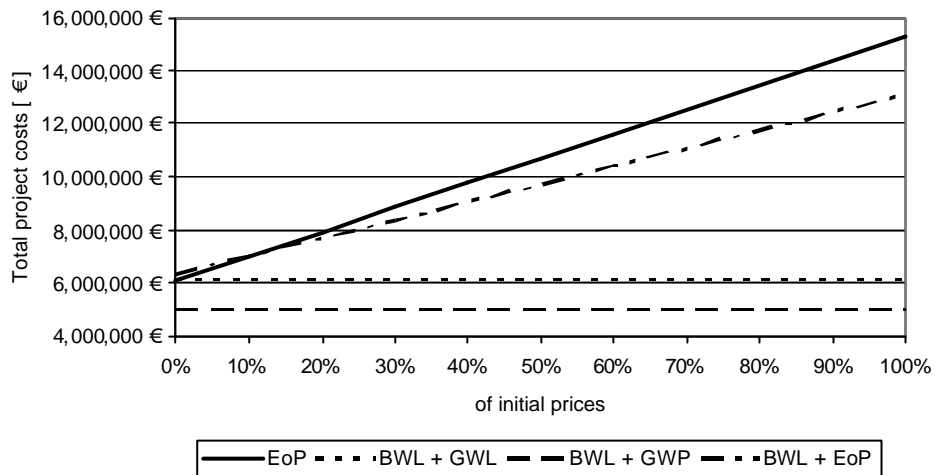

Figure 9-8: Results of sensitivity investigations on varying waste water fees on the application of the systems in a hotel

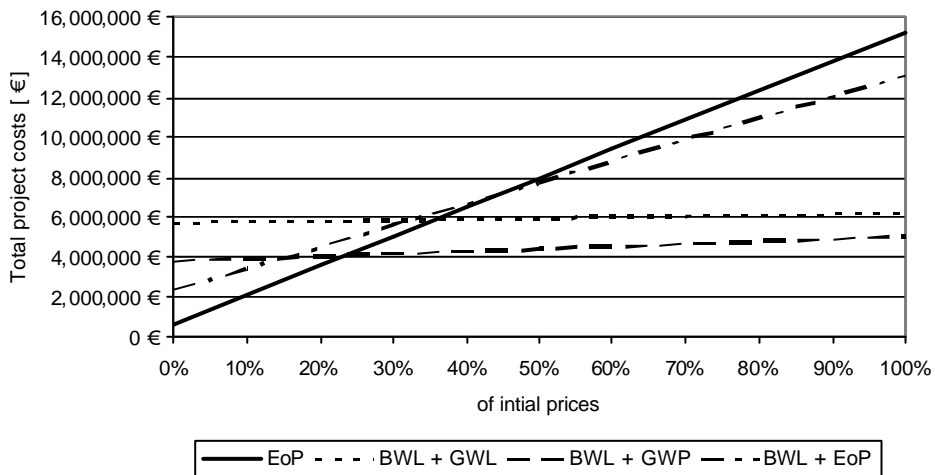

Figure 9-9: Results of sensitivity investigations on varying drinking and waste water fees on the application of the systems in a hotel

The combined variation of the fees for drinking and waste water (same percentage of the initial values for both fees) impacts the different combinations according to their level of water reuse respective the generated amounts of waste water. Hence this variation has just a slight effect on the combination BWL + GWL, but is an important aspect for the costs of the EoP system (see figure 9-9). For values below 23% (0.35 €/m³ drinking water, 0.60 €/m³ waste water) the EoP system is the most economic

solution. For values above this limit and below 241% the combination BWL + GWP is the best economic option. Above 241% the combination BWL + GWL becomes the cheapest alternative. All values of the intersection points of this investigation are listed in table 14-32.

Next to water fees also the energy price is a very important aspect for economic benefits of technical systems. Hence, this was investigated here excluding respective including the effect, which a variation of the energy prices has on the costs for a central waste water treatment plan and a central supply water plant.

The first results show the variation of the energy price without respecting any related effects on other variables. This variation just results in an effect on the EoP system as the changing energy price effects the costs of the fertilizer and compost production.

For values below 29% (0.04 €/kWh) the combination BWL + GWL is the economically most beneficial option. Above this limit and up to 1745% (2.58 €/kWh) the combination of the BWL + GWP is the cheapest solution. Above this level the EoP system becomes the best option regarding economic aspects. The value of 1745% is very high. An increase of the energy price up to this level seems not to be realistic in the near future. Also values below 29% of the current price seem hardly to be possible in Germany. Hence, the combination BWL + GWP is the most economic one for the whole relevant range.

All intersection points of the related graphs are listed in table 14-33.

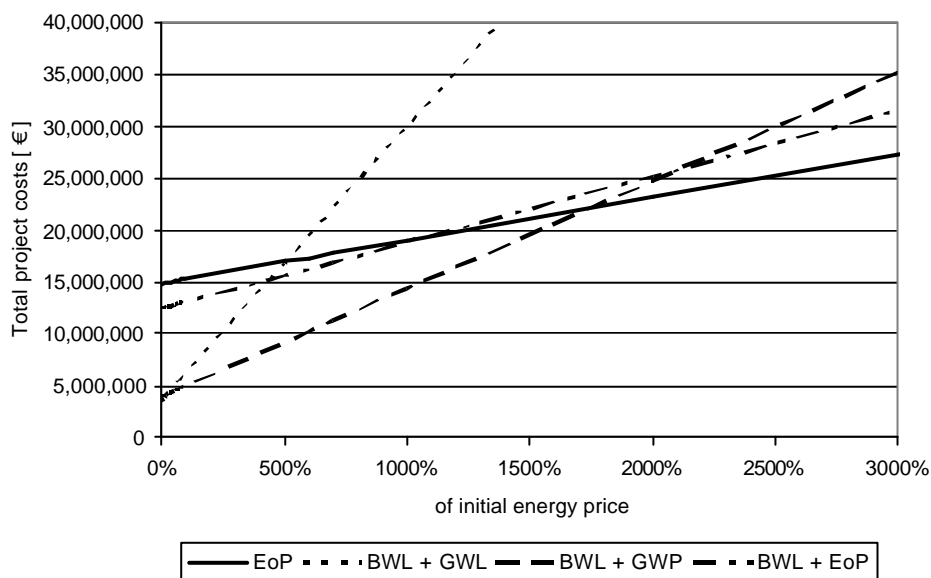

Figure 9-10: Results of sensitivity investigations on varying energy prices and constant water fees on the application of the systems in a hotel

As second way of calculation for a varying energy price is the application of the modified formula according Dockhorn (see chapter 9.2). The waste water fees are calculated respecting the level of contamination. The energy demand of the waste water purification as well as for the supply water generation is respected in these formulas. Hence, an increase in the energy price leads directly to an increase in the waste water and drinking water fees and the other way round.

For the relevant range of percentage the combination BWL + GWP is the cheapest solution (see figure 9-11). Just for values below 28% (drinking water fee: 1.49 €/m³, waste water fee: 2.76 €/m³, energy price: 0.04 €/kWh) the combination BWL + GWL becomes cheaper. A second intersection

point was found at a value of 3163% (drinking water fee: 2.59 €/m³, waste water fee: 4.24 €/m³, energy price: 4.67 €/kWh). Above this limit the EoP system becomes the economically most beneficial option. The intersection points related to this investigation are given in table 14-34.

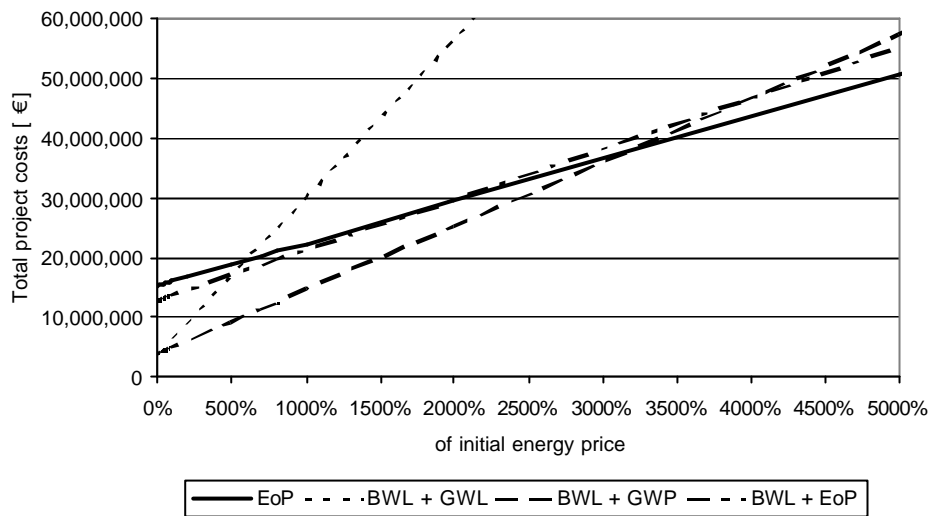

Figure 9-11: Results of sensitivity investigations on varying energy prices respecting the direct effect on the water fees and contamination related waste water fees on the application of the systems in a hotel

The last investigation regarding the energy price is the parallel in- respective decrease of the energy price, the drinking water fee and the waster water fee (percentage of the initial values).

As shown in figure 9-12 just for very low values of less than 19.5% the EoP system is the most economic solution. Above this level the combination of BWL + GWP is the cheapest option. A value of below 19.5% is not to be expected for Germany and therefore has no significance for the selection of the most economic option.

The intersection points for these calculations are listed in table 14-35.

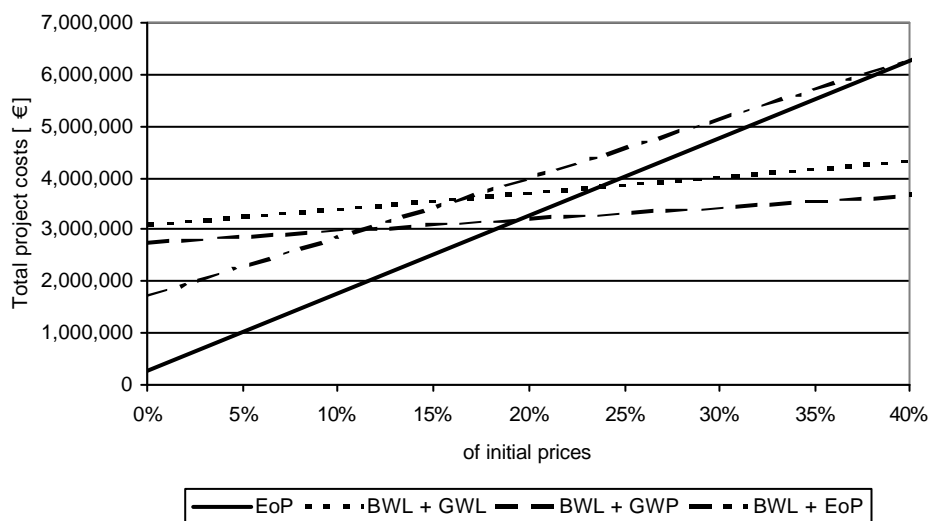

Figure 9-12: Results of sensitivity investigations on varying energy prices and drinking water and waste water fees on the application of the systems in a hotel

Also the surcharge for engineering, assembly etc. was varied during these investigations. This led to the graphs given in figure 9-13. As these values do not affect the EoP system, the values for this solution are constant.

For surcharges of below 994.5% the combination BWL + GWP is the cheapest set up. Above this level the EoP system becomes the cheapest. This level is above the realistic range and it can be stated that also this variable has no significant relevance for the selection of the cheapest option.

The list with all intersection points, related to this variation, is given in table 14-36.

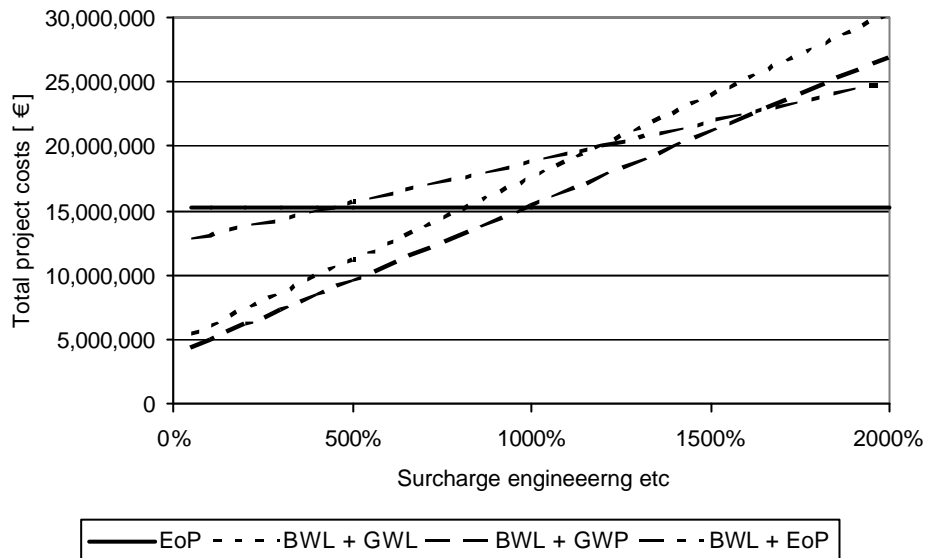

Figure 9-13: Results of sensitivity investigations on varying the surcharge for engineering etc on the application of the systems in a hotel

9.3.3 Results of Comparison for Application in Hotels

The investigations for the initial values showed that for an application in a hotel of this size the EoP system is the most expensive solution for all calculated options (see chapter 9.3.1). The cheapest solution always was the combination of the BWL + GWP.

The results of the investigations for the initial values depend on the selection of these start values. Hence, a check of important variables regarding the sensitivity of the results on changes of these values is an important investigation to check the significance of these initial results. The rate of interest, the drinking water and waste water fees, the energy price, and a surcharge for engineering etc have been varied in different combinations during these tests. For all variations the system combination BWL + GWP was the most beneficial set up, if just the for Germany realistic range of variations is taken into account. Just for some extremely high respective low values also the combination BWL + GWP or the EoP system became the most beneficial options.

9.4 Evaluation of Cost Comparison for the Application in Office Buildings

The calculated office building with space for 2000 employees does not possess canteens or restaurants. It is estimated that the number of visitors is equal to the number of employees working off-site. Furthermore, it is estimated that the amount of black water, which is generated at the office, is half of the daily amount.

9.4.1 Comparison for Initial Values

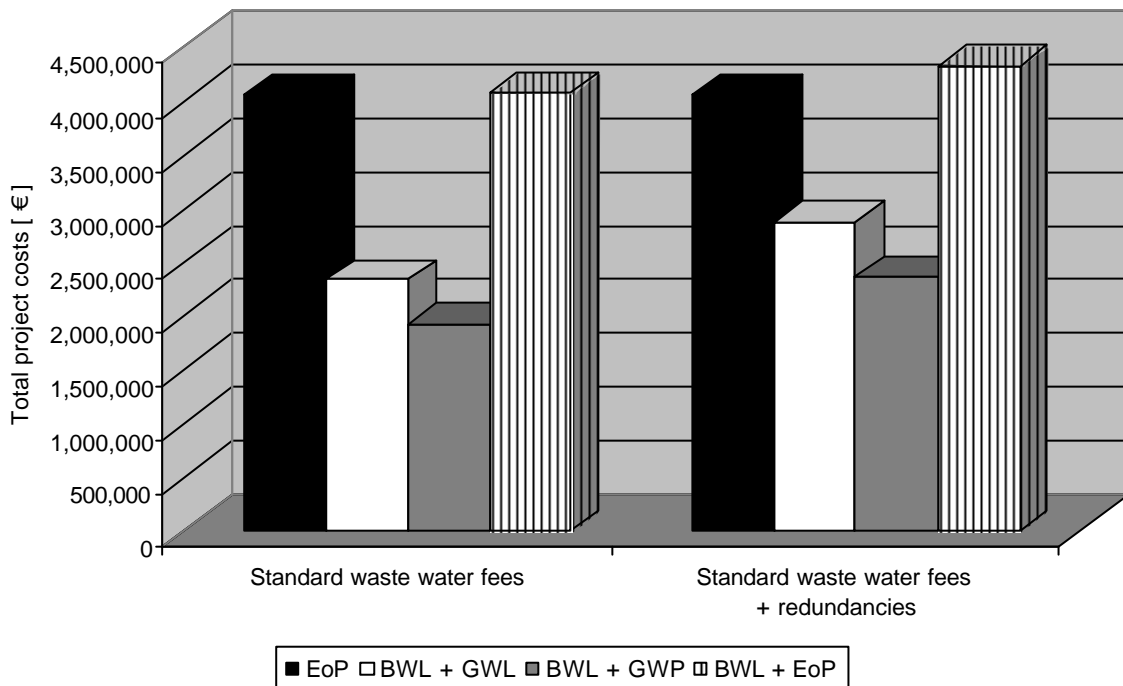

Figure 9-14: Total project costs for an office building calculated by initial values for variables and standard fees for the conventional system

For the calculation with standard waste water fees (see chapter 9.2) the combination BWL + GWP is the cheapest and BWL + EoP the most expensive set up. The consideration of redundancies for all technical elements in the decentral systems leads to the same order of combinations. The combination of BWL + GWP is about 2.1 times cheaper than the EoP system without and about 1.7 times cheaper with consideration of redundancies. There are just slight differences between the costs for the EoP system and the in this case most expensive combination of EoP + BWL (factor of 1.002 without redundancies and 1.06 including redundancies).

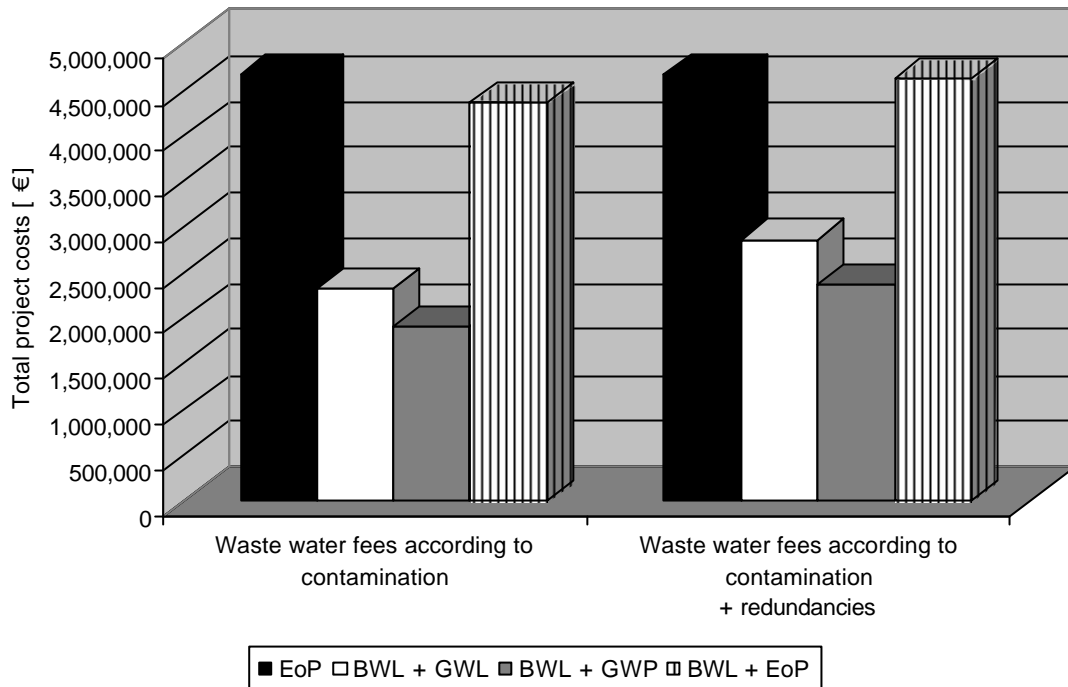

Figure 9-15: Total project costs for an office building calculated by initial values for variables and waste water fees according to contaminations for the conventional system

A calculation of the end-of-pipe system with waste water fees according to the contamination (see chapter 9.2) improves the economic benefits of the combinations with decentral set ups. The EoP system is the most expensive and the combination BWL + GWP cheapest option. Without redundancies the combination BWL + GWP is 2.4 times cheaper than the conventional EoP system. With consideration of the redundancies for the decentral set ups this value decreases to about 2.0.

The detailed values expressed as total project costs as well as annual costs are given in table 14-27 in the appendix.

9.4.2 Sensitivity Investigations Regarding Several Variables

Descriptions regarding the different following comparisons are given in general in chapter 9.2 and more in detail in chapter 9.3.2.

The first investigated variable is the rate of interest (see figure 9-16). For the whole relevant range the combination BWL + GWP is the most economic option. Just for irrelevant high values of above 22% the EoP system becomes cheaper.

The detailed values of the related intersection points are given in table 14-37 in the appendix.

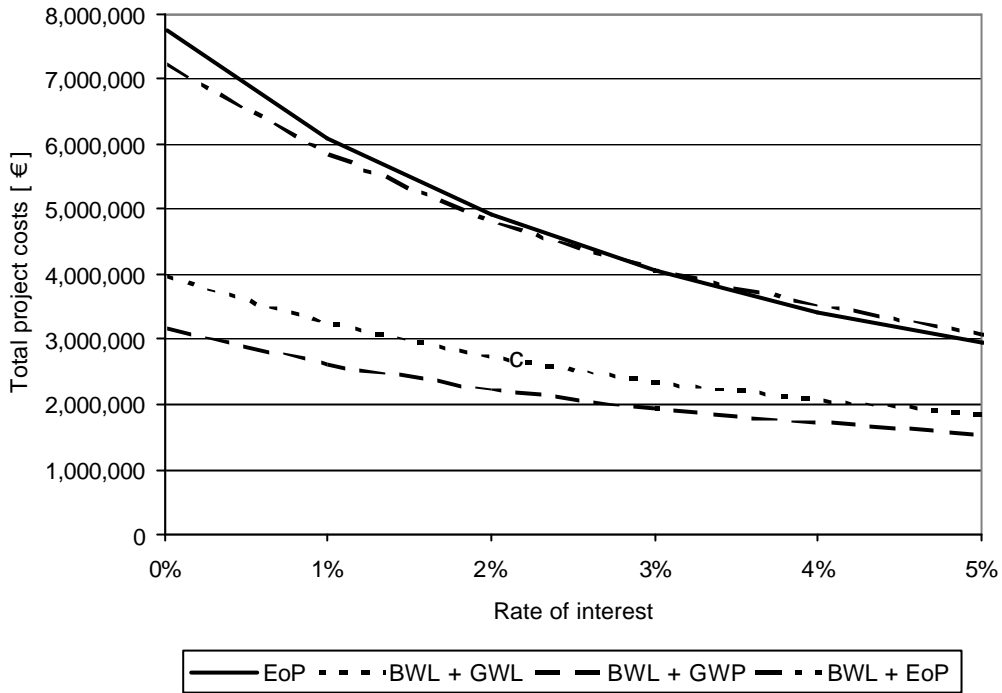

Figure 9-16: Results of sensitivity investigations on varying rates of interest on the application of the systems in an office building

Resulting from the variation of the drinking water fees (see figure 9-17) the combination BWL + GWP is the most economic option for values below 388% (5.89 €/m³). Above this level the combination BWL + GWP becomes cheaper. Although the effect on the EoP system is the highest (biggest gradient of the graph) even for a value of 0% the EoP system does not become the cheapest option. The values of the intersection points are given in detail in table 14-38.

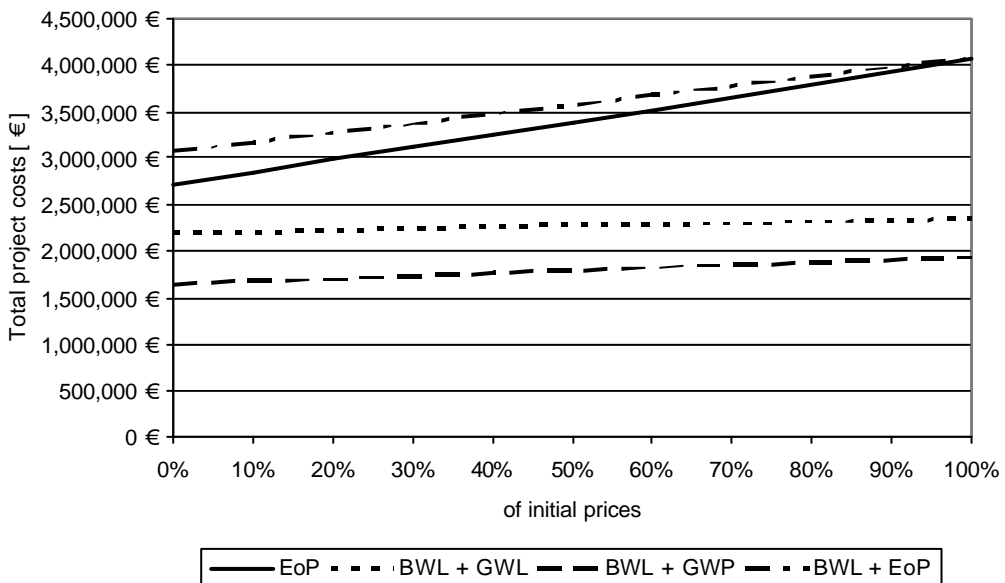

Figure 9-17: Results of sensitivity investigations on varying drinking water fees on the application of the systems in an office building

As the waste water is purified and infiltrated locally for the completely decentral systems no effect of a variation of the waste water fees on these two options occurs and values are stable (see figure 9-18). For not realistic values below 7% (0.19 €/m³) the EoP system is the cheapest solution. But for the whole realistic range of values of future waste water fees the combination BWL + GWP is the most economic option.

The values of the related intersection points are given in table 14-39.

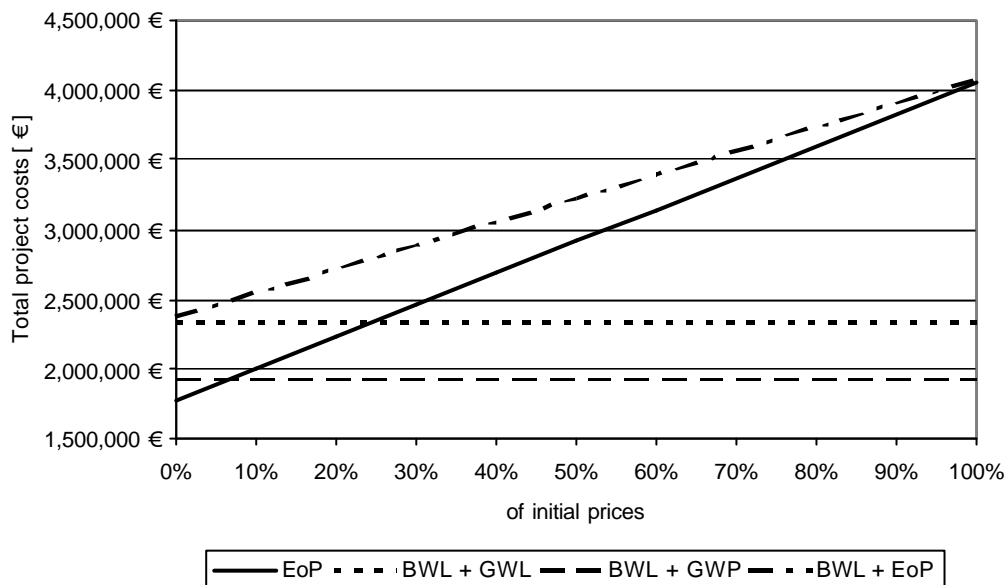

Figure 9-18: Results of sensitivity investigations on varying waste water fees on the application of the systems in an office building

For an exceptional reduction of the drinking water and waste water fees of below 37% (0.56 €/m³ drinking water and 0.95 €/m³ of waste water) of the current value in Hamburg, the EoP system becomes the most economic option (see figure 9-19). For values above this and below a second limit of 388% the combination BWL + GWP is the cheapest solution. Just for very high increases of the fees of 388 and more percent (drinking water price of 5.89 €/m³ and waste water fees of 10.01 €/m³) the combination BWL + GWP becomes cheaper.

All values of the intersection points are displayed in table 14-40 in the appendix.

For a variation of the energy price and constant water fees the combination BWL + GWP is the most economic combination (see figure 9-20). Just for extremely high and not realistic values of above 2531% (energy price of 3.74 €/kWh) the EoP system becomes economically more efficient.

The values of the found intersection points are given in table 14-41.

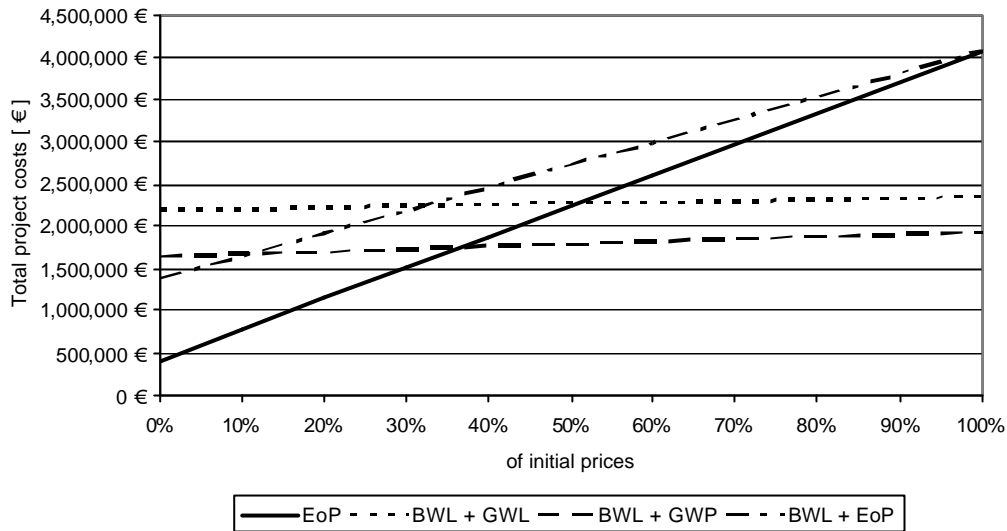

Figure 9-19: Results of sensitivity investigations on varying drinking and waste water fees on the application of the systems in an office building

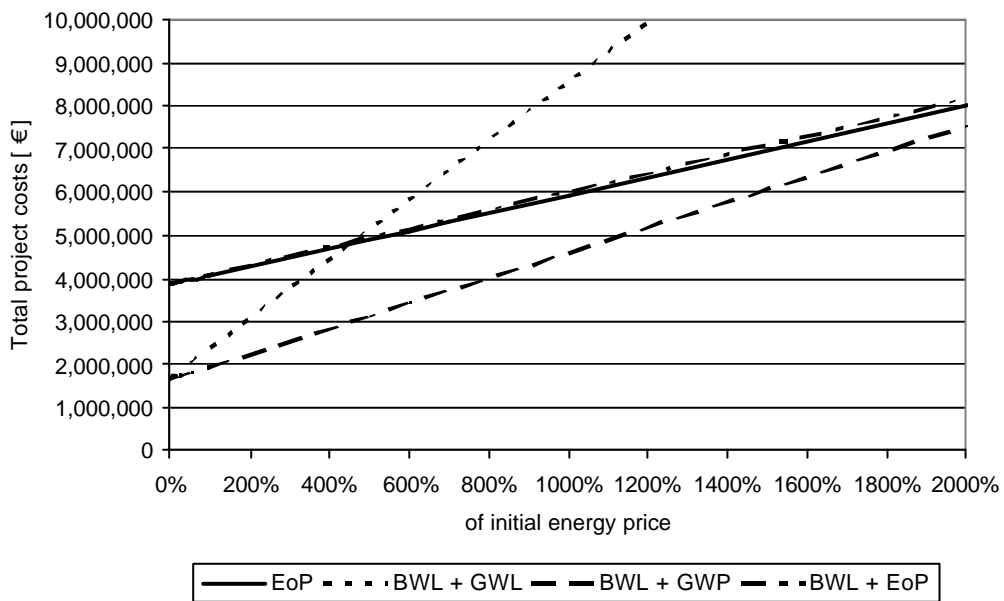

Figure 9-20: Results of sensitivity investigations on varying energy prices and constant water fees on the application of the systems in an office building

For a variation of the energy price respecting the direct influence on the water fees (energy consumption for treatment) and a waste water fee corresponding with the water contamination the combination BWL + GWP is the most economic option (see figure 9-21). Just for extremely high values of above 15,262% (energy price: 22.53 €/kWh, drinking water price: 6.82 €/m³, waste water fee: 14.14 €/m³) the combination BWL + EoP becomes cheaper.

All found intersection points and the related prices are listed in table 14-42.

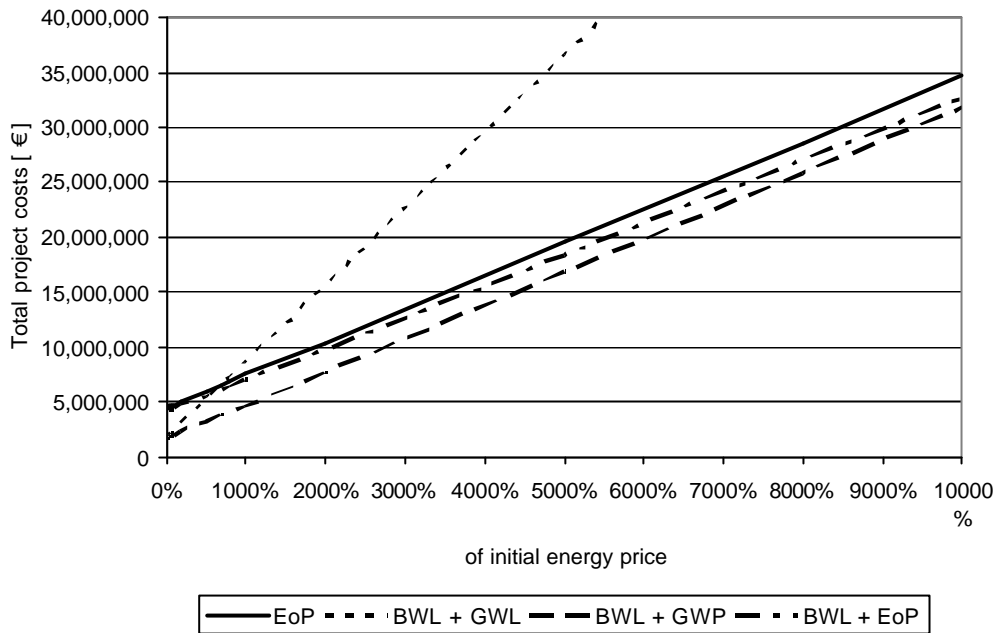

Figure 9-21: Results of sensitivity investigations on varying energy prices respecting the direct effect on the water fees and contamination related waste water fees on the application of the systems in an office building

The parallel variation of the energy price, the drinking water price and the waste water fee led to the result that the combination BWL + GWP is the most economic solution (see figure 9-22), if no exceptional and not realistic reduction of values below 35% (energy price: 0.05 €/kWh, drinking water price: 0.53 €/m³, waste water fee: 0.90 €/m³) occurs. Below this value the EoP system would be the cheapest option.

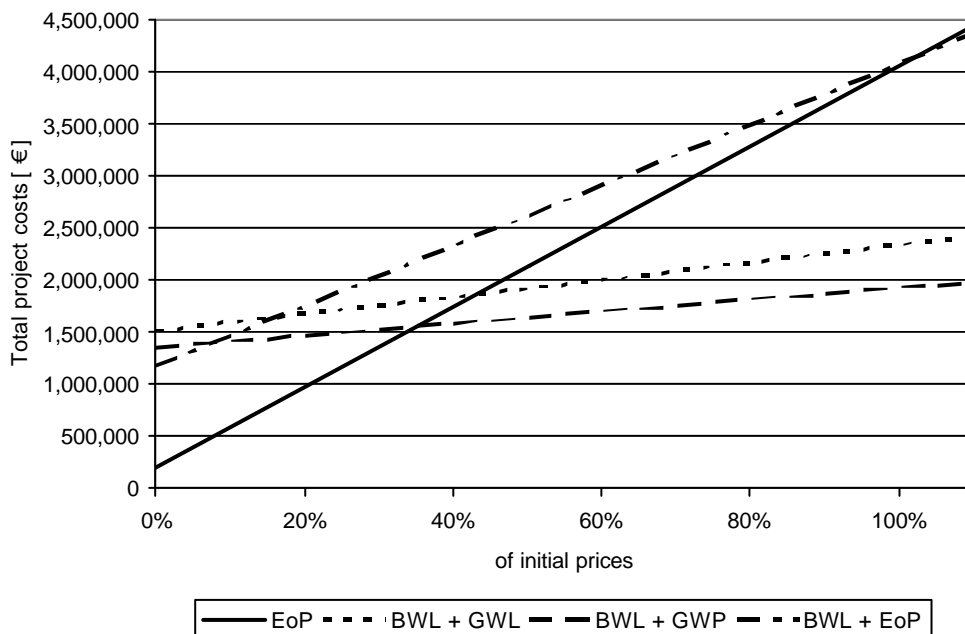

Figure 9-22: Results of sensitivity investigations on varying energy prices and drinking water and waste water fees on the application of the systems in an office building

The found intersection points for above mentioned variation are listed in table 14-43.

If the percentage of the surcharge for engineering etc is varied, the combination BWL + GWP remains the cheapest option up to a limit of 543%. Above this limit the EoP system is the most economic solution for this office building (see figure 9-23). The costs for the EoP system remain stable in this variation as this system is not affected by this surcharge (see chapter 9.2).

All found intersection points are listed in table 14-44.

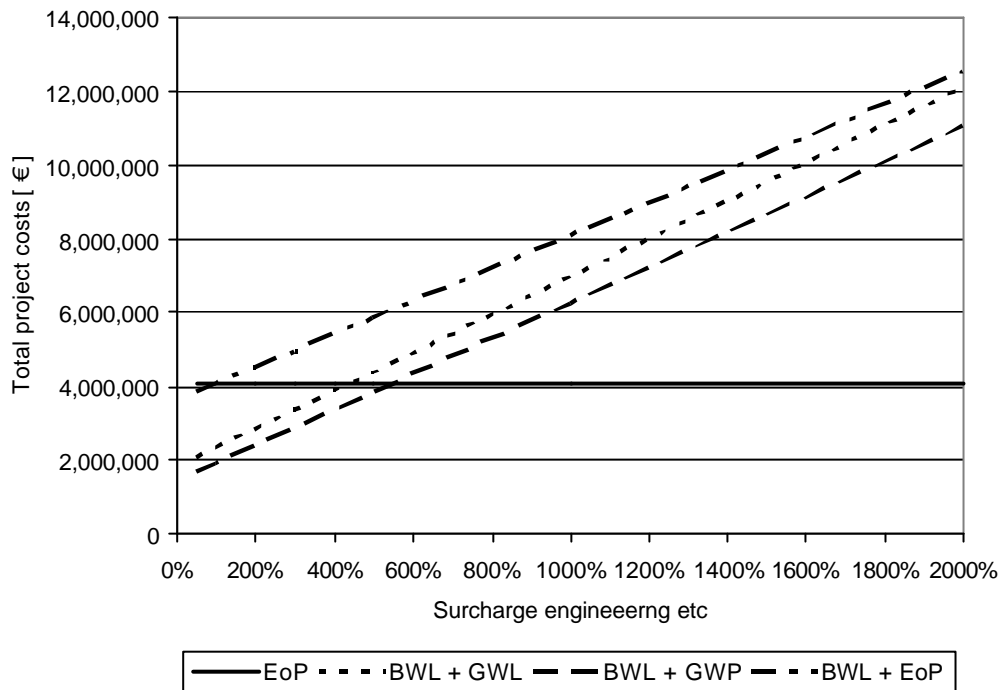

Figure 9-23: Results of sensitivity investigations on varying the surcharge for engineering etc on the application of the systems in an office building

9.4.3 Results of Comparison for Application in Office Buildings

The investigations for the initial values showed that for an application in an office building of this size the EoP system is the most expensive solution, if the waste water fees are not calculated according to the water contamination (see chapter 9.4.1). The most economic option always was the combination of the BWL + GWP.

The results of the investigations for the initial values depend on the selection of these start values. Hence, a check of important variables regarding the sensitivity of the results on changes of these values is an important investigation. The rate of interest, the drinking water and waste water fees, the energy price, and a surcharge for engineering etc have been varied in different combinations during these tests. Like for the evaluation of the application in a hotel even for the office building for all variations the system combination BWL + GWP was the most economic option, if just the for Germany realistic range is taken into account. Just for very high respective low values the combination BWL + GWL or the EoP system become the more beneficial solutions.

9.5 Evaluation of Cost Comparison for the Application in Residential Buildings

The calculated residential building contains flats for about 2000 inhabitants. It was estimated that the additional amounts generated by visitors are equal to the reductions of the amount by absence of inhabitants (holidays, working time etc.).

9.5.1 Comparison for Initial Values

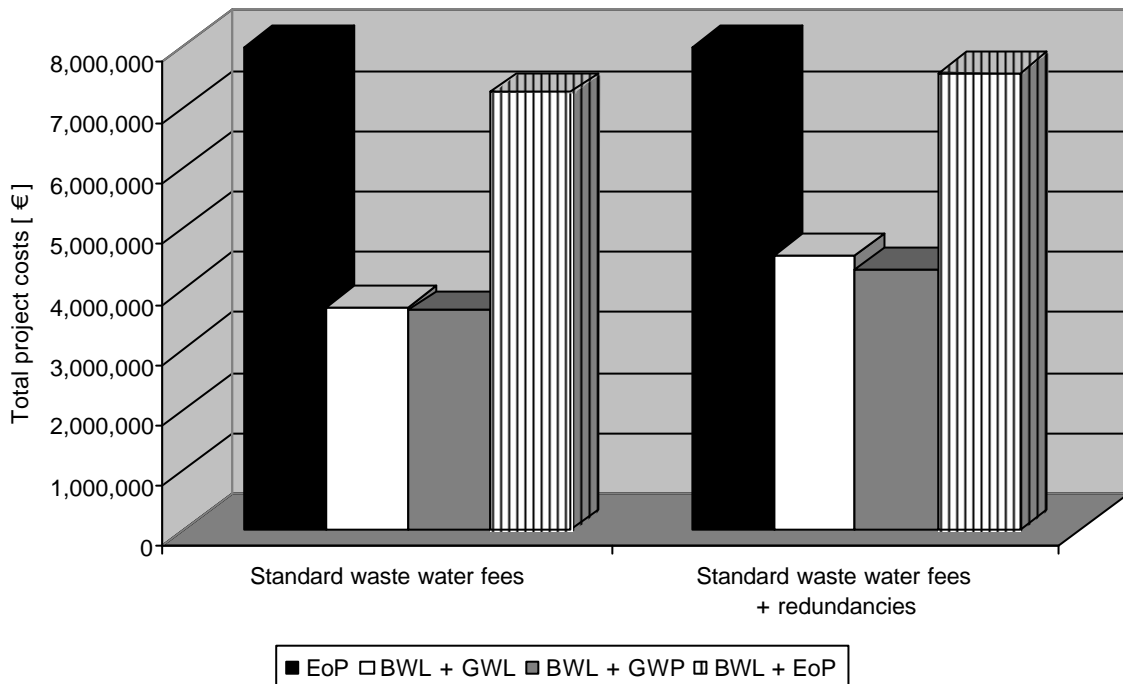

Figure 9-24: Total project costs for a residential building calculated by initial values for variables and standard fees for the conventional system

For a calculation by standard waste water fees (see chapter 9.2) the combination of black water loop and grey water purification (BWL + GWP) is the cheapest option, whilst the end-of-pipe system (EoP) is the most expensive one. Compared to the combination BWL + GWP the conventional EoP system is 2.2 times more expensive without and about 1.8 times more expensive with consideration of redundancies for all technical equipments in the decentral systems.

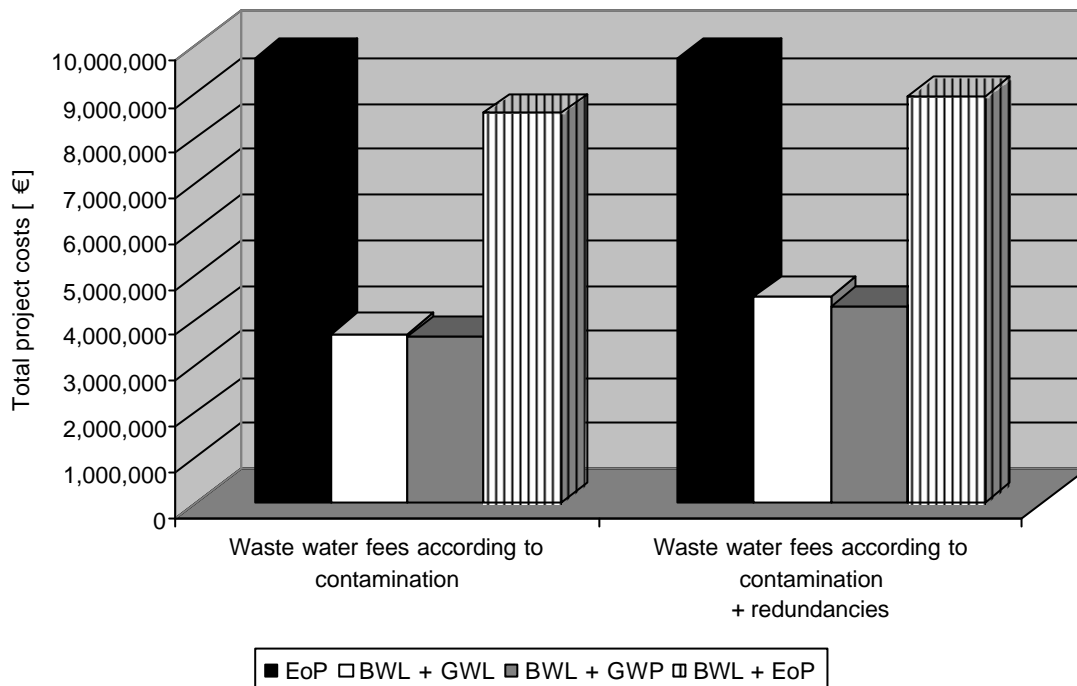

Figure 9-25: Total project costs for a residential building calculated by initial values for variables and waste water fees according to contaminations for the conventional system

Also for these circumstances the combination BWL + GWP is the cheapest and EoP the most expensive option. The economic advances of the investigated combinations with the black water loop are increased by the calculation with contamination related waste water fees (see chapter 9.2). Compared to the combination BWL + GWP the conventional EoP system is 2.7 times more expensive without and 2.3 times more expensive with consideration of redundancies for all technical equipments in the decentral systems.

The costs of the combinations BWL + GWP respective BWL + GWL are similar for all of these investigated cases. Especially for the versions without redundancies for all technical elements in the decentral systems the costs of the BWL + GWL set up are nearly equal.

The detailed values expressed as total project costs as well as annual costs are given in table 14-28 in the appendix.

9.5.2 Sensitivity Investigations Regarding Several Variables

Descriptions regarding the different following comparisons are given in general in chapter 9.2 and more in detail in chapter 9.3.2.

The variation of the rate of interest led to similar costs for the combinations BWL + GWL respective BWL + GWP. Below rates of interest of 8% (relevant range) the combination BWL + GWP is the most economic option. Just above this limit and below 23% the combination BWL + GWL is the cheapest solution. Above 23% the EoP system becomes the cheapest version.

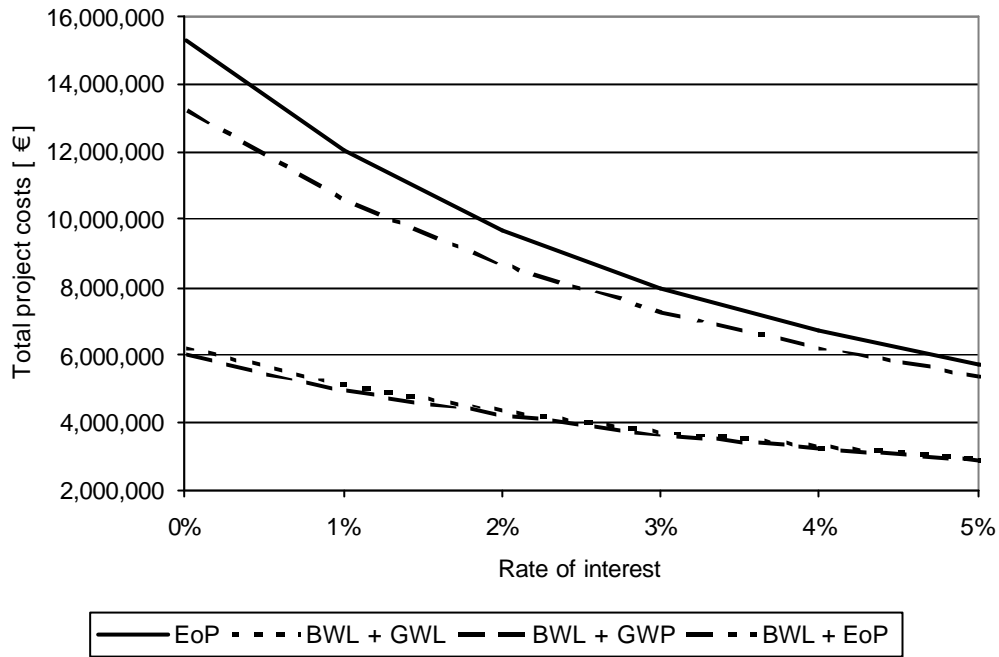

Figure 9-26: Results of sensitivity investigations on varying rates of interest on the application of the systems in a residential building

Regarding a variation of the drinking water fee (see figure 9-27) the system combination BWL + GWP is the most economic option for values below the current costs, but for an increase up to a value of above 108% (1.65 €/m³) the combination BWL + GWL becomes the cheaper solution. The exact values for the point of intersection are given in table 14-46.

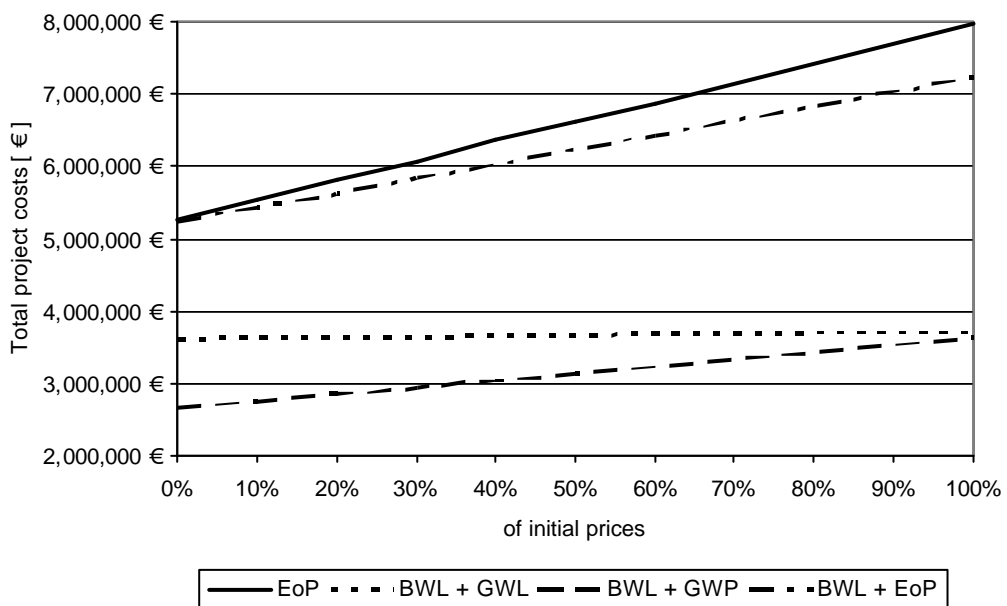

Figure 9-27: Results of sensitivity investigations on varying drinking water fees on the application of the systems in a residential building

If the price for waste water is varied for the residential building (see figure 9-28), the system combination BWL + GWP is remains the most economic option except for an exceptional decrease of this fee of values below 5.5% of the current value (0.14 €/m³). Below this limit the EoP system becomes the cheaper solution.

The intersection points related to this investigation are given in table 14-47.

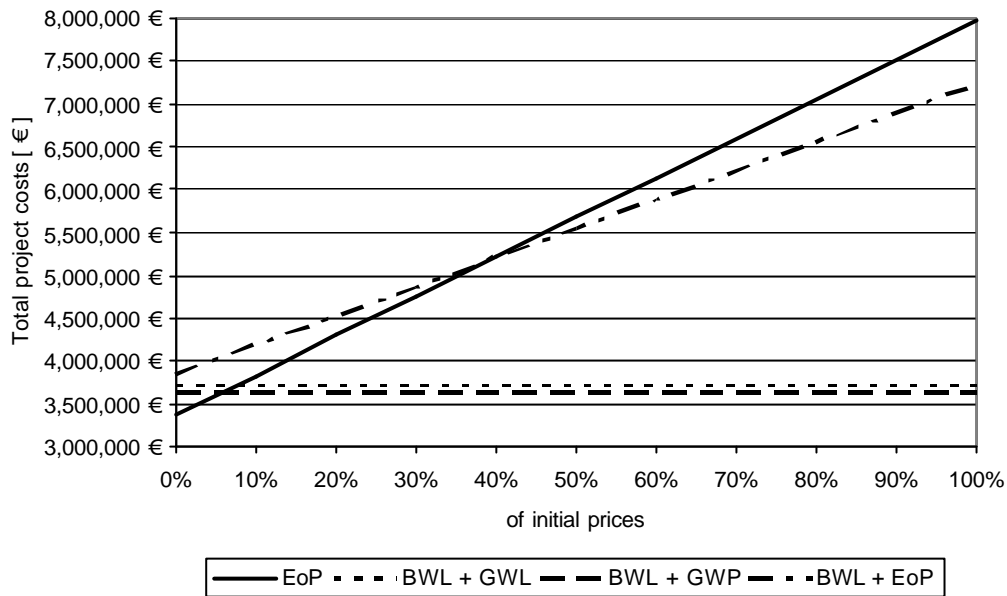

Figure 9-28: Results of sensitivity investigations on varying waste water fees on the application of the systems in a residential building

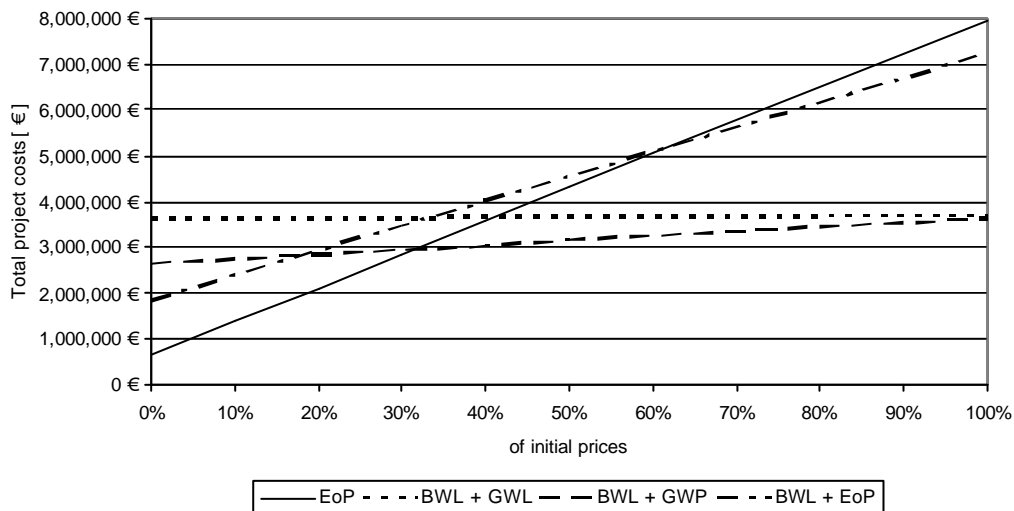

Figure 9-29: Results of sensitivity investigations on varying drinking and waste water fees on the application of the systems in a residential building

A simultaneous variation of the drinking water and waste water fees (see figure 9-29) results in fact, that the EoP system is the cheapest solution for very low levels of fees below 31% of the current status in Hamburg (drinking water price: 0.48 €/m³, waste water fee: 0.81 €/m³). For the range between 31% and 108% (drinking water price: 1.65 €/m³, waste water fee: 2.80 €/m³) the combination

BWL + GWP is the most economic option. For an increase of above 108% the combination of BWL + GWL becomes the most efficient option regarding economic aspects.

A list with the data of the intersection points is given in table 14-48 in the appendix.

The price of the energy was varied during these investigations respecting different circumstances (see chapter 9.3.2). For a variation of the energy price with constant water fees these investigations result in the in figure 9-30 shown total project costs. For values below 91% (0.13 €/kWh) the system combination BWL + GWL is the cheapest option. Above this limit and below values of about 2,079% (3.07 €/kWh) the combination BWL + GWP is the most economic solution. Between 2,079% and 9,726% (14.36 €/kWh) the system combination BWL + EoP is the cheapest variation. Above this level the EoP system is the most economic option.

Respecting just realistic ranges of price variation the combinations BWL + GWL respective BWL + GWP are the most economic options for this application.

All detailed values for this variation are listed in table 14-49.

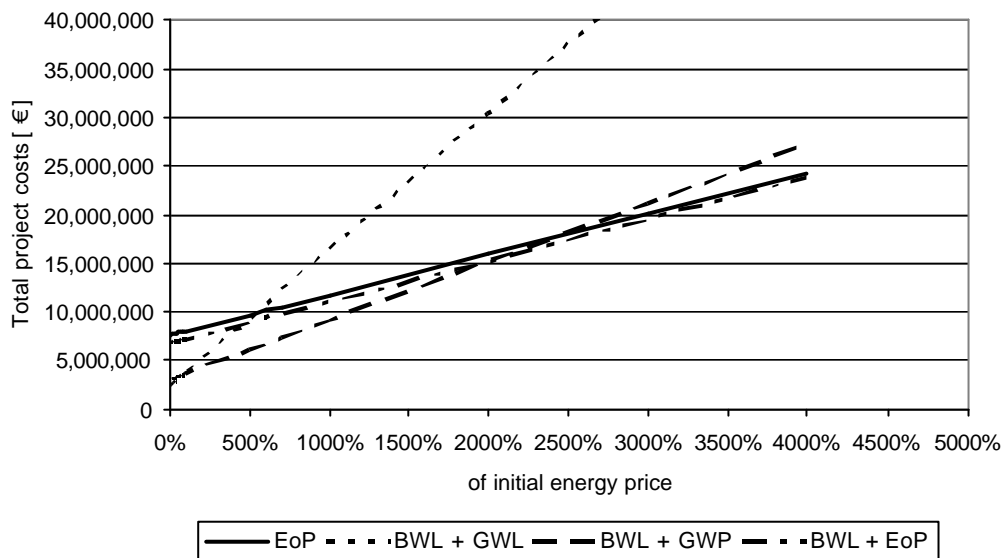

Figure 9-30: Results of sensitivity investigations on varying energy prices and constant water fees on the application of the systems in a residential building

The next investigation deals with a variation of the energy price respecting the direct effect on the waste water and drinking water fees. For values below 90% (energy price: 0.13 €/kWh, drinking water price: 1.52 €/m³, waste water fees: 3.57 €/m³) the system combination BWL + GWL is the cheapest option. Above this level and below 9282% (energy price: 13.70 €/kWh, drinking water price: 4.73 €/m³, waste water fees: 10.91 €/m³) the combination BWL + GWP becomes the most economic solution. Above the upper level the combination BWL + EoP is the best solution regarding economic aspects. As values of more than 9000% price increase are not realistic, just the combinations BWL + GWL respective BWL + GWP are relevant results of this investigation.

All found intersection points and the related data is listed in table 14-50.

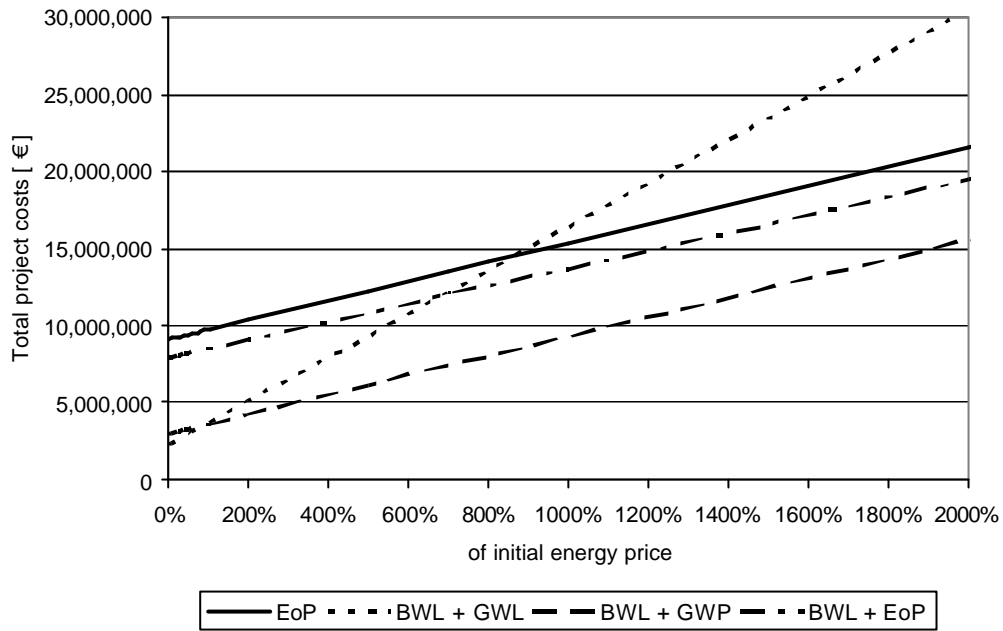

Figure 9-31: Results of sensitivity investigations on varying energy prices respecting the direct effect on the water fees and contamination related waste water fees on the application of the systems in a residential building

A comparison of the system combinations for a parallel variation of the energy, drinking water, and waste water prices led to the graphs shown in figure 9-32. Below 29% (energy price: 0.04 €/kWh, drinking water price: 0.45 €/m³, waste water fees: 0.76 €/m³) the EoP system is the cheapest option. Above this level and below a second limit of about 189% (energy price: 0.28 €/kWh, drinking water price: 2.87 €/m³, waste water fees: 4.87 €/m³) the combination BWL + GWP is the most economic option. Above this second limit the combination BWL + GWL becomes the cheapest solution. All found intersection points related to this investigation are listed in table 14-51.

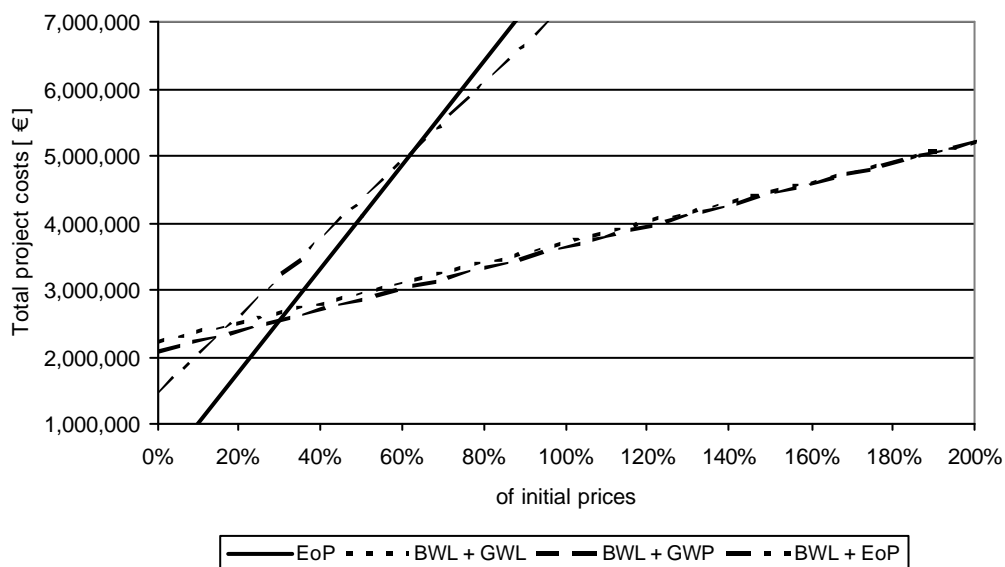

Figure 9-32: Results of sensitivity investigations on varying energy prices and drinking water and waste water fees on the application of the systems in a residential building

The variation of the surcharge for engineering etc for the decentral systems leads to the graphs displayed in figure 9-33. Below a level of 628% of surcharge the combination BWL + GWP is the most economic option. Above this limit the EoP system is the cheapest solution. All intersection points of this investigation are listed in table 14-52.

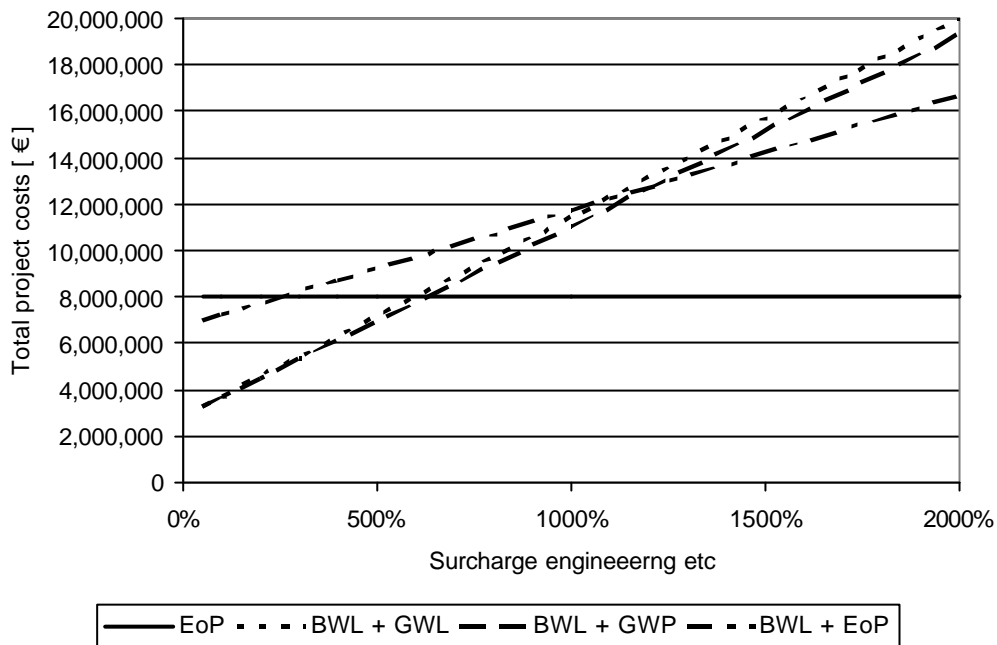

Figure 9-33: Results of sensitivity investigations on varying the surcharge for engineering etc on the application of the systems in a residential building

9.5.3 Results of Comparison for Application in a Residential Building

The investigations for the initial values showed that for an application in a residential building of this size the EoP system is the most expensive solution (see chapter 9.5.1). The most economic option always was the combination of the BWL + GWP, but the combination BWL + GWL is just slightly more expensive.

The sensitivity investigation on several variables (see chapter 9.5.2 and 9.2) led to the result that for the most cases the system combination BWL + GWP is the most economic option. For a variation of the drinking water price this combination is just the best solution if the fees decrease from the current value in Hamburg. For increasing water prices the combination BWL + GWL becomes more cost efficient. The EoP system just becomes the most beneficial solution, if values decrease respective increases extremely (not to be expected). Hence, for the application in a residential building of this size in Hamburg just the implementation of the combinations BWL + GWP or BWL + GWL are the best options from the economic point of view.

9.6 Conclusions of Cost Comparison Analysis

For initial values (with and without redundancies) always the combination of black water loop with the grey water purification for service water reuse (BWL + GWP, see table 9-1) is the cheapest combination. This set up is between 1.7 and 3.2 times cheaper than the conventional end-of-pipe system. In most cases the end-of-pipe system is the most expensive solution. Just for an application in an office building and calculation of the end-of-pipe system according standard (non contamination related fees) the combination of the black water loop with the application of the end-of-pipe system for grey water disposal (BWL + EoP) is more expensive. For all other cases any of the investigated combinations with the black water loop are more beneficial from the economic point of view than the conventional system.

By varying several values (see chapter 9.2) it is possible to make the EoP system the most economic option, but this always is just the case for not realistic (very high or very low) values. For the combination BWL + EoP it is similar.

Just respecting realistic ranges of the varied values, for an application in a hotel or an office building always the system combination BWL + GWP is the most economic option. Even for an application in a residential building this is the best solution for the most cases. But for an increasing price of drinking water the combination BWL + GWL becomes the more economic solution for residential buildings of this size.

For buildings of this size (2000 users) an application of the BWL can be a very economic option for a building in Hamburg (or in cities with similar circumstances). This is especially the truth, if the black water loop is combined with a system for grey water purification. Even for a variation of several variables (see chapter 9.2) this remains the truth, if the values are kept in realistic ranges.

Table 9-8: Energy demand of compared system combinations for the application on a hotel

[46]: [Schuster, M., 2007]

	EoP	BWL + EoP	BWL + GWL	BWL + GWP	Reference
Hotel					
Drinking water demand [l/pers*d]	190	140	15	43	
Energy demand for drinking water generation [kWh/pers*d]	0.102	0.075	0.008	0.023	[46]
Black water amount [l/pers*d]	50	50	50	50	
Energy demand for black water purification [kWh/ pers*d]	0.096	0.235	0.235	0.235	
Grey water amount [l/pers*d]	140	140	140	140	
Energy demand for grey water purification [kWh/pers*d]	0.042	0.042	0.715	0.140	
Energy demand for fertilizer production [kWh/pers*d]	0.150	0.000	0.000	0.000	
Sum of energy demand [kWh/pers*d]	0.390	0.352	0.958	0.398	

As by-product of the calculations for the cost comparison the energy demand for drinking water generation, waste water purification and fertilizer production have been calculated. For this reason these values are listed here (see tables 9-8 to 9-10) as additional information even when this dedicated comparison is not part of the cost comparison in general.

Table 9-9: Energy demand of compared system combinations for the application on an office building
[46]: [Schuster, M., 2007]

	EoP	BWL + EoP	BWL + GWL	BWL + GWP	Reference
Office building					
Drinking water demand [l/pers*d]	47.5	35	5	10	
Energy demand for drinking water generation [kWh/pers*d]	0.026	0.019	0.003	0.005	[46]
Black water amount [l/pers*d]	12.5	12.5	12.5	12.5	
Energy demand for black water purification [kWh/pers*d]	0.048	0.080	0.080	0.080	
Grey water amount [l/pers*d]	35	35	35	35	
Energy demand for grey water purification [kWh/pers*d]	0.005	0.005	0.171	0.027	
Energy demand for fertilizer production [kWh/pers*d]	0.075	0.000	0.000	0.000	
Sum of energy demand [kWh/pers*d]	0.153	0.103	0.253	0.112	

The application of the black water loop (BWL + EoP) decreases the energy demand compared to conventional system (EoP) and for all types of investigated buildings results in the lowest demands. The energy demand of the grey water loop is high. Hence, the combination with this technique (BWL + GWL) for all buildings results in the highest energy demands. The combination with the grey water purification for service water reuse (BWL + GWP) leads to energy demands similar (hotel) or lower (office or residential building) than the conventional system (EoP). The amount of energy for construction is not included here.

Table 9-10: Energy demand of compared system combinations for the application on a residential building

[46]: [Schuster, M., 2007]

	EoP	BWL + EoP	BWL + GWL	BWL + GWP	Reference
Residential building					
Drinking water demand [l/pers*d]	95	70	3	34	
Energy demand for drinking water generation [kWh/pers*d]	0.051	0.038	0.002	0.018	[46]
Black water amount [l/pers*d]	25	25	25	25	
Energy demand for black water purification [kWh/pers*d]	0.096	0.156	0.156	0.156	
Grey water amount [l/pers*d]	70	70	70	70	
Energy demand for grey water purification [kWh/pers*d]	0.021	0.021	0.351	0.062	
Energy demand for fertilizer production [kWh/pers*d]	0.150	0.000	0.000	0.000	
Sum of energy demand [kWh/pers*d]	0.318	0.215	0.509	0.237	

10 Conclusions

Objective of this thesis was to develop a system for black water purification for its reuse as toilet flush water, which fulfils all hygienic as well as aesthetic needs (black water loop). Additionally, the nutrients contained in the black water stream should be reused, instead to be eliminated in a complex process on a waste water treatment plant.

The results of this thesis prove the technical feasibility of the black water loop concept, as a pilot plant, which was constructed at the Institute of Waste Water Management and Water Protection of the Hamburg University of Technology (TUHH), was operated for about 16 months.

Within this dissertation all necessary purification technologies for the black water loop were selected and tested regarding their applicability. Tests were carried out in lab scale experiments as well as in the above mentioned pilot plant.

These investigations resulted in four core statements:

- **Biological treatment:** Despite high nitrogen concentrations in the inflow a stable biological treatment of black and yellow water with a stable nitrification was possible.
- **Smell:** Even for this highly concentrated waste water stream the removal of the odour was possible simply by biological treatment.
- **Odour:** Between all tested technologies just the treatment by ozone respective by UV-C irradiation (including wavelength of 185 nm) was successful in complete and permanent colour removal.
- **Pathogens:** Control of germs showed that the hygienic needs were completely fulfilled by the selected purification steps.

For the biological treatment an adaptation of the bacteria on treatment of yellow water was carried out in lab scale prior to the start of the pilot plant with the treatment of the pre-sieved black water. The adapted biomass ensured a stable biological treatment even for total nitrogen concentrations of about 1,400 mg/l for the pilot plant and more than 3,400 mg/l in the lab scale experiments. The adapted biomass worked stable even for increases of the nitrite nitrogen concentrations up to values of more than 700 mg/l and reduced these concentrations in a self regulating way down to values below 10 mg/l $\text{NO}_3\text{-N}$ again. The biological treatment mainly took place at temperatures above 12°C and in a pH range between 7.5 and 8.5. The pH was controlled by addition of bases.

Because of the construction constraints the reactor for biological treatment was rather huge compared to the inflow. This resulted in long retention times of in average about 700 h (29 days). This low feeding resulted in no need for access sludge removal.

As already mentioned above, the biological treatment resulted in a complete removal of the odour of this very concentrated partial flow. The liquid remained even odour free during storage of several days.

A further positive effect of the biological treatment is the reduction of the tendency to form foam.

Several technologies for the removal of colour have been tested in lab scale experiments. Activated carbon adsorption, ultrasonification, UV-C irradiation (not including light of the wavelength of about 185 nm), UV-A irradiation with different combinations of pH-adjustment and addition of TiO_2 respective H_2O_2 have been tested without a sufficient effect yellow water. A complete decolourisation was just reached by application of ozone or UV-C light including the wavelength of 185 nm. Both technologies proved their applicability even in the pilot scale investigations.

The energy demand for the decolourisation can be reduced by biological pre-treatment. Lab scale experiments with different concentrations of urine resulted in the subsequent listed values for the energy demand per percent of urine content of the treated stream.

Table 10-1: Energy demand for the complete decolourisation per percent of urine content

Treatment technology	Unit	Biological pre treatment		No biological pre treatment	
		recolouring	no recolouring	recolouring	no recolouring
Ozone	[kWh/(m ³ *% of urine content)]	0.5 - 0.7	4.1 - 6.6	0.8 - 2.1	20.4
UV-C radiation	[kWh/(m ³ *% of urine content)]	-	24.3 - 53.8	-	147.4 - 238.5

To enable an objective measurement of the colour perception by human eyes a complex calculation system has been introduced in chapter 3.8.3. For all measurements the calculation of the colourfulness of the liquid was done according to German standards [DIN 5033, Part 3, 1992].

The tests on the amounts of total coliforms and e-coli in the purified water resulted in low germ concentrations. The found values fulfil all the limits of relevant regulations (table 7-3 and chapter 7.6.2). The re-use of this water for toilet flushing does not lead to hygienic dangers. The doses of ozone respective UV-C, which are necessary for a complete colour removal, are absolutely sufficient for a second (additionally to the ultrafiltration) security regarding germs. According to literature values also a complete removal of micro pollutants should be reached by these doses.

Table 10-2: Concentrations of germs found during three series of measurement in purified liquid from the pilot plant taken subsequent the ultrafiltration prior respective subsequent UV treatment

Sample taken ...	Average of the four incubations	
	Escherichia coli	Total coliforms
subsequent UV treatment	0	44
subsequent UV treatment	0	63
prior UV treatment	5	43

An internal and anonymous investigation led to very good results regarding the user acceptance of the system. The black water loop as well as the concept of a grey water loop (purification of grey water for its reuse as drinking water) have been investigated. The survey was constricted to technically informed members of the AWW Institute and the total number of interviewed persons was limited to 18 persons. Hence, these results give an interesting indication, but these can not be seen as representative for the common toilet user.

Between the technically informed members of the AWW institute there was a 100% acceptance of the technology for the application in the institute. No one responded that any doubt regarding the technology has been the reason not to use the toilet. Aspects like the long distance between the offices and the toilet and a missing privacy in the toilets (which have been placed directly inside the test hall) have led to a limitation in the use.

Questions regarding the implementation of a black water respective grey water loop in the private houses of the AWW Institute members led also to rather positive results. 61.1% would support and at least the remaining 38.9% would accept the implementation of a black water loop system. Regarding the grey water loop the acceptance was lower. 22.2% of the respondents would decline the implementation in their houses. Main reason to decline the system was that the people want the security of a passage through the soil for their drinking water. The second reason was that there is no water scarcity in Germany and therefore from their point of view no reason for this implementation

exists. So to use a passage through the ground for the grey water cycle would remove even here all technical doubts.

The economic benefits have been investigated by a cost comparison between combinations of the black water loop with two different systems for grey water purification on the one and the conventional end-of-pipe system on the other hand. Regarding the black water loop a decolourisation by nanofiltration was assumed for the calculations. These investigations have been carried out for three different types of buildings with a size of 2,000 users each:

- A hotel,
- an office building,
- and a residential building

Especially the combinations of the black water loop with systems for decentral grey water purification and reuse are much more economic than the conventional central waste water plant at this size. For the initial values (current values for Hamburg, Germany) the decentral systems are up to 3.2 times cheaper than the conventional end-of-pipe system. Tests regarding the sensitivity of several variables proved, that these decentral system combination remain the cheapest options also for major changes of the economic circumstances. Just for very extreme and not realistic changes of the economic circumstances the conventional end-of-pipe system became the cheapest option.

Possibilities for future system optimisations as well as hints for the up-scaling and related system adjustments are listed in chapter 8.2. These values have been derived from the experiments as well as from literature reviews.

The energy demand of the investigated solutions for colour removal is high (see table 10-1). Nanofiltration and stripping of nitrogen are possible techniques to reduce the energy demand. Also intermittent biological and ozone treatment is an option for a further increase of the system efficiency. A listing of possibilities for optimisation of the system is given in the chapters 8.1 and 8.2.

In chapter 8.3 risks regarding the application of the black water loop have been investigated. Countermeasures for all of these risks have been listed.

Concluding from all these results can be stated that the concept of the black water loop is a technically, economically, and ecologically very promising option for decentral approaches with separated waste water streams. And it is worth to be investigated in more detail to generate a marketable product of it.

11 Outlook

The overall future objective is to generate a marketable product out of the concept of the black water loop. To reach this aim, further advances on several issues need to be reached.

As direct extension of this thesis further experiments (lab and pilot scale) should be conducted to reach an optimisation of the system in general and especially to improve the efficiency of the decolourisation. Regarding an efficient removal of colour tests with nanofiltration membranes should be carried out. Next to these test on the general applicability of these membranes also investigation regarding scaling on the membrane surfaces need to be undertaken. The chapters 8.1 and 8.2 of this thesis deal with further options for future improvements and experiments.

The implementation of a full scale plant and the acceptance investigation with “common” users will be a further important step to reach the marketable status of the product as well as it will lead to more detailed design values and more reliable data regarding the energy demand. Both aspects will allow a further increase in the accuracy of the calculations cost efficiency of the overall system respective of system combinations. An extension of the cost calculations for smaller houses and settlements (e.g. 100 – 500 users) will complete the investigations of this thesis regarding the sizing aspect. To calculate the costs comparison in detail for a large scale implementation project will be the final step regarding this issue.

The idea and a possible set up for the grey water loop are discussed in this thesis. To develop this system would allow planning and realisation of complete waste water free houses.

The last step of development will be the design of standard elements for the black water (and may be also for the grey water) loop. These standard elements will ease the cost estimation for projects and decrease the costs for engineering and manufacturing.

12 References

- "Kanalzustand ist erbärmlich" (2007). *KA*, 54 (5), pp. 443.
- Abbauverhalten von Einzelstoffen in Kläranlagen (2004). *KA*, 51 (10), pp. 1054.
- Abwasserreinigung mit Membrantechnik* (2003). Ministerium für Umwelt und Naturschutz, Landwirtschaft und Verbraucherschutz des Landes Nordrhein-Westfalen, Düsseldorf, Germany.
- Arbeitsblatt ATV-A 122 (1991). Gesellschaft zur Förderung der Abwassertechnik e.V. (GFA).
- Arbeitsblatt ATV-DVWK-A 131 (2000). Gesellschaft zur Förderung der Abwassertechnik e.V. (GFA).
- Arbeitsblatt DWA-A 138 (2005). DWA Deutsche Vereinigung für Wasserwirtschaft, Abwasser und Abfall e.V., Hennef, Germany.
- Barbiturate nach Jahrzehnten in Gewässern nachweisbar (2006). *KA*, 53 (11), pp. 1095.
- Bundesregierung sieht Chancen für Phosphorrecycling (2006). *KA*, 53 (5), pp. 448.
- Chemisch-physikalische Analyse des Reinwassers 2005 - Grundwasserwerk Neugraben (2006). Homepage of the company Hamburg-Wasser. <http://www.hamburg-wasser.de/downloads.html>.
- Chemisch-physikalische Analyse des Reinwassers 2005 - Grundwasserwerk Süderelbmarsch (2006). Homepage of the company Hamburg-Wasser. <http://www.hamburg-wasser.de/downloads.html>.
- Chemisch-physikalische Analyse des Reinwassers 2005 - Grundwasserwerk Wilhelmsburg (2006). Homepage of the company Hamburg-Wasser. <http://www.hamburg-wasser.de/downloads.html>.
- Demographischer Wandel und Infrastrukturplanung im Bundestag (2007). *KA*, 54 (5), pp. 443.
- Demonstrationsvorhaben "Dezentrale urbane Infrastruktur-Systeme" (2004). *KA*, 51 (7), pp. 708.
- Dezentrale naturnahe Regenwasserbewirtschaftung (2006). Freie und Hansestadt Hamburg - Behörde für Stadtentwicklung und Umwelt, Hamburg, Germany.
- DIN 19650: 1999-02 (1999). Deutsches Institut für Normung e.V.
- DIN 5033 (1979a). Beuth Verlag GmbH.
- DIN 5033, Part 1 (1979). Deutsches Institut für Normung e.V.
- DIN 5033, Part 2 (1992). Deutsches Institut für Normung e.V.
- DIN 5033, Part 3 (1992). Deutsches Institut für Normung e.V.

DIN 5033, Part 7 (1983). Deutsches Institut für Normung e.V.

DIN 6164 (1980). DIN Deutsches Institut für Normung e.V.

DIN EN 12 880 (2001). DIN Deutsches Institut für Normung e.V.

EcoSanRes - Closing the loop on Phosphorus (2005). www.ecosanres.org.
http://www.ecosanres.org/PDF%20files/Fact_sheets/ESR4lowres.pdf.

Grauwasser-Recycling-Anlage zur Produktion von qualitativ hochwertigem Betriebswasser (2007).
Hans Huber AG, Berching, Germany.

Homepage of the company AquaCare Systems Research (2007).
<http://www.aquacare.de/download/propekt/pd-swp.pdf>.

Homepage of the company glm-Wassertechnik (2007). www.glm-wassertechnik.de/htm/verfahren/glm_vollentsalzung.htm.

Homepage of the company Hamburg Wasser - Fees, prices (2007).
www.hamburgwasser.de/cms/website.php?id=/de/index/service/gebuehrenabgabenpreise.

Homepage of the company sterilAir (2007). www.sterilair.com.

Kleine Anfrage zur Wasserrahmenrichtlinie und zu Arzneimittelwirkstoffen (2007). KA, 54 (7), pp. 661.

Klimaveränderung und Siedlungswasserwirtschaft (2007). KA, 54 (2), pp. 125.

Kredite zur Kanalsanierung aus der Abwasserabgabe (2004). KA, 51 (10), pp. 1052.

Leitlinien zur Durchführung dynamischer Kostenvergleichsrechnungen (KVR-Leitlinien) (1998).
Länderarbeitsgemeinschaft Wasser (LAWA).

Milliardenschwere Investitionen erforderlich (2006). KA, 53 (5), pp. 448.

Mineralische Phosphatdünger können Uran enthalten (2005). KA, 52 (4), pp. 363.

Öffentliche Abwasserkanäle umspannen 13mal die Erde (2006). KA, 53 (5), pp. 448.

Organic Pollutants in the Water Cycle - Properties, Occurrence Analysis and Environment (2006).
Wiley-VCH Verlag GmbH & Co. KGaA, Weinheim, Germany.

Phosphat-Versorgungssicherheit und Bodenschutz bei Phosphatdüngern (2006). Bundesanzeiger
Verlagsgesellschaft mbH, Köln, Germany.

Price information of the company Albert Block GmbH (2007).

Price information of the company Jung Pumpen (2007).

Richtlinie des Europäischen Parlaments und des Rates über die Qualität der Badegewässer und deren Bewirtschaftung und zur Aufhebung der Richtlinie 76/160/EWG (2005). Das Europäische Parlament - Der Rat.

- Sauerstoffsättigung (Umwelt) (2007). http://de.wikipedia.org/wiki/Sauerstoffs%C3%A4ttigung_Umwelt.
- Ultraviolet disinfection (1999). United States Environmental Protection Agency (EPA).
- Wasser - intelligent nutzen - nachhaltig schützen (2006). Deutsche Bundesstiftung Umwelt (DBU),
- Weltgrößte kommunale Membrankläranlage in Betrieb (2004). *KA*, 51 (8), pp. 812.
- Wissenschaftliche Tabellen Geigy* (1977). CIBA-GEIGY AG, Basel.
- Zugang zu sauberem Trinkwasser (2005). *KA*, 52 (5), pp. 496.
- Zugang zu sauberem Trinkwasser (2006). *KA*, 53 (11), pp. 1092.
- Alexy, R. and Kümmerer, K. (2005). Antibiotika in der Umwelt. *KA*, 52 (5), pp. 563 - 571.
- Alken, P., Fornara, P., Frohneberg, D., Jocham, D., Jünemann, K.-P., Löbelenz, M., Ludwig, G., Mickisch, G., Persson-Jünemann, C., Radler, H., Rassweiler, J., Schiefer, H. G., Thüroff, J. W., Tschada, R., Walz, P. H., and Weidner, W. (1992). *Urologie*. VCH Verlagsgesellschaft mbH, Weinheim, Germany.
- Alken, P. and Walz, P. H. (1998). *Urologie*. Chapman & Hall GmbH, Weinheim, Germany.
- Andreozzi, R., Canterino, M., Marotta, R., and Nicklas, P. (2005). Antibiotic removal from wastewaters: The ozonation of amoxicillin. *Journal of hazardous materials*, 122 (3), pp. 243 - 250.
- Andreozzi, R., Caprio, V., Marotta, R., and Radovnikovic, A. (2003). Ozonation and H₂O₂/UV treatment of clofibrac acid in water: a kinetic investigation. *Journal of hazardous materials*, 103 (3), pp. 233 - 246.
- Andrews, R. K., Blakeley, R. L., and Zerner, B. (1984). Urea and urease. In: *Advances in inorganic biochemistry*, Elsevier(ed.).
- Ayres, R. M. and Mara, D. D. (1996). *Analysis of wastewater for use in agriculture: A laboratory manual of parasitological and bacteriological techniques*. World Health Organization (WHO), Geneva, Switzerland.
- Back, E., Brands, E., Dorgeloh, E., Drensla, K., Frechen, F.-B., Fuchs, W., Gnirß, R., Greil, K.-H., Rosenwinkel, K.-H., Schier, W., Schoenen, D., Stein, S., Theilen, U., van der Roest, H., Voßenkaul, K., Wedi, D., Wozniak, T., and Zastrow, P. (2005). 2. DWA Arbeitsbericht „Membranbelebungsverfahren“. Deutsche Vereinigung für Wasserwirtschaft, Abwasser und Abfall e.V. (DWA), Hennef, Germany.
- Bahr, C., Ernst, M., Heinzmann, B., Jekel, M., Luck, F., and Ried, A. (2007). Ozonung von gereinigtem Abwasser zur Spurenstoffentfernung und Desinfektion. *KA*, 54 (9), pp. 902 - 908.
- Behrendt, J., Deegener, S., Meinzinger, F., Gajurel, D. R., Shalabi, M., Wendland, C., and Otterpohl, R. (2006). Appropriate de-central wastewater technologies for low income regions. In: *Dry Toilet 2006, 2nd International Dry Toilet Conference*, 16. - 19.08.2006, Tampere, Finland.
- Beise, D. (2007). Tender of the company Werner Grube GmbH & Co. Personal communication.

- Bellefontaine, K., Holtkamp, O., Thaler, S., Leptien, C., Herkner, T., and Sieler, A. (2007). Wirtschaftsdaten der Abwasserentsorgung 2005 - Ergebnisse einer gemeinsamen Umfrage der DWA und des BGW. *KA*, 54 (5), pp. 493 - 497.
- Berger, C. and Lohaus, J. (2005). Zustand der Kanalisation - Ergebnisse der DWA-Umfrage 2004. *KA*, 52 (5), pp. 528 - 539.
- Bever, J., Bode, H., Dorias, B., Gebert, W., Jardin, N., Kruse, H. D., Mehlhart, G., Roth, M., Schlegel, S., Schwentner, G., and Steinmann, G. A. (2002). Neue Erkenntnisse über Anlagen mit getauchtem Festbett - Arbeitsbericht of the ATV-DVWK Arbeitsgruppe KA-6.3. *KA*, 49 (12), pp. 1703 - 1714.
- Bierstedt, S. and Heine, A. (2005). Das abflusslose Grundstück - Eine Bilanzierung unter den Bedingungen des Landes Brandenburg. *KA*, 52 (2), pp. 153 - 157.
- Bischof, F. and Meuler, S. (2004). DeSa/R - A Pilot System in Huber Administration Building. In: *DeSa/R-Symposium 2004, Berching, Germany*.
- Bischof, F. and Paris, S. (2007). New aspects for wastewater treatment after urine separation. In: *Advanced Sanitation, 12. - 13.03.2007, Aachen, Germany*.
- Blumenthal, U. J. and Peasey, A. (2002). Critical review of epidemiological evidence of the health effects of wastewater and excreta use in agriculture. World Health Organization (WHO), Geneva, Switzerland.
- Blumenthal, U. J., Mara, D. D., Peasey, A., Ruiz-Palacios, G., and Stott, R. (2000a). Guidelines for the microbiological quality of treated wastewater used in agriculture: recommendations for revising WHO guidelines. *Bulletin of the World Health Organization*, 78 (9), pp. 1104 - 1116.
- Blumenthal, U. J., Peasey, A., Ruiz-Palacios, G., and Mara, D. D. (2000b). Guidelines for wastewater reuse in agriculture and aquaculture: recommended revisions based on new research evidence. London School of Hygiene & Tropical Medicine, London, England.
- BMZ (2004). Auf dem Weg zur Halbierung der Armut. - 2. Zwischenbericht über den Stand der Umsetzung des Aktionsprogramms 2015. Bundesministerium für wirtschaftliche Zusammenarbeit und Entwicklung. http://www.bmz.de/de/service/infothek/fach/spezial/spezial088/spezial088_30.html.
- Boehler, M, Joss, A., Buetzer, S., Holzapfel, M., Mooser, H., and Siegrist, H. (2007). Treatment of toilet wastewater for re-use in an MBR. In: *Advanced Sanitation, 12. - 13.03.2007, Aachen, Germany*.
- Braun, U. patent: PCT/EP98/03316.
- Braunisch, F., Friehmelt, V., Schneider-Fresenius, W., and Gidarakos, E. (2005). Verfahren zum Abbau organischer Schadstoffe in Abwasserbehandlungsanlagen. *KA*, 52 (4), pp. 415 - 426.
- Brett, S., Guy, J., Morse, G. K., and Lester, J. N. (1997). *Phosphorus removal and recovery technologies*. Selper Publications, London; Great Britain.

- Breuer, K. (2002). *Vergleich verschiedener chemischer Oxidationsverfahren sowie der Aktivkohleadsorption zur Entfärbung von Gelbwasser*. Diplomarbeit, Hamburg University of Technology (TUHH).
- Brinkmeyer, J., Rosenwinkel, K.-H., Flasche, K., Koppmann, M., and Austermann-Haun, U. (2005). Einsatz und Erfahrungen mit Membranbiologien im ländlichen Raum - Bedeutung und Chancen für die Verwendung in Kleinkläranlagen. *KA*, 52 (2), pp. 158 - 163.
- Brombach, H. (2006). Abwasserkanalisation und Regenbecken im Spiegel der Statistik. *KA*, 53 (11), pp. 1114 - 1122.
- Buchmann, P., Rufli, T., and Hirsig, J. (1998). *Lehrbuch der Proktologie*. Verlag Hans Huber, Bern, Switzerland.
- Bullermann, M., Lücke, F., Mehlhart, G., and Klaus, U. (2001). *Grau- und Regenwassernutzung Kassel-Hasenhecke*. Fachvereinigung Betriebs- und Regenwassernutzung e.V., Darmstadt, Germany.
- Bünning, G. (1995). *Kontinuierliche Wasserdeseinfektion mittels Ozon in Rohrreaktoren*. Dissertation, Universität-GH Paderborn; Fachgebiet Technische Chemie und Chemische Verfahrenstechnik.
- Caspary, W. F. and Stein, J. (1999). *Darmkrankheiten - Klinik, Diagnostik und Therapie*. Springer Verlag, Berlin, Germany.
- Chang, Y., Cornel, P., and Wagner, M. (2007). Treatment of grey water for urban water reuse - a comparison of different techniques. In: *Advanced Sanitation, 12. - 13.03.2007, Aachen, Germany*.
- Clara, M., Strenn, B., Gans, O., Martinez, E., Kreuzinger, N., and Kroiss, H. (2005). Removal of selected pharmaceuticals, fragrances and endocrine disrupting compounds in a membrane bioreactor and conventional wastewater treatment plants. *Water Research*, 2005 (39), pp. 4797 - 4807.
- Coors, A. (2004). *Estrogene Aktivität im Abwasser - Nachweis mit Hilfe eines biologischen Wirktests und Erfassung der Elimination bei weitergehender Abwasserreinigung*. Dissertation, RWTH Aachen.
- Cornel, P. and Krause, S. (2006). Das Membranbelebungsverfahren in der industriellen Abwasserbehandlung - Erfahrungen und Beispiele. *KA*, 53 (10), pp. 1018 - 1024.
- de Graaff, M. S., Zeeman, G., Euverink, G. J. W., and Buisman, C. J. N. (2007). Selection of treatment schemes for concentrated black water. In: *Advanced Sanitation, 12. - 13.03.2007, Aachen, Germany*.
- Dockhorn, T. (2006). Ressourcenökonomische Anreize für ein zukunftsfähiges Stoffstrommanagement in der kommunalen Abwasserwirtschaft. *KA*, 53 (1), pp. 35 - 41.
- Donnert, D. and Salecker, M. (1999). Elimination of phosphorous from wastewater by crystallization. *Environmental Technology*, 20, pp. 735 - 742.

- Döpkins, E. (2004). *Abwasserbehandlung und Prozesswasserrecycling in der Textilveredelungsindustrie*. Dissertation, TU Braunschweig, Institut für Bioverfahrenstechnik.
- Dreier, T. (1999). Ganzheitliche Bilanzierung von Grundstoffen und Halbzeugen. Forschungsstelle für Energiewirtschaft der Gesellschaft für praktische Energiekunde e.V., Munich, Germany.
- Duguet, J.-P., Bruchet, A., and Mallevialle, J. (2004). Pharmaceuticals and endocrine disruptors in the water cycle. *IWA Yearbook*, pp. 41 - 46.
- Eggers, M. (2007). Tender of the company Biesterfeld Chemiedistribution GmbH. Personal communication.
- Eichhorn, U., Bierbaum, R., Wurster, B., Behlke, A., Halbach, M., Friedemann, J., Halbach, U., Möller, C., and Rasch, C. (2003). *Kommunale Abwasserbeseitigung*. Institut für Abwasserwirtschaft Halbach, Werdau, Germany.
- Escher, B. I., Pronk, W., Suter, M. J. F., and Maurer, M. (2006). Monitoring the removal efficiency of pharmaceuticals and hormones in different treatment processes of source-separated urine with bioassays. *Environmental Science & Technology*, 40 (16), pp. 5095 - 5101.
- Falk, D. S., Brill, D. R., and Storck, D. G. (1990). *Ein Blick ins Licht*. Springer Verlag, Berlin, Germany.
- Fricke, K., Bahlke, A.-M., Kehres, B., and Vogtmann, H. (1989). Vermarktung von Kompost. In: *Witzenhäuser Abfalltage, 7. - 9.06.1989, Kassel, Germany*.
- Friedrich, H., Ries, T., and Hannich, C. B. (2005). Kommunale Kläranlagen als Eintragspfad für organische Spurenschadstoffe in die aquatische Umwelt. *KA*, 52 (3), pp. 279 - 291.
- Gajurel, D. R. (2003). *Evaluation of Decentral Physico-Biological Systems for Pre-treatment of Household Wastewater and their Potential for Ecological Sanitation*. Dissertation, Hamburg University of Technology (TUHH).
- Gajurel, D. R., Behrendt, J., Li, Z., and Otterpohl, R. (2004). Investigation on effectiveness of Rottebehälter for pre-treatment of brown water in source control sanitation. In: *IWA/GTZ 2nd international symposium on ecological sanitation, 07. -11.04.2003, Lübeck, Germany*.
- Gajurel, D. R., Shalabi, M., Gulyas, H., Behrendt, J., and Otterpohl, R. (2006). Potential of filter vermicomposters for household wastewater pre-treatment and sludge sanitisation on site. In: *7th IWA specialised conference on small water and wastewater systems, 03.2006, Mexico City, Mexico*.
- Gethke, K., Herbst, H., Montag, D., and Köster, J. (2005a). Abwasserbehandlung - Phosphorressource von morgen? *KA*, 52 (5), pp. 500 - 505.
- Gethke, K., Herbst, H., Montag, D., and Pinnekamp, J. (2005b). Potentiale des Phosphorrecyclings aus Klärschlamm und phosphathaltigen Abfallströmen in Deutschland. *KA*, 52 (10), pp. 1114 - 1119.
- Giesen, A. (1999). Crystallisation process enables environmental friendly phosphate removal at low costs. *Environmental Technology*, 20, pp. 769 - 775.

- Gieske, M., Becker, G., Bönning, T., and Lohse, M. (2005). Untersuchungen zur Phosphorrückgewinnung aus Klärschlamm. *KA*, 52 (4), pp. 431 - 436.
- Goldbach, H. E. (2004). Nährstoffwirkung von Sekundärrohstoffdüngern: Einflussfaktoren und Anforderungen aus der Landwirtschaft. In: *Landwirtschaftliche Verwertung von Klärschlämmen und Bioabfällen - Status Quo und Perspektiven*, Marburg, Germany.
- Gujer, W. (1999). *Siedlungswasserwirtschaft*. Spronger Verlag, Berlin, Germany.
- Gulyas, H. (2003). *Organische Problemstoffe in Abwässern: Wirkungen und Behandlungsverfahren*. Gesellschaft zur Förderung der Forschung und Entwicklung der Umwelttechnologien an der Technischen Universität Hamburg-Harburg e.V. (GFEU an der TUHH), Hamburg, Germany.
- Gulyas, H., Breuer, K., Lindner, B., and Otterpohl, R. (2004). Screening of chemical oxidation processes and other methods for decolorization of urine for its re-use as toilet-flush liquid in ecological sanitation systems. *Water Science and Technology*, 49 (4), pp. 241 - 246.
- Günthert, F. W. and Reicherter, E. (2001). *Investitionskosten der Abwasserentsorgung*. Oldenbourg Industrieverlag, Munich, Germany.
- Guttau, S. (2005). *Beitrag zur Entwicklung, Optimierung und Simulation eines Membranbioreaktors zur Abwasseraufbereitung an Bord von Schiffen*. Dissertation, Hamburg University of Technology (TUHH), Arbeitsbereich Verfahrenstechnischer Apparatebau, Shaker Verlag.
- Hackner, T. (2004). Decentralised Wastewater Treatment with Membrane Technology. In: *DeSa/R-Symposium 2004, Berching, Germany*.
- Hamacher, R. (2000). Bau- und Betriebskosten von Anlagen zur Regenwasserversickerung. *KA*, 47 (4), pp. 560 - 568.
- Hammer, M. (2005). Teilstrombehandlung und -nutzung von Urin im Hinblick auf pharmazeutische Rückstände. In: *Stipendientag der DBU auf der IFAT, Munich, Germany*.
- Hammer, M., Tettenborn, F., Behrendt, J., Gulyas, H., and Otterpohl, R. (2005). Pharmaceutical residues: Database assessment of occurrence in the environment and exemplary treatment processes for urine. In: 1st National Young Researchers Conference in Aachen, Aachen, Germany.
- Hansen, W. E. (1987). *Internistische Gastroenterologie*. Springer Verlag, Berlin, Germany.
- Harms, M. and Englert, R. (2006). Getauchte Membranfiltration in der dezentralen Abwasserreinigung. *KA*, 53 (12), pp. 1246 - 1251.
- Hautmann, R. E. and Huland, H. (1997). *Urologie*. Springer-Verlag, Berlin, Germany.
- Heberer, T., Verstraeten, I. M., Meyer, M. T., Mechlinski, A., and Reddersen, K. (2001). Occurrence and fate of pharmaceuticals during bank filtration - Preliminary results from investigations in Germany and the United States. *Journal of Contemporary Water Research and Education*, 120, pp. 4 - 17.

- Hegemann, W. and Busch, K. (2000). Untersuchungen zum Abbau endokrin wirksamer Substanzen in Kläranlagen. In: *Chemische Stressfaktoren in aquatischen Systemen, Berlin, Germany*.
- Heinonen-Tanski, H. and van Wijk-Sibesma, C. (2005). Human excreta for plant production. *Bioresource Technology*, 96, pp. 403 - 411.
- Herbers, H. (1996). Das Image von Kompost und kompostgedüngten Agrarerzeugnissen beim Verbraucher. In: *2. BMBF-Statusseminar - Neue Techniken zur Kompostierung, 6. - 8.11.1996, Hamburg, Germany*.
- Hillenbrand, T. and Böhm, E. (2004). Kosten-Wirksamkeit von Maßnahmen im Bereich der Regenwasserbehandlung und -bewirtschaftung. *KA*, 51 (8), pp. 837 - 844.
- Hofstetter, A. G. and Eisenberger, F. (1996). *Urologie für die Praxis*. Springer Verlag, Berlin, Germany.
- Houtte, E. v., Verbauwhede, J., Bach, S., and Brockmann, M. (2004). Aufbereitung von gereinigtem Abwasser zu Rohwasser für die Trinkwasserversorgung in Flandern (Belgien). *KA*, 51 (7), pp. 754 - 759.
- Jimenez, B. and Asano, T. (2004). Acknowledge all approaches: the global outlook on reuse. *water* 21 (12), pp. 32 - 37.
- Jocham, D. and Miller, K. (1994). *Praxis der Urologie*. Georg Thieme Verlag, Stuttgart, Germany.
- Jönsson, H. and Vinneras, B. (2004). Adapting the nutrient content of urine and faeces in different countries using FAO and Swedish data. In: *ecosan - closing the loop, 2nd international symposium on ecological sanitation, Luebeck, Germany*.
- Jönsson, H., Stintzing, A. R., Vinneras, B., and Salomon, E. (2004). *Guidelines on the Use of Urine and Faeces in Crop Production*. SEI - Stockholm Environment Institute, Stockholm.
- Kaschka, E., Knoll, G., Berg, U., and Donnert, D. (2005). Anwendung der tobermorit-induzierten Kristallisation zur P-Elimination und P-Rückgewinnung aus kommunalem Abwasser. *KA*, 52 (11), pp. 1236 - 1242.
- Kegebein, J. (2007). Price information by the company 2H Kunststoff GmbH. Personal communication.
- Keil, F. (2006). Medikamentenentsorgung in deutschen Haushalten - Erste repräsentative Umfrage zur Entsorgung von Arzneimitteln. Strategien zum Umgang mit Arzneimittelwirkstoffen im Trinkwasser (start), Institut für sozial-ökologische Forschung (ISOE), Frankfurt am Main, Germany.
- Kipp (2007). Price information by the company Ingenieurbüro Woitzel. Personal communication.
- Klopp, R. (2005). Monitoringkonzepte für die Umsetzung der Europäischen Wasserrahmenrichtlinie / Gefährliche Spurenstoffe in der aquatischen Umwelt - Jahrestagung der Wasserchemischen Gesellschaft. *KA*, 52 (11), pp. 1212 - 1214.
- Kosyna, L. (2007). *Verschiedene Verfahren zur Pharmakabehandlung in Urin - ein Literaturvergleich*. project work, Hamburg University of Technology (TUHH).

- Kötzle, T. (2004). *Rückgewinnung von Trinkwasser aus Filterspülwasser mittels getauchter Membranen*. Technische Universität München, Munich, Germany.
- Krauth, K. and Günder, B. (1999). Neue Erkenntnisse zum Membranbelebungsverfahren. In: *Erfahrungen und neue Entwicklungen in der Abwasserbehandlung, Dresden, Germany*.
- Kroiss, H. (2004). Infiltration of Rainwater and Treated Wastewater Benefits and Challenges. In: *DeSa/R-Symposium 2004, Berching, Germany*.
- Kumar, D., Waldron, D. J., and Williams, N. S. (1991). *Clinical Measurement in Coloproctology*. Springer Verlag, London, England.
- Kümmerer, K. (2000). Abbau von Arzneimitteln in Testsystemen und Möglichkeiten zur Emissionsreduktion. In: *Chemische Stressfaktoren in aquatischen Systemen, Berlin, Germany*.
- Kümmerer, K. (2006). Arzneimittel in Kläranlagen und deren Umweltrelevanz in Gewässern. In: 39. *Essener Tagung für Wasser- und Abfallwirtschaft, 29.03. - 31.03., Essen, Germany*.
- Kunz, D. (2005). *Prozesswasseraufbereitung mittels Umkehrosmose, Ultrafiltration und Nanofiltration unter qualitativen und wirtschaftlichen Aspekten*. Dissertation, Bergische Universität Wuppertal - Fachgebiet Sicherheitstechnik/Umweltschutz.
- Lange, J. and Otterpohl, R. (2000). *Ökologie aktuell - Abwasser*. Mallbeton GmbH, Pfohren, Germany.
- Larsen, T. A. and Lienert, J. (2004). Coping with Micropollutants in Urine-based Fertilizer. In: *DeSa/R-Symposium, 14.07.2004, Berching, Germany*.
- Li, Z. (2004). *Grauwasserbehandlung und -wiederverwendung - Untersuchungen zur höherwertigen Wiederverwendung von Grauwasser in Verbindung mit teilstromorientierten ökologischen Sanitärkonzepten*. Dissertation, Hamburg University of Technology (TUHH) - Institute of Wastewater Management and Water Protection.
- Lindner, B. (2001). *Bau und Inbetriebnahme einer Versuchsanlage zur Eindampfung von Gelbwasser als Technik zur direkten Wertstoffgewinnung in urbanen Gebieten*. Diplom Thesis, Hamburg University of Technology, Institute of Wastewater Management and Water Protection.
- Lindner, B., Tettenborn, F., Gulyas, H., Breuer, K., Mühlenstädt, J., and Otterpohl, R. (2003). Saving water and recovering nutrients by a closed loop system for toilet flushing - pre tests. In: *2nd International Symposium on ecological sanitation, Luebeck, Germany*.
- Lindner, B., Tettenborn, F., Hesemann, K., and Buchholz, A. (2004). Dezentrale Abwasserbeseitigung in Wasserschutzgebieten - Erstellung eines Konzeptes für einen Überwachungskreis und Begehung von rund 40 Grundstücken im WSG Süderelbmarsch / Harburger Berge. Hamburg, Germany.
- Lohmann, T. (2004). *The Process-research of Ureolysis and the Design of an Optimised Ureolysis Reactor*. Master Thesis, Hamburg University of Technology, Institute of Wastewater Treatment and Water Protection.

- Luchterhand, B. (2006). *Pharmakaabbau in Gelbwasser durch Ozonisierung und UVC-Bestrahlung*. Project work, Hamburg University of Technology (TUHH), Institut of wastewater management and water protection.
- Mehlhart, G., Zwerenz, A., Bernhardt, H.-G., Büst, B., Büttner, R., Kimmich, S., Nolde, E., Weber, B., and Zeisel, J. (2005). fbr H 201 - Grauwasser-Recycling. Fachvereinigung Betriebs- und Regenwassernutzung e.V. (fbr).
- Meinzing, F. (2007). Personal communication.
- Mels, A., Telkamp, P., Koetse, E., and Braadbaart, O. (2007). Experiences and preceptance of the users of black and grey water systems in Norway and Germany. In: *Advanced Sanitation*, 12. - 13.03.2007, Aachen, Germany.
- Mobley, H. L. T. and Hausinger, R. P. (1989). Microbial ureases: Significance, regulation, and molecular characterization. *Microbiological Reviews*, 53 (1), pp. 85 - 108.
- Moriyama, K., Kojima, T., Minawa, Y., Matsumoto, S., and Nakamachi, K. (2001). Development of artificial seed crystal for crystallization of calcium phosphate. *Environmental Technology*, 22, pp. 1245 - 1252.
- Oberg, C. (1995). *Desinfektion von biologisch gereinigtem Abwasser mit UV-Licht und Ozon und ihre Nebenwirkungen*. Dissertation, Private Universität Witten/Herdecke GmbH, Lehrstuhl für Umwelttechnik und Management.
- Oldenburg, M. and Dlabacs, C. (2007). SCST-Project - Cost Calculations Report. Kompetenzzentrum Wasser Berlin, Berlin, Germany.
- Orbach, R. (2007). Tender of the company sterilAir GmbH. Personal communication.
- Otterpohl, R. (2000). Zwischen Utopie und Realität: Weg von der anthropogenen Gewässerbelastung. In: *Chemische Stressfaktoren in aquatischen Systemen*, Berlin, Germany.
- Otterpohl, R. (2001a). Perspektiven für neue Abwasserkonzepte mit Blick auf den Weltmarkt. In: *Norddeutsche Tagung für Abwasserwirtschaft und Gewässerschutz*, Lübeck, Germany.
- Otterpohl, R. (2001b). Erste Erfahrungen mit alternativen Abwasserentsorgungsanlagen. In: ISA, RWTH Aachen(ed.), vol 84.
- Otterpohl, R. (2007a). Alternative Konzepte zur Abwasserentsorgung. In: *6. Rostocker Abwassertagung "Planung und Betrieb von Abwasserableitungssystemen"*, 16. - 17.11.2006, Rostock, Germany.
- Otterpohl, R. (2007b). Options for alternative types of sewerage and treatment systems directed to improvement of the overall performance. *Water Science and Technology*, 45 (3), pp. 149 - 158.
- Otterpohl, R. and Oldenburg, M. (2002). Innovative Technologien zur dezentralen Abwasserbehandlung in urbanen Gebieten. *KA*, 49 (10).

- Otterpohl, R., Albold, A., and Oldenburg, M. (1999a). Source Control in Urban Sanitation and Waste Management: 10 Options with Ressource Management for different social and geographical conditions. *Water Science and Technology*, 37.
- Otterpohl, R., Braun, U., and Oldenburg, M. (2002). Innovative Technologies for Decentralised Wasterwater Management in Urban and Peri-Urban Areas. In: *IWA Conference - Small Wastewater Treatment Plants, September 2002, Istanbul, Turkey*.
- Otterpohl, R., Braun, U., and Oldenburg, M. (2004). Innovative Technologies for Decentralised Water-, Wastewater and Biowaste Management in Urban and Peri-Urban Areas. *Water Science and Technology*, 48 (11), pp. 23 - 32.
- Otterpohl, R., Braun, U., Lindner, B., and Behrendt, J. (2007). The loo-loop process for highly efficient stand-alone water systems. In: *Advanced Sanitation, 12. - 13.03.2007, Aachen, Germany*.
- Otterpohl, R., Oldenburg, M., and Büttner, S. (1999b). Alternative Entwässerungskonzepte zum Stoffstrommangement. *KA*, 46 (2).
- Pinnekamp, J. (2003). Phosphor und Siedlungswasserwirtschaft. In: *36.Essener Tagung für Wasser- und Abfallwirtschaft, 26.03. - 28.03., Aachen Germany*.
- Pinnekamp, J., Baumann, P., Buer, T., Cornel, P., Donnert, D., Göttlicher-Schmidle, U., Heinzmann, B., Jardin, N., Londong, J., Müller, J., von Sothen, F., Temmink, H., Berg, U., Christian-Bickelhaupt, R., Schaum, C., Weideler, A., and Wichmann-Seidel, A. (2003). Phosphorrückgewinnung. ATV-DVWK, Hennef, Germany.
- Pronk, W., Biebow, M., and Boller, M. (2006a). Treatment of source-separated urine by a combiation of bipolar electro dialysis and a gas transfer membrane. *Water Science and Technology*, 53 (3), pp. 139 - 146.
- Pronk, W., Biebow, M., and Boller, M. (2006b). Electrodialysis for recovering salts from urine solution containing micropollutants. *Environmental Science & Technology*, 40 (7), pp. 2414 - 2420.
- Pronk, W., Palmquist, H., Biebow, M., and Boller, M. (2006c). Nanofiltration for the separation of pharmaceuticals from nutrients in source-separated urine. *Water Research*, 40, pp. 1405 - 1412.
- Prüss-Üstün, A. and Corvalán, C. (2006). Preventing disease through healthy environments. World Health Organisation (WHO), Geneva, Switzerland.
- Rakelmann, U. V. (2002). Alternative Sanitärkonzepte in Ballungsräumen. In: *12. Europäisches Wasser-, Abwasser und Abfall-Symposium, Munich, Germany*.
- Ridderstolpe, P. (2004). *Introduction to Greywater Management*. SEI, Stockholm Environment Institute, Stockholm, Sweden.
- Rohweder, U. (1998). *Auswirkungen der Anwendung von Clofibrinsäure und anderer Arzneimittel auf die Umwelt und Trinkwasserversorgung*. Freie und Hansestadt Hamburg - Umweltbehörde, Hamburg, Germany.

- Rohweder, U. (2003). *Arzneimittel in der Umwelt - Auswertung der Untersuchungsergebnisse*. Freie und Hansestadt Hamburg - Behörde für Umwelt und Gesundheit, Hamburg, Germany.
- Römer, W. (2006). Vergleichende Untersuchung der Phosphatverfügbarkeit von Produkten des P-Recyclings und bekannter Phosphatdünger. *KA*, 53 (5), pp. 483 - 489.
- Schenker, R., Schulin, R., Stadelmann, F. X., and Sticher, H. (1997). *Bodenökologie*. Georg Thieme Verlag, Stuttgart, Germany.
- Scheytt, T., Heberer, T., and Stan, H.-J. (2000). Vorkommen und Verhalten von Arzneimitteln im Grundwasser. In: *Chemische Stressfaktoren in aquatischen Systemen*, Berlin, Germany.
- Schleypen, P. and Hruschka, H. (2004). Membranbelebung auf der Kläranlage Mohnheim - Leistung, Aufwand, Perspektiven. In: *32. Abwassertechnisches Seminar - Abwasserreinigung ohne Biologie - zur Bedeutung chemisch-physikalischer Reinigungsverfahren*, Munich, Germany.
- Schmidt, R. F. and Thews, G. (2005). *Physiologie des Menschen*. Springer-Verlag, Berlin, Germany.
- Schmitt, T. G. (2007). Siedlungswasserwirtschaft 2030 - Mögliche Entwicklungen und Herausforderungen. *KA*, 54 (8), pp. 798 - 804.
- Schneider, C. (2007a). Neuartige Sanitärsysteme - Workshop des Fachausschusses KA-1 und seiner Arbeitsgruppen. *KA*, 54 (2), pp. 133 - 135.
- Schneider, C. (2007b). Undichte Kanäle (k)ein Risiko - Gemeinschaftstagung von DWA und DECHEMA. *KA*, 54 (1), pp. 16 - 18.
- Schneider, R. J. (2005a). Aufnahme von Pharmaka in Nutzpflanzen nach Urinapplikation aus einem dezentralen Abwasserwertungskonzept. In: *117. VDLUFA-Kongress in Bonn - 27. - 30. September 2005, Bonn, Germany*.
- Schneider, R. J. (2005b). Pharmaka im Urin: Abbau und Versickerung vs. Pflanzenaufnahme. In: *Nährstofftrennung und -verwertung in der Abwassertechnik am Beispiel der "Lambertsmühle"*, Bonn, Germany.
- Schnug, E., Kratz, S., Kley, G., and Adam, C. (2006). EU-gefördertes Projekt zur Nutzung von Nährstoffen aus Klärschlamm. *KA*, 53 (2), pp. 215.
- Schönning, C. (2001). Urine diversion - hygienic risks and microbial guidelines for reuse. World Health Organization (WHO), Geneva, Switzerland.
- Schönning, C. and Stenström, T. A. (2004). *Guidelines for the Safe Use of Urine and Faeces in Ecological Sanitation Systems*. Stockholm Environment Institute, Stockholm.
- Schrader, C., Krampe, J., Kuch, B., and Rott, U. (2006). Elimination hormonell wirksamer Substanzen und Arzneimittel aus dem Abwasser mit weitergehender Verfahrenstechnik. In: *39. Essener Tagung für Wasser- und Abfallwirtschaft, 29.03. - 31.03.2006, Essen, Germany*.
- Schuster, M. (2007). EMAS-Umwelterklärung 2006 der Hamburger Wasserwerke. Hamburg, Germany.

- Seyfried, A. (2002). Bemessung von Membranbioreaktoren kommunaler Kläranlagen. In: 35. Essener Tagung für Wasser- und Abwasserwirtschaft, 20.03. - 22.03.2002, Essen, Germany.
- Shalabi, M. (2006). *Vermicomposting of faecal matter as a component of source control sanitation*. Dissertation, Hamburg University of Technology - Institute of wastewater management and water protection.
- Shalabi, M., Behrendt, J., Gulyas, H., and Otterpohl, R. (2004). Vermikompostierung von Braunwasserschläm - ein kostengünstiger Verfahrensschritt innerhalb eines ökologischen Sanitärkonzepts. In: 16. Kolloquium und Fortbildungskurs zur Abwasserwirtschaft, 07. - 09.09.2004, Hamburg, Germany.
- Shalabi, M., Gulyas, H., Behrendt, J., and Otterpohl, R. (2006). Temperature influence on vermicomposting of separated faecal solids by earthworm *Eisenia fetida*. In: 7th IWA specialised conference on small water and wastewater systems, 03.2006, Mexico City, Mexico.
- Sperfeld, D., Rott, U., Meyer, C., Nolde, E., Dreiseitl, H., Holländer, R., Kaiser, M., Stahl, H., Götsch, E., Oldenburg, M., Hiessl, H., Helmreich, B., König, K. W., and Deltau, G. (2005). *Betriebs- und Regenwassernutzung - Bestandsaufnahme und Zukunftsvision*. Fachvereinigung Betriebs- und Regenwassernutzung e.V. (fbr), Darmstadt, Germany.
- Stratful, I., Brett, S., Scrimshaw, M. B., and Lester, J. N. (1999). Biological phosphorus removal, its role in phosphorus recycling. *Environmental Technology*, 20, pp. 681 - 695.
- Tauchmann, H., Hafkesbrink, J., Nisipeanu, P., Thomzik, M., Bäumer, A., Brauer, A., Clausen, H., Drouet, D., Engel, D., Körkemeyer, K., Rothgang, M., and Schroll, M. (2006). *Innovationen für eine nachhaltige Wasserwirtschaft*. Physika-Verlag, Heidelberg, Germany.
- Ternes, T. A. (1998). Occurrence of drugs in German sewage treatment plants and rivers. *Water Research*, 32 (11), pp. 3245 - 3260.
- Ternes, T. A. (2000). Abbau und Verhalten von Pharmaka in aquatischen Systemen. In: *Chemische Stressfaktoren in aquatischen Systemen*, Berlin, Germany.
- Ternes, T. A., Janex-Habibi, M.-L., Knacker, T., Kreuzinger, N., and Siegrist, H. (2004). Assessment of Technologies for the Removal of Pharmaceuticals and Personal Care Products in Sewage and Drinking Water Facilities to Improve the Indirect Potable Water Reuse.
- Tettenborn, F. (2003). *Entfärbung eines Abwasserteilstroms mittels Ozon und UVC-Strahlung im Vergleich - Ein Baustein im Schwarzwasserkreislauf*. Diplom Thesis, Hamburg University of Technology, Institute of Waste Water Management.
- Tettenborn, F. (2007). Yellow and brown water definition. Personal communication.
- Tettenborn, F., Behrendt, J., and Otterpohl, R. (2006). Exemplary Treatment Processes For Yellow Water - Nutrients and Pharmaceutical Residues. In: 5th IWA World Water Congress, Beijing, China.

- Tettenborn, F., Behrendt, J., and Otterpohl, R. (2007a). Treatment of separate collected urine. Hamburg University of Technology, Institute for Wastewater Management and Water Protection, Hamburg, Germany.
- Tettenborn, F., Behrendt, J., and Otterpohl, R. (2007b). Nutrient Recovery from urine and elimination of pharmaceutical residues. In: *Advanced Sanitation, 12. - 13.03.2007, Aachen, Germany*.
- Thaler, S. (2007). Anthropogene Spurenstoffe im Wasser. *KA, 54 (3)*, pp. 231 - 238.
- Thoma, R. (2005). Instandhaltung von Grundstücksentwässerungsanlagen. *KA, 52 (6)*, pp. 725 - 730.
- Udert, K. M. (2002). *The fate of nitrogen and phosphorus in source-separated urine*. dissertation, Swiss Federal Institute of Technology Zurich.
- Udert, K. M., Fux, C., Münster, M., Larsen, T. A., Siegrist, H., and Gujer, W. (2003a). Nitrification and autotrophic denitrification of source-separated urine. *Water Science and Technology, 48 (1)*, pp. 119 - 130.
- Udert, K. M., Larsen, T. A., and Gujer, W. (2003c). Estimating the precipitation potential in urine-collecting systems. *Water Research, 37*, pp. 2667 - 2677.
- Udert, K. M., Larsen, T. A., Biebow, M., and Gujer, W. (2003b). Urea hydrolysis and precipitation dynamics in a urine-collecting system. *Water Research, 37*, pp. 2571 - 2582.
- Ueno, Y. and Fujii, M. (2001). Three years experience of operating and selling recovered struvite from full-scale plant. *Environmental Technology, 22*, pp. 1373 - 1381.
- von Wolffersdorf, S. (2004). *Untersuchung zu Sortiertoiletten unter besonderer Berücksichtigung der Urinverwertung*. diploma thesis, Universität Rostock - Institut für Umweltingenieurwesen.
- Wagner, M. and Henkel, J. (2006). Rückgewinnung von Phosphor aus Abwasser und Klärschlamm. *KA, 53 (4)*, pp. 336 - 338.
- Walthemath, S. (2007). Tender of the company Dr. Paul Lohmann GmbH KG. Personal communication.
- Wedi, D. (2006). Energiebedarf und Wirtschaftlichkeit des Membranbelebungsverfahrens. In: *Membrantage 2005, 21. - 23.06.2005, Osnabrück, Germany*.
- Weinfurtner, K., Wieseler, S., and Wulff, J. (2005). Wirkung von Klärschlamm und Klärschlammmaschen auf Ertrag und Kenngrößen der P-Versorgung. In: *117.VDLUFA-Kongress in Bonn - 27. - 30. September 2005, Bonn, Germany*.
- Weinrich, L. (2007). Tender of the company A3 water solutions GmbH. Personal communication.
- Welker, A. (2005). *Schadstoffströme im urbanen Wasserkreislauf - Aufkommen und Verteilung, insbesondere in den Abwasserentsorgungssystemen*. Habilitation, Technische Universität Kaiserslautern.
- Welsch, N. and Liebmann, C. C. (2003). *Farben - Natur, Technik, Kunst*. Spektrum Akademischer Verlag, Heidelberg, Germany.

- Wendland, C. and Otterpohl, R. (2007). Anaerobic digestion of blackwater and kitchen refuse in a semi-central sanitation concept. In: *Advanced Sanitation, 11. - 12.03.2007, Aachen, Germany*.
- Wendler, D. (2005). *Erfassung und Behandlung von Stoffströmen in der Siedlungswasserwirtschaft*. Dissertation, Universität Hannover.
- Wendler, D., Weichgrebe, D., and Rosenwinkel, K.-H. (2004). Kommunale Stoffströme - Wie sinnvoll ist die getrennte Behandlung von Abwasser und Abfall? In: *16. Fachtagung - Norddeutsche Tagung für Abwasserwirtschaft und Gewässerschutz, Luebeck, Germany*.
- Werner, C. and Bracken, P. (2004). Ecological Sanitation - Respecting the Needs of Developing and Emerging Countries. In: *DeSa/R-Symposium 2004, Berching, Germany*.
- Werner, C., Klingel, F., Mang, H.-P., and Panesar, A. (2005). Bieten neue Sanitärkonzepte verbesserte Exportchancen für die deutsche Wirtschaft? *KA, 52 (2)*, pp. 146 - 152.
- Wetterauer, U., Rutishauser, G., and Sommerkamp, H. (1995). *Urologie*. de Gruyter, Berlin, Germany.
- Wriege-Bechtold, A., Barjenbruch, M., and Wolfferdorf, S. v. (2004). Beispiel eines modernen Sanitärkonzepts in einem Universitätsgebäude. In: *5. Rostocker Abwassertagung - "Dezentrale Abwasserentsorgung", Rostock, Germany*.
- Zernot, I. (2007a). Tender of the company Zernott & Partner Verfahrenstechnik GmbH. Personal communication.
- Zernot, I. (2007b). Tender of the company Zernott & Partner Verfahrenstechnik GmbH. Personal communication.
- Zorn, W. and Kießling, G. (2005). Wirkung des P-Fällungsverfahrens in der Abwasserreinigung auf die P-Sorption im Boden nach Klärschlammdüngung. In: *117. VDLUFA-Kongress in Bonn - 27. - 30. September 2005, Bonn, Germany*.
- Zweynert, U., Sieker, H., Hagendorf, U., Kirschbaum, B., and Wunderlich, D. (2007). Die dezentrale Regenwasserbewirtschaftung ist Stand der Technik - Zwölf Jahre Erfahrungen mit einem großen dezentralen System in schwierigem Gelände. *KA, 54 (9)*, pp. 883 - 886.

13 List of Catchwords

Catchword	Page(s)
Brown water.....	4, 8f, 10, 12, 17, 83
Colour.....	XIII, 1, 3, 4, 5, 7ff, 12, 14ff, 30, 31, 33ff, 49, 55, 58, 61ff, 71ff, 117ff, 120, 139
Decolourisation	12, 14, 17, 34ff, 46f, 49, 55, 61ff, 71, 72ff, 78, 117ff, 120
Deposition.....	14, 33f, 49, 50, 66
Disinfection	35, 55, 61, 78, 82
Endocrine	11f, 61
End-of-pipe.....	2, 19ff, 84, 88ff, 92ff, 101, 107, 114, 119, 146
Fixed bed, fixed biomass	XIII, 31f, 45, 51, 56, 58, 71, 74ff
Green water	14
Grey water.....	XIII, 1f, 10, 13, 14, 20, 24, 27f, 70f, 78, 81ff, 117f, 120, 142ff, 154ff
Grey water loop.....	XIII, 2, 14, 20, 27f, 70f, 81ff, 117f, 120, 154ff
Hygiene.....	5, 9, 12, 19, 22, 24ff, 55, 65, 67, 71, 73, 117f
Costs.....	1f, 14, 20, 23f, 26, 33, 60, 70, 71, 75, 78, 82f, 84ff, 119, 120, 142ff
MBR.....	XIII, 11, 50, 55f, 75ff
Membrane.....	XIII, 5f, 11, 35, 38, 40, 45, 48, 50, 55ff, 61, 65, 67, 71, 72ff, 120, 145ff
Micro pollutant.....	4, 10ff, 22, 25, 61, 78, 89, 118
Nanofiltration.....	11, 67, 72ff, 78f, 119, 120
Nitrification.....	4, 11, 31, 53, 59f, 71, 72, 75, 77, 117
Nutrients.....	1, 6, 10, 12, 13, 19, 20ff, 45, 53f, 70, 89, 91, 117
Odour.....	3, 5, 8, 31, 33f, 38, 40f, 46f, 49, 51f, 55, 58, 61, 66, 117
Ozone.....	4, 11, 17, 22, 27, 34ff, 40ff, 46f, 55, 61ff, 73f, 79, 117ff, 138ff
Rain water/white water.....	1, 14, 19f, 24, 81f, 88
Solid separation.....	3, 14, 30, 49, 50f, 53, 71, 72, 75, 77, 82, 88
Spectrum.....	15ff, 73
Ultrafiltration.....	11, 35, 55, 61, 73, 78, 118, 145ff
Urine/yellow water.....	4ff, 8, 10ff, 17f, 21f, 24, 31, 33ff, 38, 40ff, 45ff, 49, 53, 56ff, 71, 76, 78, 81, 83, 117f, 137
UV.....	XIII, 4, 11, 17, 22, 27, 30, 34ff, 46f, 48, 55, 61ff, 71, 73, 78, 117f, 137f, 145ff
Wavelength.....	XIV, 15ff, 30, 34ff, 73, 117
White water/rain water.....	1, 14, 19f, 24, 81f, 88
Yellow water/urine.....	4ff, 8, 10ff, 17f, 21f, 24, 31, 33ff, 38, 40ff, 45ff, 49, 53, 56ff, 71, 76, 78, 81, 83, 117f, 137

14 Appendix

14.1 Data of Laboratory Scale Experiments

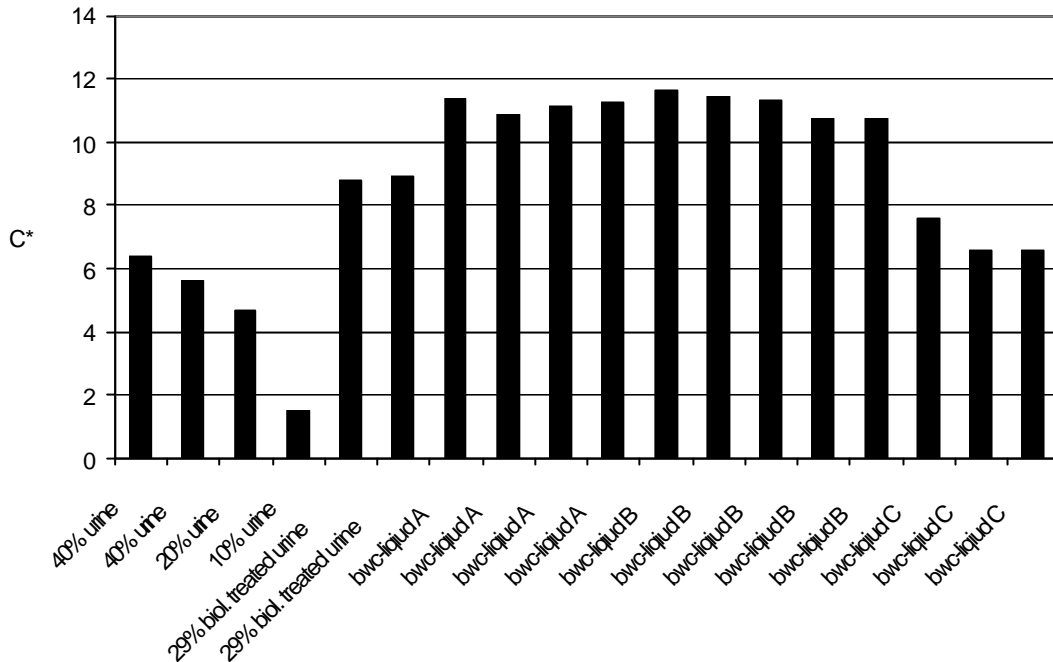

Figure 14-1: C* values of investigated samples at beginning of UV treatment

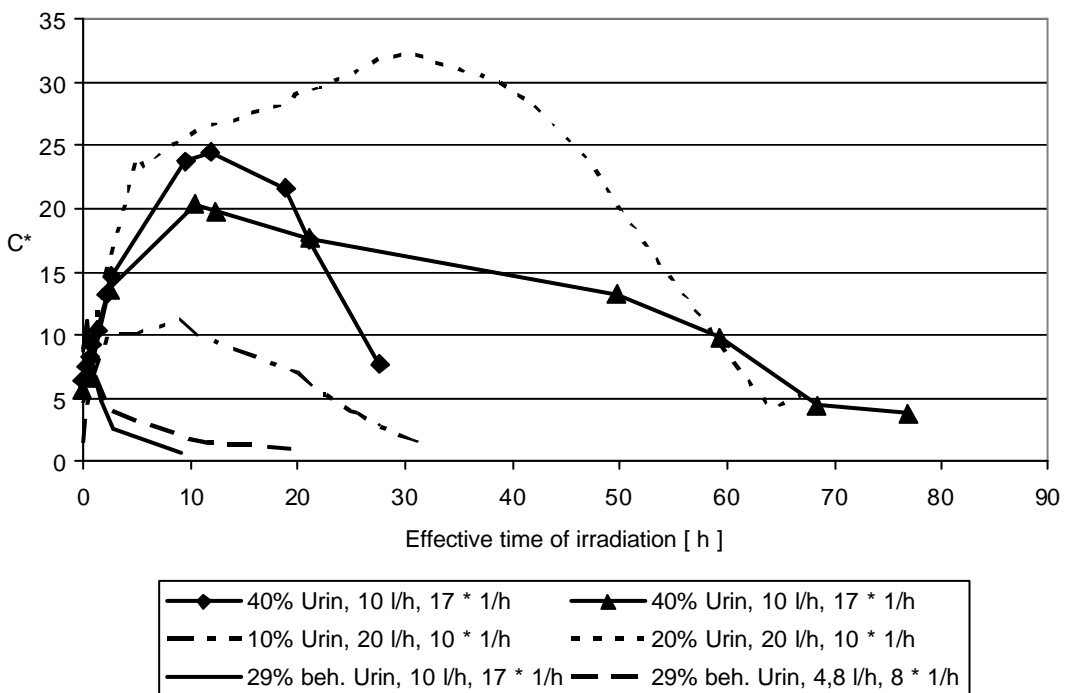

Figure 14-2: C* values of urine samples during UV-treatment with given pump velocity and rate of recirculation

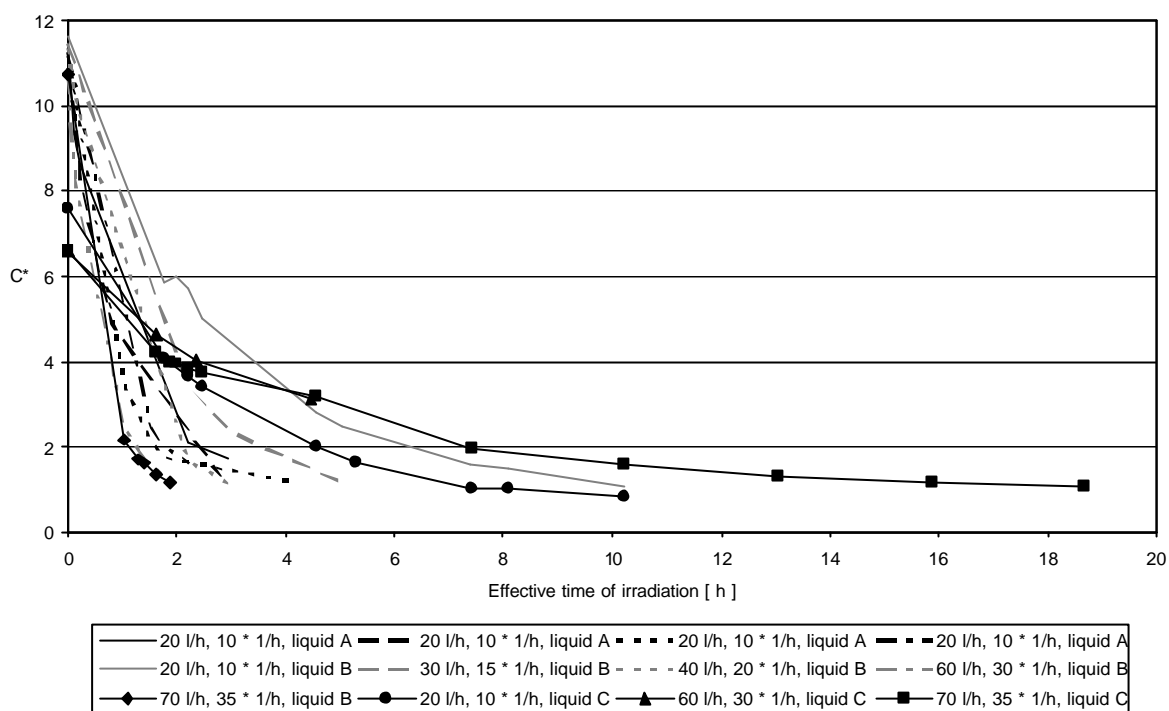

Figure 14-3: C* values of samples from black water loop during UV-treatment with given pump velocity and rate of recirculation

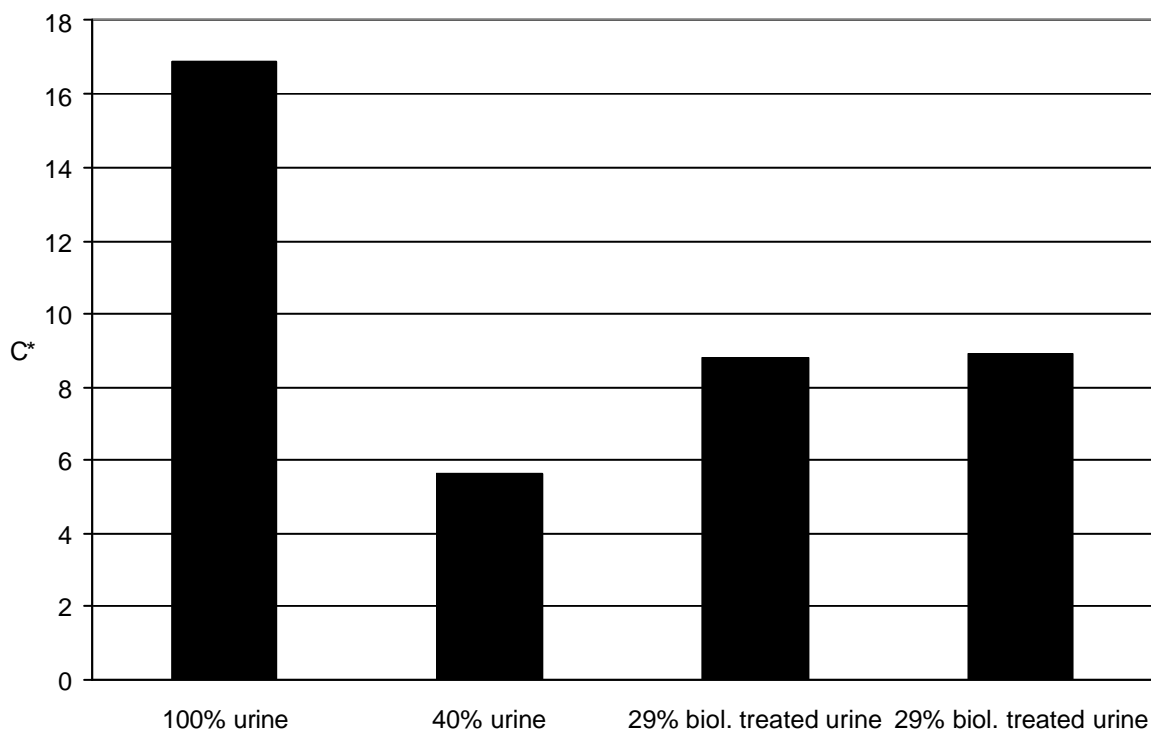

Figure 14-4: C* values of investigated samples at beginning of ozone treatment

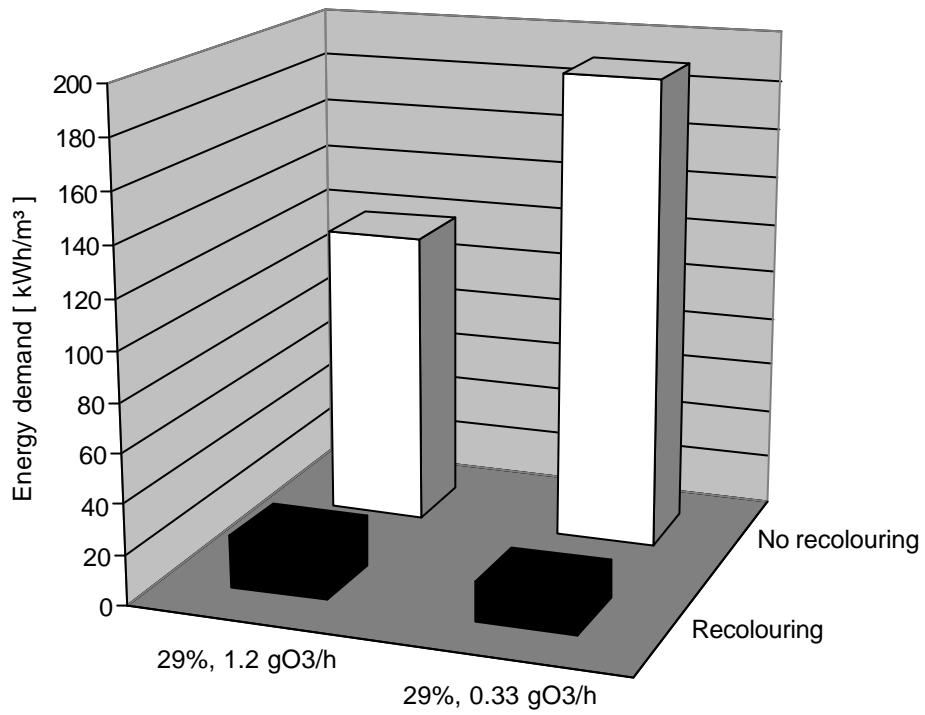

Figure 14-5: For ozonation necessary energy input for colourless status of biologically pre-treated liquids

14.2 Design Values

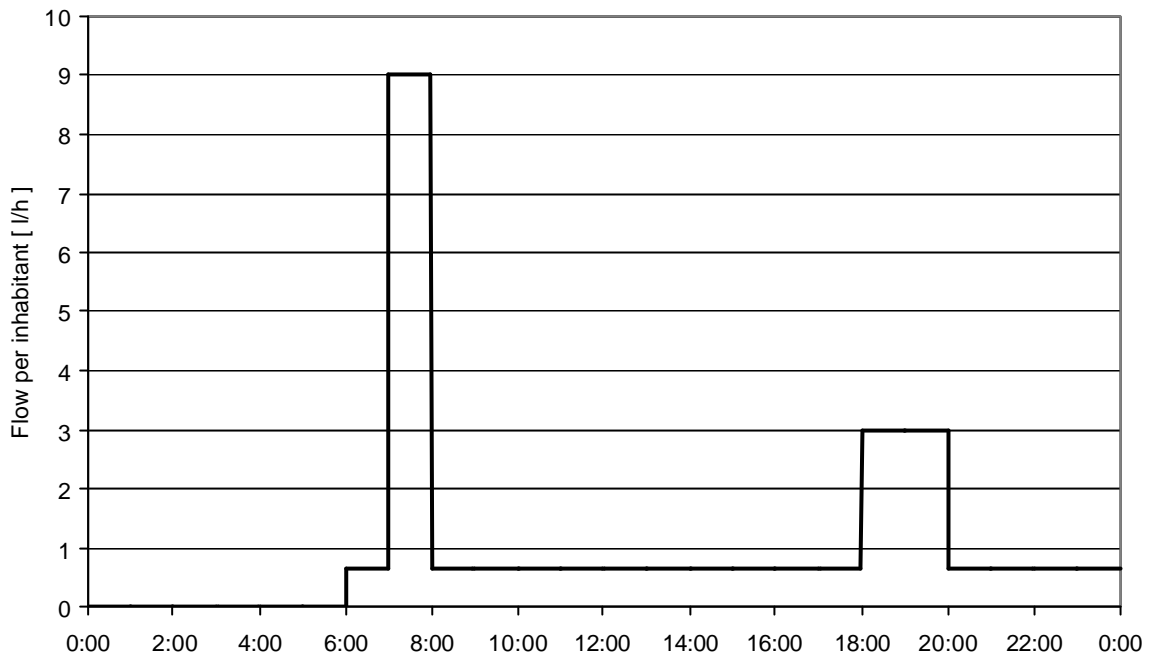

Figure 14-6: Amount curve estimation for black water for a residential building, supposition: the complete daily black water disposal takes place in the house, 25 l/inhabitant*d

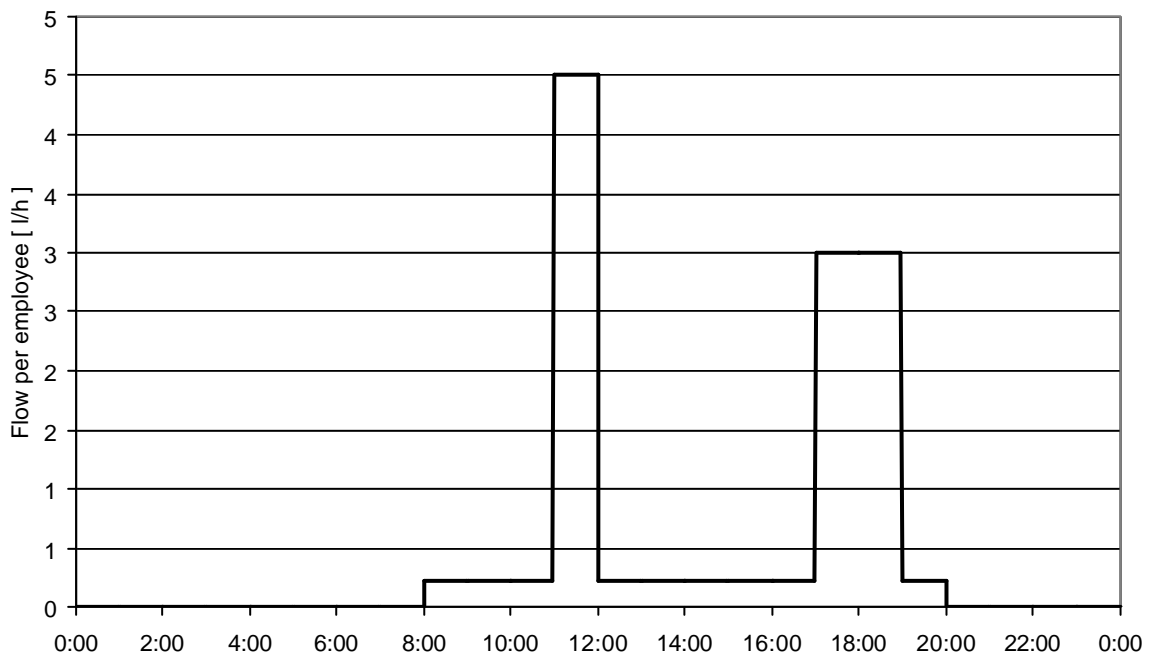

Figure 14-7: Amount curve estimation for black water for an office building, supposition: 2 employees count as one full inhabitants equivalent [Arbeitsblatt ATV-A 122, 1991], 12.5 l/employee*d

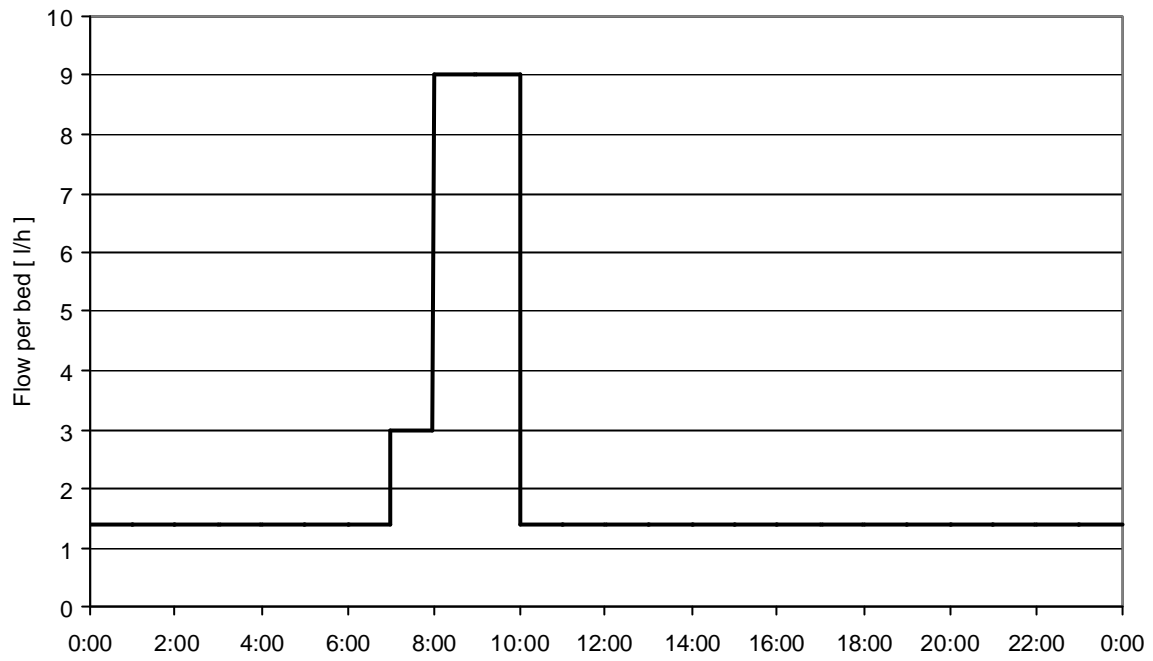

Figure 14-8: Amount curve estimation for black water for a hotel derived from [fbr H 201 - Grauwasser-Recycling, 2005], supposition: 1 bed counts as an equivalent of two full inhabitants [Arbeitsblatt ATV-A 122, 1991], 50 l/bed*d

14.3 Data of Cost Comparison Analysis

Table 14-1: Assumed grey water generation in the hotel, the residential respective the office building

Residential building	Total demand	Time slice	Percentage	Fraction	Average flow
	[l/inhabitant*d]	[hh:mm]	[%]	[l/inhabitant*d]	[l/inhabitant*h]
Showering, bathing...	40	04:00 - 09:00	70	28.00	5.60
		09:00 - 17:00	5	2.00	0.25
		17:00 - 20:00	20	8.00	2.67
		20:00 - 04:00	5	2.00	0.25
Kitchen	12	12:00 - 14:00	30	3.60	1.80
		17:00 - 21:00	70	8.40	2.10
Cleaning	5	08:00 - 20:00	100	5.00	0.42
Washing machine	13	09:00 - 17:00	50	6.50	0.81
		17:00 - 20:00	50	6.50	2.17
Office building					
Office building	Total demand	Time slice	Percentage	Fraction	Average flow
	[l/employee*d]	[hh:mm]	[%]	[l/employee*d]	[l/employee*h]
Showering, bathing...	0	00:00 - 24:00	100	0.00	0.00
Kitchen	15	08:00 - 22:00	40	6.00	0.43
		09:00 - 10:00	20	3.00	3.00
		12:00 - 14:00	40	6.00	3.00
Cleaning	15	06:00 - 14:00	100	15.00	1.88
Washing machine	0	00:00 - 24:00	100	0.00	0.00
Irrigation	5	09:00 - 19:00	100	5.00	0.50
Hotel					
Hotel	Total demand	Time slice	Percentage	Fraction	Average flow
	[l/bed*d]	[hh:mm]	[%]	[l/bed*d]	[l/bed*h]
Showering, bathing...	66	00:00 - 24:00	20	13.20	0.55
		06:00 - 09:00	40	26.40	8.80
		11:00 - 12:00	20	13.20	13.20
		18:00 - 20:00	20	13.20	6.60
Kitchen	18	05:00 - 10:00	20	3.60	0.72
		11:00 - 22:00	80	14.40	1.31
Cleaning	15	09:00 - 22:00	50	7.50	0.58
		12:00 - 14:00	50	7.50	3.75
Washing machine	26	07:00 - 20:00	100	26.00	2.00
Irrigation	15	09:00 - 17:00	100	15.00	1.88

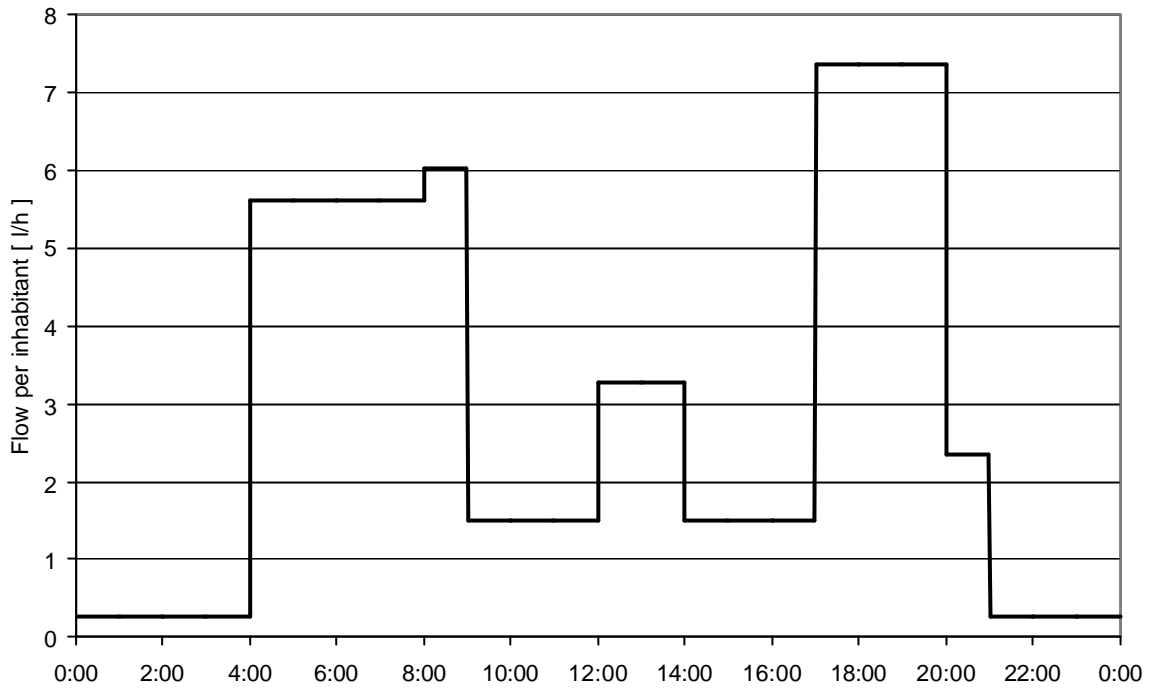

Figure 14-9: Amount curve estimation for the grey water stream for a residential building, supposition: The daily grey water generation is about 70 l/inhabitant, see table 9-5

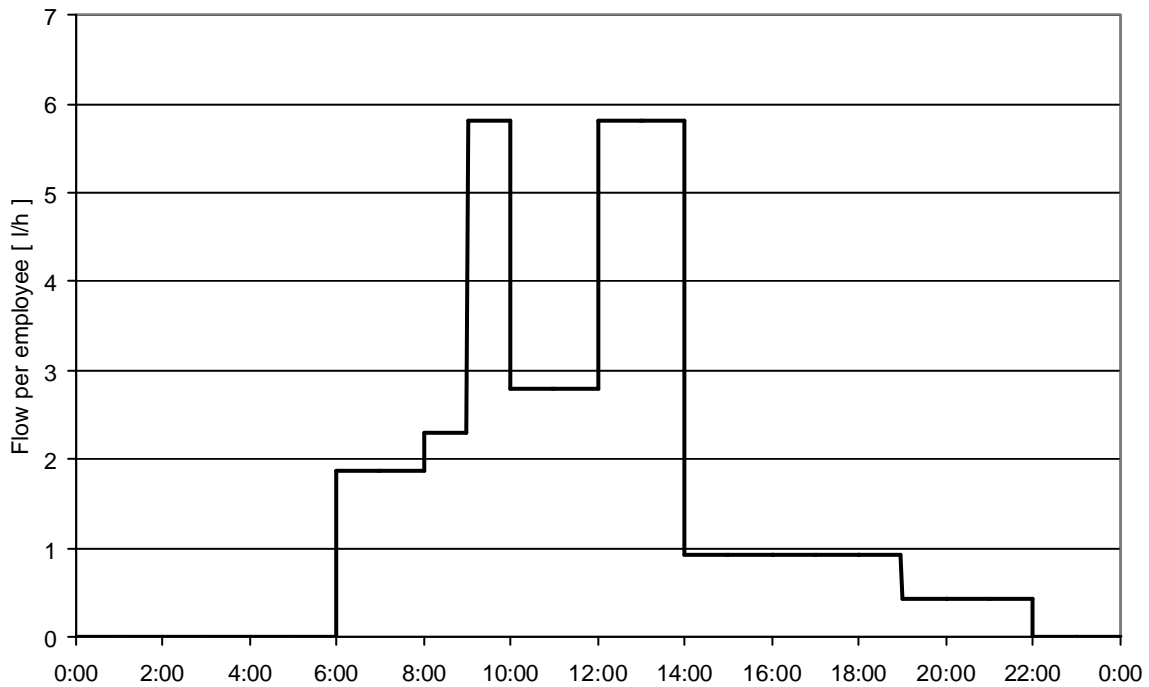

Figure 14-10: Amount curve estimation for the grey water stream for an office building, supposition: 2 employees count as one full inhabitants equivalent [Arbeitsblatt ATV-A 122, 1991], the daily grey water generation is about 35 l/employee, see table 9-5

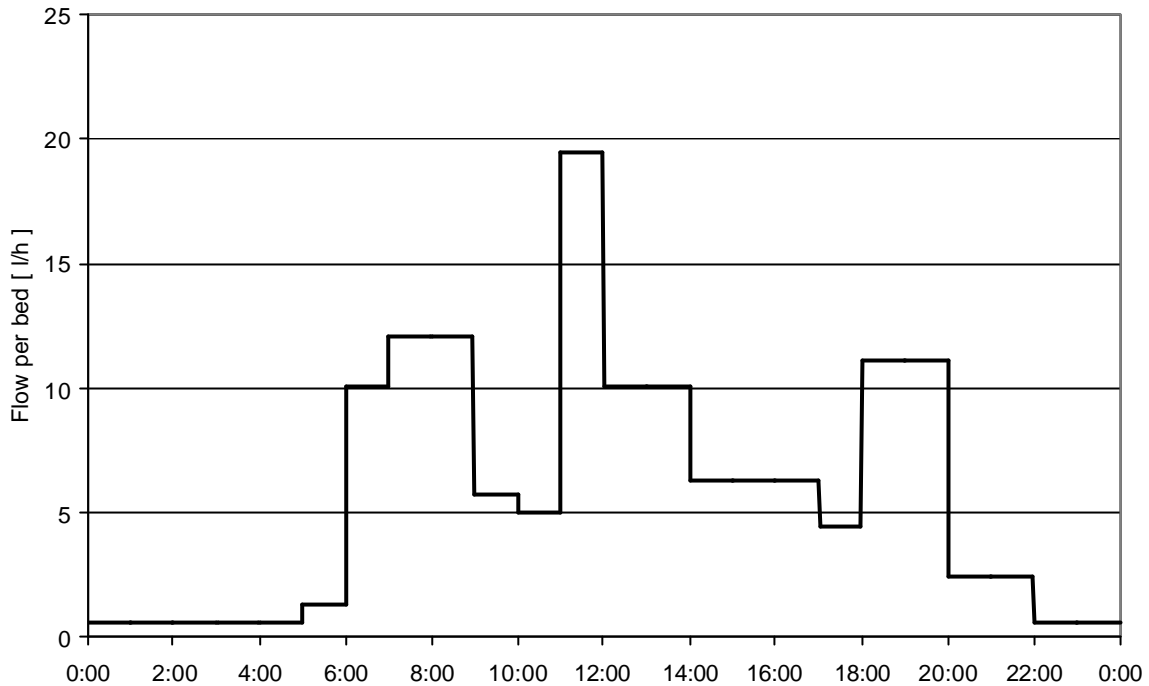

Figure 14-11: Amount curve estimation for the grey water stream for a hotel, supposition: 1 bed counts as an equivalent of two full inhabitants [Arbeitsblatt ATV-A 122, 1991], the daily grey water generation is about 140 l/bed, see table 9-5

Table 14-2: Specific size of volume regulation tanks for grey water

Type of building	Specific volume
Residential	19.2 [l/inhabitant]
Office	17.4 [l/employee]
Hotel	38.5 [l/bed]

Table 14-3: Fertilizer and compost prices and energy demand for production

[3]: [Dockhorn, T., 2006], [6]: [Dreier, T., 1999], [18]: [Oldenburg, M. and Dlabacs, C., 2007], [19]: [Fricke, K. et al., 1989]

Substance	Price [€ / kg substance]	Energy demand for production [kWh/kg]	Source
N-fertilizer	0.706	9.6	[3]
P-fertilizer	0.782	4.86	[3], [6]
K-fertilizer	0.297	2.42	[3], [6]
Compost	0.086	0.11	[18], [19]

Table 14-4: Expected operating periods for selected components

[9]: [Leitlinien zur Durchführung dynamischer Kostenvergleichsrechnungen (KVR-Leitlinien), 1998],
 [10]: [Hillenbrand, T. and Böhm, E., 2004], [11]: [Sperfeld, D., et al., 2005], [12]:
 [Abwasserreinigung mit Membrantechnik, 2003], [13]: [Back, E. et al., 2005], [14]: [Hamacher, R.,
 2000], [15]: [Homepage of the company sterilAir, 2007], [16]: [Oberg, C., 1995], [17]: [Ultraviolet
 disinfection, 1999], [18]: [Oldenburg, M. and Dlabacs, C., 2007]

Element	Expected operating period used in calculations	Found range of values in literature	Sources
	[a]	[a]	
Constructional elements			
Filter material of ground passage	25	25	[10]
Non-pressurized tubes	50	50	[10]
Pressurized tubes	50	40 - 60	[9], [25]
Sand filtration	10	8 - 12	[9]
Sealing of ground passage	50	50	[10]
Soil infiltration	25	15 - 50	[9], [10], [14]
Tanks	50	40 - 60	[9], [10]
Well (construction part)	50	40 - 70	[9], [18], [25]
Technical equipment			
Aeration membrane	10	5 - 10	[12], [13]
Chemical feeder	12.5	12.5 - 17	[9], [18]
Compressor	12.5	12 - 20	[9]
Control unit	12.5	8 - 30	[9], [25]
Filter bag	5		
Fixed bed material	25	15 - 25	[9], [25]
Grease trap	10	8 - 12	[9]
Lab equipment	12.5	10 - 20	[9]
Mechanical foam destruction	12.5	12.5 - 15	[10], [18]
Nanofiltration membrane	5	5 - 10	[12], [13]
Ozone generator	12.5	12.5 - 15	[10], [18]
Pressure control system	12.5	12.5 - 15	[10], [18]
Pumps (intermittent usage)	12.5	8 - 15	[9], [10], [11], [18]
Pumps (permanent usage)	10	8 - 15	[9], [10], [11]
Reverse osmosis membrane	5	5 - 10	[12], [13]
Sensors of control unit	12.5	8 - 30	[9], [25]
Sieve	12.5	10 - 15	[9], [10]
Ultrafiltration membrane	5	5 - 10	[12], [13]
UV emitter	1	1 - 1.5	[15], [16]
UV reactor	10	10	[17]
Valves (automatic)	12.5	12.5 - 16	[10], [18]
Valves (manual)	12.5	12.5 - 15	[10], [18]
Well (technical part)	12.5	12.5 - 15	[10], [18]

Table 14-5: Cost comparison of possible chemicals for addition in the precipitation unit (precipitation/crystallisation and pH regulation)

[7]: [Eggers, M., 2007], [8]: [Walthemath, S., 2007]

Substance		Price per mol [Cent/mol]	Source
Potassium hydroxide	KOH	6.28	[7]
Sodium hydroxide	NaOH	3.47	[7]
Calcium hydroxide	CaH ₂ O ₂	2.82	[7]
Magnesium oxide	MgO	27.51	[8]
Magnesium hydroxide	Mg(OH) ₂	43.49	[8]

Table 14-6: Invest and operating costs of calculated elements of the end-of-pipe system

[5]: [Wissenschaftliche Tabellen Geigy, 1977], [18]: [Oldenburg, M. and Dlabacs, C., 2007],

[42]: [Homepage of the company Hamburg Wasser - Fees, prices, 2007]

Element	Sizing	Investment/ reinvestment costs	Operating costs	Energy demand	Sources
Sewer connection	Estimation of front legh: 300 m	3,875 € + 360 €/m front legh + 50 € = 111,925 €	Cleaning of sewer included in waste water fees	-	[42]
Fertilizer production	For amount and concentrations see table 9-5	-	See table 14-3	See table 14-3	table 9-5, table 14-3
Compost production	34 g/bed*d, 2.000 beds, M _{Hotel} = 68 kg/d; 34 g/p*d, 2.000 inhabitants, M _{Resid} = 68 kg/d; 17 g/empl*d, 2.000 employees, M _{Office} = 34 kg/d	-	See table 14-3	See table 14-3	[5], chapter 8.2, table 14-3
House service connection (waste water), selected length: 50 m	DN 400, material: stoneware pipe	757.73 €/m (including work); 37,886.50 €	Cleaning: 1.3 €/m*a; 65 €/a	-	[18]

Table 14-7: Invest and operating costs of calculated elements of the black water loop system (part 1)

[5]: [Wissenschaftliche Tabellen Geigy, 1977], [18]: [Oldenburg, M. and Dlabacs, C., 2007],
 [27]: [Eichhorn, U., et al., 2003], [28]: [Meinzinger, F., 2007], [29]: [Zernot, I., 2007a],
 [35]: [Wedi, D., 2006], [40]: [Price information of the company Jung Pumpen, 2007],
 [41]: [Price information of the company Albert Block GmbH, 2007]

Element	Sizing	Investment/ reinvestment costs	Operating costs	Energy demand	Sources
Spill over tank	50 l/bed, 2.000 beds, $V_{\text{Hotel}} = 100 \text{ m}^3$; 25 l/inhabitant, 2.000 inhabitants, $V_{\text{Resid}} = 50 \text{ m}^3$; 12.5 l/employee, 2.000 employees, $V_{\text{Office}} = 25 \text{ m}^3$	Hotel: 42,000 €; Residential building: 27,500 €; Office building: 17,800 €	-	-	[18], [27], chapter 8.2
Valve 1	DN 100	310 €	3% of investment per year: 16 €/a	-	[28], [41]
Pump 1	50 l/bed*d, 2.000 beds, $Q_{\text{Hotel}} = 100 \text{ m}^3/\text{d}$ $= 4.2 \text{ m}^3/\text{h}$; 25 l/inhabitant*d, 2.000 inhabitants, $Q_{\text{Resid}} = 50 \text{ m}^3/\text{d}$ $= 2.1 \text{ m}^3/\text{h}$; 12.5 l/employee*d, 2.000 employees, $Q_{\text{Office}} = 25 \text{ m}^3/\text{d}$ $= 1 \text{ m}^3/\text{h}$	Hotel: 305 €; Residential building: 305 €; Office building: 305 €	5% of investment per year: Hotel: 15 €/a; Residential building: 15 €/a; Office building: 15 €/a	0.015 kW/m ³ , estimation: just in use for 200 m ³ /a, 3 kWh/a	[28], [35], [40] chapter 8.2
Sieving unit	$Q_{\text{Hotel}} = 100 \text{ m}^3/\text{d}$; $Q_{\text{Resid}} = 50 \text{ m}^3/\text{d}$; $Q_{\text{Office}} = 25 \text{ m}^3/\text{d}$	Hotel: 7941 €; Residential building: 5650 €; Office building: 4020 €	3% of investment per year: Hotel: 238 €/a Residential building: 170 €/a Office building: 121 €/a	0.25 kW, 2,190 kWh/a	[27], [28], [29], chapter 8.2
Container for solids	34 g/bed*d, 2.000 beds, $M_{\text{Hotel}} = 68 \text{ kg}/\text{d}$; 34 g/p*d, 2.000 inhabitants, $M_{\text{Resid}} = 68 \text{ kg}/\text{d}$; 17 g/empl*d, 2.000 employees, $M_{\text{Office}} = 34 \text{ kg}/\text{d}$	500 €	-	-	[5], chapter 8.2

Table 14-8: Invest and operating costs of calculated elements of the black water loop system (part 2)

[18]: [Oldenburg, M. and Dlabacs, C., 2007], [21]: [Kegebein, J., 2007], [27]: [Eichhorn, U., et al., 2003], [28]: [Meinzinger, F., 2007], [35]: [Wedi, D., 2006], [40]: [Price information of the company Jung Pumpen, 2007], [41]: [Price information of the company Albert Block GmbH, 2007], [45]: [Kipp, 2007]

Element	Sizing	Investment/ reinvestment costs	Operating costs	Energy demand	Sources
Fixed bed material ureolysis	$A_{\text{fixed bed}} = 500 \text{ m}^2$; $V_{\text{fixed bed}} = 3.3 \text{ m}^3$	100 €/m ³ ; 330 €	-	-	[21]
Tank ureolysis	$V_{\text{fixed bed}} = 3.3 \text{ m}^3$; 14.8 l/bed, 2.000 beds, $V_{\text{Hotel}} = 35.5 \text{ m}^3$; 8.1 l/inhabitant, 2.000 inhabitants, $V_{\text{Resid}} = 19.4 \text{ m}^3$; 7.4 l/employee, 2.000 employees, $V_{\text{Office}} = 17.8 \text{ m}^3$	Hotel: 22,000 €; Residential building: 15,000 €; Office building: 14,500 €	-	-	[18], [27], chapter 8.2
Chemical feeder	-	5,175 €	3% of investment per year: 155.25 €/a	neglectable	[28], [45]
Valve 2	DN 50	515 €	3% of investment per year: 15 €/a	-	[28], [41]
Geotextile filter bag	-	150 €	-	-	
Valve 3	DN 50	115 €	3% of investment per year: 3 €/a	-	[28], [41]
Pump 2	$Q_{\text{Hotel}} = 100 \text{ m}^3/\text{d}$ + 20% retentate = 120 m ³ /d = 5 m ³ /h; $Q_{\text{Resid}} = 50 \text{ m}^3/\text{d}$ + 20% retentate = 60 m ³ /d = 2.5 m ³ /h; $Q_{\text{Office}} = 25 \text{ m}^3/\text{d}$ + 20% retentate = 30 m ³ /d = 1.25 m ³ /h	Hotel: 305 €; Residential building: 305 €; Office building: 305 €	5% of investment per year: Hotel: 15 €/a; Residential building: 15 €/a; Office building: 15 €/a	0.015 kW/m ³ , Hotel: 657 kWh/a; Residential building: 329 kWh/a; Office building: 164 kWh/a	[28], [35], [40], chapter 8.2
Tank for biological treatment	$V_{\text{Hotel}} = 150 \text{ m}^3$; $V_{\text{Resid}} = 150 \text{ m}^3$; $V_{\text{Office}} = 75 \text{ m}^3$	Hotel, residential building: 54,000 €; Office building: 35,000 €	-	-	[18], [27], chapter 8.2

Table 14-9: Invest and operating costs of calculated elements of the black water loop system (part 3)

[12]: [Abwasserreinigung mit Membrantechnik, 2003], [21]: [Kegebein, J., 2007], [28]: [Meinzinger, F., 2007], [34]: [Bischof, F. and Paris, S., 2007], [37]: [Günther, F. W. and Reicherter, E., 2001]

Element	Sizing	Investment/ reinvestment costs	Operating costs	Energy demand	Sources
Fixed bed material biological treatment	10.6 m ² /bed, 2.000 beds, V _{fixed bed, hotel} = 141.3 m ³ ; 10.6 m ² /inhabitant, 2.000 inhabitants, V _{fixed bed, resid} = 141.3 m ³ ; 5.3 m ² /employee, 2.000 employees, V _{fixed bed, office} = 70.7 m ³	100 €/m ³ ; Hotel: 17,011 €; Residential building: 17,011 €; Office building: 8,512 €	-	-	[21], chapter 8.2
Aeration (fine bubble, including compressor)	6.43 g O ₂ /(h*bed), 2.000 beds Q _{O₂,Hotel} = 12.86 kg O ₂ /h; 6.43 g O ₂ /(h*p), 2.000 inhabitants Q _{O₂,Resid} = 12.86 kg O ₂ /h; 3.22 g O ₂ /(h*employee), 2.000 employees Q _{O₂,Office} = 6.44 kg O ₂ /h	Hotel: 14,447 €; Residential building: 7,223 €; Office building: 3,612 €	5% of investment per year: Hotel: 722 €/a; Residential building: 361 €/a; Office building: 181 €/a	2.2 kg O ₂ /kWh, Hotel: 51,206 kWh/a; Residential building: 51,206 kWh/a; Office Building: 25,643 kWh/a	[28], [34], [37], chapter 8.2
Aeration (cross flow, including compressor etc.)	A _{Hotel} = 200 m ² ; A _{Resid} = 100 m ² ; A _{Office} = 50 m ²	Investment included in costs for membrane, Reinvestment: Hotel: 4,747 €; Residential building: 2,374 €; Office building: 1,187 €	5% of investment per year: Hotel: 237 €/a; Residential building: 119 €/a; Office building: 59 €/a	10 W/m ² ; Hotel: 17,520 kWh/a; Residential building: 8,760 kWh/a; Office building: 4,380 kWh/a	[12], [28]

Table 14-10: Invest and operating costs of calculated elements of the black water loop system (part 4)

[12]: [Abwasserreinigung mit Membrantechnik, 2003], [18]: [Oldenburg, M. and Dlabacs, C., 2007], [27]: [Eichhorn, U., et al., 2003], [28]: [Meinzinger, F., 2007], [33]: [Cornel, P. and Krause, S., 2006], [40]: [Price information of the company Jung Pumpen, 2007], [41]: [Price information of the company Albert Block GmbH, 2007]

Element	Sizing	Investment/ reinvestment costs	Operating costs	Energy demand	Sources
Ultrafiltration membrane including required control system and pipes)	$Q_{\text{Hotel}} = 120 \text{ m}^3/\text{d}$ $A_{\text{Hotel}} = 200 \text{ m}^2$; $Q_{\text{Resid}} = 60 \text{ m}^3/\text{d}$; $A_{\text{Resid}} = 100 \text{ m}^2$; $Q_{\text{Office}} = 30 \text{ m}^3/\text{d}$; $A_{\text{Office}} = 50 \text{ m}^2$	Investment: Hotel: 21,936 €; Residential building: 10,968 €; Office building: 5,484 €; reinvestment: Hotel: 12,442 €; Residential building: 6,221 €; Office building: 3,111 €	Chemical cleaning: 0.15 €/(m ² *a): Hotel: 30 €/a; Residential building: 15 €/a; Office building: 8 €/a	See pump 3	[12]
Pump 3	$Q_{\text{Hotel}} = 120 \text{ m}^3/\text{d} = 5 \text{ m}^3/\text{h}$; $Q_{\text{Resid}} = 60 \text{ m}^3/\text{d} = 2.5 \text{ m}^3/\text{h}$; $Q_{\text{Office}} = 30 \text{ m}^3/\text{d} = 1.25 \text{ m}^3/\text{h}$	Hotel: 305 €; Residential building: 305 €; Office building: 305 €	5% of investment per year: Hotel: 15 €/a; Residential building: 15 €/a; Office building: 15 €/a	0.01 kWh/m ³ ; Hotel: 438 kWh/a; Residential building: 219 kWh/a; Office building: 110 kWh/a	[28], [33], [40]
Mechanical foam destruction	-	500 €	3% of investment per year: 15 €/a	Neglectable	[28]
Intermediate storage tank	$V_{\text{Hotel}} = 120 * 1.2 / 24 = 6 \text{ m}^3$; $V_{\text{Resid}} = 60 * 1.2 / 24 = 3 \text{ m}^3$; $V_{\text{Office}} = 30 * 1.2 / 24 = 1.5 \text{ m}^3$	Hotel: 3,500 €; Residential building: 2,500 €; Office building: 2,000 €	-	-	[18], [27]
Valve 4	DN 50	515 €	3% of investment per year: 15 €/a	Neglectable	[28], [41]

Table 14-11: Invest and operating costs of calculated elements of the black water loop system (part 5)

[12]: [Abwasserreinigung mit Membrantechnik, 2003], [13]: [Back, E. et al., 2005], [18]: [Oldenburg, M. and Dlabacs, C., 2007], [27]: [Eichhorn, U., et al., 2003], [28]: [Meinzinger, F., 2007], [34]: [Bischof, F. and Paris, S., 2007], [36]: [Larsen, T. A. and Lienert, J., 2004], [40]: [Price information of the company Jung Pumpen, 2007], [41]: [Price information of the company Albert Block GmbH, 2007], [47]: [Weinrich, L., 2007]

Element	Sizing	Investment/ reinvestment costs	Operating costs	Energy demand	Sources
Storage tank nanofiltration	$V_{\text{Hotel}} = 6 \text{ m}^3/\text{d};$ $V_{\text{Resid}} = 3 \text{ m}^3/\text{d};$ $V_{\text{Office}} = 1.5 \text{ m}^3/\text{d}$	Hotel: 3,500 € Residential building: 2,500 € Office building: 2,000 €	-	-	[18], [27]
Pump 4	$Q_{\text{Hotel}} = 1,000 \text{ m}^3/\text{d}$ $= 41.7 \text{ m}^3/\text{h};$ $Q_{\text{Resid}} = 500 \text{ m}^3/\text{d}$ $= 20.8 \text{ m}^3/\text{h};$ $Q_{\text{Office}} = 250 \text{ m}^3/\text{d}$ $= 10.4 \text{ m}^3/\text{h}$	Investment: Included in costs for membrane; Reinvestment: Hotel: 1,538 € Residential building: 981 €; Office building: 630 €	5% of investment per year: Hotel: 77 €/a; Residential building: 49 €/a; Office building: 32 €/a	2.5 kWh/m ³ ; Hotel: 91,250 kWh/a; Residential building: 45,625 kWh/a; Office building: 22,813 kWh/a	[28], [36], [40]
Nanofiltration membrane	$Q_{\text{Hotel}} = 100 \text{ m}^3/\text{d};$ $Q_{\text{Resid}} = 50 \text{ m}^3/\text{d};$ $Q_{\text{Office}} = 25 \text{ m}^3/\text{d}$	Investment: Hotel: 22,142 €; Residential building: 11,071 €; Office building: 6,000 €; reinvestment: Hotel: 13,285 €; Residential building: 6643 €; Office building: 3,321 €	Chemical cleaning: 0.15 €/(m ² *a): Hotel: 5 €/a; Residential building: 3 €/a; Office building: 1 €/a	See pump 4	[12], [13], [34], [47], chapter 8.2
Valve 5	DN 50	515 €	3% of investment per year: 15 €/a	Neglectable	[28], [41]

Table 14-12: Invest and operating costs of calculated elements of the black water loop system (part 6)

[18]: [Oldenburg, M. and Dlabacs, C., 2007], [27]: [Eichhorn, U., et al., 2003], [28]: [Meinzinger, F., 2007], [35]: [Wedi, D., 2006], [40]: [Price information of the company Jung Pumpen, 2007],

[41]: [Price information of the company Albert Block GmbH, 2007]

Element	Sizing	Investment/ reinvestment costs	Operating costs	Energy demand	Sources
Valve 6	1/2"	274 €	3% of investment per year: 8 €/a	Neglectable	[28], [41]
Valve 7	1/2"	12 €	3% of investment per year: 0.36 €/a	-	[28], [41]
Storage tank	$V_{\text{Hotel}} = 35.5 \text{ m}^3$; $V_{\text{Resid}} = 19.4 \text{ m}^3$; $V_{\text{Office}} = 17.8 \text{ m}^3$	Hotel: 22,000 €; Residential building: 15,000 €; Office building: 14,500 €	-	-	[18], [27], chapter 8.2
Pump 5	$Q_{\text{Hotel}} = 100 \text{ m}^3/\text{d}$ $= 4.2 \text{ m}^3/\text{h}$; $Q_{\text{Resid}} = 50 \text{ m}^3/\text{d}$ $= 2.1 \text{ m}^3/\text{h}$; $Q_{\text{Office}} = 25 \text{ m}^3/\text{d}$ $= 1 \text{ m}^3/\text{h}$	Hotel: 305 €; Residential building: 305 €; Office building: 305 €	5% of investment per year: Hotel: 15 €/a; Residential building: 15 €/a; Office building: 15 €/a	0.15 kW/m ³ , Hotel: 5,480 kWh/a; Residential building: 2,740 kWh/a; Office building: 1,370 kWh/a	[28], [35], [40], chapter 8.2
Pressure control system	$Q_{\text{Hotel}} = 100 \text{ m}^3/\text{d}$; $Q_{\text{Resid}} = 50 \text{ m}^3/\text{d}$; $Q_{\text{Office}} = 25 \text{ m}^3/\text{d}$	1,500 €	5 % of investment per year: 75 €/a	See pump 5	[28], chapter 8.2

Table 14-13: Invest and operating costs of calculated elements of the black water loop system (part 7)
 [18]: [Oldenburg, M. and Dlabacs, C., 2007], [19]: [Fricke, K. et al., 1989], [27]: [Eichhorn, U., et al., 2003]

Element	Sizing	Investment/ reinvestment costs	Operating costs	Energy demand	Sources
Disposal tubes (black water)	DN 100 already existing in conventional system -> use for black water, addition of just DN 50 for Greywater disposal; Hotel/ Residential Building: 3 m/p; Office building: 1 m/empl	13.26 €/m; Hotel: 79,560 €; Residential building: 79,560 €; Office building: 26,520 €	-	-	[18]
Supply tubes (flush water)	DN 50; Hotel/ Residential Building: 3m/p; Office building: 1 m/empl	13.26 €/m; Hotel: 79,560 €; Residential building: 79,560 €; Office building: 26,520 €	-	-	[18]
Control unit	-	15,000 €	-	Neglectable	
Sensors of control unit	2 floating switches, 1 pH sensor	885.84 €	Material for calibration of pH sensor: 250 €/a	Neglectable	
Lab equipment	-	5,800 €	1,040 €/a	Neglectable	[27]
Installation of a composting area	$M_{Hotel} = 68 \text{ kg/d}$; $M_{Resid} = 68 \text{ kg/d}$; $M_{Office} = 34 \text{ kg/d}$	5,000 €	personnel costs included in collective value	0.11 kWh/kg of compost (aeration); Hotel: 2,730 kWh/a; Residential building: 2,730 kWh/a; Office building: 1,365 kWh/a	[18], [19]
Personnel expenses	0.25 persons	-	34,000 €/(p*a), 8,500 €/a	-	[18]

Table 14-14: Invest and operating costs of calculated elements of the grey water loop system (part 1)

[18]: [Oldenburg, M. and Dlabacs, C., 2007], [21]: [Kegebein, J., 2007], [24]: [Guttau, S., 2005], [27]: [Eichhorn, U., et al., 2003], [28]: [Meinzinger, F., 2007], [29]: [Zernot, I., 2007a], [30]: [Zernot, I., 2007b], [41]: [Price information of the company Albert Block GmbH, 2007]

Element	Sizing	Investment/ reinvestment costs	Operating costs	Energy demand	Sources
Grease trap	-	1,000 €	5% of investment per year: 50 €/a	-	[28]
Equalisation tank	38.5 l/bed, 2.000 beds, $V_{Hotel} = 77 \text{ m}^3$; 19.2 l/inhabitant, 2.000 inhabitants, $V_{Resid} = 38.4 \text{ m}^3$; 17.4 l/employee, 2.000 employees, $V_{Office} = 34.8 \text{ m}^3$	Hotel: 35,500 €; Residential building: 23,000 €; Office building: 22,000 €	-	-	[18], [27], chapter 8.2
Valve 1	DN 50	115 €	3% of investment per year: 3 €/a	-	[28], [41]
Sieving unit	140 l/bed * d, 2.000 beds, $Q_{Hotel} = 280 \text{ m}^3/\text{d}$; 70 l/inhabitant * d, 2.000 inhabitants, $Q_{Resid} = 140 \text{ m}^3/\text{d}$; 35 l/employee * d, 2.000 employees, $Q_{Office} = 70 \text{ m}^3/\text{d}$	Hotel: 13,150 €; Residential building: 9,300 €; Office building: 6,600 €	3% of investment per year: Hotel: 395 €/a Residential building: 279 €/a Office building: 198 €/a	Hotel: 1.8 kW, 15,768 kWh/a; Residential and office bulding: 0.25 kW, 2,190 kWh/a	[27], [28], [29], [30], chapter 8.2
Container for solids	500 l	500 €	-	-	
Tank for biological treatment	$V_{Hotel} = 10,480 / 150 = 69.9 \text{ m}^3$; $V_{Resid} = 5,240 / 150 = 34.9 \text{ m}^3$; $V_{Office} = 70 / 24 * 4 = 11.7 \text{ m}^3$ (4h minimum retention time)	Hotel: 33,500 €; Residential building: 22,000 €; Office building: 11,100 €	-	-	[18], [21], [24], [27]

Table 14-15: Invest and operating costs of calculated elements of the grey water loop system (part 2)

[12]: [Abwasserreinigung mit Membrantechnik, 2003], [21]: [Kegebein, J., 2007], [28]: [Meinzinger, F., 2007], [37]: [Günthert, F. W. and Reicherter, E., 2001]

Element	Sizing	Investment/ reinvestment costs	Operating costs	Energy demand	Sources
Fixed bed material biological treatment	140 l/bed * d, BOD _{grey} = 360 mg/l, TN _{grey} = 13 mg/l, 2.000 beds, A _{Hotel} = 10,480 m ² ; 70 l/inhabitant * d, BOD _{grey} = 360 mg/l, TN _{grey} = 13 mg/l, 2.000 inhabitants, A _{Resid} = 5,240 m ² ; 35 l/employee * d, BOD _{grey} = 111 mg/l, TN _{grey} = 10 mg/l, 2.000 employees, A _{Office} = 1,047.5 m ²	100 €/m ³ ; Hotel: 6,990 €; Residential building: 3,490 €; Office building: 1,170 €	-	-	[21], chapter 8.2, table 9-5
Aeration (fine bubble, including compressor)	140 l/bed * d, BOD _{grey} = 360 mg/l, TN _{grey} = 13 mg/l, 2.000 beds, Q _{O₂, Hotel} = 9.12 kg O ₂ /h; 70 l/inhabitant * d, BOD _{grey} = 360 mg/l, TN _{grey} = 13 mg/l, 2.000 inhabitants, Q _{O₂, Resid} = 4.56 kg O ₂ /h; 35 l/employee * d, BOD _{grey} = 111 mg/l, TN _{grey} = 10 mg/l, 2.000 employees, Q _{O₂, Office} = 0.81 kg O ₂ /h	Hotel: 8.415 €; Residential building: 4.202 €; Office building: 1,409 €	5% of investment per year: Hotel: 421 €/a; Residential building: 210 €/a; Office building: 70 €/a	2.2 kg O ₂ /kWh, Hotel: 36,314 kWh/a; Residential building: 18,157 kWh/a; Office Building: 3,225 kWh/a	[28], [37], chapter 8.2, table 9-5
Aeration (cross flow, including compressor etc.)	A _{Hotel} = 470 m ² ; A _{Resid} = 235 m ² ; A _{Office} = 118 m ²	Investment included in costs for membrane, Reinvestment: Hotel: 11,155 €; Residential building: 5,578 €; Office building: 2,801 €	5% of investment per year: Hotel: 558 €/a; Residential building: 279 €/a; Office building: 140 €/a	10 W/m ² ; Hotel: 41,172 kWh/a; Residential building: 20,586 kWh/a; Office building: 10,337 kWh/a	[12], [28]

Table 14-16: Invest and operating costs of calculated elements of the grey water loop system (part 3)
 [12]:[Abwasserreinigung mit Membrantechnik, 2003] , [13]:[Back, E. et al., 2005], [18]:[Oldenburg, M. and Dlabacs, C., 2007], [27]:[Eichhorn, U., et al., 2003], [28]:[Meinzinger, F., 2007],
 [33]:[Cornel, P. and Krause, S., 2006], [40]:[Price information of the company Jung Pumpen, 2007], [41]:[Price information of the company Albert Block GmbH, 2007]

Element	Sizing	Investment/ reinvestment costs	Operating costs	Energy demand	Sources
Ultrafiltration membrane	$Q_{\text{Hotel}} = 280 \text{ m}^3/\text{d}$, $A_{\text{Hotel}} = 470 \text{ m}^2$; $Q_{\text{Resid}} = 140 \text{ m}^3/\text{d}$, $A_{\text{Resid}} = 235 \text{ m}^2$; $Q_{\text{Office}} = 70 \text{ m}^3/\text{d}$, $A_{\text{Office}} = 118 \text{ m}^2$	Investment: Hotel: 51,550 €; Residential building: 25,775 €; Office building: 12,942 €; reinvestment: Hotel: 29,239 €; Residential building: 14,619 €; Office building: 7,341 €	Chemical cleaning: $0.15 \text{ €}/(\text{m}^2 \cdot \text{a})$: Hotel: 71 €/a; Residential building: 35 €/a; Office building: 18 €/a	See pump 1	[12], [13]
Pump 1	$Q_{\text{Hotel}} = 280 \text{ m}^3/\text{d}$ $= 11.7 \text{ m}^3/\text{h}$; $Q_{\text{Resid}} = 140 \text{ m}^3/\text{d}$ $= 5.8 \text{ m}^3/\text{h}$; $Q_{\text{Office}} = 70 \text{ m}^3/\text{d}$ $= 2.9 \text{ m}^3/\text{h}$	Investment: Included in costs for membrane; Reinvestment: Hotel: 676 €; Residential building: 340 €; Office building: 305 €	5% of investment per year: Hotel: 34 €/a; Residential building: 17 €/a; Office building: 15 €/a	$0.01 \text{ kWh}/\text{m}^3$; Hotel: 1,022 kWh/a; Residential building: 511 kWh/a; Office building: 256 kWh/a	[28], [33], [40]
Mechanical foam destruction	-	500 €	3% of investment per year: 15 €/a	Neglectable	[28]
Intermediate storage tank	20 cycles per day; $V_{\text{Hotel}} = 140 \cdot 1.2 / 24$ $= 7 \text{ m}^3$; $V_{\text{Resid}} = 70 \cdot 1.2 / 24$ $= 3.5 \text{ m}^3$; $V_{\text{Office}} = 35 \cdot 1.2 / 24$ $= 1.75 \text{ m}^3$	Hotel: 4,000 €; Residential building: 2,750 €; Office building: 2,100 €	-	-	[18], [27], chapter 8.2
Valve 2	DN 50	515 €	3% of investment per year: 15 €/a	Neglectable	[28], [41]

Table 14-17: Invest and operating costs of calculated elements of the grey water loop system (part 4)

[1]: [fbr H 201 - Grauwasser-Recycling, 2005], [18]: [Oldenburg, M. and Dlabacs, C., 2007], [27]: [Eichhorn, U., et al., 2003], [28]: [Meininger, F., 2007], [40]: [Price information of the company Jung Pumpen, 2007], [41]: [Price information of the company Albert Block GmbH, 2007], [43]: [Homepage of the company AquaCare Systems Research, 2007], [44]: [Homepage of the company glm-Wassertechnik, 2007]

Element	Sizing	Investment/ reinvestment costs	Operating costs	Energy demand	Sources
Tank reverse osmosis	$V_{\text{Hotel}} = 7 \text{ m}^3$; $V_{\text{Resid}} = 3.5 \text{ m}^3$; $V_{\text{Office}} = 1.75 \text{ m}^3$	Hotel: 4,000 €; Residential building: 2,750 €; Office building: 2,100 €	-	-	[18], [27], chapter 8.2
Pump 2	$Q_{\text{Hotel}} = 2,800 \text{ m}^3/\text{d}$ $= 116.7 \text{ m}^3/\text{h}$; $Q_{\text{Resid}} = 1,400 \text{ m}^3/\text{d}$ $= 58.3 \text{ m}^3/\text{h}$; $Q_{\text{Office}} = 700 \text{ m}^3/\text{d}$ $= 29.2 \text{ m}^3/\text{h}$	Investment: Included in costs for membrane; Reinvestment: Hotel: 3,000 €; Residential building: 1,911 €; Office building: 1,221 €	5% of investment per year: Hotel: 150 €/a; Residential building: 96 €/a; Office building: 61 €/a	4 kWh/m ³ passing membrane; Hotel: 408,800 kWh/a; Residential building: 204,400 kWh/a; Office building: 102,200 kWh/a	[28], [40], [43], [44]
Valve 3	DN 50	515 €	3% of investment per year: 15 €/a	Neglectable	[28], [41]
Valve 4	DN 50	515 €	3% of investment per year: 15 €/a	Neglectable	[28], [41]
Tank service water	10% of daily flow; $V_{\text{Hotel}} = 28 \text{ m}^3$; $V_{\text{Resid}} = 14 \text{ m}^3$; $V_{\text{Office}} = 7 \text{ m}^3$	Hotel: 19,000 €; Residential building: 12,500 €; Office building: 4,000 €	-	-	[1], [18], [27]
Supply tubes (service water)	DN 50, 50 m (selected)	13.26 €/m; 663 €	-	-	

Table 14-18: Invest and operating costs of calculated elements of the grey water loop system (part 5)

[12]: [Abwasserreinigung mit Membrantechnik, 2003], [22]: [Arbeitsblatt DWA-A 138, 2005],
 [32]: [Dezentrale naturnahe Regenwasserbewirtschaftung, 2006], [34]: [Bischof, F. and Paris, S.,
 2007], [38]: [Beise, D., 2007], [47]: [Weinrich, L., 2007]

Element	Sizing	Investment/ reinvestment costs	Operating costs	Energy demand	Sources
Reverse osmosis membrane	80% of flow; $Q_{\text{Hotel}} = 0.8 * 280 \text{ m}^3/\text{d}$ $= 224 \text{ m}^3/\text{d}$; $Q_{\text{Resid}} = 0.8 * 140 \text{ m}^3/\text{d}$ $= 112 \text{ m}^3/\text{d}$; $Q_{\text{Office}} = 0.8 * 70 \text{ m}^3/\text{d}$ $= 56 \text{ m}^3/\text{d}$	Investment: Hotel: 36,860 €; Residential building: 18,430 €; Office building: 9,215 €; reinvestment: Hotel: 22,116 €; Residential building: 11,058 €; Office building: 5,529 €	Chemical cleaning: $0.15 \text{ €}/(\text{m}^2 \cdot \text{a})$: Hotel: 12 €/a; Residential building: 6 €/a; Office building: 3 €/a	See pump 2	[12], [34], [47]
Soil infiltration	90% of flow; $Q_{\text{Hotel}} = 0.9 * 280 \text{ m}^3/\text{d}$ $= 252 \text{ m}^3/\text{d}$, $A_{\text{infil, hotel}} = 11.7 \text{ m}^2$; $Q_{\text{Resid}} = 0.9 * 140 \text{ m}^3/\text{d}$ $= 126 \text{ m}^3/\text{d}$, $A_{\text{infil, resid}} = 5.8 \text{ m}^2$; $Q_{\text{Office}} = 0.9 * 70 \text{ m}^3/\text{d}$ $= 63 \text{ m}^3/\text{d}$, $A_{\text{infil, office}} = 2.9 \text{ m}^2$	5 €/m ² ; Hotel: 59 €; Residential building: 29 €; Office building: 15 €	-	-	[22], [32]
Sealing of ground passage	depth 2 m; $\text{Surface}_{\text{hotel}} = 504 \text{ m}^2$, $l_{\text{hotel}} = 22 \text{ m}$, $A_{\text{sealing, hotel}} = 680 \text{ m}^2$; $\text{Surface}_{\text{resid}} = 252 \text{ m}^2$, $l_{\text{resid}} = 16 \text{ m}$, $A_{\text{sealing, resid}} = 380 \text{ m}^2$; $\text{Surface}_{\text{office}} = 126 \text{ m}^2$, $l_{\text{office}} = 11 \text{ m}$, $A_{\text{sealing, office}} = 214 \text{ m}^2$	Hotel: 2,278 €; Residential building: 1,273 €; Office building: 717 €	-	-	[38]

Table 14-19: Invest and operating costs of calculated elements of the grey water loop system (part 6)

[14]: [Hamacher, R., 2000], [18]: [Oldenburg, M. and Dlabacs, C., 2007], [22]: [Arbeitsblatt DWA-A 138, 2005], [23]: [Gujer, W., 1999], [27]: [Eichhorn, U., et al., 2003], [28]: [Meinzinger, F., 2007], [35]: [Wedi, D., 2006], [38]: [Beise, D., 2007], [40]: [Price information of the company Jung Pumpen, 2007]

Element	Sizing	Investment/ reinvestment costs	Operating costs	Energy demand	Sources
Filtermaterial of ground passage	$V_{\text{Hotel}} = 1,008 \text{ m}^3$; $V_{\text{Resid}} = 504 \text{ m}^3$; $V_{\text{Office}} = 252 \text{ m}^3$	Hotel: 13,496 €; Residential building: 6,748 €; Office building: 3,374 €	-	-	[38]
Well	$Q_{\text{Hotel}} = 252 \text{ m}^3/\text{d}$; $Q_{\text{Resid}} = 126 \text{ m}^3/\text{d}$; $Q_{\text{Office}} = 63 \text{ m}^3/\text{d}$ DN 1000, H = 2.0 m, coarse sand ($k_f = 5 \cdot 10^{-4}$)	264 €/m; 528 €	-	-	[14], [22]
Pump 3	$Q_{\text{Hotel}} = 252 \text{ m}^3/\text{d}$ = 10.5 m ³ /h; $Q_{\text{Resid}} = 126 \text{ m}^3/\text{d}$ = 5.3 m ³ /h; $Q_{\text{Office}} = 63 \text{ m}^3/\text{d}$ = 2.6 m ³ /h	Hotel: 630 € Residential building: 323 € Office building: 305 €	5% of investment per year: Hotel: 32 €/a; Residential building: 16 €/a; Office building: 15 €/a	0.015 kW/m ³ , Hotel: 1,380 kWh/a; Residential building: 690 kWh/a; Office building: 345 kWh/a	[28], [35], [40]
Sand filtration	$Q_{\text{Hotel}} = 252 \text{ m}^3/\text{d}$, $v_{\text{filtration}} = 10 \text{ m/h}$, $A_{\text{filter, hotel}} = 1.05 \text{ m}^2$; $Q_{\text{Resid}} = 126 \text{ m}^3/\text{d}$; $v_{\text{filtration}} = 10 \text{ m/h}$, $A_{\text{filter, resid}} = 0.53 \text{ m}^2$; $Q_{\text{Office}} = 63 \text{ m}^3/\text{d}$ $v_{\text{filtration}} = 10 \text{ m/h}$, $A_{\text{filter, office}} = 0.26 \text{ m}^2$;	1,000 €	-	See pump 3	[23]
Storage tank	$V_{\text{Hotel}} = 77 \text{ m}^3$; $V_{\text{Resid}} = 38.4 \text{ m}^3$; $V_{\text{Office}} = 34.8 \text{ m}^3$	Hotel: 35,500 €; Residential building: 23,000 €; Office building: 22,000 €	-	-	[18], [27], chapter 8.2

Table 14-20: Invest and operating costs of calculated elements of the grey water loop system (part 7)

[15]: [Homepage of the company sterilAir, 2007], [18]: [Oldenburg, M. and Dlabacs, C., 2007], [28]: [Meinzinger, F., 2007], [31]: [Orbach, R., 2007], [35]: [Wedi, D., 2006], [40]: [Price information of the company Jung Pumpen, 2007], [41]: [Price information of the company Albert Block GmbH, 2007]

Element	Sizing	Investment/ reinvestment costs	Operating costs	Energy demand	Sources
Valve 5	DN 50	515 €	3% of investment per year: 15 €/a	Neglectable	[28], [41]
Pump 4	Q _{Hotel} = 280 m ³ /d = 11.7 m ³ /h; Q _{Resid} = 140 m ³ /d = 5.8 m ³ /h; Q _{Office} = 70 m ³ /d = 2.9 m ³ /h	Hotel: 676 €; Residential building: 340 €; Office building: 305 €	5% of investment per year: Hotel: 34 €/a; Residential building: 17 €/a; Office building: 15 €/a	0.15 kW/m ³ , Hotel: 15,330 kWh/a; Residential building: 7,670 kWh/a; Office building: 3,830 kWh/a	[28], [35], [40]
UV reactor	Q _{Hotel} = 280 m ³ /d; Q _{Resid} = 140 m ³ /d; Q _{Office} = 70 m ³ /d	Hotel: 2,304 €; Residential and office building: 1,829 €	3% of investment per year: Hotel: 69 €/a; Residential building: 55 €/a; Office building: 55 €/a	-	[28], [31]
UV emitter	400 J/m ²	525 €	See energy demand	0.24 kW	[15]
Pressure control system	Q _{Hotel} = 280 m ³ /d; Q _{Resid} = 140 m ³ /d; Q _{Office} = 70 m ³ /d	1,500 €	5 % of investment cost per year: 75 €/a	See pump 4	[28]
Disposal tubes (grey water) Supply tubes (drinking water)	Already included in end-of-pipe system (no calculation for cost comparison necessary)				
Control unit	Already included in black water loop costs				
Sensors of control unit	2 floating switches	100 €	-	Neglectable	
Lab equipment	Already included in black water loop costs				
Personnel expenses	0.20 persons	-	34,000 €/(p*a), 6,800 €/a	-	[18]

Table 14-21: Invest and operating costs of calculated elements of the service water system (part 1)

[18]: [Oldenburg, M. and Dlabacs, C., 2007], [21]: [Kegebein, J., 2007], [24]: [Guttau, S., 2005], [27]: [Eichhorn, U., et al., 2003], [28]: [Meinzinger, F., 2007], [29]: [Zernot, I., 2007a], [30]: [Zernot, I., 2007b], [41]: [Price information of the company Albert Block GmbH, 2007]

Element	Sizing	Investment/ reinvestment costs	Operating costs	Energy demand	Sources
Grease trap	-	1,000 €	5% of investment per year: 50 €/a	-	[28]
Equalisation tank	38.5 l/bed, 2.000 beds, $V_{\text{Hotel}} = 77 \text{ m}^3$; 19.2 l/inhabitant, 2.000 inhabitants, $V_{\text{Resid}} = 38.4 \text{ m}^3$; 17.4 l/employee, 2.000 employees, $V_{\text{Office}} = 34.8 \text{ m}^3$	Hotel: 35,500 €; Residential building: 23,000 €; Office building: 22,000 €	-	-	[18], [27], chapter 8.2
Valve 1	DN 50	115 €	3% of investment per year: 3 €/a	-	[28], [41]
Sieving unit	140 l/bed * d, 2.000 beds, $Q_{\text{Hotel}} = 280 \text{ m}^3/\text{d}$; 70 l/inhabitant * d, 2.000 inhabitants, $Q_{\text{Resid}} = 140 \text{ m}^3/\text{d}$; 35 l/employee * d, 2.000 employees, $Q_{\text{Office}} = 70 \text{ m}^3/\text{d}$	Hotel: 13,150 €; Residential building: 9,300 €; Office building: 6,600 €	3% of investment per year: Hotel: 395 €/a Residential building: 279 €/a Office building: 198 €/a	Hotel: 1.8 kW, 15,768 kWh/a; Residential and office building: 0.25 kW, 2,190 kWh/a	[27], [28], [29], [30], chapter 8.2
Container for solids	500 l	500 €	-	-	
Tank for biological treatment	$V_{\text{Hotel}} = 10,480 / 150 = 69.9 \text{ m}^3$; $V_{\text{Resid}} = 5,240 / 150 = 34.9 \text{ m}^3$; $V_{\text{Office}} = 70 / 24 * 4 = 11.7 \text{ m}^3$ (4h minimum retention time)	Hotel: 33,500 €; Residential building: 22,000 €; Office building: 11,100 €	-	-	[18], [21], [24], [27]

Table 14-22: Invest and operating costs of calculated elements of the service water system (part 2)

[12]: [Abwasserreinigung mit Membrantechnik, 2003], [21]: [Kegebein, J., 2007], [28]: [Meininger, F., 2007], [37]: [Günthert, F. W. and Reicherter, E., 2001]

Element	Sizing	Investment/ reinvestment costs	Operating costs	Energy demand	Sources
Fixed bed material biological treatment	140 l/bed * d, BOD _{grey} = 360 mg/l, TN _{grey} = 13 mg/l, 2.000 beds, A _{Hotel} = 10,480 m ² ; 70 l/inhabitant * d, BOD _{grey} = 360 mg/l, TN _{grey} = 13 mg/l, 2.000 inhabitants, A _{Resid} = 5,240 m ² ; 35 l/employee * d, BOD _{grey} = 111 mg/l, TN _{grey} = 10 mg/l, 2.000 employees, A _{Office} = 1,047.5 m ²	100 €/m ³ ; Hotel: 6,990 €; Residential building: 3,490 €; Office building: 1,170 €	-	-	[21], chapter 8.2, table 9-5
Aeration (fine bubble, including compressor)	140 l/bed * d, BOD _{grey} = 360 mg/l, TN _{grey} = 13 mg/l, 2.000 beds, Q _{O₂, Hotel} = 9.12 kg O ₂ /h; 70 l/inhabitant * d, BOD _{grey} = 360 mg/l, TN _{grey} = 13 mg/l, 2.000 inhabitants, Q _{O₂, Resid} = 4.56 kg O ₂ /h; 35 l/employee * d, BOD _{grey} = 111 mg/l, TN _{grey} = 10 mg/l, 2.000 employees, Q _{O₂, Office} = 0.81 kg O ₂ /h	Hotel: 8.415 €; Residential building: 4.202 €; Office building: 1,409 €	5% of investment per year: Hotel: 421 €/a; Residential building: 210 €/a; Office building: 70 €/a	2.2 kg O ₂ /kWh, Hotel: 36,314 kWh/a; Residential building: 18,157 kWh/a; Office Building: 3,225 kWh/a	[28], [37], chapter 8.2, table 9-5
Aeration (cross flow, including compressor etc.)	A _{Hotel} = 470 m ² ; A _{Resid} = 235 m ² ; A _{Office} = 118 m ²	Investment included in costs for membrane, Reinvestment: Hotel: 11,155 €; Residential building: 5,578 €; Office building: 2,801 €	5% of investment per year: Hotel: 558 €/a; Residential building: 279 €/a; Office building: 140 €/a	10 W/m ² ; Hotel: 41,172 kWh/a; Residential building: 20,586 kWh/a; Office building: 10,337 kWh/a	[12], [28]

Table 14-23: Invest and operating costs of calculated elements of the service water system (part 4)

[1]: [fbr H 201 - Grauwasser-Recycling, 2005], [12]: [Abwasserreinigung mit Membrantechnik, 2003],
 [13]: [Back, E. et al., 2005], [28]: [Meinzinger, F., 2007], [33]: [Cornel, P. and Krause, S., 2006],
 [40]: [Price information of the company Jung Pumpen, 2007]

Element	Sizing	Investment/ reinvestment costs	Operating costs	Energy demand	Sources
Ultrafiltration membrane	$Q_{\text{Hotel}} = 280 \text{ m}^3/\text{d}$, $A_{\text{Hotel}} = 470 \text{ m}^2$; $Q_{\text{Resid}} = 140 \text{ m}^3/\text{d}$, $A_{\text{Resid}} = 235 \text{ m}^2$; $Q_{\text{Office}} = 70 \text{ m}^3/\text{d}$, $A_{\text{Office}} = 118 \text{ m}^2$	Investment: Hotel: 51,550 €; Residential building: 25,775 €; Office building: 12,942 €; reinvestment: Hotel: 29,239 €; Residential building: 14,619 €; Office building: 7,341 €	Chemical cleaning: $0.15 \text{ €}/(\text{m}^2 \cdot \text{a})$: Hotel: 71 €/a; Residential building: 35 €/a; Office building: 18 €/a	See pump 1	[12], [13]
Pump 1	$Q_{\text{Hotel}} = 280 \text{ m}^3/\text{d}$ $= 11.7 \text{ m}^3/\text{h}$; $Q_{\text{Resid}} = 140 \text{ m}^3/\text{d}$ $= 5.8 \text{ m}^3/\text{h}$; $Q_{\text{Office}} = 70 \text{ m}^3/\text{d}$ $= 2.9 \text{ m}^3/\text{h}$	Investment: Included in costs for membrane; Reinvestment: Hotel: 676 €; Residential building: 340 €; Office building: 305 €	5% of investment per year: Hotel: 34 €/a; Residential building: 17 €/a; Office building: 15 €/a	$0.01 \text{ kWh}/\text{m}^3$; Hotel: 1022 kWh/a; Residential building: 511 kWh/a; Office building: 256 kWh/a	[28], [33], [40]
Mechanical foam destruction	-	500 €	3% of investment per year: 15 €/a	Neglectable	[28]
Storage tank service water	1 d storage; $V_{\text{Hotel}} = 112 \text{ m}^3$; $V_{\text{Resid}} = 36 \text{ m}^3$; $V_{\text{Office}} = 40 \text{ m}^3$	Hotel: 45,000 €; Residential building: 22,500 €; Office building: 24,000 €	-	-	[1]

Table 14-24: Invest and operating costs of calculated elements of the service water system (part 5)

[15]: [Homepage of the company sterilAir, 2007], [22]: [Arbeitsblatt DWA-A 138, 2005],
 [28]: [Meinzinger, F., 2007], [31]: [Orbach, R., 2007], [32]: [Dezentrale naturnahe
 Regenwasserbewirtschaftung, 2006], [35]: [Wedi, D., 2006], [40]: [Price information of the company
 Jung Pumpen, 2007], [41]: [Price information of the company Albert Block GmbH, 2007]

Element	Sizing	Investment/ reinvestment costs	Operating costs	Energy demand	Sources
Soil infiltration	$Q_{\text{Hotel}} = (280 - 112) \text{ m}^3/\text{d}$ $= 168 \text{ m}^3/\text{d}$, $A_{\text{infil, hotel}} = 7.78 \text{ m}^2$; $Q_{\text{Resid}} = (140 - 36) \text{ m}^3/\text{d}$ $= 104 \text{ m}^3/\text{d}$, $A_{\text{infil, resid}} = 4.81 \text{ m}^2$; $Q_{\text{Office}} = (70 - 40) \text{ m}^3/\text{d}$ $= 30 \text{ m}^3/\text{d}$, $A_{\text{infil, office}} = 1.39 \text{ m}^2$	5 €/m ² ; Hotel: 840 €; Residential building: 520 €; Office building: 150 €	-	-	[22], [32]
Valve 2	DN 50	515 €	3% of investment per year: 15 €/a	Neglectable	[28], [41]
Pump 2	$Q_{\text{Hotel}} = 112 \text{ m}^3/\text{d}$ $= 4.7 \text{ m}^3/\text{h}$; $Q_{\text{Resid}} = 36 \text{ m}^3/\text{d}$ $= 1.5 \text{ m}^3/\text{h}$; $Q_{\text{Office}} = 30 \text{ m}^3/\text{d}$ $= 1.25 \text{ m}^3/\text{h}$	Hotel: 305 €; Residential building: 305 €; Office building: 305 €	5% of investment per year: Hotel: 15 €/a; Residential building: 15 €/a; Office building: 15 €/a	0.15 kW/m ³ , Hotel: 6,130 kWh/a; Residential building: 1,970 kWh/a; Office building: 1,640 kWh/a	[28], [35], [40]
UV reactor	$Q_{\text{Hotel}} = 112 \text{ m}^3/\text{d}$ $= 4.7 \text{ m}^3/\text{h}$; $Q_{\text{Resid}} = 36 \text{ m}^3/\text{d}$ $= 1.5 \text{ m}^3/\text{h}$; $Q_{\text{Office}} = 30 \text{ m}^3/\text{d}$ $= 1.25 \text{ m}^3/\text{h}$	1,829 €	3% of investment per year: 55 €/a	-	[28], [31]
UV emitter	400 J/m ²	525 €	See energy demand	0.24 kW	[15]
Pressure control system	$Q_{\text{Hotel}} = 112 \text{ m}^3/\text{d}$ $= 4.7 \text{ m}^3/\text{h}$; $Q_{\text{Resid}} = 36 \text{ m}^3/\text{d}$ $= 1.5 \text{ m}^3/\text{h}$; $Q_{\text{Office}} = 30 \text{ m}^3/\text{d}$ $= 1.25 \text{ m}^3/\text{h}$	1,500 €	5 % of investment cost per year: 75 €/a	See pump 2	[28]

Table 14-25: Invest and operating costs of calculated elements of the service water system (part 6)

[18]: [Oldenburg, M. and Dlabacs, C., 2007]

Element	Sizing	Investment/ reinvestment costs	Operating costs	Energy demand	Sources
Disposal tubes (grey water)	Already included in black water loop costs				
Supply tubes (service water)	DN 50; Hotel/ Residential Building: Δ 3m/bed, Δ 3m/p; Office building: Δ 1 m/empl	13.26 €/m; Hotel: 79,560 €; Residential building: 79,560 €; Office building: 26,520 €	-	-	[18]
Control unit	Already included in black water loop costs				
Sensors of control unit	2 floating switches	100 €	-	neglectable	
Lab equipment	Already included in black water loop costs				
Personnel expenses	0.10 persons	-	34,000 €/(p*a), 3,400 €/a	-	[18]

Table 14-26: Total project costs and annual costs for an application in a hotel for the initial values of the variables

Hotel	Initial values for variables			
	Standard waste water fees	Waste water fees according to contamination	Standard waste water fees + redundancies	Waste water fees according to contamination
Total project costs [€]				
EoP	15,296,708	16,057,044	15,296,708	16,057,044
BWL + GWL	6,135,513	6,141,513	7,640,241	7,644,241
BWL + GWP	5,008,646	5,008,646	6,192,704	6,192,704
BWL + EoP	13,113,873	13,674,121	13,662,404	14,222,652
Annual costs [€/a]				
EoP	594,514	624,065	594,514	624,065
BWL + GWL	238,460	238,693	296,942	297,097
BWL + GWP	194,663	194,663	240,682	240,682
BWL + EoP	509,677	531,451	530,996	552,770

Table 14-27: Total project costs and annual costs for an application in an office building for the initial values of the variables

Office building	Initial values for variables			
	Standard waste water fees	Waste water fees according to contamination	Standard waste water fees + redundancies	Waste water fees according to contamination
Total project costs [€]				
EoP	4,066,160	4,682,183	4,066,160	4,682,183
BWL + GWL	2,341,134	2,341,134	2,877,487	2,873,287
BWL + GWP	1,930,298	1,930,298	2,376,072	2,376,072
BWL + EoP	4,074,440	4,378,540	4,323,447	4,627,547
Annual costs [€/a]				
EoP	158,033	181,975	158,033	181,975
BWL + GWL	90,989	90,989	111,835	111,672
BWL + GWP	75,022	75,022	92,347	92,347
BWL + EoP	158,355	170,174	168,033	179,852

Table 14-28: Total project costs and annual costs for an application in a residential building for the initial values of the variables

Residential building	Initial values for variables			
	Standard waste water fees	Waste water fees according to contamination	Standard waste water fees + redundancies	Waste water fees according to contamination
Total project costs [€]				
EoP	7,980,836	9,761,980	7,980,836	9,761,980
BWL + GWL	3,707,235	3,707,235	4,570,732	4,565,232
BWL + GWP	3,632,340	3,632,340	4,329,978	4,329,978
BWL + EoP	7,238,939	8,551,360	7,589,066	8,901,488
Annual costs [€/a]				
EoP	310,179	379,404	310,179	379,404
BWL + GWL	144,084	144,084	177,644	177,430
BWL + GWP	141,173	141,173	168,287	168,287
BWL + EoP	281,345	332,353	294,953	345,961

Table 14-29: Intersection points resulting from the sensitivity analysis regarding varying rates of interest for application of the systems in a hotel

Rate of interest	Total project costs [€]			
	EoP	BWL + GWL	BWL + GWP	BWL + EoP
14.3573%	4,245,113	2,614,188	2,326,567	4,245,113
33.9251%	1,885,081	1,885,081	1,773,284	2,364,134
36.9895%	1,741,323	1,842,733	1,741,323	2,250,593
75.5240%	929,288	1,613,366	1,568,805	1,613,366
83.7999%	852,308	1,592,791	1,553,366	1,553,366
864.8000%	217,884	1,434,167	1,434,167	1,061,345

Table 14-30: Intersection point resulting from the sensitivity analysis regarding varying drinking water fees for application of the systems in a hotel

Percentage	Total project costs [€]				Water price [€m ³]
	EoP	BWL + GWL	BWL + GWP	BWL + EoP	
240.9655%	22,943,314	6,739,193	6,739,193	18,748,214	3.66

Table 14-31: Intersection points resulting from the sensitivity analysis regarding varying waste water fees for application of the systems in a hotel

Percentage	Total project costs [€]				Waste water fee [€m ³]
	EoP	BWL + GWL	BWL + GWP	BWL + EoP	
0.5007%	6,135,513	6,135,513	5,008,646	6,363,518	0.01
9.9109%	7,001,936	6,135,513	5,008,646	7,001,936	0.26

Table 14-32: Intersection points resulting from the sensitivity analysis regarding varying drinking and waste water fees for application of the systems in a hotel

Percentage	Total project costs [€]				Water price [€m ³]	Waste water fee [€m ³]
	EoP	BWL + GWL	BWL + GWP	BWL + EoP		
15.1609%	2,883,268	5,772,193	3,967,128	3,967,128	0.23	0.39
23.2469%	4,066,395	5,806,821	4,066,395	4,838,906	0.35	0.60
32.5960%	5,434,330	5,846,858	4,181,168	5,846,858	0.50	0.84
35.5004%	5,859,296	5,859,296	4,216,824	6,159,990	0.54	0.92
43.3097%	7,001,934	5,892,739	4,312,694	7,001,934	0.66	1.12
240.9655%	35,922,421	6,739,193	6,739,193	28,311,767	3.66	6.22

Table 14-33: Intersection points resulting from the sensitivity analysis regarding a varying energy price (constant water fees) for application of the systems in a hotel

Percentage	Total project costs [€]				Energy price [€/kWh]
	EoP	BWL + GWL	BWL + GWP	BWL + EoP	
29.2473%	15,003,003	4,272,460	4,272,460	12,666,377	0.04
448.7940%	16,744,604	15,319,921	8,637,864	15,319,921	0.66
513.0246%	17,011,235	17,011,235	9,306,187	15,726,166	0.76
1104.2310%	19,465,421	32,578,823	15,457,720	19,465,421	1.63
1745.0633%	22,125,612	49,453,155	22,125,612	23,518,549	2.58
2086.4475%	23,542,748	58,442,450	25,677,732	25,677,732	3.08

Table 14-34: Intersection points resulting from the sensitivity analysis regarding a varying energy price with direct effect on water fees and contamination related water fees for application of the systems in a hotel

Percentage	Total project costs [€]				Water price [€/m ³]	Waste water fee [€/m ³]	Energy price [€/kWh]
	EoP	BWL + GWL	BWL + GWP	BWL + EoP			
28.0407%	15,547,559	4,239,607	4,239,607	13,063,688	1.49	2.76	0.04
519.7076%	19,028,653	17,234,511	9,494,117	17,234,511	1.67	2.99	0.77
612.4275%	19,685,127	19,685,127	10,485,027	18,021,057	1.70	3.03	0.90
1798.6440%	28,083,762	51,037,186	23,162,283	28,083,762	2.11	3.59	2.65
3163.0882%	37,744,283	87,099,858	37,744,283	39,658,378	2.59	4.24	4.67
4031.5095%	43,892,868	110,052,495	47,025,218	47,025,218	2.89	4.65	5.95

Table 14-35: Intersection points resulting from the sensitivity analysis regarding varying energy, drinking water and waste water fees for application of the systems in a hotel

Percentage	Total project costs [€]				Water price [€/m ³]	Waste water fee [€/m ³]	Energy price [€/kWh]
	EoP	BWL + GWL	BWL + GWP	BWL + EoP			
11.3759%	1,961,557	3,422,341	2,998,522	2,998,522	0.17	0.29	0.02
16.4501%	2,725,075	3,577,687	3,113,614	3,577,687	0.25	0.42	0.02
19.4906%	3,182,577	3,670,770	3,182,577	3,924,724	0.30	0.50	0.03
23.5639%	3,795,470	3,795,470	3,274,964	4,389,632	0.36	0.61	0.03
39.9180%	6,256,260	4,296,142	3,645,900	6,256,260	0.61	1.03	0.06

Table 14-36: Intersection points resulting from the sensitivity analysis regarding a varying surcharge for engineering etc for application of the systems in a hotel

Percentage	Total project costs [€]			
	EoP	BWL + GWL	BWL + GWP	BWL + EoP
448.2744%	15,296,708	10,557,548	9,014,325	15,296,708
821.5253%	15,296,708	15,296,708	13,307,273	17,636,086
994.4971%	15,296,708	17,492,928	15,296,708	18,720,199
1185.3810%	15,296,708	19,916,578	17,492,161	19,916,578
1648.5924%	15,296,708	25,797,966	22,819,789	22,819,789

Table 14-37: Intersection points resulting from the sensitivity analysis regarding varying rates of interest for application of the systems in an office building

Rate of interest	Total project costs [€]			
	EoP	BWL + GWL	BWL + GWP	BWL + EoP
2.9188%	4,127,282	2,368,353	1,950,982	4,127,282
19.1599%	944,111	944,111	868,396	1,372,817
22.3121%	831,974	895,841	831,974	1,277,083
356.5000%	192,507	646,507	646,507	745,130

Table 14-38: Intersection point resulting from the sensitivity analysis regarding varying drinking water fees for application of the systems in an office building

Percentage	Total project costs [€]				Water price [€/m ³]
	EoP	BWL + GWL	BWL + GWP	BWL + EoP	
102.3200%	4,097,622	2,344,446	1,936,921	4,097,622	1.56
387.8035%	7,969,100	2,751,970	2,751,970	6,950,291	5.89

Table 14-39: Intersection points resulting from the sensitivity analysis regarding varying waste water fees for application of the systems in an office building

Percentage	Total project costs [€]				Waste water fee [€/m ³]
	EoP	BWL + GWL	BWL + GWP	BWL + EoP	
7.2100%	1,930,298	2,341,134	1,930,298	2,500,647	0.19
25.0583%	2,341,134	2,341,134	1,930,298	2,803,368	0.65
101.3669%	4,097,624	2,341,134	1,930,298	4,097,624	2.62

Table 14-40: Intersection points resulting from the sensitivity analysis regarding varying drinking and waste water fees for application of the systems in an office building

Percentage	Total project costs [€]				Water price [€/m ³]	Waste water fee [€/m ³]
	EoP	BWL + GWL	BWL + GWP	BWL + EoP		
11.0250%	811,509	2,214,123	1,676,276	1,676,276	0.17	0.28
32.0957%	1,582,264	2,244,201	1,736,433	2,244,201	0.49	0.83
36.6671%	1,749,484	2,250,727	1,749,484	2,367,415	0.56	0.95
50.9265%	2,271,082	2,271,082	1,790,194	2,751,750	0.77	1.31
100.8601%	4,097,622	2,342,362	1,932,753	4,097,622	1.53	2.60
387.8035%	14,593,828	2,751,970	2,751,970	11,831,669	5.89	10.01

Table 14-41: Intersection points resulting from the sensitivity analysis regarding a varying energy price (constant water fees) for application of the systems in an office building

Percentage	Total project costs [€]				Energy price [€/kWh]
	EoP	BWL + GWL	BWL + GWP	BWL + EoP	
455.2267%	4,803,459	4,803,459	2,979,696	4,840,767	0.67
463.0410%	4,819,679	4,857,625	3,002,781	4,857,625	0.68
2531.0100%	9,111,903	19,192,166	9,111,903	9,318,836	3.74
2790.6910%	9,650,890	20,992,197	9,879,043	9,879,043	4.12

Table 14-42: Intersection points resulting from the sensitivity analysis regarding a varying energy price with direct effect on water fees and contamination related water fees for application of the systems in an office building

Percentage	Total project costs [€]				Water price [€/m ³]	Waste water fee [€/m ³]	Energy price [€/kWh]
	EoP	BWL + GWL	BWL + GWP	BWL + EoP			
596.1767%	6,184,075	5,796,757	3,428,635	5,796,757	1.69	3.63	0.88
694.5416%	6,481,819	6,481,819	3,725,674	6,077,912	1.73	3.70	1.03
15261.6900%	50,575,576	107,934,732	47,715,056	47,715,056	6.82	14.14	22.53

Table 14-43: Intersection points resulting from the sensitivity analysis regarding varying energy, drinking water and waste water fees for application of the systems in an office building

Percentage	Total project costs [€]				Water price [€/m ³]	Waste water fee [€/m ³]	Energy price [€/kWh]
	EoP	BWL + GWL	BWL + GWP	BWL + EoP			
7.9821%	509,215	1,571,939	1,395,753	1,395,753	0.12	0.21	0.01
16.4725%	837,410	1,642,912	1,445,075	1,642,912	0.25	0.42	0.02
34.9731%	1,552,547	1,797,561	1,552,547	2,181,472	0.53	0.90	0.05
43.0605%	1,865,165	1,865,165	1,599,528	2,416,901	0.65	1.11	0.06
100.8675%	4,099,693	2,348,385	1,935,337	4,099,693	1.53	2.60	0.15

Table 14-44: Intersection points resulting from the sensitivity analysis regarding a varying surcharge for engineering etc for application of the systems in an office building

Percentage	Total project costs [€]			
	EoP	BWL + GWL	BWL + GWP	BWL + EoP
98.1475%	4,066,160	2,331,608	1,921,376	4,066,160
435.4836%	4,066,160	4,066,160	3,546,024	5,573,947
543.4826%	4,066,160	4,621,481	4,066,160	6,056,669
2678.4840%	4,066,160	15,599,463	14,348,565	15,599,463
6289.3900%	4,066,160	34,166,413	31,739,092	31,739,092

Table 14-45: Intersection points resulting from the sensitivity analysis regarding varying rates of interest for application of the systems in a residential building

Rate of interest	Total project costs [€]			
	EoP	BWL + GWL	BWL + GWP	BWL + EoP
7.8435%	3,941,232	2,311,070	2,309,961	3,941,232
7.9805%	3,881,514	2,290,333	2,290,333	3,892,443
22.1467%	1,524,024	1,481,320	1,524,024	1,972,735
23.2249%	1,460,252	1,460,252	1,504,011	1,921,298
64.3740%	622,606	1,197,379	1,253,073	1,253,073
84.2575%	511,034	1,165,413	1,222,162	1,165,413

Table 14-46: Intersection point resulting from the sensitivity analysis regarding varying drinking water fees for application of the systems in a residential building

Percentage	Total project costs [€]				Water price [€/m ³]
	EoP	BWL + GWL	BWL + GWP	BWL + EoP	
108.4623%	8,210,353	3,714,483	3,714,483	7,408,056	1.65

Table 14-47: Intersection points resulting from the sensitivity analysis regarding varying waste water fees for application of the systems in a residential building

Percentage	Total project costs [€]				Waste water fee [€/m ³]
	EoP	BWL + GWL	BWL + GWP	BWL + EoP	
5.5424%	3,632,340	3,707,235	3,632,340	4,034,783	0.14
7.1692%	3,707,235	3,707,235	3,632,340	4,089,970	0.18
38.7614%	5,161,627	3,707,235	3,632,340	5,161,627	1.00

Table 14-48: Intersection points resulting from the sensitivity analysis regarding varying drinking and waste water fees for application of the systems in a residential building

Percentage	Total project costs [€]				Water price [€/m ³]	Waste water fee [€/m ³]
	EoP	BWL + GWL	BWL + GWP	BWL + EoP		
18.4019%	2,011,219	3,637,347	2,840,274	2,840,274	0.28	0.47
31.4677%	2,967,103	3,648,538	2,967,103	3,544,609	0.48	0.81
33.4268%	3,110,427	3,650,216	2,986,120	3,650,216	0.51	0.86
40.8926%	3,656,610	3,656,610	3,058,589	4,052,667	0.62	1.06
61.4645%	5,161,625	3,674,230	3,258,279	5,161,625	0.93	1.59
108.4623%	8,599,927	3,714,483	3,714,483	7,695,111	1.65	2.80

Table 14-49: Intersection points resulting from the sensitivity analysis regarding a varying energy price (constant water fees) for application of the systems in a residential building

Percentage	Total project costs [€]				Energy price [€/kWh]
	EoP	BWL + GWL	BWL + GWP	BWL + EoP	
90.6442%	7,941,999	3,575,733	3,575,733	7,199,380	0.13
459.3725%	9,472,645	8,758,445	5,806,702	8,758,445	0.68
531.4811%	9,771,978	9,771,978	6,242,991	9,063,336	0.78
2079.2345%	16,196,934	31,526,643	15,607,581	15,607,581	3.07
2389.5360%	17,485,042	35,888,129	17,485,042	16,919,605	3.53
9725.9500%	47,939,591	139,006,125	61,873,579	47,939,591	14.36

Table 14-50: Intersection points resulting from the sensitivity analysis regarding a varying energy price with direct effect on water fees and contamination related water fees for application of the systems in a residential building

Percentage	Total project costs [€]				Water price [€/m ³]	Waste water fee [€/m ³]	Energy price [€/kWh]
	EoP	BWL + GWL	BWL + GWP	BWL + EoP			
90.4003%	9,702,464	3,572,116	3,572,116	8,496,280	1.52	3.57	0.13
680.9993%	13,364,052	11,884,986	7,277,230	11,884,986	1.72	4.04	1.01
868.8045%	14,528,405	14,528,405	8,455,423	12,962,565	1.79	4.19	1.28
9281.7470%	66,686,864	132,943,267	61,233,885	61,233,885	4.73	10.91	13.70
83274.3300%	525,425,183	1,174,412,592	525,425,183	485,784,468	30.57	70.02	122.91

Table 14-51: Intersection points resulting from the sensitivity analysis regarding varying energy, drinking water and waste water fees for application of the systems in a residential building

Percentage	Total project costs [€]				Water price [€/m ³]	Waste water fee [€/m ³]	Energy price [€/kWh]
	EoP	BWL + GWL	BWL + GWP	BWL + EoP			
14.8931%	1,401,235	2,438,110	2,291,281	2,291,281	0.23	0.38	0.02
18.2902%	1,663,862	2,488,768	2,344,810	2,488,768	0.28	0.47	0.03
29.3531%	2,519,131	2,653,739	2,519,131	3,131,904	0.45	0.76	0.04
31.5103%	2,685,908	2,685,908	2,553,124	3,257,316	0.48	0.81	0.05
61.3096%	4,989,686	3,130,279	3,022,682	4,989,686	0.93	1.58	0.09
188.6100%	14,831,264	5,028,599	5,028,599	12,390,250	2.87	4.87	0.28

Table 14-52: Intersection points resulting from the sensitivity analysis regarding a varying surcharge for engineering etc for application of the systems in a residential building

Percentage	Total project costs [€]			
	EoP	BWL + GWL	BWL + GWP	BWL + EoP
249.2585%	7,980,836	4,988,084	4,862,672	7,980,836
598.0066%	7,980,836	7,980,836	7,737,388	9,714,308
627.5406%	7,980,836	8,234,279	7,980,836	9,861,109
1078.0790%	7,980,836	12,100,535	11,694,606	12,100,535
1202.1252%	7,980,836	13,165,027	12,717,114	12,717,114

CV

Personal data

Name: Björn Lindner
Date of birth: 03.06.1974
Place of birth: Hamburg, Germany
Address: Suttnerstrasse 25
22765 Hamburg
Phone: +49 / 40 / 81 35 01
E-mail: b.lindner@tuhh.de

Work experience

- Since 05.2006 Work as consultant for the company AEROTEC Engineering GmbH
- During May: Internal training on CAD and data management tools
 - Since June of 2006 work on behalf of Airbus Germany: Coordinator of Airbus R&D projects with responsibilities for Germany, France, England and Spain and support for internal processes
- 06.2001 – 04.2006 Scientific employee at the institute of wastewater management and water protection of the Hamburg University of Technology (TUHH)
- Work on black water loop system investigation and development
 - Planning and coordination of an advanced training program of 3 ½ months for engineers of 9 different countries
 - Performance of projects and elaboration of expertises in the working field of decentralized wastewater treatment
 - Work as tutor for environmental engineering students in the international program of study of the Northern Institute of Technology (NIT)
 - Supervision of project works and Master and Diploma theses
 - Elaboration of tenders for lab and engineering services
 - Support in the elaboration of a proposal for EU funding
- 09.1996 – 05.2001 Student assistant in the engineering office Bauinstitut Hamburg-Harburg (BIHH)
Assessment of the technical construction of buildings and estimation of the refurbishment needs, generation of drawings, bills, and tenders

Tertiary education

10.1994 – 05.2001 Program of study: Civil and environmental engineering at the Hamburg University of Technology (TUHH)
In-depth studies in water and waste treatment, concrete construction, and steel construction
Degree: Diploma

School education

08.1985 - 06.1994 Gymnasium Osdorf, Hamburg, Degree: Abitur (university-entrance diploma)
07.1981 - 07.1985 Elementary school Musäusstrasse, Hamburg

Language skills

English, Spanish