

# The SOIL Guide to Ecological Sanitation©

*First Edition, February 2011*



## **A Word of Warning**

EcoSan is a cyclical process moving from sanitation to treatment to reuse. Focusing on only the sanitation aspect of EcoSan can be dangerous and is certainly irresponsible. We encourage those developing EcoSan initiative to think carefully about all steps of the process before constructing toilets. SOIL offers consultancy services in waste treatment on a case-by-case basis and if you have any questions please contact [info@oursoil.org](mailto:info@oursoil.org).



## Compost Operations<sup>1</sup>

### Introductory Notes

1. This section concerns the composting of poop from SOIL UD toilets, i.e. there is a very low quantity of urine arriving at the compost site. For compost sites which compost poop and urine combined, different operational measures may be necessary.
2. This section does not cover the handling of urine on its own, nor does it cover nutrient capture from urine.
3. This section does not address the agricultural use of compost, the creation of experimental gardens at the compost site, or ecological toilets. Other documents in this guide will address these issues.
4. Prior to the cholera epidemic of 2010, SOIL was simultaneously operating three compost sites in different communes of Port-au-Prince. This operation was in-line with our goal of sustainable composting through decentralized community compost sites. After the cholera epidemic of 2010, we restructured our compost activities into one single site, located in Pernier, Port-au-Prince.
5. At the time of going to print, the Pernier compost site receives up to 5,000 gallons of human waste per week.
6. This section draws on our experience at Pernier; operations described are those that occur in Pernier; and reference photos are exclusively from Pernier. The size of the compost site facilities (e.g. size of drum cleaning zone) and quantity of operations materials (e.g. amount of cleaning materials, number of compost operatives) will depend upon the quantity of poop received at the compost site. This should be well considered when designing a composting operation.

### Section Objectives

1. To provide the reader with instructions, guidelines, best practices and SOIL experiences, on the operation and management of a compost site for treating human wastes.

---

<sup>1</sup> This operations guide is specifically for an offsite compost facility receiving high volumes of human wastes, though the principles described can be adapted to any system.

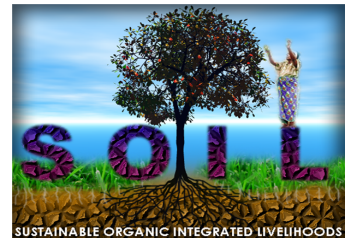



- To provide the reader with a part of the SOIL Guide to EcoSan, which if studied thoroughly, provides a complete package of information and instructions on how to implement a successful EcoSan project.

## The Compost Cycle

The compost cycle defines the various stages, processes and physical requirements for composting: from receiving the poop at the compost site to arriving at finished compost. The type of compost cycle is determined by the following three main factors:

- The volume of poop arriving at the compost site.
- The area of land available for composting.
- The area of land available for storing the finished compost.

The SOIL compost cycle at Pernier has 2 steps, described below:

'Phase 1' or 'Controlled' Composting	'Phase 2' or 'Windrow' Composting
Duration: 2 months	Duration: 4-6 months
Purpose: <i>To kill all pathogens in the compost in a safe and controlled environment.</i>	Purpose: <i>To decompose the compost in an environment which requires less control and less infrastructure thereby increasing the capacity of the phase 1 structure.</i>
	
Notes: The 2-month composting period for phase 1 composting begins when the last drum is dumped in the compost pile. Therefore, the majority of compost in the compost structure will have been	Notes: The 6-month composting period required to arrive at a well-decomposed, useful compost, is based on SOIL's experience in Cap-Haitien. It is not, however, a 'golden rule' which all humanure composters



composting for more than 2 months. Because of the risks involved in phase 1 composting, it is highly advisable that a period of at least 2 months is respected.	must obey.
---	------------

## Phase 1 Composting or Controlled Composting

This section addresses composting operations using the SOIL compost structure at Pernier. However, the principals described will be relevant to other compost structures.

### Phase 1, Step 1: Preparing the compost structure (Reference photos: K201)

The compost structure is lined with 150 mm/6" of bagas<sup>2</sup>. This lining is in the 4 sides of the compost structure and on the concrete floor, creating a 'bagas carpet'. This preparation is necessary to ensure that there is a layer of organic material around the edges of the pile which will insulate the compost within the bin so that the entire pile can reach thermophilic conditions.

### Phase 1, Step 2: Building the compost pile (Reference photos: K202, K203)

The 15 gallon poop drums are emptied onto the 'bagas carpet' one by one. After emptying three poop drums, a single drum of bagas is emptied onto the poop, ensuring the entire area of poop is covered. The ratio of 3:1<sup>3</sup> is important; using too much bagas will dry out the compost pile; and using too little bagas will not cover the poop and will attract flies and create odour. The process of emptying drums and covering with bagas continues until all the drums are emptied, or the compost structure is full. Step 2 may take days, weeks, months or even years depending upon the quantity of poop received at the compost site.

### Phase 1, Step 3: Finishing the compost pile (Reference photos: K204a, K204b)

The compost structure should be filled to the top of the walls with the 3:1 ratio

<sup>2</sup> Bagas is the tried and tested carbon source for SOIL's composting operations in Haiti, other carbon sources are available and may be used. SOIL also tried using wood chips, but they did not decompose rapidly enough by thermophilic composting.

<sup>3</sup> The ration 3:1 is an empirical ratio, based on SOIL's experience with the Pernier compost structure.

# The SOIL Guide to Ecological Sanitation©

First Edition, February 2011



of poop to bagas. Finally, a 6-inch 'bagas lid' should cover the entire area, creating a mound on top. With gravity, the compost pile will very quickly compact and the top level of the compost pile will decrease. The compost pile represents a very attractive meal for flies, rodents, chickens and other pests. The bagas lid will deter flies, but additional security is required against other pests. The entire surface area of the compost pile is covered using chicken wire once the compost pile is finished *AND ALSO* after each drum emptying operation.

## Phase 1, Step 4: Managing the leachate, or 'jikaka' (Reference photos: K204c)

Poop can be very wet. Even when mixed with bagas in the SOIL UD toilets, the poop arriving at the compost site can often be more liquid than solid. As such, after each incremental filling of the compost structure (step 2), and after the final filling of the compost structure (step 3), there will be a quantity of leachate, or 'jikaka' coming from the drains, that requires management. The compost structure at Pernier collects jikaka from two compost compartments in a 15 gallon drum. When the drum is half full, the compost site supervisor empties it using a smaller bucket, and empties this bucket into *the center* of the compost pile.

The quantity of jikaka varies greatly, and so does its management. The compost supervisor must closely monitor the rate of filling of each 15 gallon drum and be ready to empty them when they are half full. Having a well-defined 'emptying schedule' with times of emptying may be necessary for large compost sites<sup>4</sup>.

Covering the compost pile with a roof is essential or the quantity of jikaka coming out of the leachate drains will be too great to manage.

## Phase 1, Step 5: Compost pile monitoring (Reference photos: K204d)

The compost pile must be monitored for temperature using a compost pile thermometer to ensure that thermophilic composting is taking place. The three compost pile objectives: oxygen, humidity, and C/N ratio, can also be monitored using more advanced tools, but these are not

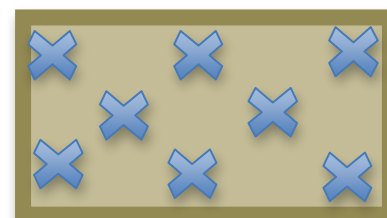

<sup>4</sup> The SOIL compost site in Port-au-Prince empties approximately 25gallons of jikaka per compost compartment per day at the beginning of phase 1 composting, and 1gallon jikaka per compost compartment per day at the end of phase 1 composting.

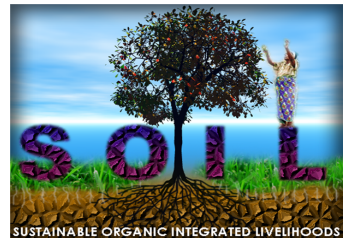

currently monitored by SOIL in Haiti. It is important to measure temperatures throughout the compost pile. SOIL measures temperature in eight locations in each compost compartment, in the positions indicated by crosses in the adjacent diagram.

Temperature monitoring for each compost compartment occurs every two days, and occurs in the morning before the daily maximum ambient temperature. Temperature is logged in a notebook onsite, and transferred to a computer at the office where the information can be displayed graphically.

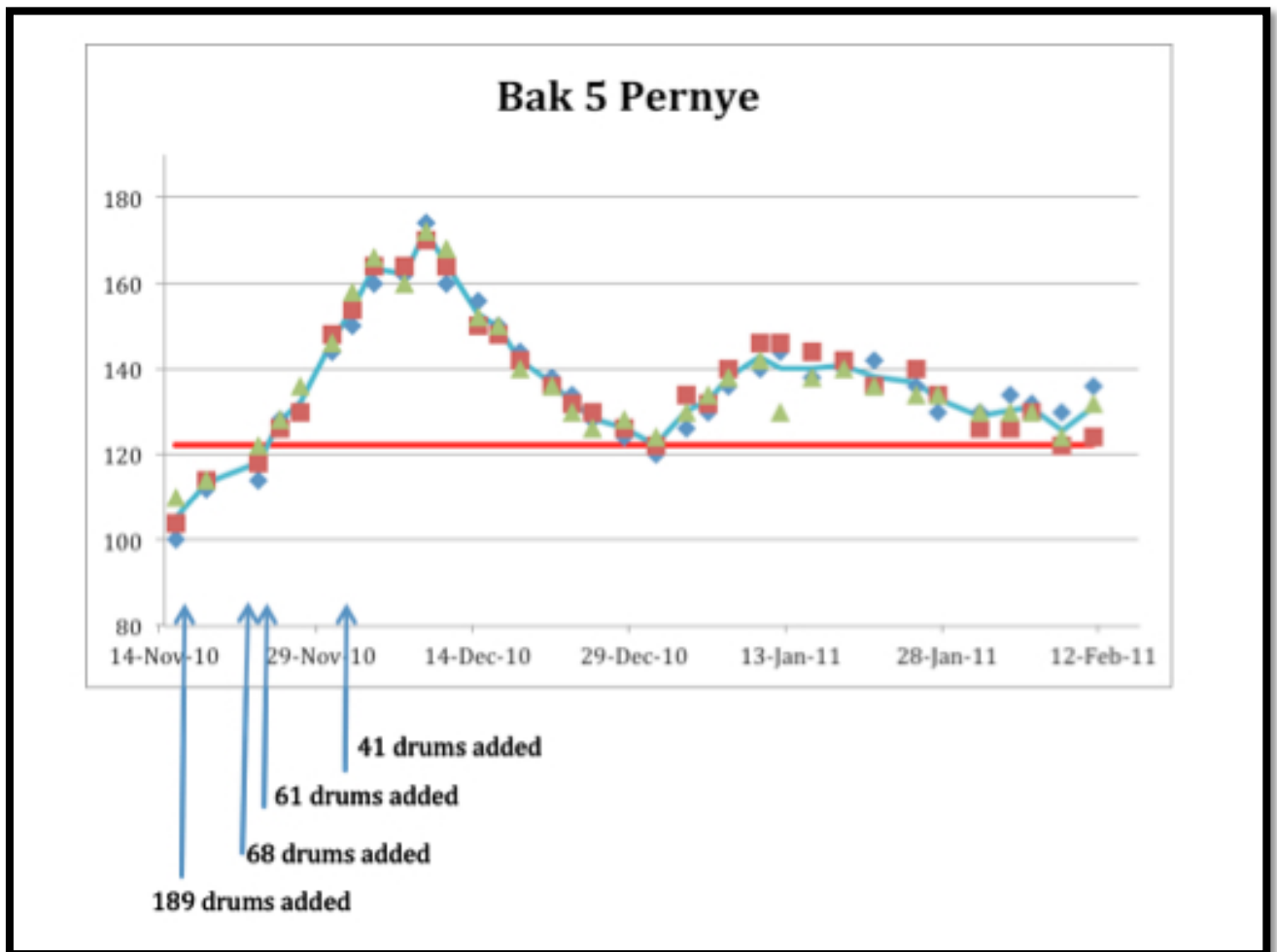

## Phase 2 Composting or Windrow Composting

Phase 2, Step 1: Emptying the compost structure  
(Reference photos: K212, K213a,b,c)

The SOIL compost structure at Pernier has been designed so that each of the six compost compartments can be individually accessed for compost removal

# The SOIL Guide to Ecological Sanitation©

*First Edition, February 2011*



at the end of phase 1 composting. Accessing the compost pile requires:

- Detaching the front pallet walls in order to access the compost.
- Detaching the internal walls during the compost removal process.

With skilled labour and careful supervision, it should be possible to remove the compost without further damage to the compost structure.

At the end of phase 1 composting, once most of the air and liquid has left the compost pile and the solid matter has been compressed by gravity, the volume reduction of the compost pile is 40%-80% (Jenkins, 2005). This compaction means that the walls no longer support the compost pile and the pile will not slump once the pallet walls are removed.

The degree of compaction means that the compost pile is now much more dense than before, and very difficult to move. Moving the pile with manual labour takes a long time, a lot of effort and can be very expensive. Wherever possible, a mechanical excavator should be employed to remove the compost from the compost structure.

Phase 2, Step 2: Forming the windrows (size, orientation)  
(Reference photos: K214a,b,c, K215, K216)

The compost is removed from the compost structure mechanically and stored in windrows. Ideally, the windrows will be located on the same compost site, and not too far from the compost structure. The size of the windrows will depend upon the area of land available, and the quantity of Phase 2 compost, but generally windrows are longer than they are wide, and less than 1.5m tall.

SOIL windrow dimensions are: Length = 50m. Width = 4m. Height = 1.30m.

It should be noted that at the time of release of this first edition, SOIL has limited experience of windrow composting. But here are some general considerations that we have learned from our own research:

## *Turning*

Turning the windrows is generally recommended to accelerate the decomposition process. Turning redistributes oxygen, moisture, and heat, in order to create a homogenous compost pile. However; turning is expensive in terms of labour or machinery; and requires additional land space. Turning is not necessary if a Phase 2 composting time of six months is accepted. If faster decomposition is required, say four months, then turning would prove

# The SOIL Guide to Ecological Sanitation©

*First Edition, February 2011*



beneficial.

## *Storage, rainwater protection and drainage*

Because the composting windrows no longer contain pathogens, they can be stored on bare earth and do not pose a public health risk. The windrows will benefit from light showers, but heavy downpours will wash away the nutrients and lessen the agricultural potential of the compost. There are many options available to prevent the windrows from suffering heavy nutrient loss but the most relevant options for Haiti are presented here:

1. Cover the windrows with plastic sheeting and provide drainage channels at the base of the windrows.
2. Do NOT cover the windrows with plastic sheeting or provide drainage channels at the base of the windrows. Instead make the drainage channels run to a basin filled with bagas. The bagas will absorb the run-off from the windrows and is later returned to the windrows.

SOIL uses option 2, above, in order to avoid the labour intensive activity of covering and uncovering plastic sheeting.

## *Access*

Allowance must be made to access the windrows in order to form them at the beginning of the Phase 2 period, and to remove the compost at the end of the Phase 2 period. The access requirements will be determined by the volume of compost generated and the machinery used for transporting the compost.

## **Drum Operations**

### Offloading & stocking of poop drums (Reference photos: K205a)

The poop drums are heavy. They can be up to 50 kg if they contain a high volume of urine. As such, the poop drums should be offloaded from the drum truck and stored adjacent to the location where they will be emptied, to avoid time-consuming double-handling of the poop drums prior to emptying them in the compost structure. It is advisable that 15 gallon poop drums are ALWAYS lifted by 2 people; never lifted alone.

### Positioning the drums inside the compost structure (Reference photos: K205b)



# The SOIL Guide to Ecological Sanitation©

First Edition, February 2011



Stairs are provided at the compost site to lift the poop drums up and over the walls of the compost structure. The drums are positioned inside the structure prior to being dumped.

## Emptying/dumping the poop drums

(Reference photos: K202)

Poop drums are emptied and the compost pile is built as described on the section on 'Phase 1' composting. To upend and empty the poop drums requires a sudden, vigorous action which may strain the backs of the compost operatives if they do not warm up and lift properly.

Drum dumping should be the only activity at the compost site which creates a smell. If the compost site has neighbours, and a strong wind to carry the smell to these neighbours, then the compost operation will not be popular with the local community. Community acceptance is essential for the good function of the compost site. For this reason, drum dumping occurs in the early morning hours, as soon as there is enough light to operate safely.

Another reason to empty the drums in the early morning is so that the stigma associated with handling poop does not manifest itself in the form of offended neighbours, or abusive passers-by.

## Cleaning and disinfecting the poop drums and lids

(Reference photos: K206a,b. K207a,b,c. K208, K209)

Immediately after dumping, the poop drums and their lids are moved to a location adjacent to the drum cleaning zone, then cleaned and disinfected. The cleaning is very thorough, ensuring that:

- The drums are completely safe to return to the toilet operators who will be handling the drums at the toilet sites.
- The drums are visibly clean so that they are accepted by the toilet operators.

The drums and drum lids are cleaned according to the 5-step cleaning cycle:

Step	Activity	Equipment
Step 1	Clean drum	Bagas 'sponge'
Step 2	Rinse drum	Running water, ideally pressurised
Step 3	Scrub drum	Scrubbing brush, liquid soap
Step 4	Rinse drum	Running water, ideally pressurised

# The SOIL Guide to Ecological Sanitation©

First Edition, February 2011



Step 5	Disinfect drum	Chlorine sprayer, 1% chlorine solution
--------	----------------	--

The cleaning cycle occurs entirely on a special drum cleaning zone which also doubles as a carwash. The drum cleaning zone comprises:

- A sloping concrete slab with a central drainage channel and low block walls.
- A soak away into which drains ALL the liquid from the drum cleaning.
- A solids trap to catch all of the solid matter from the drum cleaning and stop it from entering and blocking the soak away (the solids trap requires regular cleaning or it will not function).
- An adjacent water source<sup>5</sup>.
- A roof to protect the drum cleaning operation from the sun and rain.

Water consumption during drum cleaning can be extremely high and should be monitored. Ultimately, water consumption will depend upon the availability of water: a drum cleaning zone with a tap from the local water supply network will use far more water than if the water is required to be trucked in from afar.

Water consumption for cleaning drums at the SOIL compost site is:  
2 gallons per 15 gallon drum.

The drum cleaning zone is a controlled space meant for drum cleaning, it is not meant for storage of dirty or clean drums. As soon as the drums are cleaned, they should be removed from the drum cleaning zone. It is necessary to control this by having a 'maximum drum rule' which sets the upper limit for the number of drums on the drum cleaning zone. At the SOIL compost site this maximum drum rule is: 20 drums.

## Onsite drum storage and management (Reference photos: K210, K211)

Up to 300 drums *daily* can be received, emptied, cleaned and stored at the SOIL compost site. The developed site does not have a large amount of free space and careful consideration is needed when storing the dirty drums, storing the clean drums, and moving the drums around the site.

After drum dumping the dirty drums are stored adjacent to the drum washing zone, ready for cleaning.

---

<sup>5</sup> The SOIL compost site has two 1000 gallon water tanks immediately adjacent to the drum washing zone.

# The SOIL Guide to Ecological Sanitation©

First Edition, February 2011



After the cleaning cycle, the drums and drum lids are stored in a controlled protected area away from; the drum cleaning zone; the compost structures; and away from any risk of re-contamination. The storage area should be in the shade, as the plastic drums and plastic drum lids will distort and/or crack with excessive sun exposure.

## General Compost Site Facilities

In addition to the facilities described above for Phase 1 and Phase 2 composting, and drum operations, the following site facilities should be included:

### Site security and site access

A humanure compost site should be secure, and unauthorized access by pedestrians, vehicles, or stray animals should not be permitted. The entire compost site should be closed off with a fence, or wall, that blocks all forms of unauthorized access. Access points for pedestrians or vehicles should be blocked with a gate.

### Signage

Signs should be present throughout the compost site to enforce site rules for both staff and visitors. Signs used in the SOIL compost site are shown in the table below:

Sign	Location of sign
'Respect the 20 drum rule!'	On drum cleaning zone
"Attention: No unauthorized access without permission of the site supervisor!"	At site entry
'Attention: All vehicles leaving site must disinfect tires!'	At site exit for vehicles
'Attention: All pedestrians leaving site must disinfect shoes and wash hands!'	At site exit for pedestrians
'Attention: No food to be consumed onsite!'	Multiple locations
'Attention: No smoking onsite!'	Multiple locations

# The SOIL Guide to Ecological Sanitation©

*First Edition, February 2011*



## Storage and control of materials (not including poop drums)

An onsite depot is required to store cleaning materials, miscellaneous construction materials, items of equipment, and other items. The depot should be secured and controlled by the site supervisor.

## Roads and drainage

The SOIL compost site receives a fair amount of traffic: pickups, water trucks, construction vehicles, as well as the thrice-weekly visit of the poop drum truck. There is, therefore, a well-compacted gravel road on the site. The site development at the SOIL compost site has stripped the land of all of its vegetation except for large mango trees. The rainwater which previously drained into the ground is now carried offsite by a drainage ditch. Road and drainage are necessary for a compost site if it is to be successfully managed during a Caribbean rainy season.

## Water supply

The greatest demand for water at the compost site is for drum cleaning. However, allowance should also be made for other water needs such as:

- Washing clothes and washing equipment
- Washing down vehicles on the carwash
- Gardening

The water need at the compost site should be properly assessed before planning any water supply or water storage infrastructure.

## Staff facilities

Work on the compost site is hard (involves heavy manual labour) and stigmatized. Every effort should be taken to provide comfortable staff facilities for the compost staff, including but not limited to:

- An individual changing room with a door for each staff member
- A shower
- A toilet
- A hand washing point
- A sanitary zone with table and chairs for resting and eating
- Potable drinking water

# The SOIL Guide to Ecological Sanitation©

*First Edition, February 2011*



## Hygiene infrastructure

*(Reference photos: K217, K218a,b, K219a,b,c)*

The SOIL compost site has the following hygiene infrastructure:

- A chlorine footbath (using 0.2% chlorine) for disinfecting the soles of shoes of all pedestrians leaving the site.
- A chlorine spray station with chlorine sprayer (using 0.2% chlorine), for disinfecting the surface of tires of vehicles leaving the site.
- A hand washing point (using 0.05% chlorine) at the site exit.
- A carwash (which doubles as a drum cleaning zone), with a motor-driven pressure sprayer, for spraying down and disinfecting vehicles which have been carrying the poop drums.
- Waste bins positioned around the site to collect all burnable waste, and a designated location to burn the waste.
- A chlorine reservoir containing 1.0% chlorine solution. This solution is prepared each Monday morning by the site supervisor using 70% HTH.

## Bagas storage area

A bagas storage area is simply a designated area for the storage of bagas used for Phase 1 composting. The bagas store should be located close to the compost structure(s) for ease of access by the compost operatives, and close to the main access road running through the site for convenient bagas delivery.

## **Health, Safety and the Environment**

### Site zoning

No unauthorized entry is permitted onto the SOIL compost site, which is divided into two zones:

- Clean zone, containing depot and staff facilities
- Dirty zone, for all composting operations and drum operations

A fence separates the two zones and all hygiene infrastructure is located between the two zones so that there is no contamination of the clean zone by pollutants from the dirty zone.

### Protection of soil, groundwater, and surfacewater

All SOIL compost site structures are designed so as to reduce or eliminate the risk of contamination of soil, groundwater and surface water. The most

# The SOIL Guide to Ecological Sanitation©

*First Edition, February 2011*



effective environmental protective measure is to choose a compost site location away from surface water sources and high above the groundwater table.

The major risk of contamination on the compost site is accidental spilling of ji kaka. If this does happen during operations, the spill can be absorbed using bagas, which can then be returned to the most recent compost pile.

## Protection of staff

*The risk of exposure of faecal pathogens to compost staff is even greater than the exposure of faecal pathogens to the soil, groundwater and surface water.* Therefore, organizations operating compost sites have a duty to care for their employees and must provide, as a minimum, the following safety measures:

- Training and information on the risks associated with handling faecal matter.
- Training and information on the risks associated with heavy lifting and training on correct lifting techniques.
- Vaccinations for Hepatitis A, Hepatitis B, and Tetanus.
- Personal Protective Equipment (PPE) including: 2 sets of overalls, gloves, face masks.

## Protection of community members around the compost site

If all mitigation measures are properly implemented, then the risks associated with humanure composting remain within the confines of the compost site. Likewise, if the drum dumping activity is diplomatically scheduled, then the smells generated by drum dumping remain undetected by those outside the compost site.

However, there is often some degree of objection to humanure composting by community members adjacent to the site, or even by community members from further afield. The host community of the compost site should be informed of the composting operation and to the wider activities and objectives of ecological sanitation. Wherever possible, the host community should be involved in the composting operation itself, and be invited to inspect the site and observe the operation. Efforts should be made to ensure that the local community benefits as much as possible from the initiative, either through provision of toilets or compost or both.



## Technical Specification for Offsite Composting Facility

### Section Objectives

1. To provide the reader with a technical specification, to be used in conjunction with the drawings and photos in this guide, to construct a SOIL structure developed at Pernier.
2. To provide the reader with some background to the development of the SOIL compost structures, by including as footnotes, information on previous designs and lessons learned.
3. To provide the reader with a part of the SOIL Guide to EcoSan, which if studied completely, provides a complete package of information and instructions on how to implement a successful EcoSan project

### Technical Specification

This technical specification is for the 10th version (Mk.X) of compost structure used by SOIL in Haiti. With each filling and emptying of the compost structure, we have learned new lessons and improved upon the design of the structure. We expect this evolution to continue. With the current projected turnover of compost at our site in Port-au-Prince, we expect to arrive at the Mk.XV within a year of publishing this first edition of The SOIL Guide.

Photos K1 to K10 in the compost photos document show the evolution of the SOIL compost structure, from Mk.I to Mk.X.

Ref	Specification	Reference Documents.
4.1	CONCRETE BASE, BLOCK WALLS & DRAINAGE	
4.1.1	CONCRETE BASE	
	<p>The Mk.X SOIL compost structure uses a concrete base, low level block walls, and a drainage channel:</p> <ol style="list-style-type: none"> <li>1. To contain all liquids and solids within the compost pile and not waste any material.</li> <li>2. To protect the environment (i.e. soil, surface water, and groundwater) from pollution.</li> </ol>	PHOTO K101



Ref	Specification	Reference Documents.
	<p>Concrete is an ideal material to use as a base:</p> <ol style="list-style-type: none"> <li>1. Durability: A well-formed and well-cured concrete base has a design life of 10 years without requiring significant repairs. Importantly, this means that no remedial works are required after each turnover of compost.</li> <li>2. Forming: The base can be sloped towards the leachate drain, with a controlled gradient.</li> </ol>	
	<p>The concrete base must bear the load of the compost as well as additional loads from compost operatives working in the structure and full 15 gallon poop drums resting on the base.</p> <p>The required load bearing capacity of the concrete base demands a concrete thickness of at least 100mm.</p>	
	<p>A gravel:sand:cement mix of 4:2:1 is used for the concrete base.</p>	
	<p>The gradient of the concrete base must allow for drainage of liquids to the leachate drain. The Mk.X has a slope of 75mm in 6000mm, or 1.25%, or 1:80<sup>1</sup>.</p> <p>Therefore, the thickness of the concrete base of the Mk.X is 175mm sloping to 100mm.</p>	<p>Dwg. K1</p>
	<p>A high quality finish ('cirage') to the concrete surface is required so that it remains impermeable over its design life.</p> <p>A sand:cement mix of 2:1 is used for the</p>	<p>PHOTO K102</p>

<sup>1</sup> Earlier models had a shallower gradient and were both difficult to form and did not drain the leachate successfully.





Ref	Specification	Reference Documents.
	<p>cirage. The sand used must be fine sand, sieved.</p>	
	<p>The wooden columns that provide the structural strength for the external and internal walls, as well as the roof supports, are cast into the concrete base.</p> <p>Prior to casting the columns, they are protected by the application of a triple coat of protective wood paint.</p>	<p>Dwg. K1 PHOTO K103</p>
4.1.2	<b>BLOCK WALLS</b>	
	<p>The poop / cover material mix that is dumped into the compost structure has a physical characteristic like a liquid; rather like a congealed wet cereal. This physical characteristic affects the design of the structural elements, the drainage; and determines the manageable surface area for the compost pile.</p>	
	<p>The Mk.X is compartmentalized into 6 units by the low level block walls.</p> <p><b>Compartmentalisation</b> is necessary for the operability of the Mk.X.<sup>2</sup></p> <p>Each of the 6 units in the Mk.X has a surface area of 12.5m<sup>2</sup> (5m * 2.5m). This is a manageable area for building a humanure compost pile.</p>	<p>Dwg.K2 PHOTO K104</p>
	<p>The block walls at base level are an essential part of the drainage system of the compost piles. They contain the leachate and direct it to the drainpipe at the corner of the compost structure. The block walls must be mounted atop the concrete base with a very good seal.</p>	<p>PHOTO K105 PHOTO K106 PHOTO K107</p>

<sup>2</sup> Earlier models that were not compartmentalised and had large areas made operations (dumping of drums and building of the compost pile) very difficult.



Ref	Specification	Reference Documents.
	<p>If the seal is not fit for purpose then the leachate will leak between the blocks and the concrete base. A good seal is achieved by:</p> <ol style="list-style-type: none"> <li>1. Scabbling the surface of the concrete base as it begins to cure, thus providing a rough surface on which to mount the blocks, and a greater bond between the concrete base and the mortar for the blocks.</li> <li>2. Using a sand:cement mix of 2:1 for the mortar, and using a large volume of this mortar on the insides of the block walls.</li> </ol> <p>The blocks are sand-cement permeable blocks. The entire exposed surface area of the blocks requires rendering after mounting on the mortar.</p>	
	<p>After mounting the blocks on the concrete slab, a triangular area of benching (1m by 2.5m) is formed which directs the ji kaka towards the leachate drain. The benching requires the same sand:cement mix as the cirage on the concrete base, 2:1.</p>	<p>Dwg. K2 Dwg. K6</p>
4.1.3	<b>LEACHATE DRAIN</b>	
	<p>A short length (400mm) of 4" PVC pipe in the corner of each compost compartment drains the leachate from each compost pile. All the ji kaka from the compost pile will concentrate at this point and so it is here that the structure is most likely to leak. Very careful supervision is needed when installing the drainpipe and forming the mortar around it.</p>	<p>Dwg.K3 Dwg.K7 PHOTO K110</p>
	<p>A fine aluminium mesh fit over the end of the 4" PVC pipe on the <i>inside</i> of the compost structure prevents solids from leaving the compost pile in the leachate stream.</p>	<p>Dwg.K7</p>



Ref	Specification	Reference Documents.
	The leachate is very nutrient rich and should be returned to the top of the compost pile after it has drained out. A 15 gallon drum cast into the concrete base collects the leachate from two compartments and stores it until it is returned to the compost pile by the compost site supervisor.	Dwg.K7 PHOTO K108 PHOTO K109
4.2	WALLS	
4.2.1	EXTERIOR WALLS	
	The exterior walls are constructed from pallets (standard pallet dimensions are 1,20m wide by 1,00m high) braced with a single band of lattes around the middle, and with 400mm long segments of lattes at the top and bottom of each pallet junction.	Dwg.K3, K4, K5, K6. PHOTO K111
	The compost pile generates significant horizontal, outward pressure on the exterior walls. This pressure can easily distort the exterior walls if they are not effectively braced using the lateral support provided by the interior walls.	
	The inside of the exterior walls are lined with chicken wire.	
4.2.2	INTERIOR WALLS	
	Interior walls (not considering the blocks at base level) are constructed using: 1. Wooden slats <sup>3</sup> or 'lattes' (to provide lateral support to the exterior walls and to support the chicken wire). 2. Chicken wire (to hold in place the bagas). 3. Bagas infill.	Dwg.K6 PHOTO K112
	Interior walls are supported by the low level	

<sup>3</sup> Earlier models used 'planches' instead of 'lattes' to provide more structural strength. However, the strength in the 'lattes' is sufficient for the purpose intended and 'lattes' are less expensive than 'planches'.



Ref	Specification	Reference Documents.
	block wall, and as such, the width of the interior walls matches the width of these blocks, i.e. 15cm.	
	A much more durable (but also more expensive) material to use instead of chicken wire is a steel grill, 'grille metallique'.	
	The interior walls distort (degree of distortion will depend upon quality of construction) with the pressure exerted by the growing compost pile. For the interior walls to be effective holders of bagas, the walls should be filled with bagas BEFORE the compost structure is commissioned for use, i.e. before drum dumping begins.	PHOTO K113
4.3	ROOF	
	The main objective of the roof is to protect the compost pile from rain. It should be a permanent structure, high enough to provide aeration to the surface of the pile and to not obstruct composting operations, yet low enough to minimize wind-generated negative air pressures which would cause roof damage.	
	The Mk.X roof is constructed using a frame of wooden lattes, covered by toles. The roof is mounted on the 21 no. wooden 2*4 columns.	Dwg.K5 PHOTO K114, K115
	<p>The cheapest and simplest possible roof structure; a plastic tarpaulin covering the compost pile, is not recommended because:</p> <ol style="list-style-type: none"> <li>1. The tarp does not allow for aeration of the top surface of the compost pile.</li> <li>2. The tarp is difficult to support and will yield under the weight of rainwater, making it very difficult to channel rainwater off its surface.</li> <li>3. The tarp is removable according to the</li> </ol>	PHOTO K6c



Ref	Specification	Reference Documents.
	weather and the compost operations. I.e. ON during rain and during nights and OFF during dry spells in the daytime. This is a labour intensive operation that requires supervision.	
4.4	<b>ACCESS BY COMPOST OPERATIVES</b>	
	A 50cm wide walkway around the front and sides of the compost structure facilitates safe composting operations by providing a safe platform from which to enter inside the compost structure, or to inspect the compost piles from the outside.	Dwg. K1 PHOTO K116
4.5	<b>MAINTENANCE</b>	
	The SOIL Mk.X compost structure has not been operated for a sufficient length of time for to give a comprehensive and thorough schedule of maintenance requirements. However, it can be stated that up until the date of issue of this edition of The Guide, the most common failure of the structure is leaking of ji kaka though the block walls, and therefore the most common maintenance requirement is cement rendering of patches of the block walls which are leaking.	PHOTO K117, K118, K119
	<p>It is anticipated that with each emptying of the compost structure, the following maintenance will be required before the structure can be re-filled:</p> <ul style="list-style-type: none"> <li>• Rendering of the 'cirage' on the block walls.</li> <li>• Realignment of the exterior pallet walls.</li> <li>• Tightening of the wooden slats which support the internal and external walls.</li> <li>• Replacement of the chicken wire used for the internal wall.</li> </ul>	

# The SOIL Guide to Ecological Sanitation©

First Edition, February 2011



Ref	Specification	Reference Documents.
	<p>The above list is not exhaustive and there may well be other maintenance requirements which will be a function of:</p> <ul style="list-style-type: none"><li>• The quality and durability of the materials used.</li><li>• The quality of workmanship during construction.</li><li>• The care taken when operating the structure; filling and emptying with compost.</li></ul>	



## List of Drawings: SOIL Compost Structure Mk.X

Drawing no.	Drawing Title	Drawing Creation Date	Revision
K1	Plan on concrete base	30th Jan. 2011	-
K2	Plan on block walls	30th Jan. 2011	-
K3	Walls detail	30th Jan. 2011	-
K4	Long section	30th Jan. 2011	-
K5	Short section	30th Jan. 2011	-
K6	Zoom on long section	30th Jan. 2011	-
K7	Leachate drain detail	30th Jan. 2011	-

### Notes on Drawings:

1. All dimensions are given in mm, unless otherwise stated.







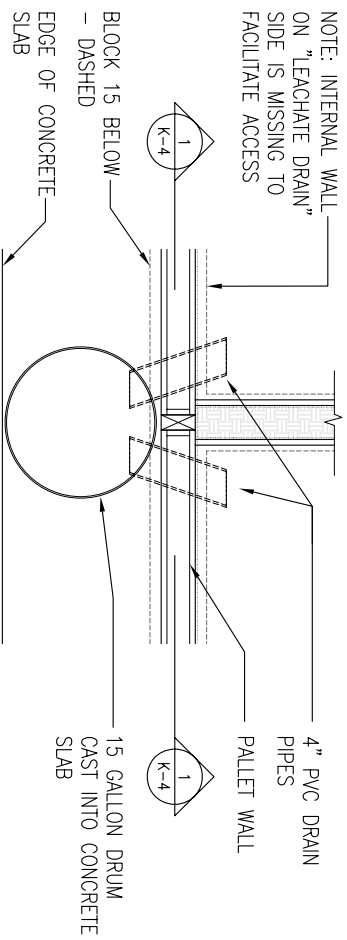
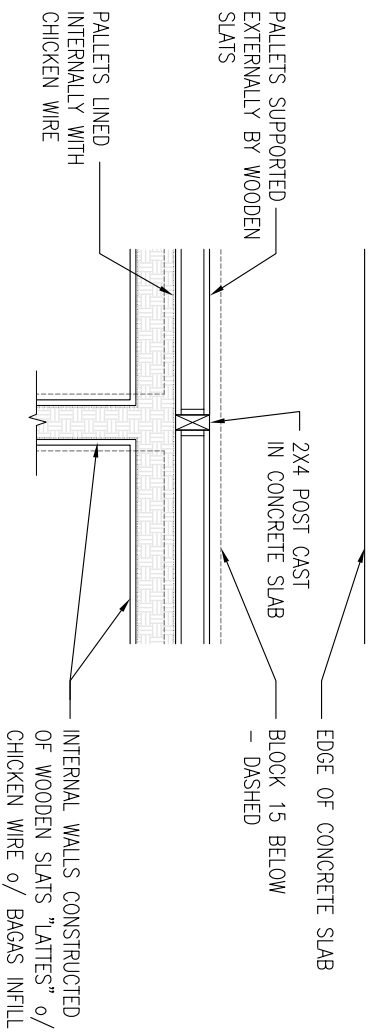

Travail/ Project

### SOIL Compost Structure

### Planview Wall Detail

Revisions / Revisions		Date	no.	Drawing Creation date	Project #	Drawing #
				30th Jan. 2011		K-3
				Echelle/ scale		
				1.20		
				Ingenieur de conception/ Design Engineer		
				Anthony Kilbride, SOIL		
				Etabli/ Drawn		
				Hill Pierce, Noreen Shinohara, Architecture for Humanity		



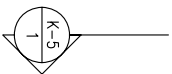
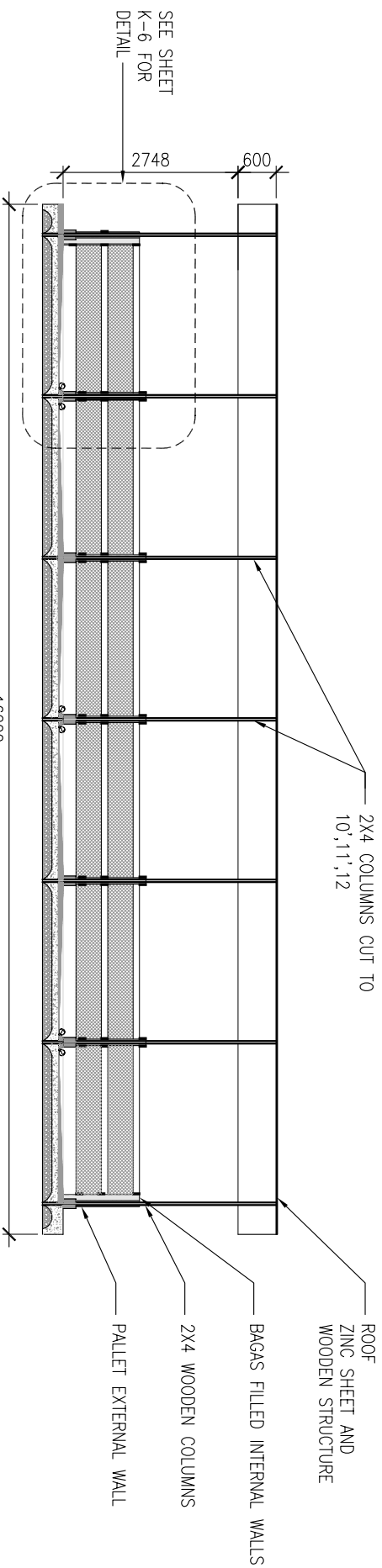
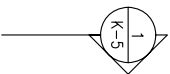

Travail/ Project

# SOIL Compost Structure

## Long Section

Revisions / Revisions		Date	no.	Drawing Creation date	Project #	Drawing #
				30th Jan. 2011		K-4
				Echelle/ scale		
				<b>1:100</b>		
				Ingenieur de conception/ Design Engineer		
				Anthony Kilbride, SOIL		
				Etabl/ Drawn		
				Hill Pierce, Noreen Shinohara, Architecture for Humanity		



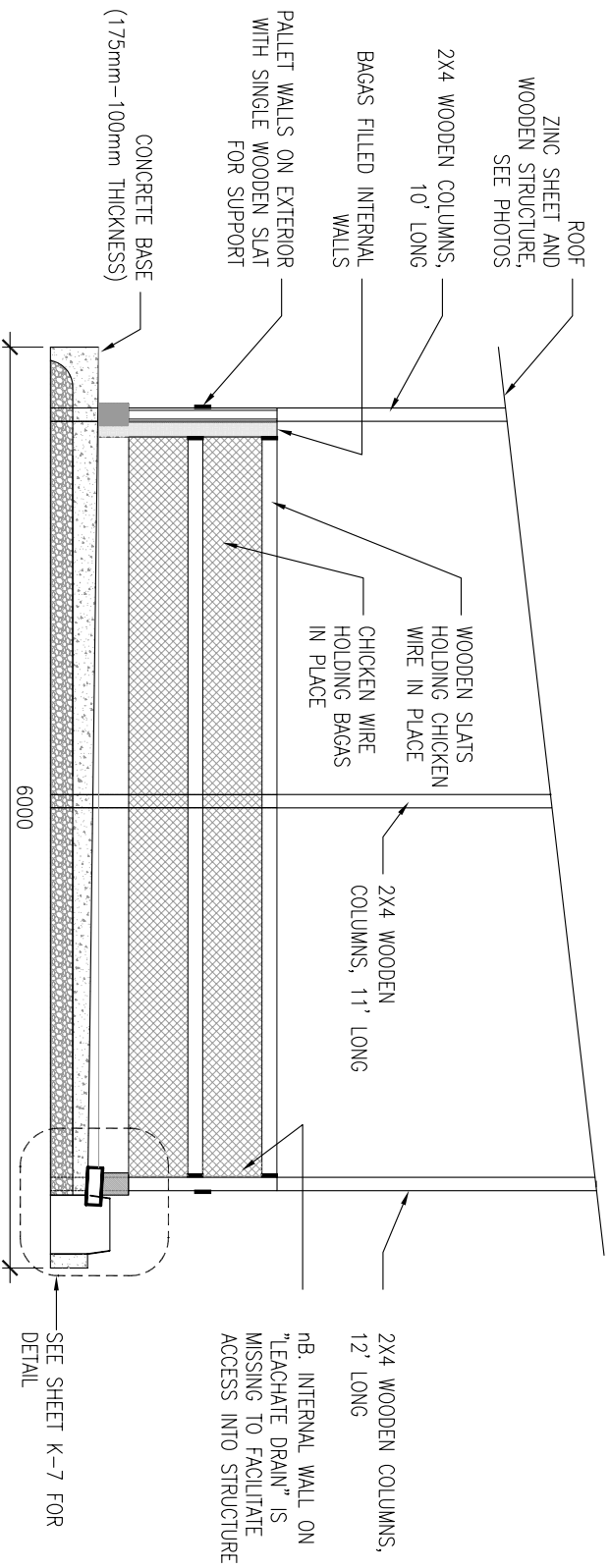

Travail/ Project

# SOIL Compost Structure

Revisions / Revisions	Date	no.	Drawing Creation date	Project #	Drawing #
			30th Jan. 2011		K-5

Echelle/ scale  
**1:50**

Ingenieur de conception/ Design Engineer  
Anthony Kilbride, SOIL

Établ/ Drawn  
Hill Pierce, Noreen Shinohara, Architecture for Humanity

