

**MINISTRY OF WATER, LANDS AND ENVIRONMENT**

**DIRECTORATE OF WATER DEVELOPMENT**

**SOUTH WESTERN TOWNS WATER AND  
SANITATION PROJECT**

**UGANDA – AUSTRIA**

**ECOLOGICAL SANITATION**

---

**DESIGN AND  
CONSTRUCTION**

JUNE 2003

---

## TABLE OF CONTENTS

<b>1</b>	<b>INTRODUCTION .....</b>	<b>1</b>
1.1	Conventional Excreta Disposal Systems .....	1
1.1.1	The Drop and Store Systems of Sanitation .....	1
1.1.2	Flush and Discharge (Water Bourne Sanitation Systems) .....	1
1.1.3	Summary of Disadvantages of Conventional Systems of Sanitation .....	2
1.2	Ecological Sanitation systems .....	2
1.2.1	Objectives of Eco-san .....	2
<b>2</b>	<b>DESIGNING AN ECOSAN TOILET.....</b>	<b>3</b>
2.1	Ecosan as a System .....	3
2.2	Ecosan Toilet Components.....	4
2.3	Types of Ecological Sanitation Toilet Systems.....	5
2.4	Products of Ecosan (Dehydration Toilet) .....	7
2.4.1	Urine .....	7
2.4.2	Faecal Matter .....	7
2.5	Other Design Options .....	8
2.5.1	Processing Vaults/Chambers.....	8
2.5.2	Anal cleaning Material.....	9
2.5.3	Absorbents and Bulking agents .....	9
2.5.4	Ventilation and Aeration.....	9
2.6	Sizing Vaults .....	10
<b>3</b>	<b>CONSTRUCTION OF THE ECO-SAN TOILET .....</b>	<b>11</b>
3.1	Choice of materials .....	11
3.2	Site Considerations.....	12
3.3	Other Considerations.....	12
3.4	Construction details for special consideration .....	12
3.5	Construction.....	12
3.5.1	Brick Masonry Dehydration Unit.....	12
3.5.2	Mud & Wattle Dehydration Unit.....	13
<b>4</b>	<b>OPERATION AND MAINTENANCE OF ECOSAN FACILITIES.....</b>	<b>14</b>
<b>5</b>	<b>MOST COMMON PROBLEMS.....</b>	<b>15</b>
	<b>APPENDIX .....</b>	<b>16</b>
	<b>Drawings.....</b>	<b>16</b>

---

---

## 1 INTRODUCTION

### 1.1 Conventional Excreta Disposal Systems

Traditionally, Sanitation has been handled in two common ways namely;

- Drop and Store (traditional pit latrines, VIP, e.t.c) and
- Flush and Discharge (Water borne sanitation systems)

#### 1.1.1 The Drop and Store Systems of Sanitation

- These are the most common in developing countries
- Require a lot of land as we keep shifting to a different site when its full
- Contaminates ground water resources as they are normally deep
- Does not work in areas that are densely populated, flooded, have soft soils or rocky
- This system above all, wastes the nutrient value that is found in the human excreta. Urine as a fertilizer has high N.P.K values while faeces are a very good soil conditioner

#### 1.1.2 Flush and Discharge (Water Bourne Sanitation Systems)

A human being, on average, annually produces about:

- 50Kgs (call it 50l) of faeces (potentially dangerous)
- 500l of urine (usually sterile), and
- 15,000 l of water (drinking water quality) is used to flush it away

This water could be put to other useful purposes. Even so, we have 50Kgs of potentially dangerous material, which we use to pollute thousands of litres of safe water. It is easier to handle faeces alone without mixing it with the water and urine. Disposing of the large volume of wastes resulting from the addition of water is difficult.

In cities, the liquid wastes are usually carried away by means of leaking sewers and discharged into water bodies after inadequate treatment while in most rural areas of the world, sewerage systems do not exist, and liquid wastes are conveniently discharged into the ground.

---

Since in such areas ground water is often tapped as a source of domestic water supply, there is an obvious need for proper planning and construction of the excreta disposal systems, with a full understanding of health hazards, economics and benefits involved.

### 1.1.3 Summary of Disadvantages of Conventional Systems of Sanitation

- Most of them contaminate water sources
- High risk of disease spread and contamination (disease transmission route, e.g. leaking sewers, sludge production, open defecation, e.t.c)
- Use a lot of Water and hence reduction in quantity for other uses (especially, flush systems)
- Most of these maximize potentially dangerous material
- They offer opportunity for vectors to breed (Most conditions in pits and sewer lines are favorable for pathogens to breed)
- Conventional methods prompt an “I don’t care attitude”. No body cares what happens at the end of a sewer line or beyond a pit latrine.
- The effect of mismanagement in conventional methods is high e.g. when sewer lines don’t work or if lines leak, they may affect more people when faeces are exposed, flies from the pile affect a larger area.
- More opportunity for accidents especially in pit latrines

## 1.2 Ecological Sanitation systems

Ecological Sanitation (Eco-san) is an alternative to conventional sanitation systems. It attempts to address the shortcomings of the traditional systems. It is based on an Eco-system approach and treats human urine and faeces as a valuable resource to be recycled, and preventing pollution rather than attempting to control it. It takes away smell, reduces quantity to handle and makes the human excreta harmless to be used as fertilizers.

### 1.2.1 Objectives of Eco-san

The primary goals of ecological sanitation can be summarized as;

- |             |   |                       |
|-------------|---|-----------------------|
| <i>i.</i>   | Disease prevention by Sanitizing human faeces         | <b>Zero Infection</b> |
| <i>ii.</i>  | Reduced water use thus, prevention of pollution       | <b>Zero Pollution</b> |
| <i>iii.</i> | Recovery of plant nutrients by Recycling human faeces | <b>Zero Waste</b>     |

---

Faeces are sanitized through dehydration or composting and if necessary, the material from the toilet is taken for secondary treatment, with high composting temperatures under controlled conditions. This applies especially when excreta is collected from a larger area or many households. A communal secondary treatment area could be developed with the guidance of health staff or specialized people.

Human urine is in most cases sterile and most of the fertilizer value is in it; it is also important to recover the nutrient in urine and use it in our gardens.

**Both drop and store, and flush and discharge, pollute water resources and the nutrient in human excreta is wasted while Ecological Sanitation conserves both.**

## 2 DESIGNING AN ECOSAN TOILET

Designing an Ecosan toilet is essentially choosing from the many available options those that suit the circumstances and preferences of the user. There are a number of Ecosan systems and this makes it possible to find one that is culturally acceptable and affordable. Some systems are sophisticated and expensive while others are simple and low cost. There is often a trade off between cost and operation; lower cost systems mean more manipulation and care of the system while with higher cost systems, manipulation and cost can be reduced.

### 2.1 Ecosan as a System

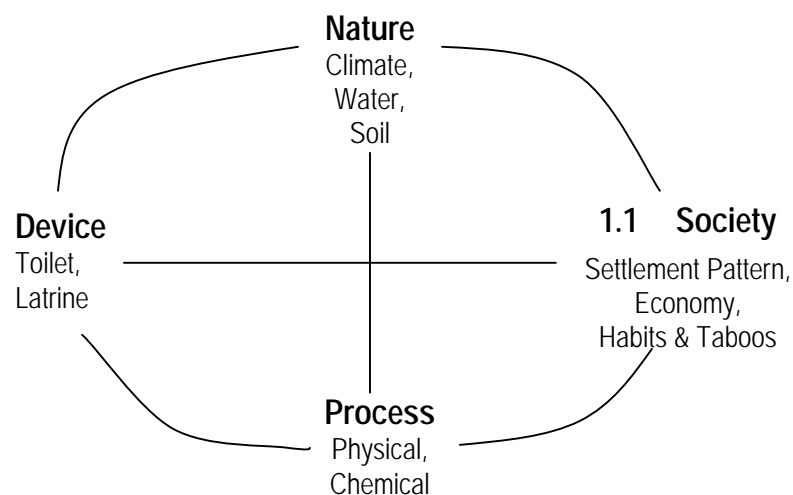

Fig 1. Sanitation as a system (adapted from *Ecological Sanitation*, Sida)

---

When designing an Eco-san, it's essential that sanitation is understood as a system and that all the components of the system should be considered together. The main components of an Eco-system are Nature, Society, Process and Device. (See fig above).

- ◆ Nature.  
The most relevant nature variables are climate (Humidity, Temperature), Water (amount available, ground water level) and soil (stability, permeability)
- ◆ Society.  
Includes settlement pattern (concentration/dispersed, low/high rise), attitudes (faecophobic/faecophilic), habits (washers/wipers), beliefs and taboos related to human excreta, economic status
- ◆ Process  
Includes physical, chemical and biological processes by which human excreta are sanitized/turned into an inoffensive useful pit
- ◆ Device  
Includes the on-site structures specifically built for defecation and urination.

## 2.2 Ecosan Toilet Components

Ecological toilets have three basic components

- a) a pedestal or squatting pan
- b) a slab and a chamber/vault
- c) and sometimes a superstructure (if it is sited outdoors)

Fig 2. Dehydration Ecosan Toilet

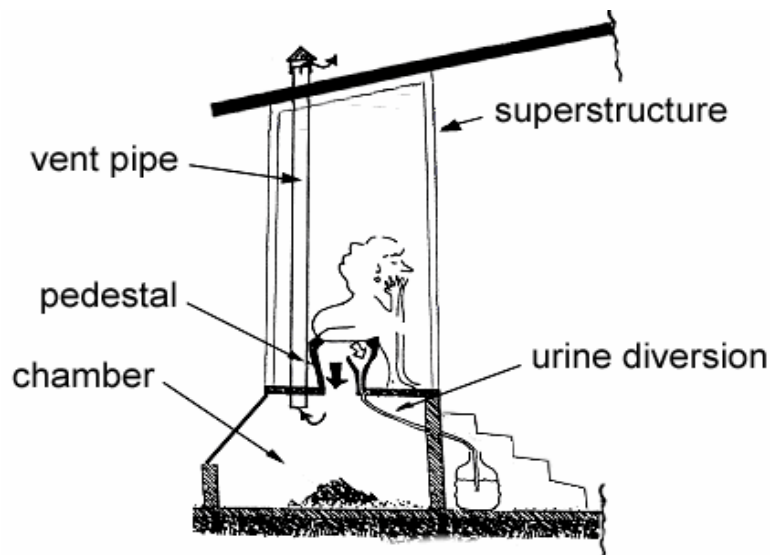

---

## 2.3 Types of Ecological Sanitation Toilet Systems

We have two types namely dehydrating and composting systems. These are named from the method used to sanitize the faeces.

### a) Dehydrating Toilets

These toilets sanitize the faeces by reducing the moisture content of the faeces thereby denying the pathogens the basic requirements for their living. The moisture content in the toilet should be reduced to 25% or less. Dehydration is achieved by;

- Heating
- Urine diversion
- Addition of absorbents such as ash, dry soil, saw dust, e.t.c.
- Ventilation

#### **Heating:**

Normally solar heating is utilized because of the cost consideration. The cover for the opening used for emptying chambers doubles as a solar collector. The metal sheet covers are painted black for maximum absorption of heat. Heating increases evaporation, destroys pathogens and controls flies. The solar heater must be fitted to prevent water as well as flies from entering the vault. It should be placed facing the sun.

#### **Urine diversion:**

Urine is basically sterile. Urine is diverted to keep the solid excreta dry, to conserve the urine's fertilizer value, and to reduce the volume of the potentially dangerous material (not making the problem bigger).

Urine and faeces go different ways and are kept and sanitized separately. This achieved with the use of urine diverting squatting pans or seats.

#### **Mixing then draining:**

The urine and faeces could go into the same hole then urine drained out. This requires provision in design for draining material at the bottom of the toilet. In this case urine must first be sanitized before recycling because it has been in contact with faeces.

#### **Mix then evaporate:**

This is largely applicable in extremely dry climatic conditions. Both urine and faeces can be treated together but this system is more prone to getting the contents wet and such a danger. It is not recommendable.



---

### **Addition of dehydrating materials (ash, lime, sawdust etc)**

Dehydrating materials absorb moisture from the faeces for quick pathogen destruction and provide a non-attractive atmosphere for fly breeding.

Addition of ash after every visit is more advantageous. In addition to assisting in drying the faeces it increases the pH of the contents; an environment that destroys the pathogens.

### **Ventilation:**

Ventilation controls the odour and accelerates vapor removal.

These toilets have been found to be the most successful of the Ecosan toilets in Uganda.

## **b) Composting toilets**

The excreta is transformed into humus through a biological process before it is disposed. In this system, both faeces and urine go down the same hole. Micro-organisms play a major role in this process.

### **Conditions for good composting:**

- Carbon Nitrogen ratio 15/1 or 30/1
- Oxygen (Aeration)
- Moisture Content 50% - 60%
- PH >7
- Temperature <50°C
- Requires addition of bulking matter to help in aeration during composting.
- Carbon material can be increased by supply of grass, garden litter, sawdust, and organic household residue; for the optimum C: N for increased rate of decomposition.
- Lay at least a layer of dry grass, husks and dry soil on the floor of the chamber to absorb moisture, prevent faeces from sticking on the floor, and provision of necessary micro-organisms responsible for decomposition.
- Earthworms will optimize rapid degradation of chamber contents. Volume of final materials is considerably reduced.
- Usually its better to divert the urine or else more bulking materials are needed.

**Ecosan toilets can be single vault or double vault, Urine diverting or non-urine diverting, solar heated or not solar heated. Each type with its own advantages and disadvantages.**

---

## 2.4 Products of Ecosan (Dehydration Toilet)

### 2.4.1 Urine

The diverted and collected urine can either be:

- Infiltrated into a soak pit
- Infiltrated into an evapotranspiration bed
- Used the same day for irrigation
- Stored on site for later collection and application

### 2.4.2 Faecal Matter

The crumbly cake that remains when faeces dry is not compost but rather a kind of mulch which is rich in nutrients, carbon and fibrous material. This cake is mixed with a little soil before application to the fields.

The products of primary processing (excreta) can be converted into a product known as humus by Secondary Processing. It looks, smells and has the consistency of loam like soil.

Various sites can be used for secondary processing. These include pits or trenches in the earth, plastic or concrete buckets/jars and plastic bags.

The chamber contents are tipped into the bucket/pit/bag, leveled and covered with a good layer of fertile soil, leaf moulds or humus. The organisms in the humus digest and convert the excreta into humus. This is done in stages and after the last filling, the excreta is leveled off again and tipped with fertile soil. The container/pit is then watered and covered. The various ingredients will decompose within two or three months to form humus, which can then be removed and applied in the garden. The container can then be reused.

The temperatures in the buckets can be increased by painting the buckets black. This increases the humidity in the bucket thus aiding the composting process.

The containers/pits can also be used to grow vegetables, flowers or young trees. Water drainage holes are drilled in the bases of the containers. A layer of humus is first placed in

---

the container followed by excreta from the toilet and by a layer of soil. The seedlings can then be planted.

## **2.5 Other Design Options**

### **2.5.1 Processing Vaults/Chambers**

There are a number of options under processing chambers. They include:

#### **i. Single vault**

This Option has the advantage of reduced cost, less space requirement and only one fixed seat or pan. The disadvantage is the risk that fresh material can be mixed with fully processed material when the chamber is emptied. The faecal material therefore, is transferred to another pile/bin/container for further processing before being recycled.

#### **ii. Single vault with bucket/bin/basket**

Here the risk has been eliminated because faeces drop into a movable container. The disadvantage is that if the container is large it is difficult to move it, and if small it has to be emptied frequently. Another disadvantage is that dehydration may be slower in a tight container. From this point of view, it is better to use a loosely woven basket as a container.

With single vault systems, the system must ensure isolation of faeces until pathogens have been reduced to acceptable levels. The faecal material is usually transferred to another container for further processing before being recycled.

#### **iii. Double vault**

- With two seats or a double squatting pan
- With a movable seat or squatting pan
- With fixed seat/squatting pan and baffle plate

This Option is good from a safety point of view but requires either double or movable fixtures. Most toilets are designed with two vaults. In these systems, each vault is used alternately for a certain period. When a vault is filled, a switch to the second vault is made. The contents of the dormant vault are emptied with the assumption that after several

---

months without new faecal matter, the contents of the dormant vault should be safe to handle.

### **2.5.2 Anal cleaning Material**

Cultures differ in the use of cleaning materials after defecation. Some use paper, some use vegetation material or stones and others use water. The inappropriate disposal of cleaning material in a toilet can cause problems. In addition to anal cleaning materials, other things such as tampons, sanitary towels and condoms are frequently disposed of in toilets.

A composting toilet can handle all kinds of paper and solid objects. In a dehydrating toilet however, paper does not decompose. The following solutions can be adopted for the problem of paper in a dehydrating toilet:

- Compost the output from the processing chamber
- Burn the output from the chamber
- Place the toilet paper in a special container and burn it periodically

Water for anal cleaning should be handled away from the squat hole in dry toilets.

### **2.5.3 Absorbents and Bulking agents**

Absorbents like ash, lime, sawdust, husks, crushed dry leaves, peat moss and dry soil are used to reduce smells, absorb excess moisture and make the pile less compact as well as less unsightly for the next user. They are applied immediately after defecation in order to cover the fresh faeces. They are used in both dehydrating and composting toilets.

### **2.5.4 Ventilation and Aeration**

Ventilation removes odours, dries out the contents and in composting toilets, provides oxygen for the decomposition process. The need for a vent pipe is determined by climate, wetness of the input into the processing chamber and standard desired.

---

A vent pipe should have a diameter of 10 – 15cm. In humid climates with large amount of liquid to be evaporated, the diameter could be larger, up to 25cm. The pipe should be as straight as possible and reach 30 – 90cm above the roof.

## 2.6 Sizing Vaults

### Basic Design Data:

1. Volume of solid excreta per person per year = 50l
2. Volume of urine per person per year = 500l
3. Volume of the dry materials (ash) added per person per year = 50l
4. Retention time = 6 months

(We assume that the ash added is equivalent to the faeces and that 1 Kg is equivalent to 1 litre)

### Sizing the Vaults

$$V = \frac{N(F+A+U)}{1000} \text{ where}$$

$V$  = Volume of the vault in  $m^3$   
 $N$  = Number of users  
 $F$  = Volume of faeces (in litres) produced per person within the retention time  
 $A$  = Volume of ash (in litres) added per person per year  
 $U$  = Volume of urine (in litres) added per person per year

### Example 1 Normal household (6 users) unit, urine diverting unit and retention time of 6 months using a double vault system

$$V = \frac{6(50 + 50 + 0)}{1000} = 0.6m^3$$

A vault say 0.8 x 0.8 x 1m would be enough

---

### 3 CONSTRUCTION OF THE ECO-SAN TOILET

#### 3.1 Choice of materials

The toilet is constructed from naturally existing or manufactured materials depending on the economic status of the owner, thus, the technology caters for both the poor and the rich.

- For low income earners one can construct an ecosan toilet entirely from locally available natural materials like stones; mud, clay, water, tree poles & logs, reeds, ropes and grass for thatching (Mud and Wattle Structure)
- For middle –income earners, one can construct the structure using bricks, sand, timber, corrugated iron sheets and paint
- For the rich, the structure could be roofed with tiles and polished with tiles, terrazzo, e.t.c.

The materials therefore, that can be used are:

#### **Local Materials:**

Stones; hardcore

- Sand
- “Mud” Clay soil mixed right quantity of water
- Tree poles & logs
- Reeds and ropes
- Grass for thatching

All these materials mentioned above can produce a very strong and beautiful Ecological Sanitation toilet provided there is good workmanship. They (materials) are available in our yards and plantations.

#### **Other Materials:**

Cement

- Steel bars
- PVC Vent pipe
- PVC pipes for urine diversion
- Door (Timber or steel)
- Iron sheets
- Nails
- Sawn timber

- 
- Steel covers for the toilet vaults
  - Polyethylene paper (Damp Proof Membrane)

These are the basic manufactured materials needed for the construction of a moderate ecological sanitation toilet. They are readily available in most hardware shops. The toilet may further be polished with paint, Tiles or terrazzo; depending on the choice and the capability of the owner.

### **3.2 Site Considerations**

1. Site the structure as close to the house as possible preferably in-house
2. Use any slope to your advantage so that you avoid the steps

### **3.3 Other Considerations**

1. Double Vault or Single Vault
2. Urine Diversion or mix and drain or mix and evaporate
3. Solar heating or not

### **3.4 Construction details for special consideration**

- Minimize contact with fresh un-sanitized faeces
- Proper plumbing to avoid urine leaking into the chambers
- Avoid steps if you can so that the disabled and the elderly can easily use the facility.
  - Structures should be watertight. Remember to always include the damp proof membrane
  - Urine discharge pipe shouldn't be small as to cause blockage due to uric acid build up to ¾" or 1" pipes work well
  - Vent pipe is required for aeration and should be cleaned (especially of cobwebs) occasionally
  - Solar heating is added to hasten pathogenic die off and quick drying of faecal matter

### **3.5 Construction**

#### **3.5.1 Brick Masonry Dehydration Unit**

Most care in the construction of an Ecosan toilet is taken when constructing the Substructure. Two watertight vaults of the same size are constructed above the ground

---

to allow easy emptying and to prevent water from getting into the vault. This also prevents the contamination of groundwater. The vaults are constructed on a concrete (1:3:6) floor. The floor should have a Damp Proof membrane. The vaults sizes have already been determined by this time. The brick walls, 150mm(6 inches) thick bonded with cement-sand mortar 1:5 mix, are erected.

The reinforced concrete (1:2:4) slab is cast. The urine diversion pans should be fitted at least 75mm above the slab to avoid water entering the vault when cleaning. The superstructure walls (also 150mm thick) are brickwork and plastered with cement-sand mortar 15 – 25mm (1 inch) thick, 1:5 – 1:3 mix depending on the quality of sand.

The roof consists of Corrugated Iron Sheets supported by Timber purlins 100 x 50mm (4 x 2 inches), on Timber Rafters 100 x 50mm (4 x 2 inches), on 100 x 75mm (4 x 3 inches) Wall plate and fascia board 225 x 25mm (6 x 1 inches). A vent 100mm (4 inches) diameter PVC pipe is installed such that it is at least 600mm above the roof. Generally, the vent pipe should be slightly higher than the roof ridge or the highest point of the roof, such that the flow of air is not impaired. The vent pipe should have a mesh at the top to trap flies and a rain stopper to prevent rain from entering the vaults through the pipe.

The solar heaters consist of a metallic sheet painted black and are placed in such a way as to trap as much sunshine as possible.

Depending on the capability of the owner of the unit, the unit may be finished with tiles or just plastered.

### **3.5.2 Mud & Wattle Dehydration Unit**

Our naturally existing materials can be used to construct a beautiful and strong Ecological Sanitation toilet. The principles of construction for this type of toilet are the exactly the same, the difference is in the materials and of course the cost per unit item.

The foundation is comprised of hardcore that is placed and compacted. Where possible, sand blinding may be done otherwise, a selected soil may be used to provide



---

a layer of blinding on top of hardcore. A damp proof membrane is also necessary to keep the chambers watertight.

Stones or brick walls for the vaults are erected using mud/clay soil mixed with water as the jointing material. The foundation of the structure should be raised to about 300mm above the ground to avoid floods and surface run off water. The walls of the vaults should be  $\geq 300\text{mm}$  because there is no cement used and therefore, the wall thickness is increased to reduce the slenderness ratio. Logs are used for the squat slab. These are joined together with nails or locally made ropes.

Alternatively, the vaults may be erected using a frame of logs and reeds filled using mud/clay soil mixed with a little water and thoroughly churned. Logs are used as the squatting slab. The logs and reeds are held in place using locally made ropes.

The shelter, made of vertical poles supporting the roof, is erected in the ground. Horizontal members are tied in pairs on these vertical poles on both sides (inside and outside) to hold the mud for the walls. The vertical poles provide the skeleton for the superstructure, and support the roof.

Finishing is done using clay soil mixed with cow dung and ash. A Door made of reeds or mat may be used. Roofing is made of rafters and purlins from the tree plantations and forests. Grass or banana fibers can be used as roofing materials.

#### 4 OPERATION AND MAINTENANCE OF ECOSAN FACILITIES

- Training of the user on the proper use of the facility is a first step in ensuring its proper use
- Any smell of fly menace is a complaint from the facility that something is wrong
- Hang the operation and maintenance chart in the toilet so that visitors can as well learn how to use the facility (*O&M chart attached*)
- Remember any problem that develops can easily be rectified and the facility stays in use

A well functioning toilet has cone build up (not flat and wet) and no smell or flies

---

## 5 MOST COMMON PROBLEMS

1. Wrong designs.; care must be taken to design appropriately for the demand at hand. Sizing of the chambers is very important to be able to achieve the right retention period.
2. Shoddy workmanship; Demonstration toilets should be better than average (design, materials, workmanship, e.t.c.)
3. Squatting hole, Should be at least 6"
4. Blockage of the urine diversion; use warm water if it is due to uric acid build up or otherwise use a straight rod to unblock. A provision for unblocking be included in the plumbing works
5. Poor maintenance (O&M), if eco-san toilets are not well maintained, the content might turn wet which creates odour and flies (complaining toilet). They need enough drying material and a lot of attention to details. If the toilets have no odour, flies, maggots, it is a sign of good use. If there is odour, check vents and clean them.
6. Anal cleaning; it is possible to provide for any anal cleaning though questions have arisen about cultures that use water for anal cleaning. Designs are available that divert water from the squat hole. Others wash from the urine diversion and soak away the urine or retain the urine to kill off pathogens before they are taken to the gardens.
7. Vent pipe should be at least 1m above the roof and roofed to deny rainwater entering the chambers.

---

## APPENDIX

### Drawings

1. Double Vault House Hold Ecosan Toilet
2. Technical Drawing for House hold Ecosan Toilet
3. Technical Drawing for Household Ecosan Toilet for Washers
4. School Ecosan Toilets
5. Operation and Maintenance Chart

General Notes

- 1) All dimension are in mm
- 2) Concrete slab is reinforced with 10mm dia bars @ 150 c/c.
- 3) Do 800 x 2100 (timber match boarded)

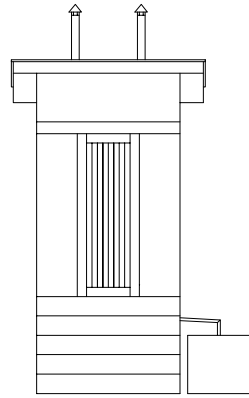

scale 1:100  
FRONT ELEVATION

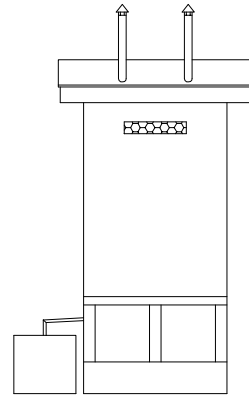

scale 1:100  
REAR ELEVATION

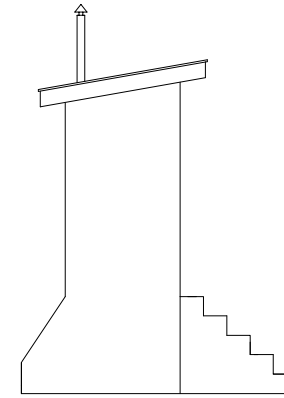

scale 1:100  
TYPICAL SIDE ELEVATION

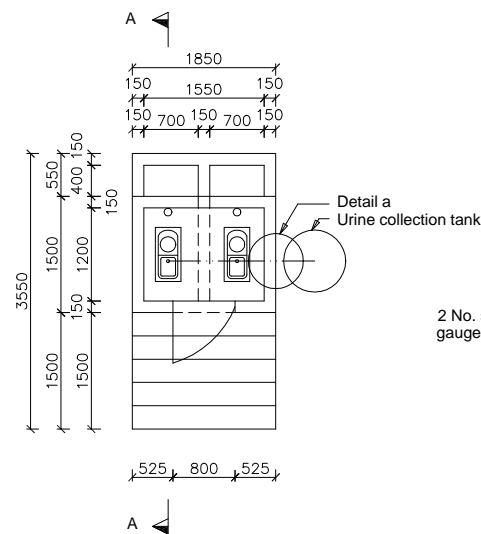

scale 1:100  
GROUND PLAN

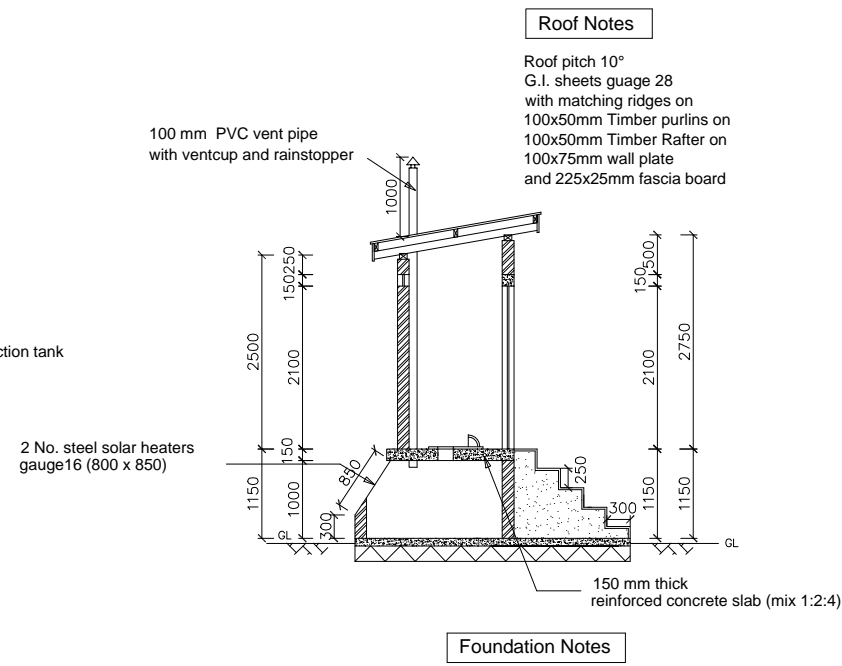

scale 1:100  
SECTION A-A

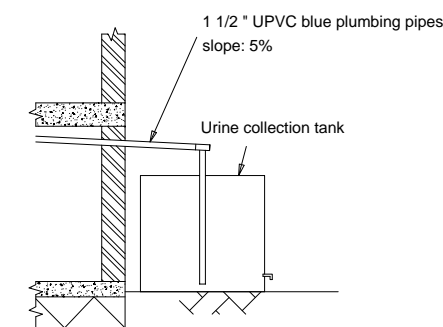

scale 1:50  
DETAIL a

Roof Notes

Roof pitch 10°  
G.I. sheets guage 28  
with matching ridges on  
100x50mm Timber purlins on  
100x50mm Timber Rafter on  
100x75mm wall plate  
and 225x25mm fascia board

Foundation Notes

50mm thick cement/sand screed on  
100mm site concrete mix(1:3:6) on DPM  
50mm blinding on  
200mm well compacted hardcore filling on firm ground

MINISTRY OF WATER, LANDS AND ENVIRONMENT  
DIRECTORATE OF WATER DEVELOPMENT

ECOLOGICAL SANITATION

ONE STANCE ECO - SAN TOILET

South Western Towns Water and Sanitation (SW TWS) Project P.O Box 75 Kabale Assisted by the Government of Austria	Designed :SWTWS Drawn :NLL Checked : Scale :1:100, 1:50 Date : APR 03   Drz N0: ECO/01
--	--

## Materials Estimates for the Construction of a Household Ecosan Toilet

S/N	Description	Unit	Qty
	<b>SITE CLEARANCE</b>		
1	Clearing site and Excavation of topsoil	Sm	13.0
	<b>FOUNDATION</b>		
2	Hardcore	Cm	2.3
3	Sand	Cm	0.5
4	Cement	Bags	2.0
5	Aggregates	Cm	0.4
6	Damp Proof Membrane	Sm	6.6
	<b>SUBSTRUCTURE (Including Plastering of walls)</b>		
7	Bricks (230 x 100 x 75mm)	No.	320
8	Sand	Cm	0.6
9	Cement	Bags	5.0
10	Aggregates	Cm	0.2
11	10mm Square Twisted High Yield reinforcement bars	Kgs	41.4
12	Binding Wire	Kgs	1.0
13	Timber (12 x 1") for Shuttering	Pcs	5.0
14	Eucalyptus poles for Shuttering	Pcs	2.0
	<b>SUPERSTRUCTURE</b>		
15	Bricks (230 x 100 x 75mm)	No.	630
16	Sand	Cm	0.3
17	Cement	Bags	2.0
18	Eucalyptus Poles (for scaffolding)	Pcs	8.0
19	Nails (6")	Kgs	1.0
	<b>STAIRS/RAMP</b>		
20	Bricks (230x100x75mm)	No.	100
21	Sand	Cm	0.2
22	Cement	Bags	1.0
23	Aggregates	Cm	0.2
24	Hardcore	Cm	0.6
25	Murrum	Cm	2.0
	<b>ROOFING</b>		
26	Wall Plate (100 x 50, well preserved)	Pcs	1.0
27	Hoop Iron	Kgs	1.0
28	Rafters (100x50mm)	Pcs	1.5
29	Purlins (75x50mm)	Pcs	2.0
30	Corrugated Iron Sheets	Pcs	2.0
31	Roofing Nails	Kgs	2.0
32	Nails	Kgs	1.0
	<b>PLASTERING/RENDERING</b>		
33	Cement	Bags	12.0
34	Sand	Cm	2.0
	<b>FITTINGS</b>		
35	Door (800x2100mm)	No.	1.0
36	Solar Heaters (800x800mm)	Pcs	2.0

## Materials Estimates for the Construction of a Household Ecosan Toilet

37	100mm Diameter PVC Vent Pipes (with rain stopper)	Pcs	1.0
	<b><i>PLUMBING</i></b>		
38	1 1/4" PVC Pipe	Pcs	1.0
39	1 1/4" PVC Tee	Pcs	3.0
40	1 1/4" PVC Elbows	Pcs	1.0
41	1 1/4" PVC Plugs	Pcs	2.0
42	PVC Cement	Tin	1.0
43	Squatting pans	No.	2.0
44	Urine Tank	No.	1.0
	<b><i>ADMINISTRATIVE COSTS</i></b>		
45	Transport	Lumpsum	1.0
46	Skilled Labour (5000/=)	Mandays	15
47	Unskilled Labour (3000/=)	Mandays	20
48	Supervision	Lumpsum	1.0

General Notes

- 1) All dimension are in mm
- 2) Concrete slab is reinforced with 10mm dia bars @ 150 c/c.
- 3) Do 800 x 2100 (timber match boarded)

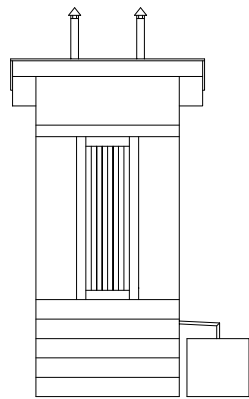

scale 1:100  
FRONT ELEVATION

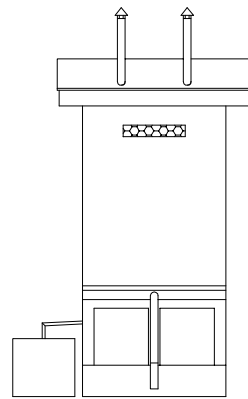

scale 1:100  
REAR ELEVATION

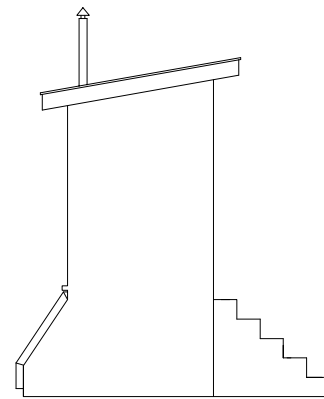

scale 1:100  
TYPICAL SIDE ELEVATION

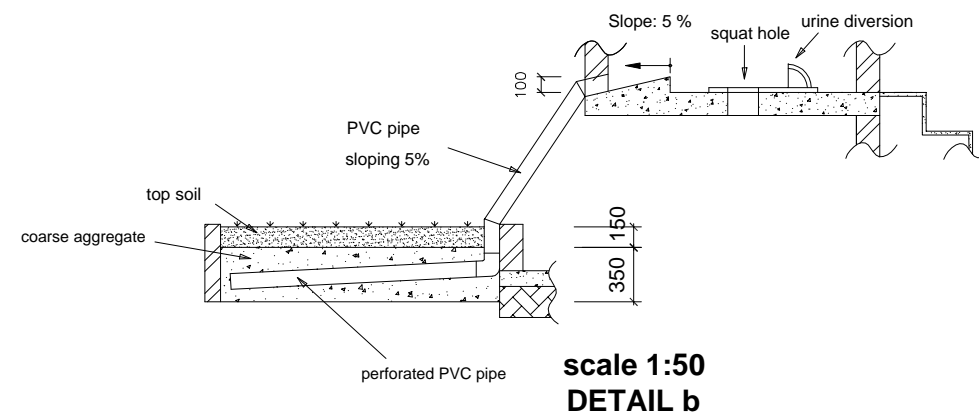

scale 1:50  
DETAIL b

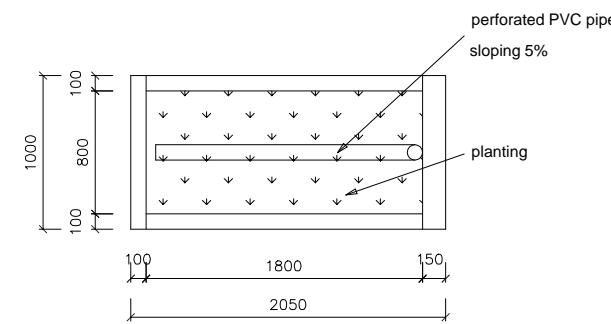

scale 1:50  
EVAPOTRANSPIRATION BED

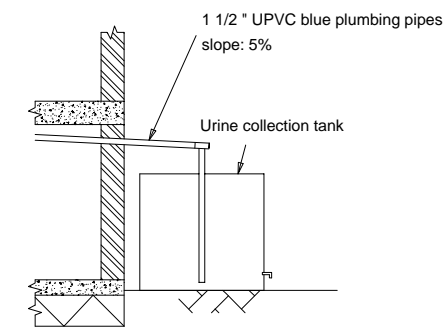

scale 1:50  
DETAIL a

Roof Notes

Roof pitch 10°  
G.I. sheets guage 28  
with matching ridges on  
100x50mm Timber purlins on  
100x50mm Timber Rafter on  
100x75mm wall plate  
and 225x25mm fascia board

100 mm PVC vent pipe  
with ventcup and rainstopper

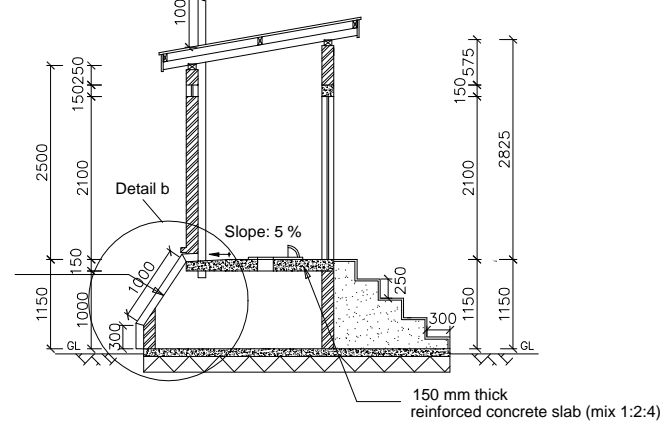

Foundation Notes

50mm thick cement/sand screed on  
100mm site concrete mix(1:3:6) on DPM  
50mm blinding on  
200mm well compacted hardcore filling on firm ground

2 No. steel solar heaters  
gauge 16 (800 x 1000)

Detail a  
Urine collection tank

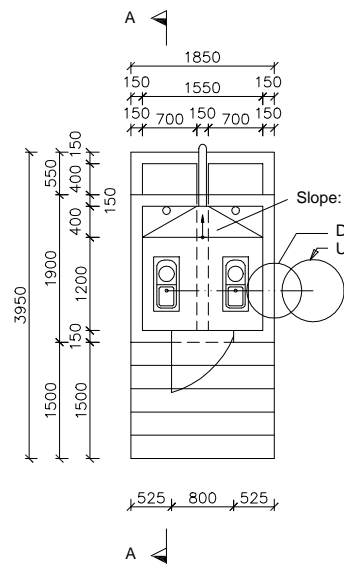

scale 1:100  
GROUND PLAN

scale 1:100  
SECTION A-A

MINISTRY OF WATER, LANDS AND ENVIRONMENT  
DIRECTORATE OF WATER DEVELOPMENT

ECOLOGICAL SANITATION

ONE STANCE ECO - SAN TOILET FOR WASHERS

South Western Towns Water and Sanitation (SW TWS) Project	Designed :SWTWS
P.O Box 75	Drawn :NLL
Kabale	Checked :
Assisted by the Government of Austria	Scale :1:100, 1:50
	Date : MAR 03
	Drz N0: ECO/02

## Materials Estimates for the Construction of a Household Ecosan Toilet for Washers

S/N	Description	Unit	Qty
	<b>SITE CLEARANCE</b>		
1	Clearing site and Excavation of topsoil	Sm	13.0
	<b>FOUNDATION</b>		
2	Hardcore	Cm	2.3
3	Sand	Cm	0.5
4	Cement	Bags	2.0
5	Aggregates	Cm	0.4
6	Damp Proof Membrane	Sm	6.6
	<b>SUBSTRUCTURE (Including Plastering of walls)</b>		
7	Bricks (230 x 100 x 75mm)	No.	320
8	Sand	Cm	0.9
9	Cement	Bags	7
10	Aggregates	Cm	0.3
11	10mm Square Twisted High Yield reinforcement bars	Kgs	41.4
12	Binding Wire	Kgs	1.0
13	Timber (12 x 1") for Shuttering	Pcs	5.0
14	Eucalyptus poles for Shuttering	Pcs	2.0
	<b>SUPERSTRUCTURE</b>		
15	Bricks (230 x 100 x 75mm)	No.	630
16	Sand	Cm	0.3
17	Cement	Bags	2.0
18	Eucalyptus Poles (for scaffolding)	Pcs	8.0
19	Nails (6")	Kgs	1.0
	<b>STAIRS/RAMP</b>		
20	Bricks (230x100x75mm)	No.	100
21	Sand	Cm	0.2
22	Cement	Bags	1.0
23	Aggregates	Cm	0.2
24	Hardcore	Cm	0.6
25	Murrum	Cm	2.0
	<b>ROOFING</b>		
26	Wall Plate (100 x 50, well preserved)	Pcs	1.0
27	Hoop Iron	Kgs	1.0
28	Rafters (100x50mm)	Pcs	1.5
29	Purlins (75x50mm)	Pcs	2.0
30	Corrugated Iron Sheets	Pcs	2.0
31	Roofing Nails	Kgs	2.0
32	Nails	Kgs	1.0
	<b>PLASTERING/RENDERING</b>		
33	Cement	Bags	12.0
34	Sand	Cm	2.0
	<b>FITTINGS</b>		
35	Door (800x2100mm)	No.	1.0
36	Solar Heaters (800x800mm)	Pcs	2.0



## Materials Estimates for the Construction of a Household Ecosan Toilet for Washers

37	100mm Diameter PVC Vent Pipes (with rain stopper)	Pcs	1.0
	<b><i>PLUMBING</i></b>		
38	1 1/4" PVC Pipe	Pcs	1.0
39	1 1/4" PVC Tee	Pcs	3.0
40	1 1/4" PVC Elbows	Pcs	1.0
41	1 1/4" PVC Plugs	Pcs	2.0
42	PVC Cement	Tin	1.0
43	Squatting pans	No.	2.0
44	Urine Tank	No.	1.0
	<b><i>EVAPOTRANSPIRATION BED</i></b>		
45	Excavate topsoil	Lumpsum	1.0
46	Coarse Aggregates	Lumpsum	1.0
47	Topsoil	Lumpsum	1.0
	<b><i>ADMINISTRATIVE COSTS</i></b>		
48	Transport	Lumpsum	1.0
49	Skilled Labour (5000/=)	Mandays	15
50	Unskilled Labour (3000/=)	Mandays	20
51	Supervision	Lumpsum	1.0

General Notes

- 1) All dimension are in mm
- 2) Concrete slab is reinforced with 10mm dia bars @ 150 c/c.
- 3) Do 1: 800 x 2100 (timber match boarded 4 No.)
- 4) Do 2: 900 x 2100 (timber match boarded 1 No.)
- 5) Handrail consists of 1" Gi pipe 850mm long cast into the wall and bolted into the door for the stance for PWDs
- 6) Balustrade on Ramp consists of 1 1/2" Gi pipe with horizontal members and vertical members 1200mm high at 800mm intervals.

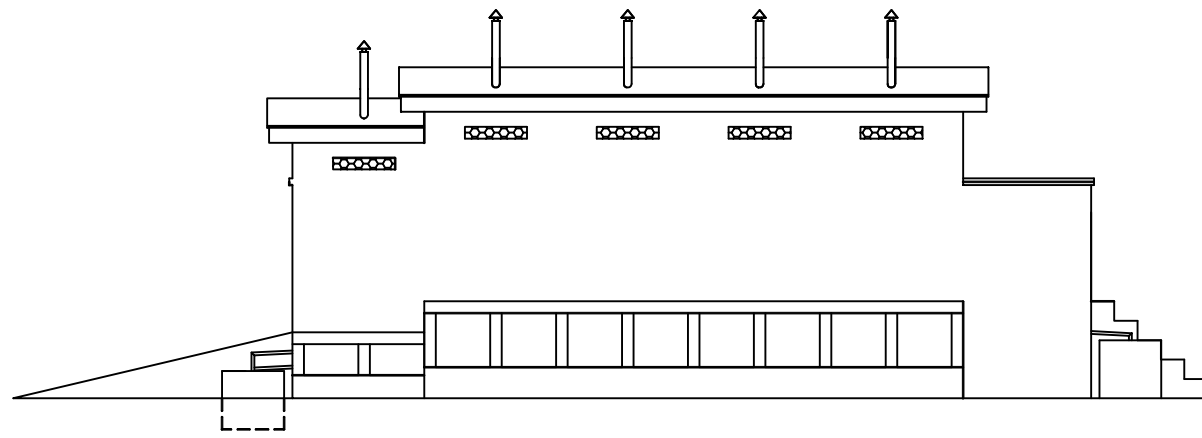

scale 1:100  
REAR ELEVATION

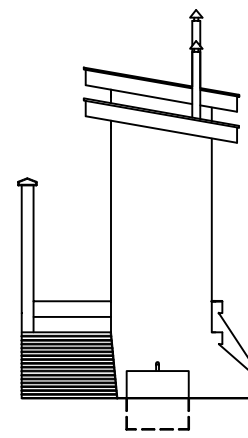

scale 1:100  
RIGHT SIDE ELEVATION

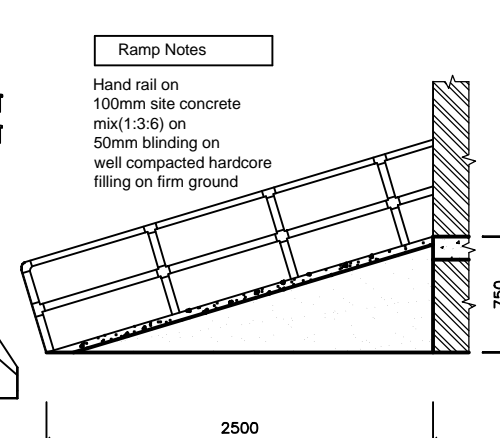

scale 1:50  
SECTION D-D

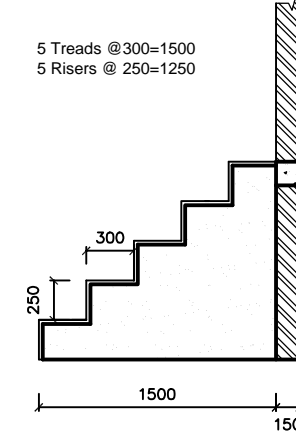

scale 1:50  
SECTION C-C

**Ramp Notes**  
Hand rail on 100mm site concrete mix(1:3:6) on 50mm blinding on well compacted hardcore filling on firm ground

5 Treads @ 300=1500  
5 Risers @ 250=1250

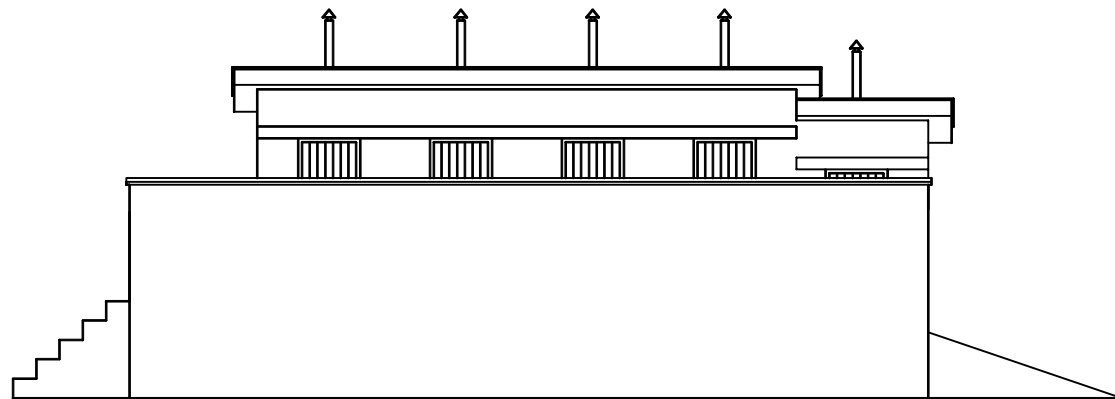

scale 1:100  
FRONT ELEVATION

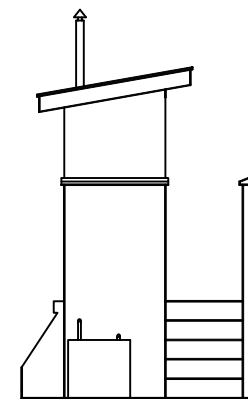

scale 1:100  
LEFT SIDE ELEVATION

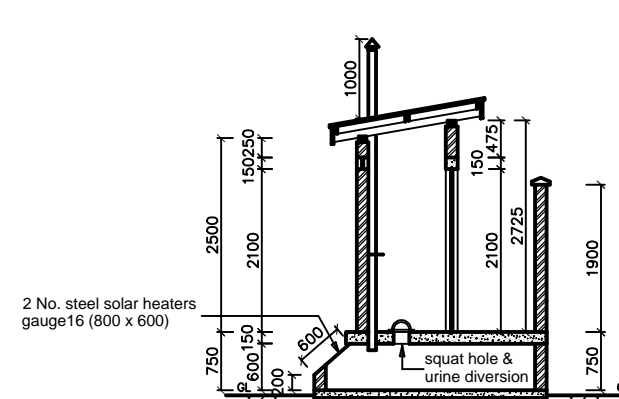

scale 1:100  
SECTION B-B

2 No. steel solar heaters gauge16 (800 x 600)

squat hole & urine diversion

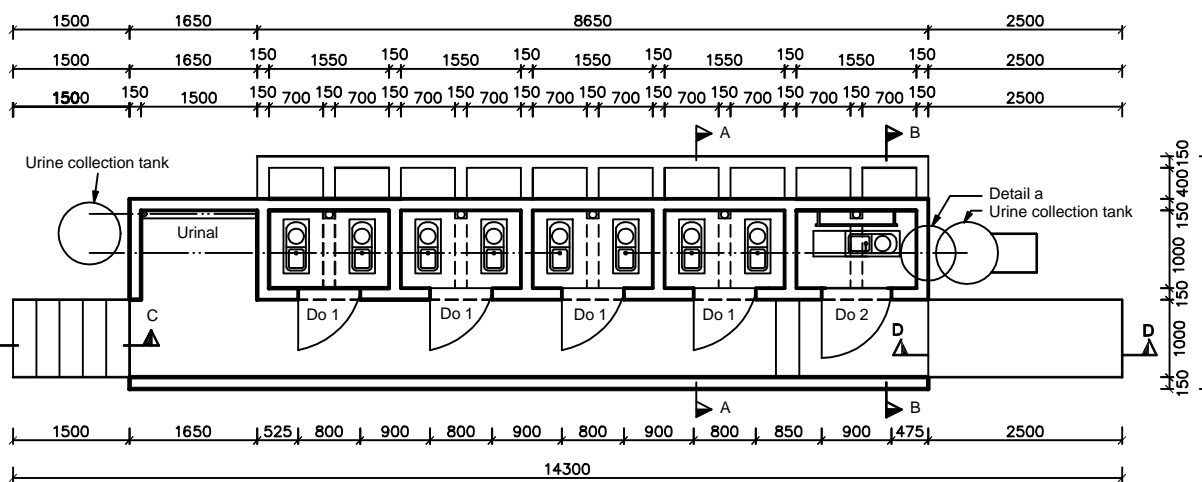

scale 1:100  
GROUND PLAN

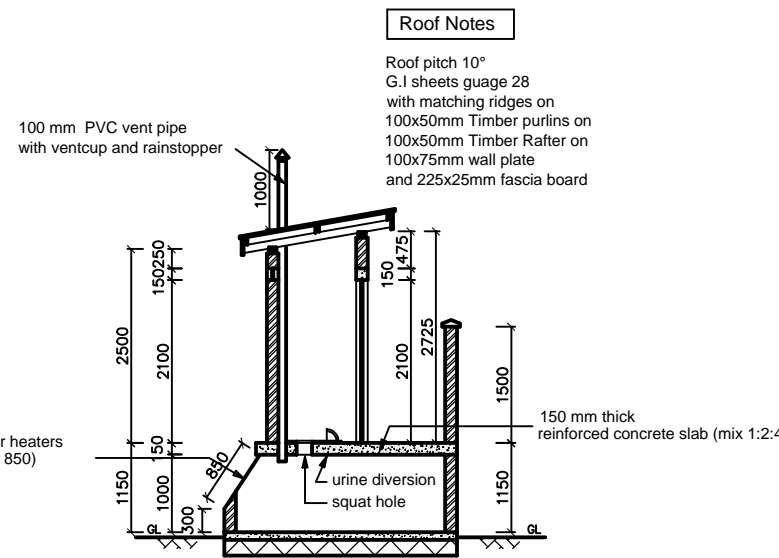

scale 1:100  
SECTION A-A

**Roof Notes**

Roof pitch 10°  
G.I sheets gauge 28 with matching ridges on 100x50mm Timber purlins on 100x50mm Timber Rafter on 100x75mm wall plate and 225x25mm fascia board

**Foundation Notes**

50mm thick cement/sand screed on 100mm site concrete mix(1:3:6) on DPM 50mm blinding on 200mm well compacted hardcore filling on firm ground

MINISTRY OF WATER, LANDS AND ENVIRONMENT  
DIRECTORATE OF WATER DEVELOPMENT

ECOLOGICAL SANITATION

SCHOOL ECO-SAN TOILET - BOYS WITH STANCE FOR PEOPLE WITH DISABILITIES

South Western Towns Water and Sanitation (SW TWS) Project	Designed :SWTWS
P.O Box 75	Drawn :NLL
Kabale	Checked :
Assisted by the Government of Austria	Scale :1:100, 1:50
	Date : MAR 03   Drg NO: ECO/06

## Materials Estimates for the Construction of a 5-Stance School Ecosan Toilet

S/N	Description	Unit	Qty
	<b>SITE CLEARANCE</b>		
1	Clearing site and Excavation of topsoil	Sm	66.0
	<b>FOUNDATION</b>		
2	Hardcore	Cm	10.0
3	Sand	Cm	1.0
4	Cement	Bags	10.0
5	Aggregates	Cm	2.0
6	Damp Proof Membrane	Sm	32.0
	<b>SUBSTRUCTURE (Including Plastering of walls)</b>		
7	Bricks (230 x 100 x 75mm)	No.	2,080
8	Sand	Cm	3.2
9	Cement	Bags	27.0
10	Aggregates	Cm	2.7
11	10mm Square Twisted High Yield reinforcement bars	Kgs	336.467L
12	Binding Wire	Kgs	2.0
13	Timber (12 x 1") for Shuttering	Pcs	10.0
14	Eucalyptus poles for Shuttering	Pcs	20.0
	<b>SUPERSTRUCTURE</b>		
15	Bricks (230 x 100 x 75mm)	No.	3,520
16	Sand	Cm	1.6
17	Cement	Bags	12.0
18	Aggregates	Cm	0.1
	8mm Square Twisted High Yield reinforcement bars	Kgs	52.0
	6mm Round Mild Yield Reinforcement bars (Stirrups at 150 c/c)	Kgs	6.0
	Timber (8 x 1") for Shuttering lintel	Pcs	6.0
19	Eucalyptus Poles (for scaffolding & Shuttering)	Pcs	30.0
20	Nails (6")	Kgs	4.0
	<b>STAIRS/RAMP</b>		
21	Bricks (230x100x75mm)	No.	250
22	Sand	Cm	0.5
23	Cement	Bags	2.0
24	Aggregates	Cm	0.5
25	Hardcore	Cm	1.2
26	Murrum	Cm	4.0
	Balustrade: 1 1/2" GI pipe	Pcs	2.0
	Cross Tees	No,	8.0
	<b>ROOFING</b>		
26	Wall Plate (100 x 50, well preserved)	Pcs	5.0
27	Hoop Iron	Kgs	3.0
28	Rafters (100x50mm)	Pcs	4.0
29	Purlins (75x50mm)	Pcs	9.0
30	Corrugated Iron Sheets	Pcs	9.0
31	Roofing Nails	Kgs	4.0
32	Nails	Kgs	4.0

## Materials Estimates for the Construction of a 5-Stance School Ecosan Toilet

	<b><i>PLASTERING/RENDERING</i></b>		
33	Cement	Bags	42.0
34	Sand	Cm	6.0
	<b><i>FITTINGS</i></b>		
35	Door (800x2100mm)	No.	4.0
36	Door (1000x2100mm)	No.	1.0
37	Solar Heaters (800x800mm)	Pcs	10.0
38	100mm Diameter PVC Vent Pipes (with rain stopper)	Pcs	5.0
	<b><i>PLUMBING</i></b>		
39	1 1/4" PVC Pipe	Pcs	3.0
40	1 1/4" PVC Tee	Pcs	10.0
41	1 1/4" PVC Elbows	Pcs	2.0
42	1 1/4" PVC Plugs	Pcs	2.0
43	PVC Cement	Tin	1.0
44	Urine diverting Squatting pans	No.	8.0
45	Urine Diverting Seat	No.	1.0
45	Urine Tank	No.	2.0
	<b><i>ADMINISTRATIVE COSTS</i></b>		
49	Transport	Lumpsum	1.0
50	Skilled Labour (5000/=)	Mandays	30
51	Unskilled Labour (3000/=)	Mandays	40
52	Supervision	Lumpsum	1.0

General Notes

- 1) All dimension are in mm
- 2) Concrete slab is reinforced with 10mm dia bars @ 150 c/c.
- 3) Do 1: 800 x 2100 (timber match boarded 4 No.)
- 4) Do 2: 900 x 2100 (timber match boarded 1 No.)
- 4) Handrail consists of 1" GI pipe 850mm long cast into the wall and bolted to the door in stance for PWDs
- 5) Balustrade on Ramp shall consist of 1½" GI pipes with horizontal members, and vertical members 1200mm high at 800mm intervals.

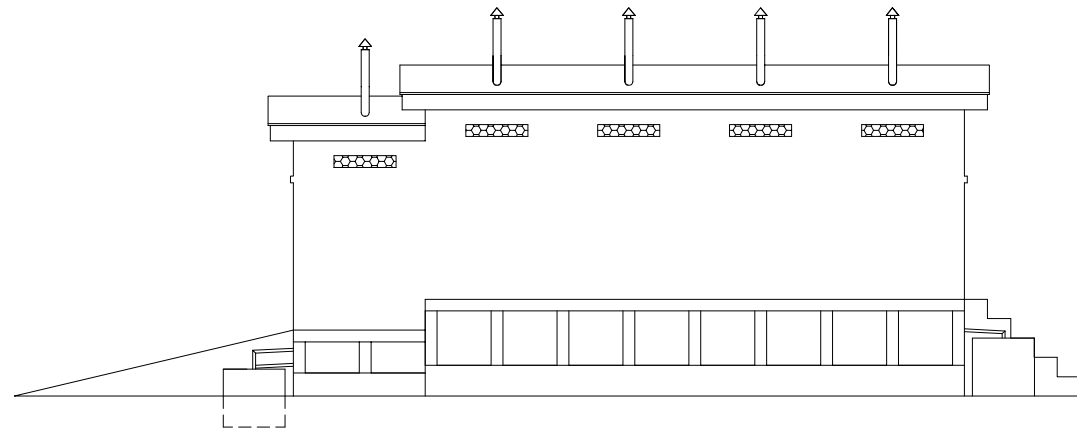

scale 1:100  
REAR ELEVATION

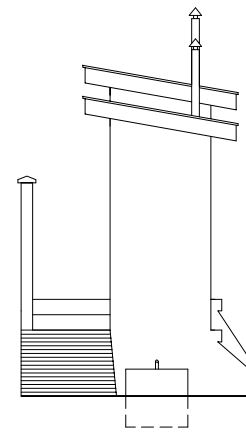

scale 1:100  
RIGHT SIDE ELEVATION

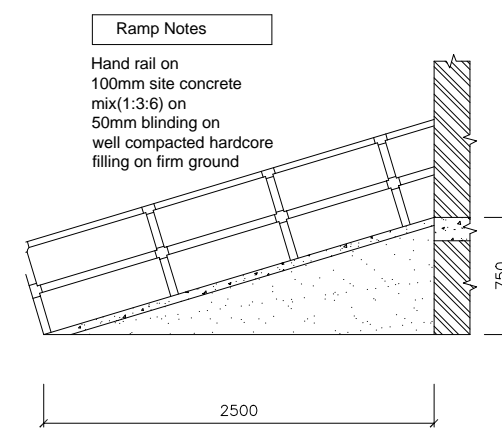

scale 1:50  
SECTION D-D

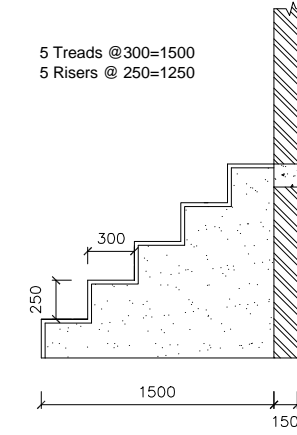

scale 1:50  
SECTION C-C

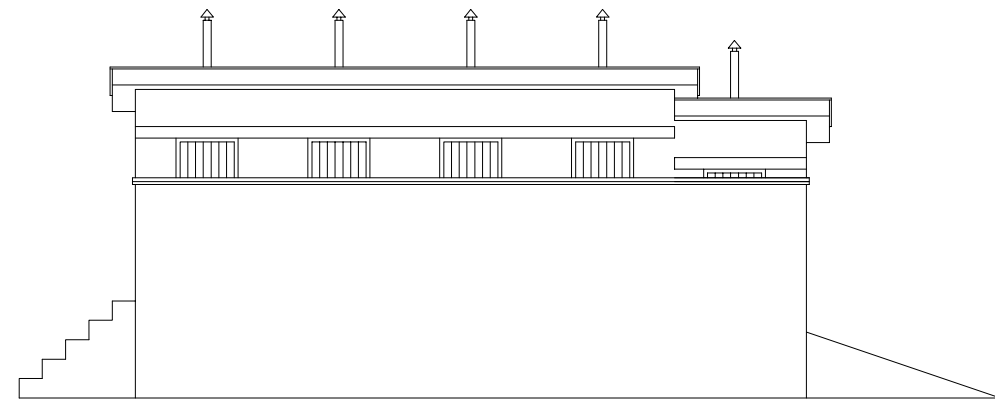

scale 1:100  
FRONT ELEVATION

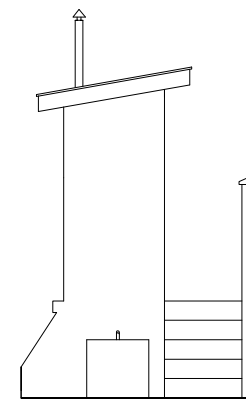

scale 1:100  
LEFT SIDE ELEVATION

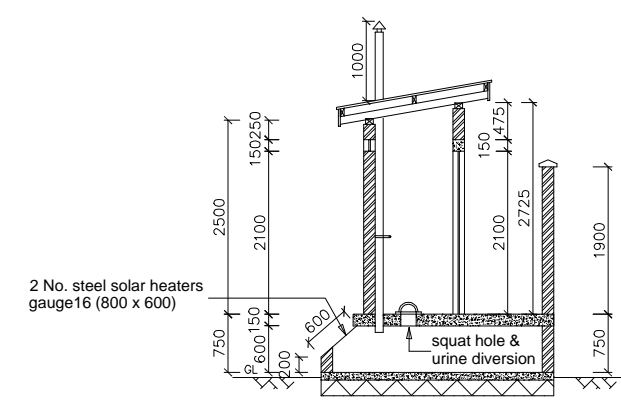

scale 1:100  
SECTION B-B

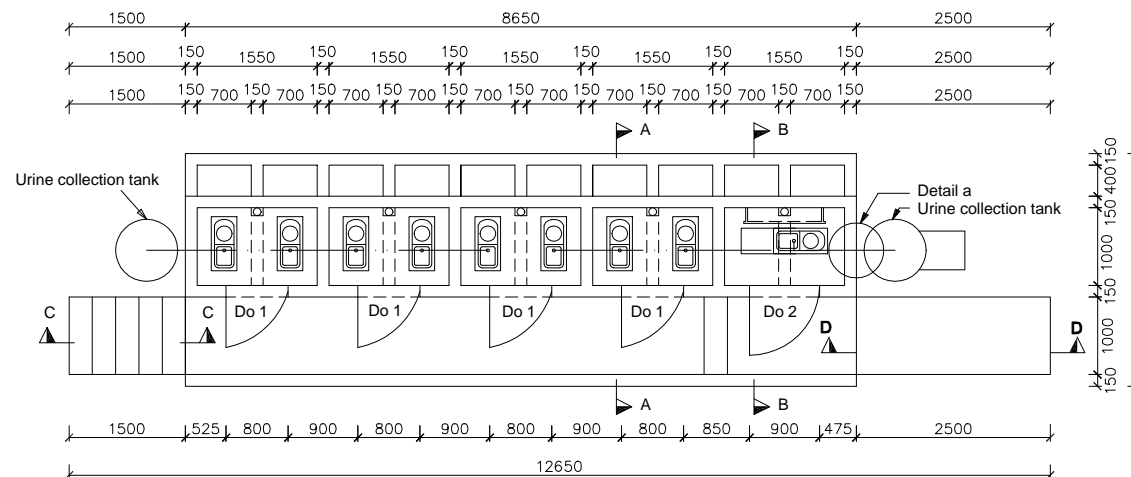

scale 1:100  
GROUND PLAN

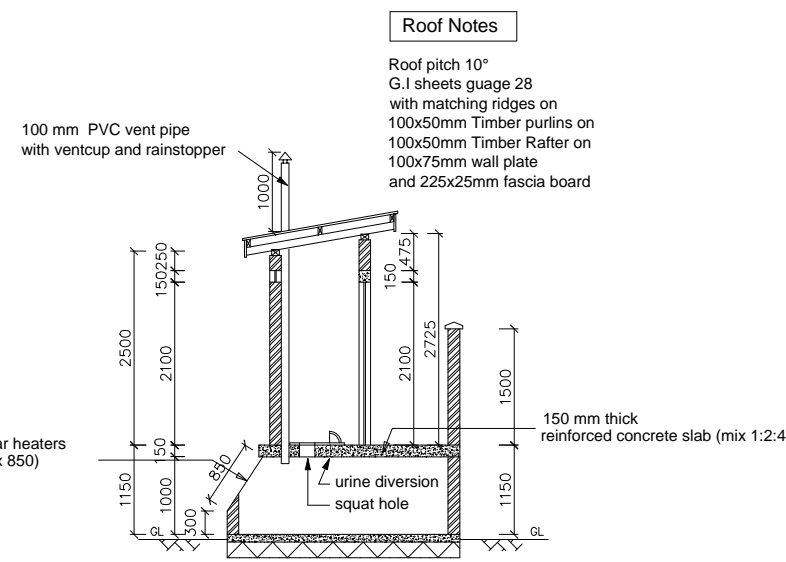

scale 1:100  
SECTION A-A

**Foundation Notes**  
50mm thick cement/sand screed on 100mm site concrete mix(1:3:6) on DPM 50mm blinding on 200mm well compacted hardcore filling on firm ground

**Roof Notes**

Roof pitch 10°  
G.I sheets gauge 28 with matching ridges on 100x50mm Timber purlins on 100x50mm Timber Rafter on 100x75mm wall plate and 225x25mm fascia board

100 mm PVC vent pipe with ventcup and rainstopper

8 No. steel solar heaters gauge16 (800 x 850)

150 mm thick reinforced concrete slab (mix 1:2:4)

urine diversion squat hole

MINISTRY OF WATER, LANDS AND ENVIRONMENT  
DIRECTORATE OF WATER DEVELOPMENT

ECOLOGICAL SANITATION

SCHOOL ECO-SAN TOILET - GIRLS WITH STANCE FOR PEOPLE WITH DISABILITIES

South Western Towns Water and Sanitation (SW TWS) Project	Designed :SWTWS
P.O Box 75	Drawn :NLL
Kabale	Checked :
Assisted by the Government of Austria	Scale :1:100, 1:50
	Date : MAR 03   Drz N0: ECO/05