

# **HUMAN-WASTE REUSE: GLOBAL OVERVIEW OF OPTIONS AND BACKGROUND MARKET ANALYSIS OF WASTE-BASED BUSINESS OPPORTUNITIES IN NAIROBI, KENYA**

Short-term consultancy for the Sanitation and Safe Water for All Program  
IFC, Kenya

Ashley Murray, Founder & CEO  
Waste Enterprisers Ltd.

July 2011

## **EXECUTIVE SUMMARY**

### *Purpose and Outputs*

The Sanitation and Safe Water for All (SSAWA) program is an initiative recently launched by the IFC in Nairobi, Kenya. The program was established to identify and develop market vehicles for improving access to water and sanitation. To that end, this report looks at a novel mode of sanitation entrepreneurship: the establishment of businesses that make productive and profitable use of wastewater and fecal sludge. That is, businesses that use human waste as a primary input into production for a variety of agricultural and energy products.

The report comprises three main components:

1. A brief situation and institutional analysis of sanitation in Kenya, with a focus on policies and programs that relate to reuse and private sector participation;
2. Detailed summaries and case studies of various wastewater and fecal sludge reuses, with emphasis on potential business models, investment requirements, and potential cost recovery; and
3. A preliminary assessment of the most promising waste-based business opportunities in and around Nairobi and roadmaps for more detailed business-feasibility studies.

The results and recommendations from this report will be used directly by the SSAWA to help guide and shape the program's goals and activities. However, the research is also broadly targeted at potential entrepreneurs, sanitation practitioners and decision makers, to build awareness and activity in the emerging waste-based business sector.

### *Situation and Institutional Analysis*

Coverage of improved sanitation in Kenya is estimated at about 52.5%, with stark regional and demographic differences. For example, most of the planned regions of Nairobi are served with a comprehensive sewer system while the residents of informal settlements in Nairobi rely primarily on shallow pit latrines, "flying toilets" and open defecation. Overall, about 19% of Kenya's population is connected to a sewer network. The most common on-site systems include ventilated improved pit latrines, traditional pit latrines, and waterborne systems that lead to septic tanks.

Improving sanitation is a high priority in Kenya, as the government recognizes its importance for economic growth and development. The Ministry of Public Health and Sanitation, established in 2008, is

responsible for coordinating the sector and with implementing the National Sanitation and Hygiene Policy that was launched in 2007. Wastewater/fecal sludge reuse, as well as increased private sector involvement, are both reoccurring themes in Kenya's sanitation policy and program documents. However, the link between reuse and the private sector, by way of promoting a waste-based business sector, has not been made.

### *Productive Use of Human Waste: Global Overview*

This report summarizes reuse options for eleven different combinations of human waste mediums and applications. These are: urine as fertilizer, raw fecal sludge as soil conditioner/fertilizer, raw fecal sludge for household and community biogas production, fecal sludge as a feedstock for biodiesel, dewatered fecal sludge as a growth medium for black soldier fly larvae, dewatered fecal sludge as a soil conditioner, dewatered fecal sludge as fuel, co-composted fecal sludge as a soil conditioner, wastewater for irrigation, and wastewater-fed aquaculture. On one end of the spectrum, wastewater reuse for irrigation is a widespread and age-old practice while at the other extreme, researchers are just beginning to develop technologies for converting human waste into biodiesel. Indeed, the technologies represented in this report have achieved various degrees of refinement and scale but each shows potential to be leveraged as a business opportunity, to the mutual benefit of entrepreneurs and importantly, struggling sanitation sectors.

In keeping with the aim of this report – to explore the financial viability of human-waste-based businesses and to reveal untapped opportunities for growing the waste-based business sector – each reuse is approached from a business perspective. To the extent possible, financial summaries of capital and operating costs and potential returns from different reuse options are detailed. The technologies are also described in the context of their present-day scope and scale of application.

### *Prospects for Reuse in Nairobi, Kenya*

There is an astounding degree of productive and creative reuse happening in Nairobi. However, this reuse is largely constrained to solid waste and animal waste, as there is a persistent psychological barrier against using human excrement for anything from agricultural to energy endpoints. Attitudes are slowly changing though, and with increased public awareness of the safety and environmental benefits of various reuses, this mental barrier can likely be overcome. Thus, any actor in the human-waste-based business sector should be aware of the cultural stigma against reuse, and should have well-conceived strategies for addressing it, but it should not prevent the development of a flourishing waste-based business sector in Kenya.

Based on preliminary analyses of existing sanitation solutions in Nairobi, market demand for various products of reuse, and interviews with key informants, this report focuses on two “best-bet” business opportunities in Nairobi: wastewater-fed aquaculture and urine collection and processing as fertilizer. Each are presented in the format of a business feasibility study, encompassing market viability, technical viability, business-model viability, and economic and financial-model viability. Within these categories, the report highlights known information and information that still needs to be collected and understood prior to launching a new business venture.

The Ruai Waste Stabilization Pond system is Africa’s second largest waste stabilization pond, and receives all wastewater from Nairobi’s sewerage areas. The system comprises eight series of ponds and has up to 24 ponds that could be stocked with fish for commercial aquaculture. Initial analyses of the financial, institutional and technical viability of this venture are quite promising. For example, conservative financial projections suggest that stocking just one pond in each of the eight series could yield a profit of nearly \$4 M per year.

Nairobi is in the unique position of having a number of having a number of urine-diverting toilets that make urine recovery possible. The company, Ecotact, has successfully installed 60 pay-to-use public toilets – Ikotoilets – in Nairobi, and they expect to reach 200 facilities by 2015. While the urine currently enters the sewer system with the rest of the flush water, the toilets are actually designed to divert the urine into dedicated holding tanks. The accessibility of urine in conjunction with the characteristics of the market for conventional fertilizer in and around Nairobi makes the city an attractive place to launch a urine-based fertilizer business. This is not, however, a ready-to-launch business. A significant pre-feasibility study on market demand and preferences is still required followed development of a processing technology for converting the urine into a marketable product.

### *Recommendations and Conclusion*

Waste-based businesses that rely on human waste as a primary input into the production of e.g. food and energy are a promising means of improving the function and reliability of urban sanitation value/service chains. Whether these businesses are fully government run, are a hybrid public-private partnership (i.e. management contract, BOT, concession) or are fully privatized, ultimately a portion of profits generated by the business should be used to help finance weak links in the value chain. Various horizon technologies such as biodiesel are enticing on a number of levels including potential profitability, volume reduction and safety of effluent (by-product), low operation costs of facilities, and dual benefits for

sanitation and climate change mitigation agendas. The future of sanitation is no more the design and construction of costly treatment and disposal facilities, but instead, the design and construction of (money-making) production plants.

## TABLE OF CONTENTS

Executive Summary .....	2
Table of Contents .....	6
List of Abbreviations .....	8
List of Figures.....	9
List of Tables .....	9
List of Boxes.....	11
<b>Chapter 1. Introduction .....</b>	<b>12</b>
1. Scope of work.....	12
2. Geographic Focus of Study.....	13
3. Methods .....	14
4. Outputs.....	15
<b>Chapter 2. Sanitation Situation Analysis.....</b>	<b>16</b>
1. Introduction .....	16
2. Sanitation Coverage in Kenya.....	16
3. Institutional Arrangements and Coordination.....	17
4. Presence of Reuse and the Private Sector within Sanitation Policy & Programming .....	20
<b>Chapter 3. Productive Use of Human Waste: A Global Overview .....</b>	<b>23</b>
1. Introduction .....	23
2. Urine use: Summary and Case Study.....	29
3. Fecal Sludge Uses: Summaries and Case Studies.....	33
3.1 Land application of raw/dewatered/treated FS as a fertilizer and soil conditioner .....	33
3.2 FS as a medium for black soldier fly larvae production (alternative fish/poultry meal).....	35
3.3 FS digestion for biogas production .....	39
3.4 FS as an industrial fuel .....	45
3.5 FS to charcoal (household cooking, industry).....	48
3.6 FS as a feedstock for biodiesel .....	49
4. Wastewater Use: Summaries and Case Studies .....	52
4.1 Wastewater-fed aquaculture .....	52
4.2 Wastewater-fed irrigation.....	57
5. Conclusion .....	59

<b>4. Prospects for Reuse in Nairobi, Kenya .....</b>	<b>60</b>
<b>1. Wastewater-fed Aquaculture .....</b>	<b>61</b>
1.1 Market viability .....	61
1.2 Technical viability .....	64
1.3 Business model viability .....	67
1.4 Economic and financial model viability.....	70
1.5 Key partners .....	71
<b>2. Urine as Fertilizer.....</b>	<b>72</b>
2.1 Market viability .....	72
1.2 Technical viability .....	74
1.3 Business model viability .....	76
1.4 Economic and financial model viability.....	79
1.5 Key Partners .....	80
<b>3. Slum Sanitation .....</b>	<b>80</b>
3.1 Umande Trust .....	81
3.2 Peepoople .....	82
3.2 Ecotact.....	83
<b>Appendix 1: Assumptions, data and sources for estimating economics of various excreta-reuse options .....</b>	<b>84</b>
<b>Appendix 2: List of Interviews.....</b>	<b>87</b>
<b>Glossary .....</b>	<b>88</b>
<b>Literature Cited .....</b>	<b>90</b>

## LIST OF ABBREVIATIONS

BSF	Black soldier fly
CBO	Community-based organization
CNG	Compressed natural gas
DO	Dissolved oxygen
DT	Dry ton
ESWG	Environmental Sanitation and Hygiene Working Group
FaME	Faecal Management Enterprises (project name)
FAMEs	Fatty acids alkyl (methyl) esters
FS	Fecal sludge
HTC	Hydrothermal carbonization
IFC	International Finance Corporation
IPCC	International Panel of Climate Change
KES	Kenya Shilling
KWI	Kenya Water Institute
LHV	Lower Heating Value
MDG	Millennium Development Goals
MJ	Megajoules
MoPHS	Ministry of Public Health and Sanitation
NEMA	National Environmental Management Authority
NPK	Nitrogen-phosphorus-potassium (fertilizer)
PPP	Public-private partnership
PSA	Pressure swing adsorption
SSAWA	Sanitation and Safe Water for All program
STUN	Struvite recovery from Urine in Nepal
USD	United States Dollar
WE	Waste Enterprisers Ltd.
WHO	World Health Organization
WSB	Water and Sanitation Boards
WSP	Waste stabilization pond
WSTF	Water Services Trust Fund
WSRB	Water Services Regulatory Board
WT	Wet ton



## LIST OF FIGURES

Figure 1. Map of Africa with Kenya highlighted (Left) and map of Kenya.....	14
Figure 2. Land area required for agricultural reuse of different waste streams generated by 100,000 peron-equivalents/yr. ....	25
Figure 3. Schematic of struvite production.....	31
Figure 4. Schematic of black soldier fly larvae-based swine manure treatment system. ....	38
Figure 5. Example of a biogas storage balloon. ....	41
Figure 6. Schematic of a water scrubbing system for biogas purification.....	42
Figure 7. Example set up of a PSA system.....	42
Figure 8. Acid-catalyzed transesterification of lipids to FAME.....	51
Figure 9. Acid-catalyzed esterification of fatty acids to FAME.....	51
Figure 10. Nairobi, Kenya with respect to the Ruai sewage treatment plant.....	63
Figure 11. Ruai waste stabilization pond system comprising eight parallel series of ponds.....	64
Figure 12. Fertilizer consumption – including nitrogenous, potash, phosphate – in Kenya between 1967 and 2009.....	72

## LIST OF TABLES

Table 1. Summary of actors at the national, regional and local levels in Kenya’s sanitation sector.....	18
Table 2. Vision, goals and activities laid out in key documents shaping Kenya’s sanitation sector. ....	19
Table 3. Resources available in various mediums of human waste, associated productive uses, and potentially marketable products. ....	24
Table 4. Comparison of receiving capacity of end users for various energy endpoints for fecal sludge (FS). ....	26
Table 5. Economics associated with different productive-reuse options for waste streams generated by 100,000 pe/yr. ....	27
Table 6. Average nutrient concentrations in urine.....	29
Table 7. Capital costs associated with struvite .....	31
Table 8. Economics of struvite production under prevailing market conditions in Siddhipur, Nepal.....	32
Table 9. Typical nutrient content of sewage and fecal sludges from different geographic regions. ....	35
Table 10. Protein and fat composition of black soldier fly prepupae .....	37
Table 11. Feed efficiency and weight gain among channel catfish fingerlings fed on Menhaden fishmeal and fishmeal substituted with BSF larvae.....	38

Table 12. Comparative analysis of the energy gain or deficit for a cement kiln burning 1 (wet) ton sewage sludge at 25% and 90% dry solids. ....	46
Table 13. Water quality standards for wastewater-fed aquaculture.....	54
Table 14. Capital and on-going costs associated with the Ahinsan Estate wastewater-fed aquaculture system .....	55
Table 15. Potential revenue generated per six-month catfish cultivation at the Ahinsan Waste Stabilization Pond system.....	56
Table 16. List of suggested objectives and associated approaches, outcomes and assumptions to guide the technical feasibility study of wastewater-fed aquaculture at the Ruai Waste Stabilization Pond in Kenya. ....	66
Table 17. List of suggested objectives and associated approaches, outcomes and assumptions to guide the business model feasibility study of wastewater-fed aquaculture at the Ruai Waste Stabilization Pond in Kenya. ....	69
Table 18. Projected costs and revenues for an aquaculture enterprise in eight maturation ponds of the Ruai WSP, which serves the city of Nairobi, Kenya.....	70
Table 19. List of key institutional and research partners for implementing an aquaculture enterprise.....	72
Table 20. Price trend (Kenya Shilling) for 50 kg urea fertilizer in Kenya between 2000 and 2008. ....	73
Table 21. List of suggested objectives and associated approaches, outcomes and assumptions to guide the product development research for using urine as a fertilizer.....	75
Table 22. List of suggested objectives and associated approaches, outcomes and assumptions to guide the business model development research for using urine as a fertilizer.....	78
Table 23. Estimated scale of urine/nitrogen recovery possible from Ikotoilets in Nairobi .....	79
Table 24. List of key institutional and research partners for developing and implementing a urine-to-fertilizer business in Nairobi.....	80
Table 25. Current economics of the Peepoo-bag business model.....	83

## LIST OF BOXES

Box 1. Case study of community-scale struvite production from urine in Nepal.....	30
Box 2. Case study of fecal sludge land application practices in Tamale, Ghana.....	33
Box 3. Case study of using manure as a growth medium for culturing black-soldier-fly larvae.....	36
Box 4. Case study of biogas purification, compression and bottling for use in compressed natural gas (CNG) vehicles in India.....	43
Box 5. Case study of co-incinerating sewage sludge in a Chinese cement kiln.....	46
Box 6. Research Project to Watch: Fecal sludge-to-industrial fuel.....	47
Box 7. Research to Watch: Fecal sludge-to-briquettes.....	48
Box 8. Research Project to Watch: Fecal sludge-to-biodiesel.....	51
Box 9. Case study of wastewater-fed aquaculture in Ghana: the Waste Enterprisers model.....	54
Box 10. Research Project to Watch: Paying for wastewater treatment with wastewater irrigation....	57

# Chapter 1. Introduction

---

## 1. SCOPE OF WORK

The International Finance Corporation (IFC) in Kenya recently launched the Sanitation and Safe Water for All Program (SSAWA) to support market-based approaches to improving access to sanitation and safe water services and products. During the current phase of the SSAWA a core objective is to generate comprehensive market intelligence on the water and sanitation sector, which will support business entry and expansion and will inform the design of targeted business support activities under the program. In particular, activities being supported by the program are designed to identify market barriers and opportunities, and to support the private sector in developing business models with the potential to achieve significant scale.

Traditionally, sanitation entrepreneurs are classified under one of two typologies, those who provide sanitation services, such as building or emptying pit latrines, and those who make sanitation inputs, such as pedestals, slabs and soap [1]. This research, however, focuses on an emerging typology of sanitation entrepreneurs: *those who will use raw waste or the outputs of a treatment plant for productive and profitable purposes*. The resource value of human waste is significant and diverse, including the nutrients and water that can be used for irrigation, aquaculture or other non-potable purposes, and embodied energy that can be harnessed in the form of biogas or other fuels. Thus, fostering the emergence of sanitation entrepreneurs – or “back-end users” – simultaneously fosters financial and/or physical demand for waste that can incentivize and even help pay for alternatives to untreated discharge of excreta to the environment [2]. This approach to sanitation represents multiple paradigm shifts in the way that waste is typically handled and perceived (i.e. as waste) and in the way that sanitation is financed (i.e. through household user fees and/or government subsidies).

Though not yet proven at scale, waste-based business models appear to be a promising way to help finance portions of the sanitation value chain [3]. Strategically designed public-private partnerships and policies can ensure that a portion of revenues from such businesses goes toward the costs of collection, transport or treatment of wastewater/fecal sludge. For example, a fish farmer cultivating fish at a waste stabilization pond system could take over daily operation and maintenance of the treatment plant in exchange for access to the ponds and nutrient-rich water<sup>1</sup>. Likewise, a biogas producer could pay people

---

<sup>1</sup> This model is currently being piloted by Waste Enterprisers in Kumasi, Ghana.

to bring fecal sludge to his plant from the revenues generated by selling the gas (or added-value product) [3]. Indeed, these financial models represent a significant departure from the current but ineffective norm of depending on household user fees and government or donor subsidies to pay for complete sanitation [4]. Given the IFC's mandate and staff expertise, their SSAWA Program is well positioned to foster the growth, development, and mainstreaming of this novel approach to improving the efficacy and financial sustainability of complete sanitation.

To that end, this assignment comprises a comprehensive assessment of reuse options including existing and latent markets for wastewater and fecal sludge reuse in Kenya, with a geographic emphasis on Nairobi. The aims of the study were to do the following:

4. Synthesize technical and financial data on known reuse options for wastewater and fecal sludge;
5. Identify and outline business models that can elicit and foster viable private sector participation in sanitation;
6. Provide a description of institutional arrangements (public-private partnerships) that can foster win-win outcomes for the entrepreneur and sanitation sector; and
7. Outline waste-based business models that appear most promising for pursuit in the Nairobi region.

## **2. GEOGRAPHIC FOCUS OF STUDY**

The Republic of Kenya is located along the Indian Ocean and at the equator in East Africa (Figure 1). The country has an estimated population of 40 million of whom about 60% live in rural areas. However, given significant rural to urban migration, by 2015 50% of the population is expected to live in cities [5].

Nairobi is the capital city of Kenya and is the largest administrative, commercial, and industrial district in the country (Figure 1). Covering an area of 700 km<sup>2</sup>, Nairobi's current population is estimated to be 3 million and growing at a rapid rate of 6.9% per year. Over 50% of these residents lives in slums or other informal settlements [5].

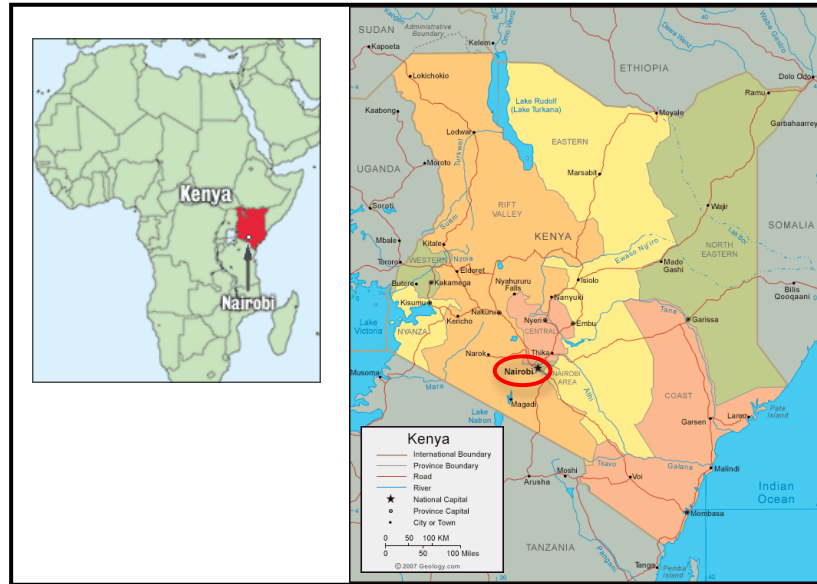

**Figure 1. Map of Africa with Kenya highlighted (Left) and map of Kenya with Nairobi circled (Right). (Sources: [www.globaleye.org](http://www.globaleye.org), <http://mapdelineationpic.co.cc>).**

### 3. METHODS

Findings and recommendations in this study derive primarily from desk research and professional experience of the author, along with face-to-face interviews in Nairobi. Background on Kenya’s sanitation status, key institutions, programs, and policies are based largely on documents published by local ministries and other active donors or support agencies. The summaries of wastewater and fecal sludge reuse options, as well as case studies, are drawn from peer-reviewed literature, grey literature, and professional experience. Final recommendations regarding waste-based business opportunities in Nairobi are based solely on preliminary data collection and discussions that took place over a span of six days in the city. Thus, any decision to pursue the development of one or more of the recommended waste-based business models in Nairobi (see Chapter 4) should begin with a more in-depth investigation of the enabling/constraining environments that will inevitably factor into the success of such a business. These next-step research needs are elaborated on in Chapter 4.

#### **4. OUTPUTS**

1. *Situation analysis of sanitation coverage and institutions in Kenya, with emphasis on policies and programs related to reuse;*
2. *Overview of fecal sludge reuse options and associated case studies; and*
3. *Business feasibility outlines for “best bet” waste-based businesses in and around Nairobi.*

# **Chapter 2. Sanitation Situation Analysis**

---

## **1. INTRODUCTION**

Successful support for the development of a “waste-based-business” sector in Kenya will only occur within the context of existing sanitation provision, policies and programs. Waste-based business models must be shaped with an understanding of existing social and cultural norms, consumer markets, and regulatory environments that impact entrepreneurs. Ultimately, the development of these businesses should be interwoven with on-going efforts to expand and sustain complete sanitation services across Kenya. This will ensure the emergence of businesses that are not only financially profitable but also active contributors to the environmental and public health objectives of the sanitation sector. Furthermore, actively engaging with national sanitation institutions will aid the technological and philosophical transfer of these businesses across Kenya.

This chapter comprises an overview of Kenya’s existing sanitation coverage and characteristics, institutional arrangements, key policies, short and long-term objectives, and on-going programs related to delivering and improving sanitation services. In particular, the extent to which any policies or programs can be leveraged to support or institutionalize reuse is highlighted. Likewise, any policies or programs that explicitly support private-sector engagement in sanitation are also noted.

## **2. SANITATION COVERAGE IN KENYA**

One familiar with cities in sub-Saharan Africa will quickly notice something unique about Nairobi: the absence of open drains in the planned sections of the city, and the paucity of cesspit emptying trucks among the traffic. Whereas 90% of African cities rely on on-site sanitation systems – ranging from pan latrines to flush toilets connected to septic tanks [6] – most households and institutions within the planned settlements of Nairobi are connected to a waterborne sewer network. That network carries wastewater to Africa’s second largest waste stabilization pond system in Ruai, about 25 km due east of the city center. Parts of western Nairobi have yet to be connected to the network. Thus, residents have septic tanks, and the exhausted waste is discharged into the sewer network and carried to Ruai. Nairobi is not only unique for Africa but even for Kenya. Nationwide, only 19% of the population is connected to a sewer network [7]. The most common on-site systems include ventilated improved pit latrines, traditional pit latrines, and waterborne systems that lead to septic tanks.



The informal settlements of Nairobi, such as Kibera and Mathere, present a very different picture of the city's sanitation system. In these areas, residents rely largely on shallow (unimproved) pit latrines, flying toilets, and open defecation. In Nairobi, 89% of low-income settlements use shallow pit latrines [7]. Lack of improved sanitation in public places and institutions, including schools, is held out as another major sanitation challenge in Kenya [7]. However, public sanitation is slowly improving thanks to the emergence of Ecotact, a private company that has built hygienic pay-to-use public toilet blocks in 12 municipalities across Kenya (See: [www.ecotact.org](http://www.ecotact.org) and further discussion of the company in Chapter 4).

Average national sanitation coverage in Kenya is estimated at 52.5% based on the results of five surveys that ranged from 46% to 68% having access [5]. Getting consistent and reliable results from such surveys is notoriously difficult due to differences in definitions of "access to sanitation" and the evolving status of existing sanitation facilities. Among the population defined as having access to sanitation, more than 50% lack appropriate collection and treatment of wastewater and/or fecal sludge [7]. By some estimates, 95% of excreta is discharged into the environment without any treatment [7]. In fact, a recent survey of 43 wastewater treatment plants operated by Water Service Providers found that only 3% met effluent quality standards [7]. In cities and towns that use waterborne systems, intermittent water supply often leads to overloaded, blocked, and bursting pipes [7].

The public health impacts of Kenya's weak sanitation coverage are enormous. At any given time, half of the hospital attendance in Kenya is due to water, sanitation and hygiene related illnesses [8]. Freshwater resources are becoming increasingly contaminated and stress on water supply is further exacerbated by the current isolation of water resources management and the sanitation sector [7].

### **3. INSTITUTIONAL ARRANGEMENTS AND COORDINATION**

The Kenya Vision 2030 and Kenya's Medium Term Plan 2008-2012, both released in 2007, have brought sanitation to the fore by emphasizing its importance as a catalyst for Kenya's economic growth and development. Historically, sanitation garnered limited attention, but recent reforms aim to reverse the environmental and public health damages that result from inadequate sanitation. A dedicated Ministry of Public Health and Sanitation (MoPHS) was established in

2008 to replace the Ministry of Health as the institution in charge of coordinating the sanitation sector – appreciably elevating sanitation’s institutional significance. The MoPHS is charged with integrating all actors in the sanitation sector, implementing the National Sanitation and Hygiene Policy, and with chairing the Environmental Sanitation and Hygiene Working Group, which is a consortium of 30 stakeholders that has a planning, coordination and advisory role over the sector (Table 1).

The MoPHS works in close coordination with the Ministry of Water and Irrigation, which is responsible for expanding water and sanitation coverage and for monitoring and managing water resources. At the regional level, the Water and Sanitation Boards (WSBs) are to be involved whenever sanitation assets enter their asset register. And at the local level the key actors include water service providers (WSPs)/utilities, other private sector actors and NGOs.

Table 1 provides a summary of the core actors at the national, regional and local levels.

**Table 1. Summary of actors at the national, regional and local levels in Kenya’s sanitation sector.**

<b>INSTITUTION</b>	<b>ROLE</b>
	<i>National level</i>
Ministry of Planning and Vision 2030	National development policy, planning and monitoring (e.g. progress toward MDGs)
Ministry of Public Health and Sanitation (MoPHS)	Established in 2008. Responsible for overall coordination and integrations of actors in the sanitation sector; Implementation of National Environmental Sanitation and Hygiene Policy; Setting monitoring standards for household sanitation Lead role in mobilizing financial resources for sanitation, including budgetary allocations and donor assistance. Chair of the ESHWG
Environmental Sanitation and Hygiene Working Group (ESHWG)	Chaired by the MoPHS, includes 30 organizations that meet quarterly and are responsible for coordination and advising. Tasked with developing strategies and programs and seeking funding
Ministry of Water and Irrigation (MWI)	Oversight of sewer systems and appropriate technology intervention; Setting standards for appropriate collection and treatment of wastewater and fecal sludge
Ministry of Local Government	Facilitating and supporting local-level authorities
National Environmental Management Authority (NEMA)	Implementation of environmental protection policies; Setting effluent discharge standards
Ministry of Public Works	Construction and maintenance of WWTPs in public institutions
Water Services Regulatory Board (WASREB)	Provide incentives for Water Service Providers to be involved in sanitation; Development of subsidy concept for sanitation
Water Services Trust Fund (WSTF)	Provide urban WSPs and rural community organizations with funds for sanitation
Kenya Water Institute (KWI)	Training in ecosan and other sanitation technology for water sector institutions; Research on appropriate sanitation technologies and construction of demonstration facilities
	<i>Regional level</i>
Municipalities	Construction and maintenance of wastewater collection and treatment systems; Enforcement of sanitation by-laws

<i>Local level</i>	
Water Service Providers (WSPs) and other private actors	Aid construction of sanitation facilities funded by WSTF; Operate public sanitation facilities; Encouraged to invest in sanitation services and to introduce affordable and modern technology
Community-based organizations (CBO)	Conduct sanitation awareness and education campaigns; Training sanitation entrepreneurs

Local ministries and supporting organizations have published several documents that provide detailed overviews of the institutional mandates and current policies and programming of actors in Kenya’s sanitation sector. Prominent among these documents are the Ministry of Water and Irrigation’s *Implementation Plan for Sanitation – The Water Sector Sanitation Concept* (2009), the Ministry of Health’s *National Environmental Sanitation and Hygiene Policy* (2007), the Ministry of State for Planning and National Development’s *Kenya Vision 2030: Transforming National Development* (2007), and the Water and Sanitation Collaborative Council’s *Sanitation Sector Status and Gap Analysis: Kenya* (2009). The key points from each are distilled in Table 2, and readers are referred to the original documents for further details.

**Table 2. Vision, goals and activities laid out in key documents shaping Kenya’s sanitation sector.**

DOCUMENT	VISION & GOALS	ACTIONS & ACTIVITIES
<b>Kenya Vision 2030 (2007)</b>	<p><i>Vision</i> To transform Kenya into a newly industrializing, middle-income country providing a high quality life to all its citizens by the year 2030</p> <p><i>Goals</i> <u>Economic Pillar:</u> To achieve an average annual GDP growth rate of 10% <u>Social Pillar:</u> To build a just and equitable society and a clean and secure environment <u>Political Pillar:</u> To achieve a democratic political system that respects the rule of law and protects individuals’ rights and freedoms</p>	<ul style="list-style-type: none"> <li>•Recognize water, sanitation and hygiene as catalysts for economic development</li> <li>•Rehabilitate and build sanitation systems in satellite towns</li> </ul>
<b>National Sanitation and Hygiene Policy (2007)</b>	<p><i>Vision</i> To create and enhance an enabling environment for improving hygiene and sanitation in Kenya</p> <p><i>Goals (met by 2015)</i> 1. All households aware of importance of sanitation 2. 90% of households have access to improved toilet facility 3. 90% of households have access to safe drinking water and safe waste disposal by 2015; 100% of school have access to hygienic toilets and hand-washing facilities</p>	<ul style="list-style-type: none"> <li>•Promote sanitation, not by subsidizing the sector but through awareness campaigns, encouraging households to invest in own sanitation, etc.</li> <li>•Operationalize defined roles of different actors and institutions</li> <li>•Establish a Trust Fund to enable fulfillment of policy goals</li> <li>•Emphasize maintenance (not just construction) of sanitation facilities: e.g. long-term service delivery plans in urban areas, community buy-in</li> </ul>

---

<b>Implementation Plan for Sanitation (2009)</b>	<p><i>Vision</i> To help give sanitation in the water sector the same importance and priority that it receives in the Kenya Vision 2030 and Medium-Term Plan.</p> <p><i>Goals</i></p> <ol style="list-style-type: none"> <li>1. Put sanitation higher on the agenda</li> <li>2. Increase sanitation coverage</li> <li>3. Enhance cooperation with other sectors on sanitation</li> <li>4. Improve enforcement of sanitation standards</li> <li>5. Improve collection and treatment of sewage; Promote economic and social benefits of wastewater</li> <li>6. Mobilize increased funds for sanitation</li> <li>7. Ensure proper response to sanitation in emergencies</li> </ol>	<p>and participation</p> <ul style="list-style-type: none"> <li>•Promote on-site sanitation for reaching large numbers</li> <li>•Target high-density settlements,</li> <li>•Favor reuse-oriented systems, including biogas, fertilizer, irrigation water</li> <li>•Seek to outsource operation of large facilities and on-site systems to the private sector</li> <li>•Give Ministry of Public Health and Sanitation mandate for leadership of sector</li> <li>•Seek to transfer lessons and approaches from recent and successful water sector reforms</li> </ul>
--	---	--

---

#### 4. PRESENCE OF REUSE AND THE PRIVATE SECTOR WITHIN SANITATION POLICY & PROGRAMMING

“[S]afe sanitation requires safe disposal, treatment and **reuse of effluent** which shall be taken into consideration when counting coverage. It is **insufficient when users can access well-constructed facilities in a safe way but individual and public health is no longer guaranteed because of inadequate disposal** of effluent and flooding of facilities, contaminating the water sources by neighbouring settlements.”

Ministry of Water and Irrigation, (2009) Implementation Plan for Sanitation, p 27.  
(Boldface added for emphasis)

Reuse, as an approach to sanitation, is highly visible in the sector literature. The MWI’s Implementation Plan, for example, states that facilities receiving high volumes of effluent should be “designed for the reuse of effluents to produce biogas, fertilizers, and water for irrigation to protect the environment and generate the advantages of sanitation for production,” (p 8). The Plan goes so far as to say that Africa should aim to replace the use of chemical fertilizers with wastewater effluent, and that Kenya should spearhead this movement. Less lofty aspirations for reuse include the plan to build at least 30 sanitation facilities at public places that are constructed for reuse, including biogas and/or fertilizer, 10 reuse-oriented facilities for public institutions, and 1000 rural-household-level sanitation systems designed for reuse of feces and urine. These facilities are to be financed by the Water Services Trust Fund. No doubt, reuse, for the purpose of environmental protection and resource conservation, is a reoccurring theme throughout the Implementation Plan. But so too is the acknowledgement that sector actors still need the know-

how and management concepts to take advantage of human waste as a resource. In practice, it is not clear that the MoPHS (the implementing agency) has a real strategy for incorporating reuse into the sanitation sector.

Increasing the role of the private sector across the sanitation value chain (i.e. from the provision of toilet facilities, to the implementation, operation and maintenance of treatment plants) is also a prominent component of the MWI's Plan. A specific goal is to outsource the operation of sanitation systems – on-site systems and large-scale treatment plants alike – to private actors. These actors would largely represent a cohort of new entrepreneurs to the sector, as most existing water service providers lack the appropriate expertise to expand their scope to sewage network and treatment plant management [7].

Of course, effectively attracting entrepreneurs/private companies to sanitation comes down to establishing favorable (not to mention logistically viable) public-private-partnership (PPP) schemes and demonstrating the financial viability of these investments. The MWI is to work with the Water Services Regulatory Board to foster an enabling environment for PPPs, the details of which have not been spelled out. Regarding finance, the Implementation Plan adopts a user-fee-based cost-recovery strategy, whereby households are expected to bear the costs of treatment (and collection in the case of on-site systems). However, one of the biggest shortcomings with this financial model is that the Plan rightly acknowledges that 50% of households in Nairobi simply cannot afford to pay for sanitation services [7]. Thus, private sanitation providers/plant operators risk walking into a bankrupt system or having to bias their services against low-income communities.

While reuse and private sector engagement are both reoccurring themes in Kenya's sanitation policies and programming documents, the two are almost always discussed in isolation of one another. However, the best opportunities and outcomes from either one of these pursuits may emerge by coupling efforts at promoting reuse and private-sector participation in sanitation. Reuse has far more to offer to the sanitation sector than the indeed important cause of environmental protection, for which it is being promoted in Nairobi. In fact, reuse may be the linchpin for increasing the role of private actors and for improving the financial solvency of the sanitation sector. As this report argues, aggressively developing a waste-based business sector would present enticing opportunities for entrepreneurs and stimulate a demand for human waste that can incentivize alternatives to haphazard disposal. Furthermore, if sanitation planners and

the appropriate government institutions are involved in developing the sector, they can craft PPP models that ensure a portion of financial benefits from reuse go toward costs that accrue across the sanitation value chain.

# Chapter 3. Productive Use of Human Waste: A Global Overview

---

## 1. INTRODUCTION

Despite being thought of as an urgent disposal problem, human waste has vast and diverse potential for resource recovery (Table 3). Agricultural irrigation is the oldest form of wastewater reuse, its history dates back 5000 years to the Minoan Civilization in ancient Greece, and it remains ubiquitous in developing and developed countries [9]. Land application of treated sludge is also widely practiced in many regions of the world, including in the US, where about 45% of “biosolids” (the term used in the US for treated sewage sludge) are applied to land [10]. The use of treated sludge as a soil amendment for agriculture, forestry, or urban landscape is subject to meeting heavy metal and pathogen standards, and where sludge is applied to edible crops – particularly those eaten raw – even stricter standards apply. Applying sludge to land is an effective way of utilizing the resource value of nutrients in the sludge.

While reuse opportunities for human waste may have started with agriculture they do not end with agriculture. The energy potential of wastewater and fecal sludge is also significant. Harnessing embodied energy via anaerobic digestion to produce biogas is the most common approach, but other emerging technologies entail burning it as an industrial fuel and using it as a feedstock to make biodiesel (Table 3).

**Table 3.** Resources available in various mediums of human waste, associated productive uses, and potentially marketable products.

Waste Medium	Resource (“input”) of primary value	Qty input/person-equiv./yr	Productive use category	Productive use specific	Marketable products associated with reuse
Urine	nitrogen	2 kg N (Langergraber 2005)	agriculture	fertilizer	<ul style="list-style-type: none"> <li>• processed urine to farmers</li> <li>• crops to consumers</li> <li>• crops to consumers</li> </ul>
Raw fecal sludge	nitrogen, org. carbon	0.34 m <sup>3</sup> FS at 5% dry solids (assumes 1 part public toilet at 100 g/TS-cap-d and 2 part septic sludge at 20 g TS/cap-d)	agriculture	fertilizer & soil conditioner	
Raw fecal sludge	carbon		domestic/industry	household biogas	<ul style="list-style-type: none"> <li>• NA (biogas used by household)</li> </ul>
Raw fecal sludge	carbon	0.73 m <sup>3</sup> (Volume of urine, water, feces generated in pour-flush toilets using 2 L water/flush) (EAWAG/SANDEC 1998)	domestic/industry	community biogas	<ul style="list-style-type: none"> <li>• biogas as cooking fuel to households/restaurants</li> <li>• electricity produced from biogas to households/enterprises</li> <li>• biodiesel to large-volume users, refineries</li> </ul>
Raw fecal sludge	organic matter		domestic/industry	feedstock for biodiesel	<ul style="list-style-type: none"> <li>• black soldier fly larvae as feed to fish and/or poultry farmers</li> </ul>
Dewatered fecal sludge	nutrients, organic matter	100 kg (at 70% dry solids) (EAWAG/SANDEC 1998)	agriculture	growth medium for black soldier fly larvae	<ul style="list-style-type: none"> <li>• dewatered fecal sludge to farmers</li> <li>• crops to consumers</li> </ul>
Dewatered fecal sludge	carbon		agriculture	soil conditioner	<ul style="list-style-type: none"> <li>• partially dried fecal sludge as fuel to industries</li> </ul>
Dewatered fecal sludge	carbon	260 MJ (assumes 1 part public toilet at 100 g/TS/p.e./d and 2 part septic sludge at 20 g TS/p.e./d; Assumes 15 MJ/kg DS (Fyttili and Zabaniotou 2008))	domestic/industry	solid fuel	
Co-composted fecal sludge	carbon	69 kg mature compost (Cofie and Kone 2009)	agriculture	soil conditioner	<ul style="list-style-type: none"> <li>• compost to farmers, developers, etc.</li> <li>• crops to consumers</li> </ul>
(Un)treated wastewater	water, nutrients if undiluted		agriculture	irrigation	<ul style="list-style-type: none"> <li>• wastewater to farmers</li> <li>• crops to consumers</li> </ul>
Wastewater (partially treated)	water, nutrients	26 m <sup>3</sup> (assumes 85 L/p.e./d and 85% return as wastewater)	agriculture	aquaculture	<ul style="list-style-type: none"> <li>• maturation pond<sup>a</sup> access to fish farmer</li> <li>• fish to consumers (people, animal feed producers)</li> </ul>

<sup>a</sup>The final pond(s) in a waste stabilization pond system, which provide tertiary treatment.



An important consideration in determining the logistical and financial viability of any reuse is the local market demand for that product compared to the expected supply of a given product of reuse. In other words, assuming a certain excreta-generating population, one must consider the required receiving capacity of the end user – i.e. in the form of land area or fuel demand – to absorb the supply of a product of reuse. Based on an excreta-generating population of 100,000 people, Murray et al. estimated the necessary receiving capacities for various reuses as shown in Figure 2 and Table 4 [11]. Murray et al.'s estimates for agricultural land area requirements are based on norms for Ghana and of course, fertilizer and compost application rates can vary dramatically based on soil conditions, climate, and crop type, among other variables.

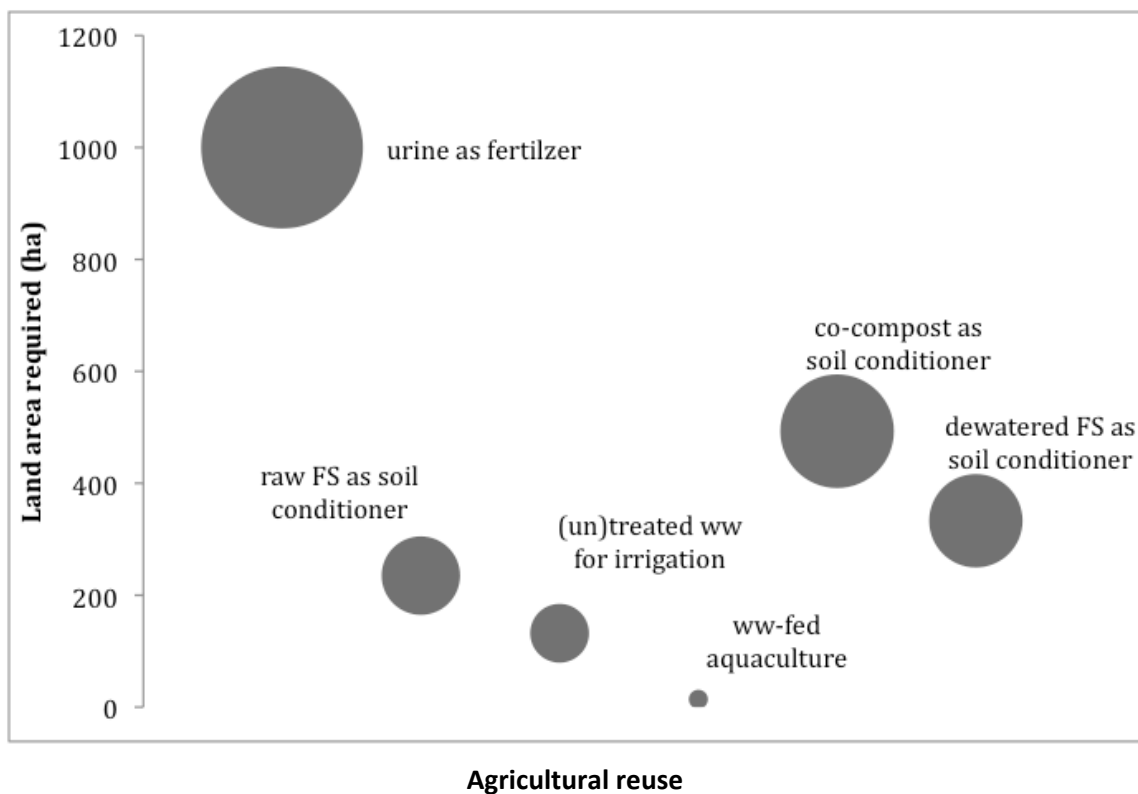

Figure 2. Land area required for agricultural reuse of different waste streams generated by 100,000 peron-equivalents/yr. Land area for wastewater assumes three crop cycles/ha.yr; urine assumes two crop cycles/ha.yr; raw FS (fecal sludge), dewatered FS and co-compost assume one application/ha.yr. (Source: Murray et al. 2011).

**Table 4.** Comparison of receiving capacity of end users for various energy endpoints for fecal sludge (FS). Community-level biogas and dried FS for fuel assume the volume of FS generated by 100,000 person-equivalents. (Source: Adapted from Murray et al. 2011).

<b>Medium and reuse</b>	<b>Receiving capacity of end user</b>	<b>Production equivalent</b>
FS for household biogas recovery	$\geq 1.2 \text{ m}^3$ biogas demand/d	~1.5 hr cooking on gas burner (Jha year unknown)
FS for high density community biogas recovery	$\geq 1200 \text{ m}^3$ fuel demand/d or $\geq 125 \text{ KW}$ electricity demand/d	860 hh cooking for 2 hr; or 50 street lanterns of 40-watt-bulb-eq burning 8 hrs) (Jha year unknown)
Dried FS for fuel	$3.7 \times 10^5 \text{ MJ/d}$ fuel demand	~90 tons clinker <sup>a</sup> -eq (Murray and Price 2008)

<sup>a</sup>Clinker is a mixture of limestone, clay, and oxides, which is pyroprocessed with gypsum in kilns to produce cement.

Assuming that the necessary receiving capacity for a given product of reuse can be met, Murray et al. quantified the economics associated with various means of capturing the resource value of a given waste stream (Table 5). Like their estimates for receiving capacity, the values are representative of the Ghanaian context and are based on several assumptions that may vary from one context to another (See Appendix 1 for detailed list of data, assumptions and sources). Thus, the results are most useful for comparative rather than definitive purposes.

**Table 5.** Economics associated with different productive-reuse options for waste streams generated by 100,000 pe/yr. Capital costs assume a one-time outlay; all other costs and revenues are on an annual basis. The productivity change approach data used to calculate the incremental benefit are only partially comparable as they use different baselines. (Source: Adapted from Murray et al. 2011).

Medium & reuse	Capital costs linked to reuse (\$)	O&M costs linked to reuse (\$)	Hypothetical market value of input (\$)	Incremental benefit (\$)	Sources for input data
Urine	3,750,000 (\$150/hh for UDDT) + 6,000 (urine storage)	660,000	240,000	600,000	(Schroder 2010, Fall 2009, Germer and Sauerborn 2006)
Raw fecal sludge as fertilizer/soil conditioner	0	0	326,000	458,000	(Adamtey Submitted 2010)
Raw fecal sludge for household biogas recovery	8,750,000 (\$350/hh)	~0	4,811,000 (~\$200/hh.yr)	NA	(DevPart-Nepal 2001, Winrock International 2004)
Raw fecal sludge for community biogas recovery (gas and elec., respectively)	983,000 1,045,000	43,000 47,000	193,000 76,000	NA	Private Ghanaian contracting firm; Ghana Energy Foundation
Dewatered fecal sludge (as soil conditioner)	65,000	11,000	73,000	472,000	(Cofie and Kone 2009, Zurbrugg et al. Unpublished manuscript, Fytli and Zabaniotou 2008, Adamtey Submitted 2010)
Dewatered fecal sludge (as fuel)	65,000	12,000	335,000	NA	(Cofie and Kone 2009, Zurbrugg et al. Unpublished manuscript, Fytli and Zabaniotou 2008)
Co-composted fecal sludge	93,000	168,000	518,000	880,000	(Cofie and Kone 2009, MLGRD and EHSD 2010, Adamtey Submitted 2010)
On-farm-treated wastewater for irrigation	75,000	110,000	NA	559,000	(Seidu and Drechsel 2010, Danso et al. 2006)
Partially treated wastewater for aquaculture	14,000,000 (WSP) + 1000 (aq-specific)	150,000 (WSP) + 54,000 (aq-specific)	NA	220,000	(von Sperling and Augusto de Lemos Chernicharo 2005, Murray 2010)
Treated wastewater for irrigation	14,000,000 (WSP) + conveyance costs	150,000	52,000	559,000	(Bahri 2009, Danso et al. 2006)

With that overview of the technical and financial constraints and opportunities associated with reuse, the remainder of this chapter comprises detailed summaries and case studies of each of the reuse options shown in

Table 3. The sections are organized by waste medium, beginning with urine, followed by fecal sludge, and finally wastewater.

## 2. URINE USE: SUMMARY AND CASE STUDY

Urine is a nutrient-rich waste stream that has potential to be captured, processed and sold as a replacement for NPK fertilizer. In fact, urine typically comprises only 1% of a wastewater stream but contains 87% of the nitrogen, 50% of the phosphorus, and 54% of the potassium [12]. Table 6 shows the average concentrations of each nutrient in urine and the average annual human excretion.

Despite its high nutrient value, the fact that urine is usually mixed with water and feces is a major barrier to its recovery. Mixing not only dilutes the nutrient value of urine but also contaminates the urine with pathogens, which primarily originate from feces. Urine-diverting (dry and waterborne) toilets have been developed, making it possible to separate urine from flush water and feces, but they are far from mainstream. These urine-diverting toilets are a form of what is called ecological sanitation – or “Ecosan” – because they are designed to foster the reuse of urine as fertilizer and the separate collection and composting of feces as a soil enhancement.

With the appropriate toilet technology in place, one major advantage to urine recovery (compared to recovering nutrients from mixed waste streams and/or feces alone) is that urine is sterile in most healthy individuals. A storage period of just one month is considered sufficient to ensure the complete absence of pathogens when urine is being collected and distributed on a community or city scale. Odor, which originates from the ammonia content, will persist and concentrate upon storage but dissipates quickly after application and tilling into the soil.

**Table 6. Average nutrient concentrations in urine.**  
(Source: reproduced from Germer et al. 2009)

	Quantity (g/L)	Annual quantity (kg/person/yr)
--	----------------	--------------------------------

---

Nitrogen	7	3.5
Phosphorus	1	0.5
Potassium	2	1.0
Sulfur	1	0.5
Magnesium	0.08	0.04
Calcium	0.2	0.1

---

In part because there are so few large-scale implementations of urine-diverting toilets, urine recovery as fertilizer has yet to be demonstrated as a commercially viable enterprise. However, a number of smaller scale projects have piloted different means of capturing, processing and applying urine to agricultural fields. Direct application, whereby the urine is stored, diluted with water at a ratio of 1:3 to 1:5 and applied to fields, is the simplest approach. The West African Centre for Low Cost Water Supply and Sanitation (CREPA) led a three-year pilot project in this vein outside of Ouagadougou, Burkina Faso (2006-2009) (see the SuSanA case study for more information: <http://www.susana.org/lang-en/case-studies?view=ccbkttypeitem&type=2&id=84>). More sophisticated urine-processing options include precipitation of the nutrients to produce struvite powder. The latter is of course more expensive but may ultimately be more commercially viable because the product is easier to market and transport (Box 1).

**Box 1. Case study of community-scale struvite production from urine in Nepal: A synopsis of the STUN (Struvite recovery from Urine in Nepal) project.**

**Reuse practice.** Approximately 500 Ecosan toilets have been built in peri-urban towns in the Kathmandu Valley, Nepal. In the district of Siddhapur, Eawag and UN-HABITAT supported a pilot project (STUN) that entailed collecting the separated urine to produce struvite for local agriculture [13, 14]. The goals of the project were to understand the technical feasibility and economic viability of producing struvite as a business.

Struvite ( $MgNH_4PO_4 \cdot 6H_2O$ ) is a white odorless solid that precipitates naturally from urine when magnesium is added. Among the various technologies for extracting nutrients from urine, struvite production is among the simplest and is an especially effective way to capture the phosphorus content. With the addition of magnesium cations ( $Mg^{2+}$ ) at a molar concentration of 108%, researchers achieved 93.6% fixation of phosphorus [14]. On the other hand, 95% of the nitrogen remains in the liquid effluent [14].

During the project, urine was collected from households in 20-L jugs and transported to a central facility. Magnesium was sourced locally. In fact,  $MgCl_2$  and  $MgSO_4$  are marketed as fertilizers in many places and are among the most desirable sources of magnesium for making struvite because they are highly soluble, the byproducts ( $Cl_2$  and  $SO_4$ ) do not compromise the quality of the process effluent as a fertilizer, and because they tend to be widely available [14]. Another favorable source of magnesium is bittern, a byproduct of salt production, which has a relatively high magnesium concentration that is already in solution.

Researchers produced struvite in a tank equipped with a mechanical mixer and a filter made of mono-filament nylon fabric (Figure 2). The optimal stirring time was determined to be ten minutes followed by a 24-hr settling period to collect the struvite precipitate [13].

**Investment requirement.** The first requirement is a critical mass of urine-diverting toilets from which to collect urine. Assuming those are in place, the costs incurred for collection and production of struvite in Nepal are reported in Table 7.

**Table 7. Capital costs associated with struvite production in Nepal. (Adapted from Etter 2009).**

Component	Cost (USD)
<i>Urine collection and storage</i>	
transport tanks (2 x 40 L) and trays bicycle	21
	49
<i>Struvite production</i>	
500 L tank	56
stirring mechanism and filter tray	210
1000-L tank for storage	112
pipes and fittings	28
effluent storage tank (500 L)	112

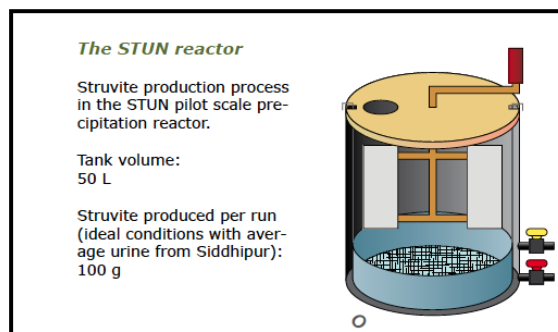

**Figure 3. Schematic of struvite production reactor designed by the STUN project.**

**Box 1. (Cont.)**

**Cost recovery.** At the scale of the community project conducted in Nepal, struvite production was not commercially viable. However, it should be emphasized that very few projects have been conducted, even at a pilot scale, so there is indeed scope for further streamlining costs, introducing additional revenue sources (e.g. packaging and sale of the process effluent, which contains most of the nitrogen), taking advantage of economies of scale, and/or enacting policies that would make the process commercially viable.

As shown in Table 8, the value of struvite as a fertilizer in Nepal (using the replacement cost approach) is (coincidentally) equal to the cost of  $MgSO_4$  required to produce the struvite, assuming no value is attributed to having magnesium in the fertilizer product [14]. In regions where there is a market for magnesium fertilizers, struvite can enjoy a nominally higher market price (Table 8). But even then, once the costs of collection, construction of the reactor, electricity for operating the reactor, labor, and marketing and distribution of the struvite are accounted for, the system would be operating at a financial loss.

**Table 8. Economics of struvite production under prevailing market conditions in Siddhipur, Nepal. (Adapted from Ghantenbein and Khada 2009).**

Product	Quantity	Value (USD)
Collected urine (m <sup>3</sup> )	1	-
Struvite (kg/m <sup>3</sup> urine)	1.9	1.1 (including value of magnesium) 0.7 (magnesium not attributed any value)
Magnesium sulfate needed for precipitation (kg/m <sup>3</sup> urine)	2.2	0.7

**Occupational risk.** As discussed above, urine is usually sterile when it leaves the body. With some additional modest barriers in place to prevent workers from coming into direct contact with fresh urine (i.e. gloves, face mask) the occupational risks should be extremely limited.

**Consumer risk.** Assuming the struvite solids are dried prior to distribution and sale, any remaining pathogens should be completely inactivated.

**Potential for scale.** The biggest barrier to scale is the dearth of urine-diverting toilets, which are essential to make urine recovery possible.



### **3. FECAL SLUDGE USES: SUMMARIES AND CASE STUDIES**

Based on the options presented in Table 3, this section summarizes productive uses for FS, beginning with agricultural endpoints and moving on to energy-related uses.

#### *3.1 Land application of raw/dewatered/treated FS as a fertilizer and soil conditioner*

Land application of sludge is practiced widely in many regions of the world; in the US, about 45% of “biosolids” (the term used in the US for stabilized sewage sludge) are applied to land [10]. In countries where environmental regulations are enforced, the use of treated sludge as a soil amendment for agriculture, forestry, or urban landscape is subject to meeting heavy metal and pathogen standards. Where sludge is applied to edible crops – particularly those eaten raw – even stricter standards often apply.

In many developing countries it is common for FS to be applied to agricultural land after little or no treatment. For example, farmers in Tamale (northern Ghana) receive sludge on their land directly from cesspit trucks (Box 2).

FS is very rich in nutrients and organic matter and is thus attractive to farmers as a supplement or replacement for commercial fertilizers. Table 9 provides some representative values of the nutrient content of different types of sludge. As shown, FS tends to have a significantly higher nutrient content than sewage sludge that is generated by conventional wastewater treatment processes.

## **Box 2. Case study of fecal sludge land application practices in Tamale, Ghana.**

**Reuse practice.** In Tamale, Ghana, FS is collected from on-site sanitation systems by cesspit emptiers and discharged onto farmers' fields. The farmers have devised methods for handling and applying FS to the soil that take advantage of the region's high temperatures for inactivating pathogens in the FS. FS is only discharged onto the farms during the dry season and after a drying period of several weeks to months, the sludge is easy to handle and can be incorporated into the soil at the beginning of the rainy season.

Farmers have two methods of utilizing the FS: surface spreading and the 'pit' method. Surface spreading involves discharging the FS at various places on a farmer's plot. At the end of the dry season, the farmer gathers and redistributes the material evenly on the field. Alternatively, the pit method involves digging pits on the farmland and placing straw or bran at the bottom of the pit. FS is then poured into the pit, which is large enough to contain several trucks worth of FS. Layers of bran and straw are placed in between subsequent trips. The full pit is left to compost for several months and before the cropping season starts, it is emptied and the dry mixture of FS and straw is applied evenly on the field.

**Investment requirements.** There is no additional required infrastructure beyond cesspit emptiers (i.e. vacuum trucks for transporting FS from cesspits/latrines to farmland). The primary cost of implementing this form of reuse is training farmers to employ safe FS handling practices.

**Cost recovery.** In Tamale, farmers' net revenues average three-fold greater for those using FS than those not. The revenue increase is due to the combination of increased yields and cost savings on fertilizer. Farmers in Tamale do not pay for the FS but it may be plausible for cesspit emptiers to charge a fee, which could be used to subsidize the cost of cesspit emptying, particularly in low-income areas.

**Occupational risk.** FS contains a high pathogen load; however, the methods of use – surface spreading and the pit method – help control those risks. Some farmers have experienced skin irritation after spreading the FS on their fields but they were not wearing protective clothing.

**Consumer risk.** Restricting land application of FS to the dry season, and then having an extended drying period prior to spreading the FS across fields, facilitates pathogen inactivation and consumer risk reduction. However, these methods do not ensure complete pathogen removal, and they can be rendered less effective if not carried out according to best practices.

**Potential for scale.** Land application of FS is socially accepted in Tamale and many other regions; its effect on yields and cost-savings no doubt enhance its desirability. The main constraints to scale-up are availability of land, temporal demand for fertilizer, and the fact that it can only be practiced during the dry season with adequate time for drying before the rains.

In spite of the many benefits of land application of sludge, there are public health, environmental, and logistical constraints that may make it difficult to employ land application as the sole sludge management strategy in many regions. As alluded to in the Tamale case study (Box 2), applying sludge to land during rainy seasons can lead to excessive run-off of nutrients into surface waters. Thus, under such climate conditions sludge must be stored or alternatively managed. Furthermore, the amount of FS that can be applied to a parcel of land is usually restricted to protect the health and safety of people and the environment. For example, South Africa's application limit is 10 dry ton (DT) per hectare per year and China's limit is 30 DT per hectare per year. However, based on agricultural nutrient demands and research projects comparing yields from various application rates of raw, dried and composted sludge, the following rates are recommended and to some extent practiced by farmers: 52 m<sup>3</sup> per hectare raw FS; 7 ton per hectare dried FS; 14 ton per hectare composted FS [15-17].

**Table 9. Typical nutrient content of sewage and fecal sludges from different geographic regions.**

Nutrient content as % of dry solids	Sludge generated by wastewater treatment processes <sup>a</sup>		Fecal sludge <sup>b</sup>
	Average in US and UK	Average in China	
N	2.8	2.5	9-12
P	1.6	1	3.8 (as P <sub>2</sub> O <sub>5</sub> )
K	0.3	0.7	2.7 (as K <sub>2</sub> O)

<sup>a</sup>Source: Wang 1997 [18]; <sup>b</sup>Source: EAWAG-SANDEC 1998 [19].

### 3.2 FS as a medium for black soldier fly larvae production (alternative fish/poultry meal)

Conversion of organic refuse by saprophages (CORS) is a decades old practice. The most common example is vermicomposting, or the use of worms to convert organic waste to nutrient-rich humic matter. Black soldier fly (BSF) (*Hermetia illucens*) larvae, which are indigenous to the southern USA but prevalent throughout the tropics and subtropics between 45° N and 40° S, have been employed for degrading livestock manure, and then harvested as feed for poultry, pigs and fish [20]. To date, most BSF systems have been high cost and complex to maintain, and their application has been limited to developed countries [20]. However, researchers have recently begun to explore the possibility of using BSF systems for solid and human waste management in developing countries [20, 21]. Unlike house flies, adult BSFs do not feed, and are not attracted to food or human habitats, thus do not pose a threat as a vector of disease transmission [22].

BSF-larvae-based systems for managing human excreta have not been tried at scale, but the waste conversion rates that have been achieved in pilot experiments, and the market potential of mature

larvae as fishmeal, suggest that this technology could have promise. Several recent studies have examined the potential for BSF larvae to thrive on and reduce human fecal sludge. Based on pilot-scale feeding experiments using chicken feed, Diener et al. projected that BSF larvae can digest 130 mg human feces/larva/day, allowing for a feces loading rate of 6.5 kg per m<sup>2</sup> per day at a density of 50,000 larvae per m<sup>2</sup> [20].

In a follow-up study in Costa Rica, these researchers found that BSF fed at a rate of 167 mg FS/larva/day reduced the FS by 54.7 dw% after 27 days [23]. Affiliated researchers conducted another study in Thailand comparing BSF conversion of four waste streams, including FS. They found that BSFs could reduce the dry mass of fecal sludge by 52-59% after 21 and 27 days of feeding, respectively [21]. They identified a relatively low optimal feeding rate, finding that 50 mg FS/larva/day corresponded to a higher FS consumption rate compared to rates of 100 mg and 150 mg/larva/day [21]. Both the Costa Rican and Thailand studies found that when FS was mixed with organic solid waste in a 1:1 ratio, consumption levels increased dramatically, achieving 66% reduction in dry mass of the waste after just 18 days [21, 23]. Furthermore, the prepupal dry weight was more than double that of larvae fed on pure fecal sludge, thus improving their quality as animal feeds.

BSFs are known to be hardy organisms, though their ability to thrive and effectively consume fecal sludge can be compromised by certain physical or chemical factors. One key to the success of BSF systems is having the proper climate conditions. BSFs lay eggs in the temperature range of 27.5° – 37.5° C [24]. Humidity is also a factor, as BSF larvae start losing 1% of their weight per hour at levels at or above 75.5% [21]. BSF larvae can cope with oxygen depletion and food shortages but completely anaerobic conditions, extreme temperatures or elevated heavy metal concentrations can devastate a BSF-larvae population [23]. Wiping out the population would not only compromise the treatment process but assuming the larvae are being sold as fish/poultry feed, the revenue stream that keeps the system in place would also be ruined. Before a commercial-scale system is implemented it will be useful to have better information on the best management strategies and environmental conditions for maintaining a healthy BSF population [23]. Box 3 summarizes the investment and cost recovery potential for using BSF in excreta management.

**Box 3. Case study of using manure as a growth medium for culturing black-soldier-fly larvae, an alternative fish and poultry feed.**

**Reuse practice.** Adult black soldier fly colonies are maintained in a dedicated colony. Fresh larvae, at a density of 85,000-100,000/m<sup>2</sup>, are moved to a swine-manure collection basin directly below the pigs (Figure 4). The collection basin has slotted and screened standpipes to allow excess liquid (i.e. urine, water) to seep out of the system for separate treatment. After the larvae development period (2-4 weeks depending upon the temperature and food availability [20, 25]) larvae weight equates to 0.214 kg per pig per day, which would scale to 64,000 kg per year for a 1000-pig house with 2.5 pig cycles per year [22]. The manure volume is reduced by 56% over the course of two weeks, or one larvae cycle [22].

Mature larvae (prepupae) require a dry place for undergoing metamorphosis, thus, once mature they migrate from the manure to a suitable place. This natural migration of larvae can be exploited as a means of automatically harvesting them, as shown in Figure 4 [22]. The harvested prepupae have an average crude protein content of 43% and a lipid content of 28%, which compares to other fish feeds (Table 8) [22].

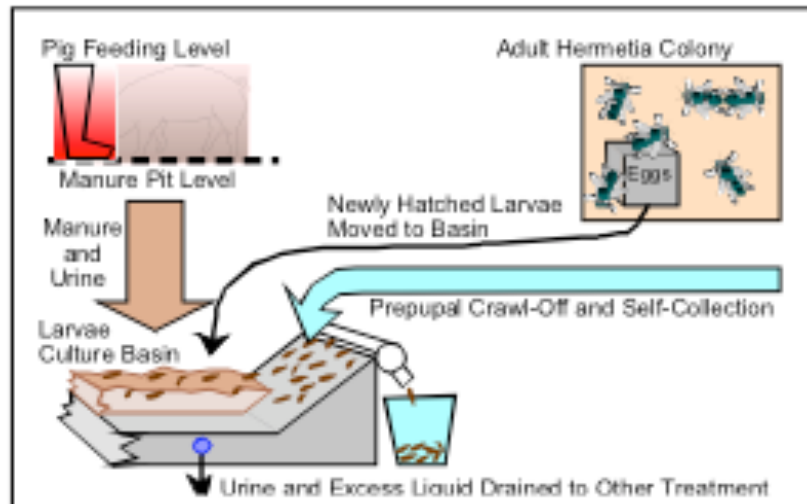

**Figure 4. Schematic of black soldier fly larvae-based swine manure treatment system. Source: Newton 2004.**

**Table 10.** Protein and fat composition of black soldier fly prepupae and larva compared to other fish feeds. Adapted from Diener 2009.

<b>Fish feed</b>	<b>Protein (%)</b>	<b>Crude fat (%)</b>
Black soldier fly prepupae	44	33
Black soldier fly larva	42-45	31-35
Mealworm	48-58	29-38
Fishmeal	62-70	8.9-9.3
Soybean meal	43-47	1.5-1.9

**Box 3. (Cont.)**

**Investment requirements.** BSF-based systems should be inexpensive to construct and maintain [20]. However, representative data are not available, as these systems have not been built at scale in any developing countries.

**Cost recovery.** The global aquaculture industry has been growing rapidly over the last decade, achieving 6.1% growth worldwide and up to 40% in individual countries. Subsequently, the prices of feed are also steadily increasing. As of March 2011, the commodity price of fish meal was USD 1760 per metric ton, up from less than USD 500 per metric ton in 2001 [26]. The most common ingredient in fishmeal and other animal feeds are Menhaden, a small, oily and boney fish that is explicitly caught for this purpose. A study comparing the feed efficiency and weight gain of catfish fingerlings fed on pure Menhaden versus a mix of Menhaden and BSF larvae found no significant difference in uptake efficiency or gain at up to a 25% BSF larvae-substitution rate. Thus, dried BSF larvae should be marketable at comparative prices [27].

**Table 11. Feed efficiency and weight gain among channel catfish fingerlings fed on Menhaden fishmeal and fishmeal substituted with BSF larvae. (Source: Adapted from Newton et al. 2005.)**

	<b>1</b>	<b>2</b>	<b>3</b>	<b>4</b>	<b>5</b>	<b>Control</b>
BSF substitution rate (%)	0	25	50	75	100	NA
Feed/Gain	1.87 <sup>a</sup>	1.96 <sup>a</sup>	2.29 <sup>b</sup>	2.31 <sup>b</sup>	2.55 <sup>c</sup>	2.2 <sup>b</sup>
Gain/Fish(g)	17.96 <sup>a</sup>	17.27 <sup>a</sup>	14.94 <sup>b</sup>	15.94 <sup>a</sup>	13.68 <sup>c</sup>	15.90 <sup>b</sup>

<sup>a,b,c</sup>Different superscripts indicate significant difference (p<0.05).

Digested manure as a soil amendment is another potentially profitable product of the BSF treatment system. The digested manure is free of odors and rich in organic matter that can enhance the soil structure and overall fertility [22]. Data are not available on the level of pathogen reduction that occurs during the BSF digestion process. Therefore, further research is required to determine the public health risks and appropriate protocols for applying digested swine or human feces to agricultural soils. Low-cost on-farm options like those used on FS in Tamale would certainly be applicable (See Box 2).

**Potential for scale.** Considering the wide dispersion of BSFs around the world, and the simplicity and limited costs associated with rearing and harvesting them, this combined FS treatment and profit generating system appears to have great potential for scale. However, BSFs only thrive in warm climates (~27.5°-37.5° C), so this is not a suitable solution for cooler regions. Having a consistent and year-round supply of eggs/larvae has been described as a potential challenge for large-scale systems [22]. Mixing fecal sludge with organic solid waste is likely to yield better overall volume reduction and more protein-rich larvae.

### 3.3 *FS digestion for biogas production*

Biogas recovery is the most mainstream energy endpoint for FS. It is achieved through anaerobic digestion, which is the microbial breakdown of biodegradable matter in FS in the absence of oxygen. Anaerobic digestion is an effective means of stabilizing sludge and simultaneously generating methane, which can be captured and used directly for heating and cooking, converted to electricity, or purified, compressed and bottled for use as a transport fuel.

There are two types of anaerobic digestion commonly used for sludge: mesophilic, which occurs at a temperature of 35° C, and thermophilic, which occurs at a temperature of greater than 55° C. The thermophilic process is more complex and expensive to operate (as it requires an outside heating source), but entails superior pathogen removal, affording safer land application of the remaining solids in agriculture. The average methane (CH<sub>4</sub>) recovery from sludge digestion is 227 m<sup>3</sup> per DT<sup>2</sup>, which equates to about 8800 megajoules (MJ) per DT (about 285 hours of cooking) as heat or cooking fuel, or 980 kWh per DT if converted to electricity [28].

In developing countries, the most common application of biogas digesters is in rural households, where human and animal waste can be combined for digestion, often offsetting the entire cooking fuel demand for a household. By 2008 more than 5 million rural household digesters had been installed in China and India alone [29]. Biogas production and recovery from urban sanitation systems is not as popular because transporting and metering biogas for direct use is difficult and to convert biogas to electricity requires a large-scale system because the conversion efficiency is only about 35%.

The inability to easily store and transport biogas from small- or medium-scale systems is arguably the biggest barrier to operating biogas systems as private business ventures. For systems where biogas flows directly from the point of production to the user, the biogas is usually made available at no cost. In practice it is challenging to privatize and charge for biogas that flows directly from a private producer to an end user. First, an explicit set of users/buyers would need to be identified and the infrastructure – i.e. PVC pipes – put in place to carry the biogas from the digester to the user. Once this happens, the producer becomes “locked in” to a discreet set of customers but is meanwhile left with little recourse if those customers choose not to pay.

Furthermore, having several end users, while reducing the burden of one customer defaulting,

---

<sup>2</sup> Average annual per capita solids production is 15 kg, so every 66 people using septic tanks or latrines produce approximately 1 DT per year.

would require a sophisticated metering system to ensure accurate and transparent pricing based on each customer's biogas usage. Thus, biogas systems that rely on the sale of biogas for revenue will be more viable if the biogas-based product is transportable and sold in discreet quantities that are priced based on their energy content. Selling a transportable and/or value-added biogas product would greatly expand the producer's potential market base and thus the salability of the product.

Technologies are emerging that may improve the viability of biogas storage and transport, thereby strengthening the attractiveness of such small- and medium-scale biogas businesses to the private sector. The simplest means of packaging biogas is to put it in bags for use as a cooking fuel. More sophisticated technologies entail purifying and compressing the gas for use in transportation or distributed power generation (Box 4).

### **Biogas storage bags**

Storage bags (also called balloons) are the simplest and lowest cost technology that allow for easy transport of biogas (Figure 5). Large bags can be used for long-term storage but smaller bags (1-2 m<sup>3</sup>) are amenable to transport and use in households or restaurants for cooking. The balloons are typically made with two layers – an inner bag where the gas is stored and a rugged outer layer that is resistant to tears and UV rays, etc. The bags can have a shelf life of up to ten years.

The biogas is not pressurized and is fed directly into the bags from the digester, or it can first be purified to increase the calorific value.

Several companies in India and China manufacture these bags for export. A 2-m<sup>3</sup> storage bag can be purchased from China for approximately USD 45. One could also consider manufacturing them locally using polythene bags for gas storage with a canvas cover.

The major limitation to this technology is the large size of the bags in comparison to the calorific value of gas they contain. This may be partially addressed by purifying the gas

first (using technologies described below), which increases the methane content from 65 or 70%



**Figure 5. Example of a biogas storage balloon. (Source: Shenzhen Puxin Science and Technology Ltd.)**



to about 95%. Assuming un-enriched biogas is used, the gas has an average calorific value of 26 MJ per m<sup>3</sup> and the average stove burns about 400 L biogas per hour [30]. Thus, a 2-m<sup>3</sup> bag is likely to last for about five hours of cooking. Theoretically, the bags can be connected directly to the stove with a hose, however, there do not appear to be any examples of commercial installations to date. Because biogas must be purified and highly pressurized before bottling, there are not as yet any cost-effective and safe technologies for bottling it as a replacement for propane gas in cooking.

### Biogas purification/enrichment

There are two biogas purification technologies that are commonly used for low-cost biogas applications: water scrubbers and pressure swing adsorption (PSA). Water scrubbers are an effective option for removing CO<sub>2</sub> from biogas, where the basic mechanism entails absorbing of the CO<sub>2</sub> present in biogas into water. The efficiency of the process is dependent on the pressure

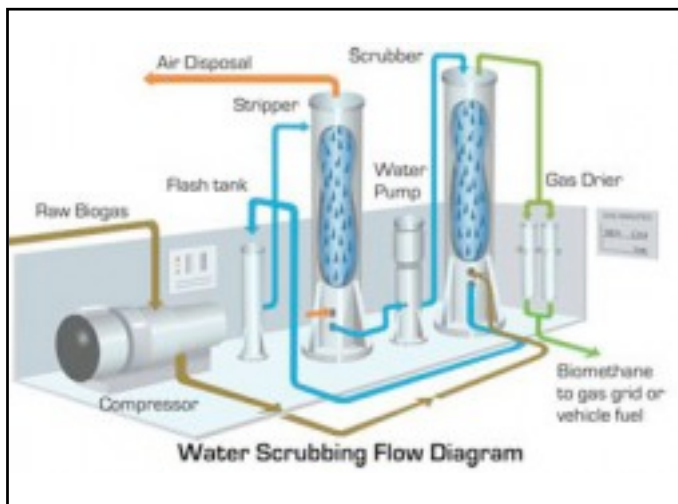

**Figure 6. Schematic of a water scrubbing system for biogas purification. (Source: <http://www.ngvglobal.com>).**

and temperature, where the higher the pressure and lower the temperature, the better the CO<sub>2</sub> absorption.

Researchers have found that a gas pressure of 1 MPa and no active temperature control (i.e. ambient Indian temperatures) allows for the most cost-efficient CO<sub>2</sub> removal [31].

The set-up consists of a column packed with a high surface area media, which allows for adequate contact between the water and gas, a

water supply system, gas supply system, single-stage compressor, a pressure vessel and pipes and fittings (Figure 6) [32]. The biogas enters through the bottom, and is passed under pressure to the top; simultaneously, water is passed under pressure from the top to the bottom of the column. The effluent biogas should achieve a purity of roughly 95% methane. Exposure to the atmosphere is enough to regenerate the water for future use.

Using the second biogas enrichment technology, PSA, the gas is passed over a porous and adsorbent surface (e.g. activated carbon), where the pore size is large enough to trap the CO<sub>2</sub> and H<sub>2</sub>S but too small to trap CH<sub>4</sub> (Figure 6). The gas must be pressurized to 2-3 bars for efficient absorption; typical purity is 97% methane.

The PSA mechanism is one of the most rapidly growing gas separation technologies. One benefit of this process is that it produces a dry gas, which may be necessary depending upon the application. The system is also very consistent and has a small footprint.

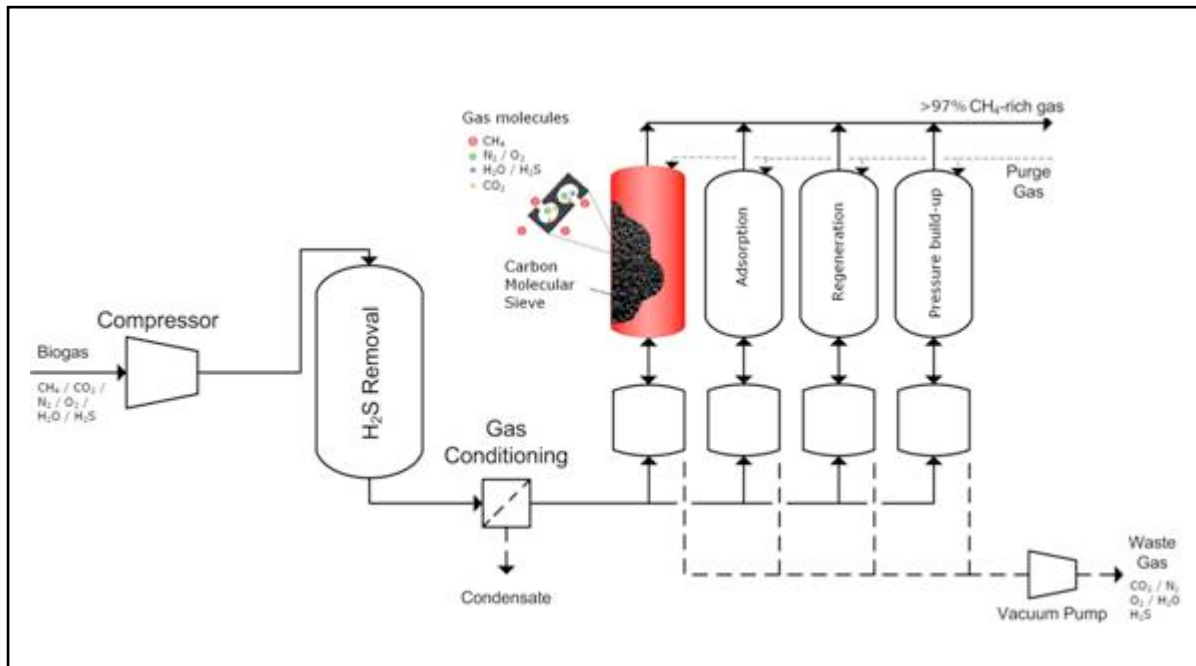

**Figure 7. Example set up of a PSA system, where the adsorption vessels work in alternating cycles of adsorption, regeneration and pressure build up.**  
(Source : [http://students.chem.tue.nl/ifp24/techn\\_psa.htm](http://students.chem.tue.nl/ifp24/techn_psa.htm)).

In general, for small-scale systems (i.e. < 75 m<sup>3</sup> biogas per hour) water scrubbing is the lowest cost option, and for anything larger, PSA becomes more cost-effective.

### Small biogas engine conversion kits

There are technologies that enable the use of biogas in both dual-fuel and exclusively biogas engines, and there are also simple conversion kits available that enable standard diesel and gas engines to run on biogas. In contrast to gaseous fuels that use a spark ignition, diesel engines work on the principle of compression ignition. Thus, the conversion from diesel to biogas entails removing the fuel injection system, incorporating a spark plug, incorporating an air-fuel mixing mechanism, inserting a cam shaft, and adjusting the compression ratio [33]. When a diesel engine is retrofit to run on biogas, the maximum power output of the engine is reduced on average by 50-55%. This is due to differences in the calorific value of the fuels (biogas being only 55-75% methane), and to some extent, due to biogas' slower combustion compared to diesel [33]. Siya

Instruments developed a conversion kit, which they have successfully marketed in India for the past three years. The cost of the conversion kit is Rs 20,000 (~USD 445) and users generating their own biogas recover the cost in 6-9 months through savings on diesel [33]. Most biogas-fueled engines use 0.45 m<sup>3</sup> biogas per horsepower per hour [34].

The uses for diesel engines in developing countries are numerous including electricity generation, water pumping, agricultural processing, and direct mechanical power.

**Box 4. Case study of biogas purification, compression and bottling for use in compressed natural gas (CNG) vehicles in India.**

**Background.** Compressed natural gas (CNG) is used in some countries to replace petroleum and diesel as transportation fuels. Globally, by 2009 there were over 11.3 million CNG vehicles on the road worldwide – these are most heavily concentrated in Pakistan and India, however, they are a global phenomenon [35]. There has been a substantial rise in CNG vehicles across Africa over the last decade, from 25,000 to 1.2 M vehicles between the year 2000 to 2010, with a growth rate over the last year of 18.4% [35]. Technology is now emerging that allows biogas to be used as a substitute for CNG.

**Reuse practice.** Since 1981, the Ministry of New and Renewable Energy in India has supported research, development, and pilot projects on all aspects of biogas production and applications. Some of their initiatives include: the National Biogas and Manure Management Program; the Biogas Based Distributed/Grid Power Generation Program; Recovery of Energy from Industrial Waste; Recovery of Energy from Urban Wastes; Establishment of Business Models for Integrated Technology Packages; and Demonstration of Integrated Biogas Fertilizer Plants and Purification/Enrichment, Bottling and Pipe Distribution of Biogas.

As part of the latter research initiative, the Centre for Rural Development and Technology at the Indian Institute of Technology, New Delhi (CRDT at IIT-Delhi) has developed a low-cost system to compress biogas for use in CNG vehicles. The basic concept is to purify and compress the biogas under high-pressure conditions – 200 bar (20 Mpa) – and to store it in steel cylinders specifically designed for high-pressure gas storage. The unit comprises a three-stage compressor, ultra filters, storage cylinders, pipe fittings and accessories, and basic instrumentation [32].

**Investment requirements.** The biogas enrichment (i.e. water scrubber) and compressing unit costs approximately Rs 6 M (~USD 133,000) for a 1000 m<sup>3</sup> per day system [32].

**Cost-recovery potential.** To promote the adoption of various biogas technologies and to create a market that can be tapped by biogas entrepreneurs, the Ministry of New and Renewable Energy offers attractive subsidies. For example, they provide up to 40% of the capital cost of biogas-based power generation plants. The Centre for Rural Development and Technology (CRDT) at the Indian Institute of Technology-Delhi is one of the Ministry's main research partners and is perhaps the leader in the development of low-cost and effective technologies for purifying, compressing and bottling biogas (Indian Institute of Technology Delhi 2008).

Based on the Centre's research, the systems are cost-effective (in India) at a production capacity of >400 m<sup>3</sup> biogas per day. Cost-effectiveness will be contingent on the local cost of CNG and on the costs of operating the facility, which will vary based on local costs of labor and utilities.

**Potential for scale.** This technology has yet to be proven on a commercial scale. While the technology itself may work, a viable business model for producing and selling the CNG substitute at a profit, has yet to be developed and vetted. Furthermore, the transferability and scalability of the model will be contingent on the presence of CNG vehicles in the region or country of interest. Overall, this is a technology that appears to have vast potential for improving the usability of biogas, however, further research is necessary, particularly on the business side.

### 3.4 *FS as an industrial fuel*

The use of sewage sludge<sup>3</sup> as an industrial fuel is a recent trend, largely driven by increasing oil costs, concern about climate change, and pressure to find volume-reducing sludge management options. In particular, co-incineration of sludge as a fuel for cement kilns is increasingly common across the US, Europe, and Asia, accounting for about 2% of alternative fuel substitution in cement production [36]. China, with an annual sludge production of over 30 million tons, is rapidly embracing the win-win sludge disposal and energy production solution. In Guangdong, China for example, the Guangzhou Heidelberg Yuexiu Cement Plant burns 600 tons sewage sludge per day (Box 5).

The lower heating value (LHV) (i.e. the heat of combustion) of sewage sludge typically ranges from 10-29 GJ per DT, compared to an average coal LHV of 26 GJ per ton [37]. The LHV is proportional to the organic content, and to the degree of stabilization that has already taken place (e.g. aerobic and anaerobic digestion), as stabilization decreases the volatile content (metric of combustible organic content) of the sludge. Sludge used for fuel is usually taken from the activated sludge or anaerobic digestion stage of municipal wastewater treatment facilities, where a significant amount of the organic carbon has been digested. For example, the heating value of sludge from primary treatment (25 MJ per kg of total solids) is halved following anaerobic digestion (12 MJ per kg of total solids).

The LHV of sludge is measured based on its dry solids content. Thus, the water content accompanying the solids is another key determinant of the amount of energy that can be harnessed from sludge when burned in an industrial furnace or kiln. Sludge does not need to be completely dried prior to incineration; cement kilns are technically able to incinerate sludge with a dry solids content as low as 20% (moisture content of 80%) [38]. However, to recover net energy from the sludge, a dry solids content of greater than 20% may be needed. Based on research conducted in China on biosolids with a LHV of 15 GJ per DT, a cement plant would realize a net energy benefit if the dry solids content were  $\geq 36\%$  [37]. Table 12 shows a comparative example of the necessary energy inputs and potential outputs if burning 1 wet ton of sludge with equivalent LHV but varying water contents.

---

<sup>3</sup> A byproduct of conventional wastewater treatment plants comprising the solids from primary settling tanks and the sludge extracted from activated sludge systems.

**Table 12. Comparative analysis of the energy gain or deficit for a cement kiln burning 1 (wet) ton sewage sludge at 25% and 90% dry solids.**

Sludge Characteristics	Water Heating Energy (KJ)	Vaporization Energy (KJ)	Steam Heating Energy (KJ)	Total Energy Req. (MJ) (75% kiln efficiency)	Energy Content of DS (MJ)	Deficit/Gain (MJ/ton sludge)	Fuel Cost/Savings <sup>b</sup> (USD/ton)
25% dry solids; 10.5 MJ/kg dry solids (LHV <sup>a</sup> )	263,340	1,695,000	1,636,335	4793	2625	<b>-2168</b>	<b>8.68</b>
90% dry solids; 10.5 MJ/kg dry solids (LHV)	35,112	226,000	218,178	639	9450	<b>8811</b>	<b>-36.3</b>

<sup>a</sup>The energy content reported is in terms of the lower heating value (LHV) and is defined as the net calorific value, as it assumes that the latent heat of vaporization of water in the material is not recovered. <sup>b</sup>Value assumes coal cost is USD 107/ton (Kenyan price as of December 2010).

Of course, the dryer the sludge when it reaches an industrial plant, the higher the upfront cost of drying it. The financially and environmentally optimal level of drying will vary based on a number of factors like the dry-solids energy content of the sludge, the transportation distance between the point of origin for fecal sludge and the receiving industry, land availability and climate suitability for open-air solar drying, among others variables. A number of technologies exist for drying the sludge, from the lowest-tech option of open-air drying beds, to electric belt filter presses, to electric centrifuges, to heat dryers, which are usually fired with fossil fuels, waste-heat, or natural gas [39-44]. While drying beds have the lowest capital and operating costs, they have the largest footprint, which can make them unattractive for urban areas where open land is in scarce supply. Drying beds are also unsuitable for cold and/or wet climates. Different drying technologies can also be compared based on their drying capacity. Belt filter presses typically achieve about 20% dry solids [39], in tropical climates, drying beds achieve about 70% dry solids after a two-week retention time [43], and heat dryers can render the sludge almost completely dry – over 90% dry solids – with enough energy input.

### **Box 5. Case study of co-incinerating sewage sludge in a Chinese cement kiln.**

**Reuse practice.** Chongqing is located on the banks of the Yangtze River in southern China, and is one of the world's largest cities with a population of 34 million people. Chongqing's wastewater treatment plants generate more than 100 dry tons of sewage sludge per day, which in the past they landfilled. However, between the ever-increasing volumes of sludge being generated and a National-level Chinese policy that limits the amount of sludge that can be landfilled, Chongqing's Environmental Protection Bureau spearheaded an innovative solution that is both economically efficient and good for the environment.

In March 2007, Chongqing's government-run wastewater treatment plant began a partnership with the French-owned cement company, Lafarge Shui On. Today, the wastewater treatment plant delivers 100 tons of sludge per day to the cement kiln for burning and incorporation into the cement. In the 1990s, Lafarge was the first cement company to experiment with using sewage sludge in cement. Now they and other companies accept sludge at several kilns around the world, particularly in Japan and South Korea.

In practice, dewatered sewage sludge is injected into the kiln and the noncombustible material is incorporated into the clinker, a precursor to Portland cement. This means 100% of the material is used, making it a closed-loop management option.

Cement kilns are able to accept sludge with a dry solids content as low as 20% but assuming an average calorific value, sludge typically needs to be approximately 35% dry solids for a cement plant to recover net energy from it.

**Investment requirements.** The capital investment was USD 815,000 for sludge transport vehicles and a fully automated sludge injection and digital monitoring system. Certainly, there are lower cost alternatives to this state-of-the-art injection and monitoring system. For a cement plant to accept wet sludge (i.e., less than 90% dry solids), the following equipment is necessary: buffer storage hopper (usually 100m<sup>3</sup>); screw conveyor for moving sludge; piston pump (150 barr pressure); and sludge injector. On the other hand, if sludge is delivered dry, the equipment needs are far fewer and the investment cost for the cement plant decreases by approximately 50%.

**Cost recovery.** Cost recovery depends on the dry solids content and calorific value of the sludge, and on transportation costs.

**Risks.** End use of sludge in cement effectively immobilizes any heavy metals found in sludge (with the exception of highly volatile varieties, such as Hg), and prevents unwanted human contact with sludge, which may arise from indiscriminate dumping. Heavy metals may be found in some household products that make their way into wastewater but they should not present a real problem unless industrial wastewater is mixed with domestic sources.

**Potential for scale.** Based on experiences using conventional sewage sludge as fuel, the potential for transferring this management solution to use fecal sludge appears promising. Research and development on average fecal sludge calorific value, low-cost sludge drying options, and on necessary technical retrofits to receiving boilers is required, as are pilot demonstrations prior to large-scale implementation (See Box 6).

To date, FS has not been tested or utilized as an industrial fuel. However, given the factors that determine the LHV of sewage sludge, FS sourced from pit latrines or septic tanks with relatively short retention times (thus, undergoing comparatively less stabilization than sewage sludge) is likely to contain a similar or higher calorific value compared to primary and activated sewage sludges.

Regarding water content, in its raw form FS can have a solids content as high as 20%. In tropical climates, open air, sun drying beds can achieve up to 70% dry solids after only 10 days [43]. With demand for energy on the rise in developing countries, industrial sectors ever-growing, and growing interest in renewable energies, the use of FS as an industrial fuel appears to be an application that will remain in demand and highly relevant for the foreseeable future.

#### **Box 6. Research Project to Watch: Fecal sludge-to-industrial fuel.**

Faecal Management Enterprises (FaME) is a research project funded by the European Water Initiative ERA-NET – SPLASH, and launched in March 2011. The project team comprises six institutions: Eawag/Sandec in Switzerland, Waste Enterprisers Ltd. in Ghana, Cheikh Anta Diop Dakar University in Senegal, the National Sanitation Utility of Senegal, Makerere University in Uganda, and Hydrophil in Austria.

Among other research activities, the FaME team will assess the technical and financial viability of using FS as an industrial fuel, characterizing the calorific value of FS (among other parameters) and the industrial sectors in three cities: Dakar, Senegal, Kumasi, Ghana and Kampala, Uganda. The results will be used to assess the financial and technical viability of using FS as fuel, to determine optimal FS pre-drying under different scenarios, and to develop potential business models. The research will culminate with a demonstration project of using partially dried FS as fuel at a cement plant in Dakar.

Preliminary results on the characteristics and fuel potential of FS are expected in early 2012, and the demonstration project should be implemented by mid-2012. See the project website for further details and updates: <http://www.sandec.ch/fame>.

#### *3.5 FS to charcoal (household cooking, industry)*

Hydrothermal carbonization (HTC) is an old discovery that was largely ignored until the last few years. It is now recognized in climate-change-mitigation spheres as a promising tool for creating carbon sinks: the carbon in biomass is captured as “biochar”, which is then applied to soils for storage [45, 46]. Sometimes called wet pyrolysis, HTC is a simple method: heat wet biomass with a weak acid in a closed pot at 200° C for 4-24 hours [47]. Ultimately, one is left with solid carbon char and filtrate. The process is fast, eliminates the need for costly drying processes – because of the inherent need for water (70 to >90%), and the final carbon product is easily filtered. Furthermore, the calorific value is maintained and concentrated, as HTC produces very



little loss of carbon as CO<sub>2</sub> [47]. Thus, (carbon-neutral) fuel is another interesting application worth exploring for the char.

HTC makes it possible to convert biomass feedstocks that are too wet for other carbonization processes (e.g. human waste, municipal solid waste, animal manures, and algal residues) into carbonaceous solids. The solids can then be used for soil enrichment or thermal purposes [46]. Characteristics of the sludge feedstock, such as water content, volatile solids content, non-combustible content and particle size would, however, influence the efficiency with which biomass is converted. Additionally, subjecting human waste to HTC would also eliminate all pathogens given the HTC processing time and temperature [46].

The revival of HTC has yet to be applied to fecal sludge, though it appears to be a promising management option for both community and municipal scale sludge management. Depending on local market demand, the char could then be sold as a fuel (e.g. replacing charcoal in cookstoves or industrial boilers) or as a soil enhancement in agriculture. To date, there are no experimental results available for using HTC on sewage sludge or other forms of human waste and the financial aspects are also weakly understood [46]. Based on results from other wet feedstocks, waste-heat recovery would likely be essential to make the process cost-effective. Other operating expenses that require further understanding include post-processing to separate the solids and liquid, and treatment of the liquid stream [46].

**Box 7. Research to Watch: Fecal sludge-to-briquettes.**

Researchers in Kampala, Uganda hypothesize that HTC would be well suited for converting fecal sludge from on-site sanitation systems into household cooking fuel. They propose piloting the technology in high-density slum areas to simultaneously tackle the challenges of inadequate waste management and difficultly accessing affordable fuel among the urban poor.

A research team is currently seeking funding to test and optimize the HTC technology for fecal sludge and to test the marketability of the char among various user groups.

*3.6 FS as a feedstock for biodiesel*

Conventional sewage sludge is emerging as a popular and viable feedstock for biodiesel production across the US and Europe. Biodiesel is an increasingly attractive renewable fuel because it is a near perfect substitute for petroleum diesel. However, while the basic technology for producing biodiesel (using oils from cultivated crops) is well developed, large-scale production and distribution is hindered by the costs of production compared to petrol-diesel. The

biggest cost of production is usually the feedstock, which can account for 40-80% of the total cost [48, 49]. Thus, researchers have begun experimenting with sewage sludge as a feedstock – indeed, a material that readily exists and that has traditionally been an expensive management problem.

Pure biodiesel can be utilized in any diesel engine without modifications to the engine. However, biodiesel substitutes must achieve a certain quality as specified by the American Society for Testing and Materials biodiesel standard, ASTM D6751. Thus, it is more common to mix biodiesel with petrol-diesel at a ratio of 20:80, thus lowering the quality standard.

Fuel consumption is slightly higher for biodiesel than petro-diesel but biodiesel has several benefits including a higher flash point, lower sulfur content, particulate and aromatic contents, better biodegradability, and it is renewable [50]. Furthermore, given that the feedstock for the biodiesel would be fecal sludge, which is defined by the Inter-governmental Panel on Climate Change (IPCC) as “carbon neutral”, the biodiesel itself (with the exception of any fossil inputs required in the production process) would also be carbon neutral.

The chemistry of biodiesel production entails converting the lipid and/or other organic content of a feedstock into fatty acids alkyl (methyl) esters (FAMES). The production of FAMES from sewage sludge or fecal sludge can be approached in two ways. One option is to convert the lipid fraction of the sludge (comprising triglycerides, diglycerides, monoglycerides, phospholipids and free fatty acids) into FAMES via base- or acid-catalyzed transesterification<sup>4</sup> (Figure 7). The second option is to convert the more complex organics into additional fatty acids and subsequently convert the fatty acids thus derived into FAMES via acid-catalyzed esterification<sup>5</sup> (Figure 8). Yields from sewage sludge typically range from about 2.5 to 14 wt % for secondary and primary sludge [49, 51, 52]. Thus, assuming that FS collected from various public toilet blocks and private septic tanks exhibits characteristics that are akin to primary sewage sludge, one could conservatively expect an average biodiesel yield of 1 kg per 10 kg of FS.

---

<sup>4</sup> Defined as the conversion of one ester into a different ester.

<sup>5</sup> Defined as the combination of two reactants, usually a carboxylic acid and alcohol, to form an ester

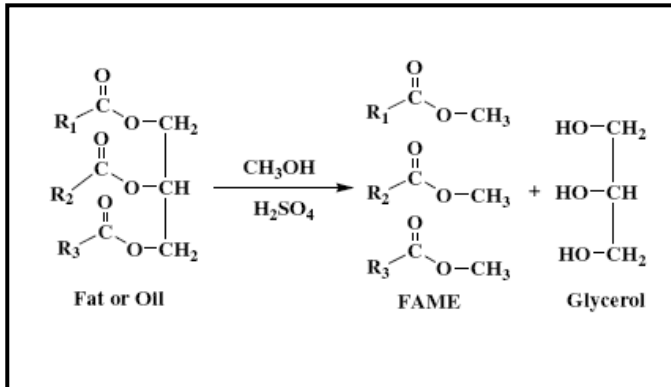

Figure 8. Acid-catalyzed transesterification of lipids to FAME and glycerol (Reproduced from Mondala 2009).

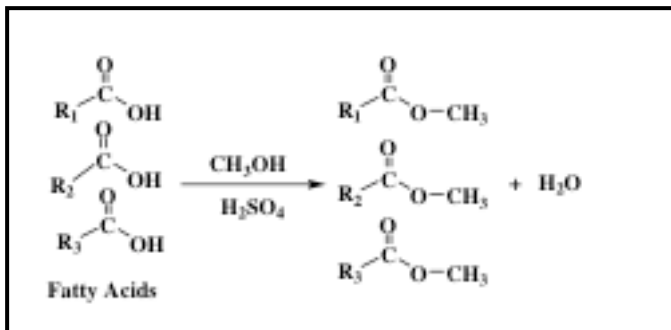

Figure 9. Acid-catalyzed esterification of fatty acids to FAME and water (Reproduced from Mondala et al. 2009).

As shown in Figure 7 and 8, CH<sub>3</sub>OH (methanol) is a necessary input into the production of biodiesel. Thus, this and the strong acid or base would need to be purchased as inputs.

**Box 8. Research Project to Watch: Fecal sludge-to-biodiesel.**

The Earth and Environmental Engineering Department at Columbia University, Waste Enterprisers Ltd., and the Chemical Engineering Department at Kwame Nkrumah University of Science and Technology in Ghana are launching a research project to develop a technology for producing biodiesel from FS. The project, which is based in Accra, Ghana, is supported by the Bill & Melinda Gates Foundation and will run from June 2011- June 2013.

The team's goal is to develop the technology and an accompanying social enterprise model that channels the revenues from biodiesel to explicitly benefit those who cannot afford safe sanitation emptying and treatment services.

The pilot plant's technology train will include fermentation and anaerobic digestion stages, therefore producing both biodiesel and biogas.

**Foreseeable challenges.** The production of biodiesel from sewage sludge is still a nascent technology; thus, there is still much to be learned about optimizing operating parameters and yields. As fecal sludge has never been used as a feedstock, its unique characteristics compared to sewage sludge may present unanticipated challenges or barriers.

## 4. WASTEWATER USE: SUMMARIES AND CASE STUDIES

### 4.1 *Wastewater-fed aquaculture*

The use of wastewater for aquaculture is a common practice around the world, particularly in Asian countries where its history dates back centuries [53]. The practice is driven by a scarcity of nutrients (or resources to purchase them,) water scarcity, and a desire to protect receiving water bodies [54]. The city of Calcutta in India began using its wastewater to fertilize fish ponds in the 1930s, and the city's system is now considered the largest wastewater-fed aquaculture scheme in the world [55].

Aquaculture as a practice has been growing rapidly for several years, and it is predicted that farmed fish will soon be the dominant source of animal protein in developing countries [56]. Thus, end use of wastewater in fish and aquatic plant ponds promises to be a solution with long-term application, and one that simultaneously serves as a means of pollution control, and of recovering the nutrient value in wastewater for fish and/or plant growth. The nutrients in wastewater effluent stimulate the growth of plankton, which the farmed fish feed on, and aquatic plants will take up the nutrients directly [57]. Well operated waste-fed fish ponds, including examples in Calcutta, Hanoi and Lima, consistently yield 3-8 tons fish per hectare per year without supplementary feed [57].

For the vitality of the fish and to mitigate potential human health risks associated with consuming the fish or plants reared in waste-fed ponds, raw wastewater should be treated to reduce BOD, ammonia, and pathogen levels prior to its release into fishponds. Specific water quality requirements are dependent on the fish species, local climate, and pond design, but guidelines based on the current state of knowledge are shown in

Table 13 [55, 57]. The WHO recommends an *E. coli* count of  $<10^4/100$  mL in the influent water to an aquaculture pond to protect aquaculture workers and consumers [54]. Other researchers have suggested that total bacteria should be used instead of *E. coli* because the latter can be an unreliable indicator organism in fish tissue [57]. Pre-treatment of the wastewater is also important for reducing the initial nitrogen concentration; a recent study suggests that fish which are exposed to excessive levels of ammonia and nitrates are more susceptible to bacterial infections, which can increase fish mortality [53, 57].

Typical wastewater pre-treatment schemes consist of a series of anaerobic and facultative ponds prior to discharge into the fish ponds [55]. The fish ponds also play a role in the wastewater treatment process, as studies in the Calcutta ponds show a reduction in both nutrients and pathogens between the inlet and outlet of the fish ponds [54, 55, 58]. In fact, the negative environmental impacts that are often associated with aquaculture are linked to freshwater systems that are overloaded for high input and output, not the dual purpose sanitation and aquaculture facilities [54].

It is critical that wastewater-fed aquaculture ponds are stocked with fish species that are suited to the prevailing water and environmental conditions. In particular, the fish must be able to withstand low oxygen conditions. Some of the most suitable species for waste-fed ponds include several varieties of carp, catfish, largemouth bass, freshwater prawn and tilapia [55]. The latter are particularly tolerant of low oxygen levels and a wide range of pH and salinities [55]. Numerous types of aquatic plants can be grown in waste-fed ponds including water chestnuts, water spinach and watercress [54]. The recent WHO guidelines for reuse of wastewater in aquaculture provide a lengthy list of fish and plants that are commonly grown in such ponds [54]. The fish do not require additional nutrition nor is aeration necessary [55].

Heavy metal accumulation in the flesh of fish raised in waste-fed ponds in comparison to freshwater ponds has been studied, and in general, there is not a significant difference between

the two [54]. While it is true that metals can bioaccumulate in fish tissues, the metals in wastewater tend to precipitate out as insoluble sulfides or hydrated oxides [54]. Mercury is an exception to this rule and can only be prevented from bioaccumulating by controlling its concentration in the influent [54].

**Table 13. Water quality standards for wastewater-fed aquaculture.** (Source: adapted from UNEP-IETC 2002).

<b>parameter</b>	<b>standard</b>
BOD (kg/ha/d)	10-30
total N (kg/ha/d)	4
NH <sub>3</sub> (un-ionized ammonia) (mg/L)	0.5
total P (kg/ha/d)	1
nighttime DO (mg/L)	≥2-3
total bacteria <sup>a</sup> in water (SPC/mL)	≤10 <sup>5</sup>
total bacteria in fish muscle (SPC/g muscle)	<50
Salmonella (SPC/g muscle)	none detectable

<sup>a</sup>Total bacteria refers to standard plate count (SPC), and not to fecal total coliform. E. coli has been determined to be an unreliable indicator for the quality of fish grown in waste-fed ponds [57].

To date, most wastewater-fed aquaculture is practiced informally and without any direct tie to the wastewater treatment plant supplying the water. The case study presented in Box 9 presents an innovative business model for linking wastewater-fed aquaculture to existing waste stabilization ponds in order to improve the daily performance of those ponds.

### Box 9. Case study of wastewater-fed aquaculture in Ghana: the Waste Enterprisers model.

**Reuse practice.** Waste Enterprisers, a private company registered in Ghana, is currently piloting a novel aquaculture business model that aims to improve the on-going operation and maintenance of waste stabilization ponds (WSP) while at the same time generating profit.

The Ahinsan Estate WSP system in Kumasi, Ghana is a community-scale facility comprising four ponds and serving less than one thousand people. Household wastewater enters the first pond and moves through the series of four, which are engineered for particular biochemical and physical treatment processes. In a well-designed and performing system the effluent quality should meet environmental discharge guidelines.

In 2010, after preliminary water quality analyses, Waste Enterprisers forged a contract with the Kumasi Metropolitan Assembly that gives the company access to the government-run WSP and permission to raise catfish for commercial sale in the final (maturation) ponds of the system. In exchange for access to ready-made ponds and nutrient-rich water, Waste Enterprisers has taken responsibility for the daily operation and maintenance of the community-scale treatment plant.

The logic is simple. Prior to Waste Enterprisers' arrival, on-going maintenance of the system was largely neglected. Indeed, without user fees and/or rigorous enforcement of environmental regulations in Ghana, the Kumasi Municipal Assembly lacked the financial resources or incentives to adequately maintain the treatment system. Now Waste Enterprisers depends on the adequate performance of the treatment plant for the health and safety of their fish, workers, and consumers. Thus, the company has every incentive to employ a full-time groundskeeper and to ensure on-going maintenance and monitoring of the system. With a strong financial incentive to maintain the WSP, Waste Enterprisers' presence has been a winning proposition for the government.

**Investment requirements.** With the elimination of land acquisition and pond construction, the start-up costs of aquaculture drop dramatically. Capital investment is limited to some key fish-farming supplies. On-going costs include fingerlings (one batch approximately every six months), water quality and fish quality monitoring, and a full-time groundskeeper/guard (Table 11).

**Table 14. Capital and on-going costs associated with the Ahinsan Estate wastewater-fed aquaculture business.**

	<b>Unit cost (USD)</b>	<b>Total cost (USD)</b>
	<i>start-up costs</i>	
Aquaculture equipment (dragnet, scale, buckets, boots)	500	500
	<i>direct operating costs</i>	
catfish fingerlings	0.17/fingerling	204
groundskeeper	69/month	413
water/fish monitoring	50/sampling campaign	300
<b>TOTAL direct costs</b>		<b>917</b>

**Cost recovery.** Revenue for Waste Enterprisers comes from the sale of catfish, which are harvested every six months when they weigh an average of 1 kg each. A successful aquaculture operation should have a survival rate of at least 70%. Waste Enterprisers has been struggling to achieve this level due, they believe, to low dissolved oxygen in the maturation/fish ponds. Waste Enterprisers attributes the unusually low oxygen levels to overdue desludging of all of the ponds.

They are negotiating with the Kumasi Metropolitan Assembly to have the ponds desludged before the next cultivation period, at which point they aim for the returns presented in Table 12.

**Table 15. Potential revenue generated per six-month catfish cultivation at the Ahinsan Estate wastewater-fed aquaculture system.**

	Unit price (USD)	Total return (USD)
Catfish sales (assuming 1 kg at harvest and 70% survival)	2.5	2100
Net revenue (excluding capital costs)		1183

**Occupational risks.** Since the aquaculture occurs at a wastewater treatment plant, there are fecal pathogens present in all of the ponds, including the maturation ponds where the fish are being cultivated. Employees do come into contact with these pathogens during fish sampling campaigns when they enter the maturation ponds to pull the dragnet through the water. Fish harvesting is another time when employees come into contact with pathogens, as the fish do have them on their surface. Employees wash thoroughly upon completion.

The final occupational hazard is in the processing of fish prior to sale to consumers. In Ghana, catfish are usually smoked before being sold on the market. Thus, the smoker should be made aware of the source of the fish such that they wash thoroughly after handling.

**Consumer risks.** Assuming the fish are thoroughly smoked prior to being sold on the market, there should be no fecal pathogens from the maturation ponds present in or on the fish when they reach consumers. However, there are other constituents that if in the wastewater can accumulate in the fish and pose a threat to humans.

Prior to stocking the fish, the wastewater should be tested for heavy metals, like cadmium, mercury and lead as well as for pathogens. The World Health Organization (WHO) has a set of recommended guidelines for both pathogen and heavy metal levels in wastewater-fed aquaculture systems [59].

**Potential for scale.** Where there are waste stabilization ponds there is potentially an opportunity for wastewater-fed aquaculture. Waste stabilization ponds are the most common type of low-cost natural treatment system around the world. Though their on-going maintenance requirements are relatively simple and inexpensive (i.e. clearing grit chambers, clearing vegetation pond surfaces and perimeters) it is nonetheless common for their performance to suffer from neglect, particularly in developing countries. In Africa, WSPs are in relatively widespread use in Ghana, Tanzania, and Malawi, and they are quite abundant in Kenya, Morocco and Egypt among other countries.

The quality of the influent water is the biggest determinant of the safety and feasibility of raising fish in the maturation ponds. From the standpoint of fish health and survival, adequate dissolved oxygen levels and low enough ammonia-nitrogen are absolutely critical. And from a public health perspective, heavy metal concentrations should be below the safety threshold recommended by the WHO.



#### 4.2 *Wastewater-fed irrigation*

Today in California, 67% of wastewater is reclaimed for agricultural and landscape irrigation, and in Middle Eastern countries 70% of irrigation water is sourced from wastewater [60, 61]. On a global scale, there is still great opportunity for increasing reuse in agriculture as wastewater-fed irrigation only accounts for 1% of water demand by the agricultural sector [62]. There are numerous drivers of reuse for irrigation including water scarcity, protection of surface water ecosystems, increased demand for food, and recognition of the resource value of wastewater [61]. In developing countries, direct reuse of untreated wastewater often occurs; while this practice is an important source of livelihoods for local farmers and contributes to food security, it has been linked to public and environmental health threats [60, 61]. On the other hand, the use of treated wastewater for irrigation is widely recognized as a safe and beneficial practice as long as the potential human health and environmental risks are managed [63-65].

Studies show that crops irrigated with wastewater have yields 20-50% higher than the same crops grown with freshwater supplemented with commercial fertilizer [61, 63, 66-68]. The difference is partially explained by the nutrients present in the wastewater and the fact that they are in a form that is readily assimilated by plants [68]. Plants generally take up nitrogen in the form of nitrates, which is the state that most other wastewater nitrogen is converted to in the soil [61]. Domestic wastewater has a high nutrient content due to daily human excretion on the order of 10-12 g nitrogen, 2 g phosphorus, and 3 g potassium per person [69]. In theory, wastewater can be used to offset application of chemical fertilizers (particularly nitrogenous), though in practice, most farmers do not change their fertilization habits because they are unaware of the nutrient value of the water [70, 71]. The organic matter in wastewater also improves yields and crop characteristics by enhancing the soil's fertility and microbial activity [61, 63, 72].

Having frequent and reliable access to wastewater flow can dramatically improve farmers' livelihoods. Wastewater can provide a year-round source of irrigation water, and thus the opportunity to increase the number of crop cycles per annum [60, 70, 73]. Other indirect social benefits also emerge from wastewater irrigation including increased earning opportunities for local laborers, goods transporters, and vendors [60].

Wastewater reuse for irrigation can also be used to avoid the costs of treating wastewater to a level that would otherwise be required to meet the standards for discharge into surface waters. For example, the province of Mendoza in Argentina has moved away from blanket effluent

standards to ones that are end-use-specific; agricultural reuse standards are often less stringent and costly than those for environmental discharge, so reuse is a way to free up resources to provide improved sanitation to a much larger fraction of the population [74]. A cost-benefit analysis of wastewater reuse for irrigation in Sweden also determined substantial savings in the capital and operation costs of treatment infrastructure by incorporating reuse and eliminating the nutrient removal process that would be necessary to discharge to local rivers [75].

Related to wastewater treatment costs, the International Water Management Institute (IWMI) in Ghana is carrying out a unique pilot-study to look at the potential for channeling a portion of profits earned through wastewater-irrigated agriculture to help pay for the operation and maintenance costs of the treatment plant (Box 10).

**Box 10. Research Project to Watch: Paying for wastewater treatment with wastewater irrigation.**

The International Water Management Institute in Ghana, in collaboration with the Water Resources Commission (Ghana), is launching a novel action-research project test a market- and reuse-oriented approach to sanitation called Design for Service. With support from the African Water Facility, the goal is to demonstrate that effectively capturing and allocating the resource value of wastewater, FS, and treatment byproducts can serve to finance and incentivize robust sanitation systems.

One of the project modules entails using wastewater irrigation to help pay for the operating costs of the treatment plant supplying the wastewater. To test the model, the project includes rehabilitating a wastewater treatment plant at the Presbyterian Boys Secondary School in Accra, and installing conveyance and storage infrastructure for effluent reuse in irrigation. The effluent will be sent to an adjacent field that has historically been used for rain-fed agriculture. The concept is to cultivate the land for high-value agriculture and to channel a portion of profits from the agriculture to help cover the operating costs of the treatment plant.

Prior to rehabilitating the treatment plant, researchers will conduct a detailed financial analysis to estimate the potential agricultural yields and market value of crops grown with the wastewater effluent. The expected financial returns from agriculture will inform decisions about the wastewater treatment technology, such that the greatest fraction of operating costs can be met through agricultural revenues, while meeting public health requirements.

Researchers will monitor the treatment plant-cum-agriculture model for several years once in operation to test the viability of the concept in practice.

Of course, wastewater irrigation does carry certain risks to both human and environmental health. Certainly, the risks are exacerbated when raw sewerage is used. Like with wastewater-fed aquaculture, the WHO has set guidelines for the minimum water quality standards for wastewater

irrigation to avoid undue risk to farmers or consumers. Their guidelines equate to a tolerable burden of waterborne disease of  $\leq 10^{-6}$  disability adjusted life years (DALYs) per person per year [61]. As the local economy and institutional capacity permits, some regions have set higher standards to further reduce the public health risk.

## **5. CONCLUSION**

As indicated by the breadth of reuse options and case studies presented in this chapter, the scope for reusing human waste is vast and full of untapped potential. Technologies for reuse are still being developed and improved upon. But mainstreaming reuse as a waste management approach most urgently requires further investment in developing the accompanying business models, raising awareness among entrepreneurs and investors about these business opportunities, and demonstrating their profitability through pilot implementations. The following chapter outlines waste-based business opportunities that appear most promising for the Nairobi, Kenya region.

## **4. Prospects for Reuse in Nairobi, Kenya**

---

There is a striking amount of innovative waste reuse already happening in and around Nairobi. More than 2000 people in the city make their daily living through resource recovery from solid waste, diverting about 7% of the waste stream from landfills [76]. Among the waste diverted, an estimated 11 community-based organizations in Nairobi collect organic waste to produce compost for income generation [77]. Another example of reuse is using animal waste and agricultural byproducts (including cow dung and poultry manure) for biogas production and/or fertilizer. From farms to slaughterhouses, a number of systems large enough to produce electricity exist around Nairobi. The Ministry of Energy is currently working on weaning large horticulture farms – massive consumers of electricity due to overnight lighting – off the grid by using biogas digesters that would be fed with the waste components of the farms' flowers [78].

Yet another innovative endpoint for so-called waste is briquettes. The Kayole Environmental Management Association (KEMA), Mazingira Institute and Chardust Ltd. are just a few of the local organizations and companies that are turning various solid waste streams into carbon-neutral fuels for cooking or industry. KEMA also collects discarded plastic bags and turns them into sophisticated handbags and heavy-duty fence posts.

In spite of the pervasive culture of reuse in Nairobi, there is also a culture of stigma against using human waste. Thus, there are currently very few examples of human waste reuse to be found. Kenya is not at all unique in this sense; social acceptance of reuse is often a major stumbling block in the sanitation sector. However, studies have shown that the more removed a reuse option is from human contact the greater the public acceptance [79]. Education and sensitization are also ways to successfully build acceptance around reuse [30].

The prevailing stigma against reusing human waste should be recognized but not taken as a deterrent to developing a human-waste-based business sector in Nairobi. Indeed, awareness of the likely concerns of target consumers and preparedness to address and quell those concerns will make or break the success of the business endeavor. A firsthand experience by Umande Trust is an illustrative example. Umande Trust is a community organization working in several slums in Nairobi, and among other projects they have been building Bio Centers – biogas-equipped public toilet blocks. In their initial design, Umande built a toilet block with an attached kitchen that had several burners all fueled by biogas generated from the toilet waste. The kitchen was open to

anyone who wanted to use it. No one did. Umande subsequently embarked on promotional campaigns and also learned to separate the biogas-powered kitchen from the toilet block in future designs. Now the burners are well used.

Thus, with a “can-do” attitude, there are many promising opportunities for human-waste-based businesses in Kenya. The following section presents a set of what appear to be “best bet” waste-based business opportunities to explore in Nairobi and/or Kenya. The best bets are presented in the format of a business feasibility study, presenting what is known and still needs to be understood from the following categories:

8. Market Viability;
9. Technical Viability;
10. Business Model Viability; and
11. Economic and Financial Model Viability.

The business recommendations are based on global best practices and know-how (detailed in Chapter 3) combined with information gathered from key informants and sight visits during an initial fact-finding trip to Kenya.

## **1. WASTEWATER-FED AQUACULTURE**

### *1.1 Market viability*

#### Known: Aquaculture situation analysis.

Aquaculture is a small but rapidly growing sector in Kenya, making it an ideal time to enter the business and to leverage the profit potential for the benefit of the sanitation sector. Expanding aquaculture is a core goal of the Kenyan government’s strategic development plans. In 2009 the government launched the Fish Farming Enterprise Productivity Economic Stimulus Programme, investing 1.2 B KES (USD 13.4 M) in pond construction, followed by a 3 B KES (USD 33.5 M) investment in for post-harvest infrastructure under the same program in 2010. Overall, the program is responsible for supporting 28,000 new fish farmers and indirectly creating employment of over 140,000 other Kenyans in aquaculture-related jobs [80]. The push for aquaculture development comes as a result of increasing demand for fish – growing population, increasing incomes – in the face of rapidly diminishing wild catches. Ninety percent of capture fisheries are on Lake Victoria and the remainder come from the Indian Ocean but total wild catches have dropped by 50% in the last decade [81].

Presently, farmed fish production amounts to 7000 tons per year with the short-term aim to achieve at least 20,000 tons per year. Tilapia constitute roughly 90% of the aquaculture industry but demand for catfish has been rising over last several years [82]. One major constraint to the aquaculture industry's growth is a shortage of producers of high quality and large volumes of fingerlings. According to the Ministry of Fisheries Development, there are only 20 companies nationwide producing high quality fingerlings, and of these only two produce all-male tilapia, which are highly preferable to mixed sex stock for commercial fish farming. Furthermore, only a few suppliers have the expertise to rear catfish fingerlings, which has stymied the growth of that consumer market.

Affordable and high quality feed is another weak link in the aquaculture value chain. Industrial-scale feed producers only emerged in Kenya over the last couple of years, so their numbers are few and their quality remains unproven [81]. Furthermore, these manufactured feeds remain extremely expensive compared to the revenues from fish. Many fish farmers rely on agricultural by-products and mix their own feed. With the boom in the number of fish farmers, both fingerling and fishmeal production will hopefully become more competitive and reliable.

#### **Wastewater-fed aquaculture opportunity**

Among the more than 40 sewage treatment plants in Kenya, waste stabilization ponds (WSPs) are the most common<sup>6</sup>. These WSPs are in various states of disrepair due to inadequate operation and maintenance, which undermines their potential public health and environmental benefits [83]. Wastewater-fed aquaculture presents a ready opportunity to improve the operational capacity of these treatment ponds (see e.g. the case study in Chapter 3) while simultaneously contributing to the national effort to expand fish farming.

Ruai, outside Nairobi is home to the Kenya's largest WSP – and the second largest in Africa – serving roughly 2 million Nairobians (Figure 10). The Ruai system receives about 95,000 m<sup>3</sup> wastewater/day, which is distributed among eight parallel series of ponds. Each series contains a facultative pond and three maturation ponds, and the newer series also include anaerobic ponds (Figure 11). The system's eight parallel series make it an ideal site for conducting comparative

---

<sup>6</sup> In fact, WSPs are in widespread use around the world. In Africa, they are particularly common in Kenya, Morocco, Egypt, Tanzania, Malawi, Zambia, South Africa, and Mozambique. In Asia, there are large numbers in India, Indonesia, and Vietnam; in Latin America, they are found in Mexico, Brazil, Argentina, and Peru. Among developed countries, there are over 2,500 in both France and Germany, about 7,000 in the US, and several in Spain and Portugal.

pilot-scale cultivation experiments to ascertain e.g. the optimal species, stocking density and feeding regime to maximize profits.

WE held meetings with the Head Engineer for the Nairobi Water and Sewage Company that owns and operates the Ruai treatment plant and also with the Head of the laboratory at the facility. Both parties expressed a keen interest in exploring the feasibility of commercial aquaculture in the maturation ponds of the treatment plant.

In sum, the Kenyan market for fish and the institutional support for growing the aquaculture sector make fish farming a very attractive business venture. Early entrants will have the advantage of capturing a less competitive market but will also face the inherent constraints of the still nascent supporting industries, such as fingerling and feed suppliers and distribution networks.



**Figure 10. Nairobi, Kenya with respect to the Ruai sewage treatment plant, a waste stabilization pond system that serves approximately 2 million of the city's inhabitants.**

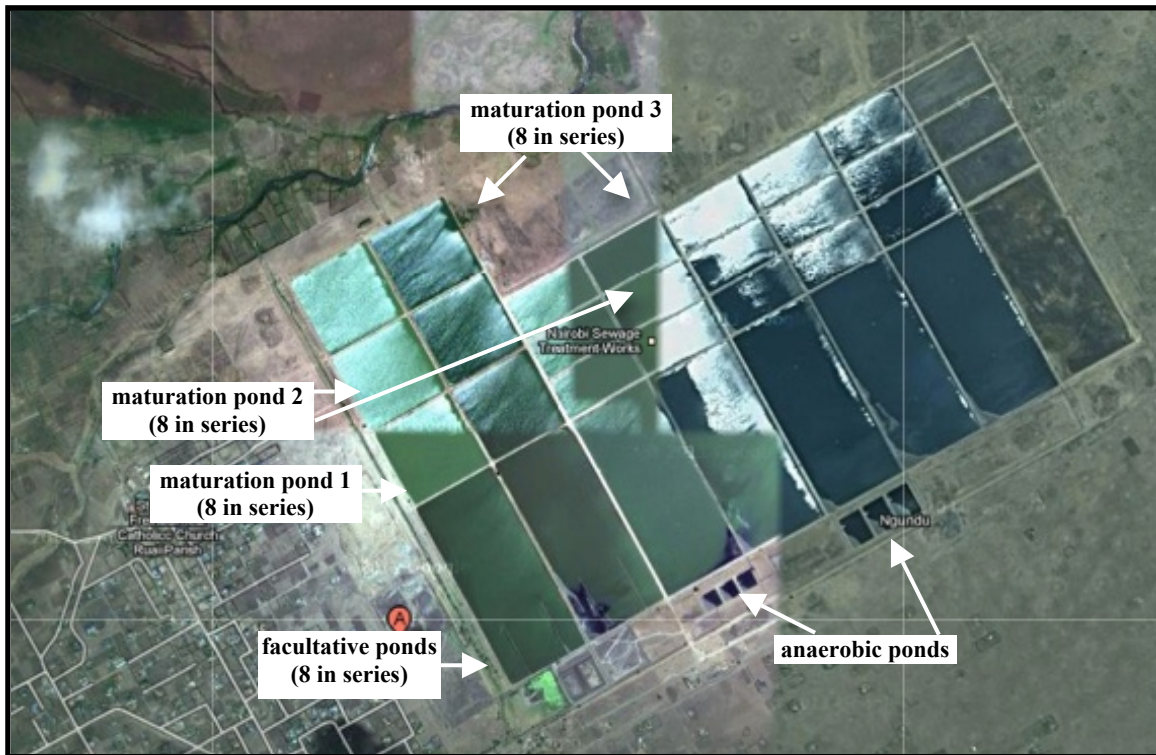

**Figure 11. Ruai waste stabilization pond system comprising eight parallel series of ponds. Wastewater flows first into the anaerobic ponds, where available, next to the facultative ponds, and finally through the three maturation ponds. The total retention time averages 60 days.**

Unknown: Market willingness to consume wastewater-fed fish.

While the demand for conventionally farmed fish appears quite reliable and in excess of current supply, this does not translate to market willingness to consume fish farmed in partially treated wastewater. Prior to launching a commercial venture, a perspective wastewater-fed fish farmer would have to conduct market surveys among consumers, wholesalers, and retailers of fish to ensure they would have a market for their product. In addition to surveying markets for fish consumed by humans, an entrepreneur can also investigate markets for animal feed inputs.

### *1.2 Technical viability*

Known: Wastewater-fed aquaculture is technically viable.

As described in the aquaculture section in Chapter 3, wastewater-fed aquaculture is a widespread practice. On the other hand, it typically occurs in an unregulated and informal manner, thus there is little understanding of the public health risks and impacts of working with or consuming the



fish. Because of the limited research that has been done on wastewater-fed aquaculture there is limited published knowledge on best management practices and coping mechanisms for the circumstances and conditions that are unique to wastewater-fed aquaculture. To that end, WE is working to develop best practices in wastewater-fed aquaculture and also a mutually beneficial business model for fish farmers and treatment plant proprietors (see Chapter 3, Box 9) that should be transferable to other countries, including Kenya.

Unknown: Viability of wastewater-fed aquaculture in Nairobi's wastewater treatment plant.

Prior to launching a commercial aquaculture enterprise, there are several questions to be answered related to the technical viability of wastewater-fed aquaculture at the Ruai WSP. Foremost is determining whether the water quality in the maturation ponds is suitable for fish survival and for cultivating fish for human consumption. The treatment plant receives not only domestic wastewater but also industrial wastewater, so there may be constituents in the influent that render the water unfit for fish farming. Elevated heavy metal concentrations would be the most obvious concern because they are not effectively removed by WSPs and if present, would accumulate in the muscle tissue of the fish.

According to the head of the laboratory at the Ruai WSP, industries must apply for a license to discharge their wastewater into the sewer system leading to the plant, and ultimately, many are required to pre-treat prior to discharge. In this way, the Nairobi Water and Sewage Company has some control over the toxicity of the wastewater they receive and according to the head of the laboratory, the influent does not contain a lot of heavy metals. The facility has water quality records that can be reviewed, and additional soil and water samples from the maturation ponds should be collected and analyzed over a period of several months to confirm that the metal concentrations fall within safe limits for fish farming.

Assuming that the heavy metal concentrations are sufficiently low, adequate dissolved oxygen and low ammonia-nitrogen levels are the most critical water quality parameters for fish survival. Again, the treatment plant's own records can be analyzed and a dedicated aquaculture feasibility study of the three maturation ponds in each series should be conducted over a period of several months. Ideally, after initial water quality analysis of all maturation ponds, a sub-set of ponds would be stocked with tilapia and/or catfish while carrying out further water quality testing. Fish would be sampled (using a drag net) every two weeks to monitor the actual survival rates and growth in light of water quality results. A study that compared the growth and survival of different species in equivalent ponds (i.e. the third maturation ponds) and in different ponds (i.e.

second maturation pond versus third) would be especially useful in preparation for commercialization.

Table 16 provides a set of guiding goals for a technical feasibility study of implementing commercial aquaculture at the Ruai WSP.

**Table 16. List of suggested objectives and associated approaches, outcomes and assumptions to guide the technical feasibility study of wastewater-fed aquaculture at the Ruai Waste Stabilization Pond in Kenya.**

<b>Objective</b>	<b>Approach/Methods</b>	<b>Desired Outcome</b>	<b>Assumptions and Risks</b>
Ensure that heavy metal concentrations fall within safe threshold for farming fish for human consumption	Standard lab techniques	Heavy metals (e.g. Hg, Cd) are below WHO's safety threshold. Soil should also be sampled, especially if considering catfish farming.	Assumes heavy metal concentrations in water and soil in maturation ponds will meet WHO guidelines for wastewater-fed aquaculture
Characterize water quality in Maturation Ponds 1, 2, and 3 in series with and without anaerobic ponds	Standard lab techniques	Quantify dissolved oxygen, BOD, ammonia-nitrogen, fecal coliform,	Assumes dissolved oxygen and other critical water quality parameters for fish survival will be adequate in at least Maturation Pond 3 in each series
Identify which maturation ponds are suitable for aquaculture	Analysis of water quality results	Water quality meets WHO standards for wastewater-fed aquaculture	Assumes at least Maturation Pond 3 in each series will meet standards, perhaps earlier maturation ponds;
Demonstrate and compare fish growth and survival in ponds that meet minimum water quality thresholds	Fish sampling every two weeks (using dragnet) over the cultivation period; fish counted and average weight taken	At least 65% survival from stocking to harvest (6-month cultivation); Growth compared to standard growth curves for given fish species; Results contribute to detailed operating protocol	Assumes growth and survival rates may vary between ponds due to differences in water quality and other unmeasured characteristics
Demonstrate fish safety for human consumption (without and/or with depuration)	Tilapia and catfish muscle tissue sampled at start, middle and end of cultivation to quantify select pathogen and heavy metal concentrations	Flesh concentrations of pathogens and metals do not exceed WHO standards and/or additional safety measures (e.g. smoking prior to public sale) explored	Heavy metals may accumulate in flesh, making fish unsafe for consumption
	Sub-set of fish subjected to 3-day post-harvest depuration with freshwater and indicator pathogen and metal concentrations monitored	Results contribute to detailed operating protocol	
Compare growth and survival of tilapia,	Fish sampling every two weeks (using dragnet)	Growth and survival statistics for each fish	Different species may adapt better to water quality

catfish (monocultures) and polyculture of tilapia and catfish	over the cultivation period; fish counted and average weight taken	species and culture condition over course of 6-month cultivation period; Results contribute to detailed operating protocol	characteristics and food availability in maturation ponds
Identify and mitigate local hazards to fish growth and survival	Fish sampling every two weeks	Potential predators identified and removed from fish ponds (e.g. crocodiles, hippos)	Assumes current inhabitants of ponds may pose a threat to the growth and survival of fish; Fish survival may be confounded by several factors

### 1.3 *Business model viability*

Known: Partial understanding of competition, competitive advantage, and risks.

There are several components of business model viability that must be considered when evaluating the overall feasibility of a new business venture, including competition, competitive advantage, barriers to entry, and risks and mitigation strategies.

#### **Competition and competitive advantage**

There appears to be much room in the aquaculture sector for new entrants, as demand for farmable fish species exceeds current supply. A wastewater-fed fish farmer is privy to two crucial competitive advantages over conventional farmers: occupation of ready-made ponds, and use of nutrient-rich water that eliminates or offsets the need for fishmeal. In fact, wastewater-fed fish farming effectively negates what are usually the biggest start-up and operating costs, respectively. This presents a particularly important advantage in Kenya where fishmeal is expensive and difficult to procure.

Given these advantages, a successful wastewater-fed aquaculture business in Kenya will be vulnerable to copycats who seek to replicate the model at other WSPs across the country. From the perspective of the sanitation sector, this is of course, a good thing. From the perspective of the aquaculture company this is a clear threat. But wastewater-fed fish farming is not the same as conventional aquaculture, so the first entrepreneur is likely to maintain the advantage of experience over his copycats for several years. One way for the aquaculture company to reap rewards for taking the pioneering risk, while still allowing the model to spread rapidly across the country, would be to develop and sell a “starter kit” containing best management practices, operating protocols, and information on forging contractual agreements with WSP proprietors among other tips.

## **Risks**

There are a number of risks that can be readily identified. As already noted, market willingness to consume/purchase wastewater-fed fish is not understood. However, even if a market survey reveals consumer reluctance this could likely be overcome through a carefully planned and executed education and marketing campaign to make known the safety of the fish and the business's contribution to environmental sustainability.

Insufficient fingerling quantity and quality are known constraints to growth of the aquaculture industry in Kenya, and a business risk for any fish farmer. Difficulty accessing fingerlings when needed could be the difference between two and one complete harvests per pond per year. And poor quality fingerlings are susceptible to much higher mortality rates than those from a hardy brood. A seasoned aquaculture entrepreneur could choose to produce his own fingerlings to give himself complete control over the size, quality and availability of fingerlings.

The viability of the aquaculture business at Ruai (or any other WSP) relies on the company/entrepreneur having access to the maturation ponds. While the Nairobi Water and Sewage Company is currently like the idea of establishing aquaculture at the Ruai WSP it is possible that a future change in, for example, management or operating policies at the NWSC, could compromise or prevent the aquaculture company's access to the ponds. Furthermore, as the partnership would be reliant upon the contract enforceability for access to the ponds, any loss of access would result in significant financial losses for the entrepreneur. If the NWSC chooses not to honor the terms of a contract there may be little recourse through the Kenyan court system given that the NWSC is a subsidiary of the Nairobi City Council.

Unknown: Supply chain logistics, compliance requirements, terms of access to WSP.

Any newcomer to the aquaculture sector in Kenya will have to embark on developing supply chains for the inputs and outputs of the business. In addition, prior to start-up the entrepreneur will have to identify and ensure they are able to meet all compliance requirements for selling fish farmed in partially treated wastewater.

Finally, and perhaps most importantly, the business model hinges on the terms of pond access and usage that the entrepreneur negotiates with the NWSC. Since aquaculture falls outside the scope of their own business mandate, the NWSC does not have the legal grounds to pursue fish farming as a commercial activity on their own. The NWSC can, however, enter into a partnership with a

third-party aquaculture company as long as the partnership emerged via the NWSC’s strict procurement policies, which include a public bidding process.

At this exploratory stage, the NWSC has not expressed any specific expectations from the partnership. But should they reach the negotiating stages, they can and should use such a partnership toward improving their own operating performance and achievement of their wastewater treatment mandate. For example, the NWSC could implement one of a number of partnership structures where the fish farmer pays a fixed rent, a portion of their revenues, or provides in-kind infrastructure or labor to the plant that would ultimately help improve its effluent quality, reliability or financial solvency. The NWSC’s demands must be realistic and financially fair for the aquaculture entrepreneur. Indeed, the aquaculture entrepreneur must ensure that mutually beneficial terms can be reached prior to investing too much time or resources into the business development process. Table 17 provides a set of guiding goals for a business model feasibility study of implementing commercial aquaculture at the Ruai WSP.

**Table 17. List of suggested objectives and associated approaches, outcomes and assumptions to guide the business model feasibility study of wastewater-fed aquaculture at the Ruai Waste Stabilization Pond in Kenya.**

<b>Objective</b>	<b>Approach/Methods</b>	<b>Desired Outcome</b>	<b>Assumptions and Risks</b>
Refine estimates of operating costs and potential profitability based on pilot-scale results	Based on actual costs incurred during feasibility phase	Refined business plan completed	Assumes results from feasibility study can be accurately scaled up and prices will remain accurate by the time of commercialization
Understand farm-gate fish selling system and identify potential buyers	Interviews with fish farmers and sellers	Aquaculture supply chains developed and networks established with local buyers	Assumes no abrupt changes to system or buyers between feasibility study and commercialization
Ensure buyers willing to purchase wastewater-fed fish	Network building with fish buyers	Signed letter of intent from two or more potential buyers	Buyers may not want to risk their reputations by purchasing fish from the WSP
Identify reliable suppliers of fingerlings	One or more suppliers identified	Aquaculture supply chains developed	Assumes suppliers will meet quality and quantity requirements
Identify all compliance requirements for implementing commercial (wastewater-fed) aquaculture in Kenya	Interviews with officials from key government ministries (e.g. Fisheries, National Environmental Management Association), existing fish farmers	Detailed report on compliance requirements, methods and expected timeline for attainment	Assumes compliance requirements can be met for a wastewater-fed system
Establish mutually	Possible public-private	Terms for a tender	Nairobi Water and

acceptable and enforceable terms and conditions for PPP between Nairobi Water and Sewage Company and aquaculture entrepreneur	partnership structures explored	process written and ready to publish for bidding	Sewage Company loses interest in project
---	---------------------------------	--	--

#### 1.4 Economic and financial model viability

Assuming that public health safety standards can be met, the results of the feasibility study will shed light on the possible scale for commercial fish farming at the Ruai WSP. The most binding constraint is water quality and ability of fish to survive in different ponds. If one assumes the conservative stocking scenario whereby the third maturation pond in each series is the only one with sufficient water quality, this amounts to a harvest of nearly 2,000,000 fish every six months. Table 18 shows the projected costs and revenues for such a scenario. At the scale of operation that might be possible at Ruai, one may risk approaching the market demand limit (at a given time or for a given buyer) for tilapia and/or catfish. Though, that constraint should be simple to address by staggering the stocking and harvesting dates of different ponds, thus smoothing the cost and revenue streams for the farmer as well.

**Table 18. Projected costs and revenues for an aquaculture enterprise in eight maturation ponds of the Ruai WSP, which serves the city of Nairobi, Kenya. Values assume one 6-month cultivation period.**

	Unit Cost (USD)	Total (USD)	Assumptions
<i>Start-up costs</i>			
Tilapia fingerlings	0.07/fingerling <sup>a</sup>	210,000	Stocking density = 3/m <sup>2</sup> ; 8 maturation ponds stocked; Each pond = 125,000 m <sup>2</sup> Nets, buckets, scales for sampling and harvest Ferro cement tanks gravity fed by polytanks holding freshwater
Aquaculture tools		3,000	
Depuration tanks (optional) <sup>b</sup>		?	
<b>TOTAL CAPITAL</b>		<b>~213,000</b>	
<i>On-going costs</i>			
Aquaculture operations manager	1500/mo <sup>c</sup>	9,000	Responsible for staff oversight, sourcing, distribution, marketing 1 laborer/2 ponds; 6 mo employment (cultivation) period 4 guards employed
Fish pond laborer	150/mo <sup>d</sup>	3,600	
Night guard	150/mo <sup>d</sup>	3,600	1 sampling event/month throughout cultivation 20 day laborers/day for 3 days
Fish feed	NA	NA	
Quality assurance (fish flesh testing)	250/sampling event	1,500	
Harvesting (day laborers)	25/day/laborer	1,500	
Freshwater for depuration (optional) <sup>b</sup>	0.33/m <sup>3</sup>	?	
Contingency (unexpected costs)		3,000	

<b>TOTAL O&amp;M COSTS (per 6-month cultivation)</b>		<b>~22,200</b>	
		<i>Revenues</i>	
Tilapia sales	2.3/kg <sup>e</sup>	2,242,000	65% survival; 500 g/fish at harvest
<b>TOTAL PROFITS</b>		<b>~1,997,000</b>	

<sup>a</sup>Source: [84]. <sup>b</sup>There is not enough information available to estimate this cost. Furthermore, the efficacy of depuration is debated and should be trialed for a particular system prior to investing in a full-scale system. <sup>c</sup>Based on PayScale.com. <sup>d</sup>Source: [85]. <sup>e</sup>See: [86].

### **Expansion opportunities**

Assuming aquaculture proves technically and economically viable at the Ruai WSP, there is enormous opportunity for expanding the business across Kenya. As noted above, there are close to forty waste stabilization pond systems in Kenya. Surveying the suitability of those ponds for aquaculture was outside the scope of this study but should be a next step upon a successful pilot at Ruai. Of course, as noted among the risks above, the pioneering entrepreneur may have to compete with copycat fish farmers to win contracts at future WSPs.

Within three to five years of establishing operations at the Ruai WSP, a fish farmer should have acquired the capital and site-specific experience to operate at the system's full capacity.

In addition, there may be an opportunity to use a portion of the vast open land at around the WSP for horizontal expansion of irrigated agriculture. The aquaculture company would thereby divert effluent from the fish ponds to the fields for growing a high-value agricultural product. Potential vertical expansion options include branching into fingerling farming and post-harvest processing. The latter might in fact be part of a Hazard Analysis and Critical Control Point (HACCP) plan that gives the farmer more control over the public health safety of the fish prior to going to market.

#### *1.5 Key partners*

Table 19 presents a list of partners that have been identified as key to exploring and implementing a wastewater-fed aquaculture business at the Ruai WSP in Nairobi. As one embarks on the business feasibility study this network will likely expand substantially.

**Table 19. List of key institutional and research partners for implementing an aquaculture enterprise at the Ruai Waste Stabilization Pond system.**

Name	Affiliation
<i>Institutional partners</i>	
J.P. Kimani	Technical Director, Nairobi Water and Sewage Company
Joseph Kamau	Treatment Works Coordinator at Ruai WSP, Nairobi Water and Sewage Company
Mbugua Mwangi	Directorate of Aquaculture, Ministry of Fisheries Development
<i>Local Research Partners</i>	
Harrison Charo	Head of Research at National Aquaculture Research, Development and Training Centre in Sagana, Kenya Marine and Fisheries Research Institute
Michael Kimenye Thiga	Head of Laboratory at Ruai WSP, Nairobi Water and Sewage Company Fisheries Department, Moi University (Eldoret, Kenya)

## 2. URINE AS FERTILIZER

### 2.1 Market viability

#### Known: Agriculture situation analysis.

The agriculture sector employs nearly three-quarters of Kenya’s work force (including subsistence farming, which is about half) and accounts for about 25% of the country’s GDP [87]. Tea, coffee, cashews and cut flowers are among the primary cash crops. In fact, Kenya is responsible for 60% of flower exports from Africa and 6% of the global flower export market.

With a large agriculture sector comes a large demand for mineral fertilizers across Kenya. As of 2009, annual consumption of fertilizer reached approximately 2 million metric tons (Figure 12).

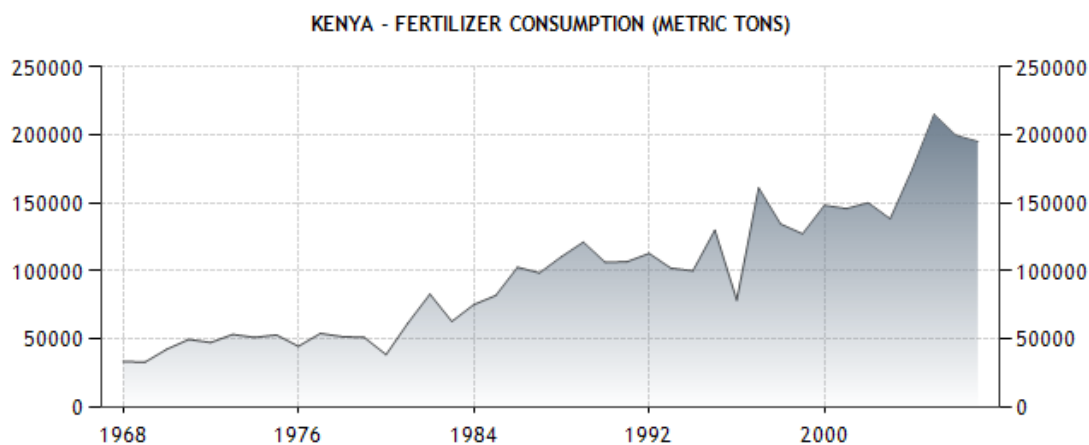

**Figure 12. Fertilizer consumption – including nitrogenous, potash, phosphate – in Kenya between 1967 and 2009. (Reproduced from: TradingEconomics.com [88].)**



Ninety-five percent of this fertilizer is imported and distributed by the private sector, a consortium of importers, wholesalers and retailers [87]. The system is an artifact of the Government of Kenya’s agricultural reforms in the 1980s, whereby the government exited the fertilizer market. Despite the government’s positive intentions, leaving it entirely to the private sector to import and distribute fertilizers has resulted in limited access to fertilizer among smaller landholders [87, 89]. Affordability is a major factor, and the high farmgate prices stem from a combination of limited supply of imports, high import fees and levies, and high transport costs from the port to retailers [87]. While the retail price of fertilizer was fairly steady in the early 2000’s it shot up dramatically in 2008 (Table 20).

**Table 20. Price trend (Kenya Shilling) for 50 kg urea fertilizer in Kenya between 2000 and 2008. 1 KES = 0.01 USD.**

	'00-01	'01-02	'02-03	'03-04	'04-05	'05-06	'07-08
<b>Urea (KES/50 kg)</b>	780	750	900	1,250	1,400	1,450	1,600
<b>Urea (USD/50 kg)</b>	7.8	7.5	9.0	12.5	14.0	14.5	16.0

Source: Republic of Kenya, Ministry of Agriculture.

#### **Urine-to-fertilizer business opportunity**

Researchers have consistently shown that fertilizer usage in Kenya is lower than it should be for yield and profit maximization [87, 90]. In light of the bottlenecks to making chemical fertilizers more accessible, there appears to be a very good market opportunity to introduce human waste-based fertilizer to the sector. Waste-based fertilizers can be processed from free (or inexpensive) feedstocks, would avoid import fees and levies, and production can be decentralized such that transportation of the inputs and distribution of the finished product is minimized.

Urine, the waste stream in which nutrients are concentrated, stands out as being ripe for development as a marketable fertilizer in Kenya. As described in Chapter 3, conventional latrines and toilets make urine recovery unrealistic because it is mixed with feces and is diluted with water. In Nairobi, however, the innovative social enterprise, Ecotact, is providing the foundation to make urine recovery possible by installing urine-diverting toilets.

Ecotact is revolutionizing public sanitation in Kenya with their Ikotoilets – clean, consistent multi-service blocks that include not only toilets but also showers, vendors, and shoe-shining among other services. As of 2011, they had built 50 Ikotoilets across the city of Nairobi, plus ten at schools. Their target is to reach 100 urban and 100 school facilities by 2015. Each urban

facility serves about 1000 patrons daily and all of the blocks are currently connected to Nairobi's main sewer system.

Unknown: Market willingness to use urine-based fertilizer.

As has been emphasized throughout this report, the market may initially be reluctant to adopt human-waste-based products. An important part of the business feasibility study will be to conduct market surveys among farmers and fertilizer retailers to gauge acceptance of urine-based fertilizer.

*1.2 Technical viability*

Known: Urine is accessible in Nairobi and makes an effective fertilizer.

Recognizing the resource value of urine, and wanting to allow for its future harvest, the Ikotoilets are designed to divert urine from water and feces. Thus, the urine is readily accessible without any retrofits to the existing Ikotoilet model. WE met with David Kuria, the founder of Ecotact, and he is keen to partner with an entrepreneur who is interested in processing and marketing the urine as fertilizer.

As discussed in Chapter 3, urine is rich in nutrients vital to plant growth and those nutrients are in forms that are readily taken up by plants. Replacing the use of urea/nitrogen fertilizers with human urine would create a closed-loop cycle, returning to rural areas the nutrients that are stripped from the soil and exported to cities in the form of food. The challenge, however, is finding a cost-effective and socially acceptable means of doing so (see Chapter 3, Box 1).

Unknown: The best way to process and market urine-based fertilizer on a commercial scale.

As discussed in Chapter 3, the production of urine-based fertilizer on a commercial scale has never been demonstrated. Thus, there is much front-end research and development that needs to take place prior to launching a commercial fertilizer business. Product development is the foremost priority, and this should be informed by the market demand and preferences. There are essentially two modes by which urine could be processed and sold: as a dried powder/pellet or as a liquid foliar fertilizer<sup>7</sup>. In 2010, with support from the Dutch organization, WASTE, Ecotact teamed up with the Jomo Kenyatta University of Agriculture and Technology on a research project to produce struvite, a powdered urine-based fertilizer. The team made significant scientific

---

<sup>7</sup> These are liquid fertilizers that are applied directly to the plant's leaves and the minerals are absorbed through the stomata. Urea-based products are the most common form of foliar fertilizer.

strides, and the product they have developed would be a good starting point for developing a pelleted product.

Nancy Karanja, an urban agriculture expert and soil scientist in the Faculty of Agriculture and Veterinary Sciences at the University of Nairobi, believes that processing the urine as a foliar fertilizer is the best approach [91]. She believes this would be the easiest and most cost-effective means of processing and transporting the urine, and that it would also be highly marketable. There are some foliar fertilizers available in Kenya but being imported they are of course very expensive.

The choice by a private company to produce one or both of these products should be based on a thorough investigation of the market demand for powder/pellets and foliar fertilizers, as well as analysis of the expected costs and revenues of producing each of these urine products. A study should also be conducted on the agricultural efficacy of each through controlled field trials.

Table 21 provides a set of guiding goals for a technical feasibility study of developing a urine-based fertilizer product.

**Table 21. List of suggested objectives and associated approaches, outcomes and assumptions to guide the product development research for using urine as a fertilizer.**

<b>Objective</b>	<b>Approach/Methods</b>	<b>Desired Outcome</b>	<b>Assumptions and Risks</b>
Evaluate agricultural efficacy of urine-based pellets and foliar fertilizer compared to conventional substitutes	Experimental plots set up and monitored for one cultivation season for various crops; Standard parameters for agricultural field trials measured, e.g. leaf area index, leaf chlorophyll content, total dry mass yield	Plants perform as well or better than conventional substitutes	Results will not be biased or confounded by any uncontrolled factors
Develop a scalable manufacturing process for producing urine-based pellets and/or foliar fertilizer	Develop and build pilot-scale manufacturing apparatus	Designs and bill of sale for full-scale processing equipment	Assumes technology exists/can be developed in Kenya to produce a pellet and/or foliar fertilizer from urine
Develop quality control and assurance protocols for manufacturing process	Quality control and assurance procedures developed	Fertilizer quality is consistent and of high quality	Non-urine-borne contaminants may periodically get into urine holdings at Ikotoilet blocks that entrepreneur does not detect but that affect

Demonstrate public health safety of the product(s)	Standard lab techniques for pathogen detection	Fecal pathogens are not detected in/on the finished urine-based fertilizer product	product quality Urine processed and/or stored for a period of 4-6 weeks should be free of detectable pathogens
--	--	--	---

### 1.3 Business model viability

Known: Partial understanding of competition, competitive advantage and risks.

Like the wastewater-fed aquaculture business-feasibility outline, aspects of competition and a sub-set of competitive advantages and risks associated with a urine-based fertilizer business can be readily identified.

#### **Competition and Competitive Advantage**

The fertilizer sector is starved for a high quality yet affordable product that is accessible to small farmers. The competition faced by a urine-based fertilizer entrepreneur will thus depend on the price point of their product. If the entrepreneur is able to undercut the price of imported conventional phosphorus or urea/nitrogen fertilizers than they will have staked out a very competitive position for themselves. If the cost of production is such that the retail price is equivalent to, or more than, conventional alternatives, the entrepreneur may still find a niche market among farmers seeking organic products. According local agricultural specialists there is increasing demand for organic products, particularly among horticulturalists who are exporting to Europe. Thus, an entrepreneur should be able to leverage favorable pricing and at the very least, the “organic” label to their competitive advantage.

An entrepreneur who successfully develops and launches a urine-based fertilizer business will be in possession of a unique and difficult-to-copy product. First, there is the fact of the time and resource intensive product development phase. And second, is the accessibility of urine. The terms of an entrepreneur’s agreement with Ecotact could ensure that he has first rights to urine at the Ikotoilet blocks in a given geographic region and/or with the company overall. Given the need for urine-diverting toilets it would be difficult for anyone who is not working with Ecotact to imitate the business model on a commercial scale. On the other hand, if the business model proves lucrative it may spur the copycat construction of urine-diverting toilet blocks and associated fertilizer companies. From the perspective of the sanitation sector, this would indeed be a successful outcome.

## **Risks**

Dependence on the Ikotoilet: As mentioned above, the design of the Ikotoilet is unique in that it diverts urine from the feces and flush water. Thus, the ability of the fertilizer entrepreneur to thrive will depend on the continued success of Ikotoilets and the continued willingness of Ecotact to collaborate. Should Ecotact pull out the agreement, the entrepreneur stands to lose a substantial capital investment.

Market willingness to buy urine-based fertilizer: Farmers' general acceptance of the product should be determined well in advance of launching a commercial business. Successful demonstration plots, competitive pricing and strategic marketing should be able to overcome these challenges. Of course, if there are any inconsistencies in the fertilizer's quality or supply, or if farmers experience difficulty using the product, market demand may drop or may not meet initial projections.

High production and marketing costs cannot compete with chemical fertilizers: Full-scale production costs and unforeseen challenges with logistics may make the fertilizer less cost-competitive with conventional fertilizers.

Unknown: Details of market demand, compliance requirements, terms of access to urine.

A prospective urine-based fertilizer entrepreneur will require a keen understanding of the specific fertilizer preferences of different farmer groups, thereby informing their product development, and customer targeting and marketing campaigns. They will also need an understanding of compliance requirements for producing and selling a urine-based fertilizer. The aforementioned market and logistical research should be quite straightforward and to further guide the research process are a set of suggested objectives and approaches in Table 22.

Assuming one is technically able to produce a cost-effective urine-fertilizer product, perhaps the biggest determinants of the business model viability are the logistics of collecting and transporting the urine to a central place for processing, and the entrepreneur's terms of access to the urine with Ecotact. The overall business viability could prove quite sensitive to the cost and reliability of urine collection and transport logistics. Thus, developing this supply chain will be a major component of the feasibility study and guiding objectives and methods are provided in Table 22.

Regarding access to urine, Ecotact, being a private company, is likely to expect financial compensation or another form of benefit stream in exchange for being a facilitator of the urine fertilizer business. One could imagine various forms of partnerships or joint ventures, from

Ecotact being an investor/shareholder in the fertilizer business, to Ecotact selling the urine feedstock to the fertilizer company, to the fertilizer company paying a flat fee or percentage of their revenues to Ecotact. Without a better understanding of the costs and expected revenues from the fertilizer business it is too early to make conclusions about the best model for either party but should be negotiated during the business model feasibility study (Table 22).

**Table 22. List of suggested objectives and associated approaches, outcomes and assumptions to guide the business model development research for using urine as a fertilizer.**

<b>Objective</b>	<b>Approach/Methods</b>	<b>Desired Outcome</b>	<b>Assumptions and Risks</b>
Quantify local and national market (latent demand for nitrogen pellet and foliar fertilizers)	Key informant interviews and surveys with farmers, fertilizer wholesalers and retailers, relevant government agents; archival review	Comprehensive report on the spatial and temporal distribution and scale of market for nitrogen fertilizers in Kenya	Assumes informants will provide reliable information
Ensure farmers' willingness to purchase urine-based fertilizer	Farmer outreach through existing organizations; trial sales	Readily take up the product(s)	Assumes information and feedback gathered during outreach will translate to commercial scale
Develop a marketing strategy	Work in collaboration with farmer-capacity-building organizations (Mazingira Institute)	Product name chosen; Packaging designed; Advertising strategy in place	Assumes the product can be successfully marketed
Quantify capital cost of equipment required for pellet and/or foliar product; identify sources for replacement parts	Constructing bill of sale for equipment, gathering and summing prices	Reliable cost estimate	Assumes any changes to price estimate by time of implementation would be small or predictable
Identify location where urine can be processed	Determine size and type of premises required; Locate suitable land/buildings available for rent and purchase	A short-list of potential locations that meet cost, geographic and other key criteria	Assumes locations will remain available by time entrepreneur is ready to secure property
Develop strategy and business model for urine collection and transport to processing site and storage (if necessary)	Evaluate capital and operating costs, necessary equipment and workforce required for technically viable collection and transport options; conduct small-scale trials	Detailed supply chain and protocol for collection, transport (and storage) at full-scale	The ability to process a fertilizer product hinges on the efficacy and cost-effectiveness of this supply chain
Develop supply chains for product distribution and sales	Map requirements of input, distribution and supply chain and identify appropriate players	Detailed supply chains developed	Assumes permanent presence of identified players in the supply chain

Refine estimates of manufacturing costs and develop product pricing strategy	Develop cost and revenue projects based on operating costs of pilot-scale system and data collected from the market demand study	Refined business plan completed; target market clearly defined	Assumes results from feasibility study can be accurately scaled up and prices will remain accurate by the time of commercialization
Determine management and personnel needs from collection to fertilizer sales	Outline job titles, responsibilities, relevant background, experience, skills, expected cost	All preparation for launching candidate searches	A position or human resource/skill need may be overlooked at the pilot scale
Identify all compliance/permit requirements for manufacturing and selling fertilizer in Kenya	Contact key informants including Ministry of Agriculture, National Environmental Management Association, existing fertilizer sellers	Detailed report on compliance/permit requirements, methods and expected timeline for attainment	Assumes compliance requirements can be met for a urine-based fertilizer
Establish mutually acceptable and enforceable terms and conditions for partnership between Ecotact and fertilizer entrepreneur	Collaboration with Ecotact from the project's outset followed by negotiations once a product and business strategy is in development	Signed letter of intent from Ecotact to collaborate with a fertilizer entrepreneur	Assumes Ecotact's business model and management will remain open to the partnership

#### 1.4 Economic and financial model viability

At this stage in the urine-based fertilizer feasibility assessment there remain too many unknowns to develop financial projects for a commercial business. It is, however, possible to roughly estimate the possible scale of a venture based on the volume of urine that is readily accessible in Nairobi (Table 23). Based on the number of Ikotoilets in Nairobi, a fertilizer entrepreneur today could obtain about 13,000 L of urine everyday and by 2015, about 44,000 L daily. In terms of nitrogen content, this would meet the fertilizer demand of close to 300 and 1000 hectares in 2011 and 2015, respectively. A rough estimate of the possible gross revenue based on 2008 nitrogen prices (see Table 20), presents a modest picture indeed (Table 23).

**Table 23. Estimated scale of urine/nitrogen recovery possible from Ikotoilets in Nairobi today and by 2015.**

	2011	2015
Ikotoilet facilities	60	200
Daily urine captured <sup>a</sup> (L)	13,200	44,000
Daily nitrogen equivalent <sup>b</sup> (kg)	92.4	308
Annual nitrogen equivalent (kg) <sup>c</sup>	27,720	92,400
Annual hectares served <sup>d</sup>	277	924
Gross revenue at 2008 nitrogen price <sup>e</sup>	20,328	67,452

<sup>a</sup>Assumes urine capture of 0.22 L/user [92], 1000 users/Ikotoilet; <sup>b</sup>Assumes

7 g N/L [93]; <sup>c</sup>Assumes 300 operating days/year; <sup>d</sup>Assumes nitrogen demand = 100 kg/ha [93]; <sup>e</sup>Assumes N = USD 0.73/kg based on 2008 urea price (see Table 10) and assuming urea is 45% N.

### Expansion Opportunities

Ecotact has a vision to expand their Ikotoilet model not only across urban Kenya but to countries across the continent. Assuming a urine-based fertilizer product can be cost-effectively produced and sold in and around Nairobi, it is conceivable that a fertilizer entrepreneur could continue to trail the growth of Ecotact around the country and African continent. Of course, expansion of the fertilizer business will lag significantly behind expansion of the Ikotoilet, as the toilet blocks must achieve critical mass in a given region for an entrepreneur to have access to enough urine to make a viable business. As seen in Table 23, even 200 toilet blocks would only allow for a very small fertilizer enterprise.

Within five years an entrepreneur should have successfully developed a product and business model, that is capturing, processing and selling all accessible urine in Nairobi. By that time, Ecotact would ideally have achieved enough presence in at least one additional city for the fertilizer business to expand.

#### 1.5 Key Partners

A list of some of the key partners for taking the urine-based fertilizer concept to commercial scale is provided in Table 24.

**Table 24. List of key institutional and research partners for developing and implementing a urine-to-fertilizer business in Nairobi.**

Name	Affiliation
	<i>Institutional partners</i>
David Kuria	Founder, Ecotact
	<i>Local Research Partners</i>
Nancy Kiranja	Jomo Kenyatta University of Science and Technology Department of Land Resource Management and Agricultural Technology, University of Nairobi
Deborah Gathu	Mazingira Institute Kenya Agricultural Research Institute

## 3. SLUM SANITATION

Without question, the biggest sanitation challenges in Nairobi are concentrated in slum areas. Not surprisingly then, the slums are magnets for NGOs and a handful of social enterprises that are



developing and piloting a variety of interventions to improve access and affordability of sanitation for slum residents. While there is little sign of rapid or significant improvements, it is probably safe to assume that these will not come about by adding another entrepreneur with an untested idea to a very crowded field of practitioners.

Thus, where an organization like the IFC can have the greatest impact on slum sanitation in Nairobi is by supporting the business/financial viability of existing efforts. In fact, in keeping with the waste-based business focus of this report, there are a number of reuse-oriented sanitation programs in the slums that could greatly benefit from support for developing vetted business plans that will ensure the long-term sustainability of the products or interventions. Another crucial role for the IFC is as a catalyst for taking successful ideas for scale. Many of the organizations working in the slums have financial or human resource constraints that would prevent a successful model from quickly spreading throughout a slum and to other slums in Nairobi and beyond.

This section introduces three sanitation programs underway in Nairobi slum and suggests ways in which the interventions could be enhanced through a partnership with the IFC.

### *3.1 Umande Trust*

Introduced earlier in this report, Umande Trust is a community-based organization working on improving access to a variety of basic services in slums in and around Nairobi. They are currently active in Kibera, Korogocho, Mukuru, Mathare, Kangemi, Mji Wa Huruma (Nairobi); Obunga, Manyatta, Bandani and Nyalenda (Kisumu) and Dallas in Embu.

Part of Umande's core mission is to work with communities/youth groups to establish income-generating projects, where at least a portion of the revenue goes back to the community. Examples are the Bio Centers, which are the biogas-equipped toilets described above. Umande has the conceptual idea for developing a business model where multi-service Bio Centers generate enough money to be self-sustaining and also to contribute to a fund for building future Bio Centers. When WE met with Umande in May 2011 they expressed an explicit need for professional support with translating the conceptual plan into a viable and executable community-based business plan.

### 3.2 *Peepoople*

The “Peepoo solution” comprises, quite simply, biodegradable plastic bags with a built-in sterilization technology. The bags are used once, sealed, collected or dropped off at a central collection point, and ultimately intended for use as fertilizer. Peepoople launched their very first project in the Kibera slum (Nairobi) in October 2010, where they are piloting the technology with two schools and with individuals through saleswomen in a few “villages” within the slum. They currently sell an average of 1000 peepoo bags everyday and aim to be up to 6000 bags per day by 2013, when the pilot phase comes to a close.

Full bags are collected at two different kiosks in the community. Some users bring them themselves while others rely on an informal door-to-door collection system run by community youth. Peepoople is currently working with researchers at the University of Nairobi to determine the best way to process the bags for future sale as fertilizer. While Peepoople would like to have seen them used directly (which would be safe due to the built-in sterilization technology) it simply is not marketable in Nairobi.

There are several indications that the Peepoo bag is being adopted and well received by local residents. The hook to Peepoople’s innovation? The Peepoo bag presents a *household-level solution* to sanitation that is clean, odorless and hygienic. Users claim to “have toilets” in their homes, and no more do they have to face the sometimes dangerous – particularly at night and for women – and often dirty community toilet blocks that are available in the slum. Technically and socially the Peepoo bag appears well placed to fill a niche market in slum sanitation. However, they have yet to develop a financial model or business plan that can secure the long-term sustainability and scalability of the product and service.

Table 25 shows the economics of Peepoople’s current operating model. Of course, they are simply running a pilot project and the business viability is not yet a top priority. On a promising note, at full-scale production they expect to get costs down from 15 to 7 KES per bag. Yet, without a way to raise the price of the bags while still reaching their target market, eliminate the deposit, and/or find additional revenue streams from the fertilizer or otherwise, Peepoo bags risk becoming another ill-fated NGO project. According to Peepoople’s co-founder, they expect to rely almost entirely on government subsidies. Their thinking is that the Kenyan government, for example, has a responsibility to provide improved sanitation for its citizens, and thus they could do so by allocating funds to Peepoo bags. This seems to be an optimistic outlook at best.

The IFC’s Sanitation and Safe Water for All program may be able to provide precisely the support that Peepoo needs to become a solvent pro-poor sanitation enterprise.

**Table 25. Current economics of the Peepoo-bag business model.**

	Cost (KES/bag)
Cost of production	15
Selling price	3
Refund upon return of used bag	1
<b>Deficit</b>	<b>13</b>

### 3.2 *Ecotact*

WE has gathered some preliminary information on Ecotact’s next sanitation project: a household toilet for slums. Working on the same assumption that drives Peepoo bags – that people prefer to have a toilet in their home – Ecotact has been working with an Israeli design firm to develop a responsive solution. The basic concept is this: households purchase a free-standing toilet that can be placed anywhere in their home. The toilet has a removable base with the capacity to hold roughly four days worth of a household’s (human) waste; the base seals to prevent any odors. Every four days the full base is collected and the contents emptied into a centralized anaerobic digester system. In exchange for the full base, households receive an empty, sterilized base. Ecotact’s revenues thus come from the initial sale of the toilet, the household fee for collection and replacement of full bases, and the sale of biogas/electricity produced by the anaerobic digesters.

Ecotact will soon launch a pilot project to test this technology and business model in the Mathere slum of Nairobi. They have acquired land at an adjacent hospital where they will build the biogas system. The hospital has provided the land for free and in return will receive the biogas at a discounted price for use in their kitchen. Ecotact has not yet worked out the cost of the toilet or the service fees but this will be an exciting business model to watch develop.

This project is very well aligned with the goals of the Sanitation and Safe Water for All program, and should the model prove successful in Mathere, there may be an investment opportunity for the IFC, which would then enable the more rapid transfer and scale up of the system across Nairobi and even outside of Kenya.

## APPENDIX 1: ASSUMPTIONS, DATA AND SOURCES FOR ESTIMATING ECONOMICS OF VARIOUS EXCRETA-REUSE OPTIONS

Medium and reuse	Receiving capacity of end user	Market value of waste as input <sup>a</sup> into production	Incremental benefit and market value	Capital costs	Operation and maintenance costs
Urine as fertilizer	<ul style="list-style-type: none"> <li>• 4 kg N/m<sup>3</sup> urine [92]</li> <li>• 1 crop-cycle ha/100 kg N [94]</li> <li>• 0.5 m<sup>3</sup> urine/pe.yr</li> <li>• 40% urine recovery rate [95]</li> <li>• 2 crop cycles/yr</li> </ul>	<ul style="list-style-type: none"> <li>• Market value of N fertilizers = \$1.2/kg N</li> </ul>	<ul style="list-style-type: none"> <li>• Incremental yield = 0.6 t/ha (with addition of P and K) compared to conventional NPK fertilizer [94]</li> </ul>	<ul style="list-style-type: none"> <li>• Includes 1 urine-diverting dry toilet/hh = \$150/toilet</li> <li>• 30-d storage: urine storage tanks = \$0.1/L; tank diameter = 3.65 m [96]</li> </ul>	<ul style="list-style-type: none"> <li>• Cost of urine handling = \$2.2/hh.mo [95]</li> <li>• 4 pe/hh</li> </ul>
Raw fecal sludge as soil conditioner	<ul style="list-style-type: none"> <li>• 145 m<sup>3</sup>/ha (Based on case study in Manya Krobo, Ghana [97])</li> <li>• 1 application/yr</li> </ul>	<ul style="list-style-type: none"> <li>• Market value of N fertilizers = \$1.2/kg N</li> </ul>	<ul style="list-style-type: none"> <li>• Incremental yield = 2.5 t/ha compared to no addition to soil [98]</li> </ul>	<ul style="list-style-type: none"> <li>• No additional costs</li> </ul>	<ul style="list-style-type: none"> <li>• No additional costs</li> </ul>
Raw fecal sludge for household biogas recovery for fuel	<ul style="list-style-type: none"> <li>• Household demand for cooking fuel or gas-powered lighting</li> </ul>	<ul style="list-style-type: none"> <li>• Value based on retail price of LPG on a thermal energy basis = \$0.013/MJ</li> </ul>	<ul style="list-style-type: none"> <li>• Yield based on 4 pe human excreta plus 3 cows (or equivalent in pigs); Value based on retail price of LPG on a thermal energy basis = \$0.013/MJ</li> </ul>	<ul style="list-style-type: none"> <li>• Anaerobic digester (5 m<sup>3</sup>/household) = \$350/hh [99]; 4 pe/hh</li> </ul>	<ul style="list-style-type: none"> <li>• No quantifiable O&amp;M costs [99]</li> </ul>
Raw fecal sludge for community biogas recovery for fuel	<ul style="list-style-type: none"> <li>• Equivalent fuel demand of 860 households cooking 2 hr per day</li> </ul>	<ul style="list-style-type: none"> <li>• Value based on retail price of LPG on a thermal energy basis = \$0.013/MJ</li> </ul>	<ul style="list-style-type: none"> <li>• Yield based on: 70% collection/pe, 35 kg COD/m<sup>3</sup> FS, 0.35 m<sup>3</sup>/kg COD removed, 70% COD removal; market value based on retail price of LPG on a thermal energy basis = \$0.013/MJ</li> </ul>	<ul style="list-style-type: none"> <li>• Centralized anaerobic digesters = \$585/m<sup>3</sup> (effluent filter, pipe, fittings, excavation) (Personal communication with Ghana biogas contractor Nov. 2010)</li> </ul>	<ul style="list-style-type: none"> <li>• Manager wage = \$900/mo; 2 mangers</li> <li>• Laborer wage = \$150/mo (where Ghana minimum wage = \$103/mo); 10 full-time laborers</li> <li>• Utilities = 2% revenues</li> </ul>

<p>Raw fecal sludge for community biogas recovery for electricity</p> <p>Dewatered FS as soil conditioner</p> <p>Dewatered fecal sludge as industrial fuel</p>	<ul style="list-style-type: none"> <li>• Equivalent electricity demand of 125 KW per day</li> <li>• 1 ha per 7.3 ton FS (at 70% DS)</li> <li>• 1 application/yr</li> <li>• Industry with 5 times greater energy demand than net energy available in the sludge (i.e. fecal sludge can substitute 20% of fuel demand on a thermal energy basis)</li> </ul>	<ul style="list-style-type: none"> <li>• Electricity price = \$0.069/kWh (0.4 m<sup>3</sup> biogas)</li> <li>• Market value of N fertilizers = \$1.2/kg N</li> <li>• Market value of residual fuel oil (RFO) = \$0.014/MJ, the most common industrial fuel in Ghana</li> </ul>	<ul style="list-style-type: none"> <li>• For biogas yields see above</li> <li>• Electr. production: 0.4 m<sup>3</sup> biogas/kWh</li> <li>• Incremental yield = 2.84 t/ha compared to soil [98]</li> <li>• NA</li> </ul>	<ul style="list-style-type: none"> <li>• For anaerobic digesters see above</li> <li>• Generator = \$500/KW; operation = 24 hr</li> <li>• See dewatered FS as fuel</li> <li>• Sludge drying beds = \$10/m<sup>2</sup> [100]; Sludge retention = 14 d; Sludge depth = 0.2 m [101]</li> </ul>	<ul style="list-style-type: none"> <li>• For facility O&amp;M see above; additional O&amp;M of generator = 5% generator capital cost</li> <li>• Electricity price = \$0.069/kWh</li> <li>• See dewatered FS as fuel</li> <li>• Manager wage = \$900/mo, 1 manager</li> <li>• Drying beds O&amp;M -Sludge loading &amp; desludging = 0.5 man-hr/d/500 m<sup>2</sup> [100]</li> <li>-Laborer hrs = 8/d</li> <li>-Laborer wage = \$3.5/d</li> <li>• Transportation</li> <li>-Truck capacity = 20 t</li> <li>-Transport dist = 60 km/roundtrip</li> <li>-Diesel consumption = 0.168 kg/km</li> <li>-Cost of diesel = \$0.82/L (Ghana diesel market price as of 2010)</li> <li>-Driver = \$3.5/trip</li> <li>• Manger wage = \$900/mo, 2 managers</li> <li>• Drying bed O&amp;M see 'Dewatered FS as fuel'</li> <li>• storage facility; labor; manager</li> <li>• Compost system O&amp;M -SW sorting = 0.02 man-</li> </ul>
<p>Co-composted fecal sludge as soil conditioner</p>	<ul style="list-style-type: none"> <li>• 1 ha/14 ton mature compost (210 kg N/ha)</li> <li>• 1 application/yr</li> </ul>	<ul style="list-style-type: none"> <li>• Farmer willingness to pay in Ghana = \$0.075/kg</li> </ul>	<ul style="list-style-type: none"> <li>• Incremental yield = 1.7 t/ha compared to soil [98]</li> </ul>	<ul style="list-style-type: none"> <li>• Drying beds see 'Dewatered FS as fuel'</li> <li>• Composting infrastructure -Manual Windrows capital cost derived formula (Y=mx+b) from NESSAP (p 145 of 165) [102] where, Y = capital cost (\$), m = 5325.5, x = ln(compost production (t/d),</li> </ul>	

On-farm-treated wastewater for irrigation	<ul style="list-style-type: none"> <li>• 1 crop-cycle ha per 6667 m<sup>3</sup></li> <li>• 3 crop cycles/yr</li> </ul>	<ul style="list-style-type: none"> <li>• Water considered a free good</li> </ul>	<ul style="list-style-type: none"> <li>• Incremental value of additional dry season production compared to rainy season only Ghana = \$4300/ha.yr</li> </ul>	<p>b = 11914</p> <ul style="list-style-type: none"> <li>• Compost production (t/d) assumes solid waste (SW):FS = 3:1; 47 g total solids/pe.d @ 5% DS; 50% reduction when compost matures</li> </ul>	<ul style="list-style-type: none"> <li>• Transportation see 'Dewatered FS as fuel'</li> </ul>
Partially treated wastewater for aquaculture	<ul style="list-style-type: none"> <li>• Fish for 5-10,000 people at per capita consumption of 10-20 kg/yr (average range in sub-Saharan Africa)</li> </ul>	<ul style="list-style-type: none"> <li>• Water in WSPs (no assigned value)</li> </ul>	<ul style="list-style-type: none"> <li>• Production based on stocking density of 4 fish/m<sup>2</sup>; 65% survival; 2 cultivation seasons/year; market price = \$2.1/1 kg catfish; average weight 0.85 kg/catfish</li> </ul>	<ul style="list-style-type: none"> <li>• Improved settling ponds = \$17/0.03ha [103]</li> <li>• Waste stabilization ponds capital = \$30/pe [104]</li> <li>• Maturation pond sizing assumes 5 d retention time @ 1.5 m depth</li> <li>• Aquaculture equipment (e.g. net, boots) = \$1000</li> </ul>	<ul style="list-style-type: none"> <li>• Water fetching and application to decrease pathogen risk = \$25/0.03 ha [103]</li> <li>• WSP O&amp;M = \$1.5/pe.yr [104]</li> <li>• Aquaculture-specific: <ul style="list-style-type: none"> <li>-Fingerlings = \$0.2/catfish</li> <li>-Manager wage = \$900/mo</li> <li>-Labor = \$103/pe.mo; 0.2 laborer /ha fish ponds</li> <li>-Guard = \$140/mo; Guard requirement = 1/WSP system</li> <li>-Water/fish quality monitoring = \$150/sampling event, 6 sampling/cultivation period</li> </ul> </li> </ul>
Treated wastewater for irrigation	<ul style="list-style-type: none"> <li>• 1 crop-cycle ha/ 6667 m<sup>3</sup></li> <li>• 3 crop cycles/yr</li> </ul>	<ul style="list-style-type: none"> <li>• Market value of irrigation water = \$0.02/m<sup>3</sup> b</li> </ul>	<ul style="list-style-type: none"> <li>• Incremental yield compared to rainfed agriculture</li> </ul>	<ul style="list-style-type: none"> <li>• Waste stabilization ponds see 'Partially treated wastewater for aquaculture'</li> </ul>	<ul style="list-style-type: none"> <li>• See 'Partially treated wastewater for aquaculture'</li> </ul>

Source: Adapted from Murray et al. 2011.

## APPENDIX 2: LIST OF INTERVIEWS

NAME	AFFILIATION	EMAIL	PHONE
Peter Gichohi	Director, <i>Bio Power Systems Ltd.</i> ; Consultant to <i>Ministry of Energy</i>	biogassystems@yahoo.com	020 204 3435
Simon Munywe	Director, <i>Kayole Environmental Management Association</i>	info@kemakenya.org	073 397 2719
Samuel Okuche	Snr. Public Health Officer, <i>Ministry of Public Health and Sanitation</i>	samuelokuche@yahoo.com	072 355 9185
Ibrahim Longolomoi	Head Division of Occupational Health and Safety, <i>Ministry of Public Health and Sanitation</i>	ilongolomoi@yahoo.co.uk	072 247 9116
Josiah Omotto	<i>Umande Trust</i>	info@umande.org	072 356 0692
K.I. Muraya	Direct of Environment, <i>City Council of Nairobi</i>	imuraya@nairobi-city.go.ke	072 284 0131
J.P. Kimani	Engineer, <i>Nairobi City Water and Sewerage Company Ltd.</i>	jkimani@nairobiwater.co.ke	020 398 8530
Michael Kimenye Thiga	Lab Director, <i>Ruai Wastewater Treatment Plant</i>	mkimenya@nairobiwater.co.ke	072 224 2408
David Kuria	Director, <i>Ecotact</i>	kuria@ecotact.org	072 250 9242
Camilla Wirseen	Co-Director, <i>Peepoople</i>	cw@peepoople.com	
Henry Ndede	Coordinator, <i>UNEP-Kenya Country Program</i>	Henry.Ndede@unep.org	071 360 0953
Nancy Karanja	Professor, <i>Land Resource Management and Agricultural Technology, University of Nairobi</i>	nancy.karanja@cgiar.org	072 247 2667
Deborah Gathu Mbugua Mwangi	<i>Mazingira Institute</i> Directorate of Aquaculture, <i>Ministry of Fisheries Development</i>	deborahgathu@gmail.com	

## GLOSSARY

**Aerobic:** Living or taking place in the presence of oxygen.

**Anaerobic:** Living or taking place in the absence of oxygen.

**Aquaculture:** the practice of cultivating aquatic animals like fish or crustaceans.

**Belt filter press dewatering:** An apparatus that conveys sludge at a constant speed between two belts, whereby water drains through the pores of the lower belt.

**Biodiesel:** A substitute for fossil-derived diesel made by combining animal fat, vegetable oil, or fatty acids with alcohol. Biodiesel can be directly substituted for petroleum-diesel, or be used as an additive.

**Biogas:** The gas produced by anaerobic digestion systems. It comprises 60-80% methane, with the remainder being carbon dioxide (CO<sub>2</sub>) and trace gases.

**Calorific value:** The energy released as heat when a compound undergoes complete combustion with oxygen under standard conditions. The value is usually expressed as joules (or megajoules) per kilogram.

**Centrifuge dewatering:** A conical-cylinder decanter that turns horizontally on its axis using centrifugal force to accelerate solid-liquid separation.

**Cesspit emptier:** Large trucks, typically equipped with a vacuum mechanism, cargo tank and associated equipment for emptying and transporting the contents of pit latrines and septic tanks.

**Clinker:** a mixture of limestone, clay, and oxides, which is processed under high temperatures with gypsum in kilns to produce cement.

**Compost:** The soil-like product aerobic breakdown of organic matter, a process that is known as composting. The product can be used as a fertilizer and soil amendment. The speed and efficacy of composting is dependent upon carbon, nitrogen and moisture levels, and availability of oxygen.

**Co-compost:** Compost that is produced from more than one feedstock, e.g. the organic component of municipal solid waste and fecal sludge.

**Compressed natural gas (CNG):** Natural gas that has been highly compressed and stored in high-pressure cylinders. It is used as a substitute for gasoline, diesel, or propane, and is most commonly used for motor vehicles. It generates lower hydrocarbon emissions but high nitrogen oxide emissions.

**Dewatered:** A material that has had its water content reduced or removed. For example, dewatered fecal sludge is that which has undergone a process for removing a portion of the water content.

**Disability adjusted life year (DALY):** Public health metric of healthy life years lost to disease due to both morbidity and mortality, adjusted for disability.

**Dry ton:** Mass of a substance or material based on its solid content. It is a term applied to wet materials like sludge or slurries to distinguish between their mass with and without the water or liquid substrate.

**Drying bed:** An open-air system built for dewatering sludge, which relies on gravity percolation and evaporation.

**Ecological sanitation (ecosan):** Sanitation systems that facilitate resource recovery from human waste. The term is most often applied to household- or community-level systems that are designed, e.g. to separate urine and feces for use as fertilizer and for composting, respectively, or designed for biogas generation.

**Excreta:** feces and urine.



**Fecal sludge:** the solid or settled contents of pit latrine and septic tanks, i.e. on-site sanitation systems. The characteristics, including water content, pathogen load, and other physical, chemical, and biological qualities vary considerably based on the toilet and latrine type, as well as temperature, storage time, intrusion of groundwater, and performance of the septic tank. The solids content typically ranges from 5-20%.

**Lower heating value (LHV):** Otherwise defined as the net calorific value, it is the energy released during oxidation of a unit of fuel excluding the heat required for vaporization of the water in the fuel and the water produced from combustion of the fuel hydrogen. In other words, the LHV (in contrast to higher heating value) assumes that the latent heat of vaporization of water in the material is not recovered.

**Maturation pond:** The final pond(s) in a waste stabilization pond system, designed for tertiary treatment, in particular, pathogen removal.

**Mesophilic (anaerobic digestion):** Digestion taking place at ambient temperatures anywhere between 20 and 45° C. These operating conditions are the most common for anaerobic digestion because the bacteria are quite stable and tolerant of abrupt environmental changes.

**On-site sanitation:** Systems with combined collection and storage of excreta, and in some cases treatment. This contrasts with sewered systems where excreta is immediately transported away from the point of generation for treatment.

**Pathogens:** Disease-causing organisms.

**Saprophage:** An organism that feeds on dead or decaying organic matter.

**Sewage sludge:** the solids generated at wastewater treatment plants, such as those from settling tanks and aerobic processes. The solids content is typically 5%.

**Soil conditioner:** A chemical substance or composted material that is used to improve the structure or physical nature of soil.

**Stabilization:** A process whereby bacteria convert organic material into gases and other relatively inert substances.

**Struvite:** Common name for ammonium magnesium phosphate. The mineral is a naturally occurring crystal in stored urine; however, recovery is enhanced by the addition of magnesium, which is the limiting agent in natural struvite precipitation. Due to its high fertilizer value, it can be recovered and used in place of commercial phosphate fertilizers.

**Thermophilic (anaerobic digestion):** Digestion taking place at temperatures around 49-57 °C, and even up to 70 °C. These systems are typically less stable than mesophilic digestion and require external energy input. However, the increased temperatures facilitate faster reaction rates and thus faster gas yields. The higher temperatures yield better pathogen removal, which is particularly beneficial if the sludge is to be reused for agricultural purposes.

**Urine-diverting dry toilet (UDDT):**

**Waste stabilization ponds:** A series of constructed ponds designed to treat wastewater. A typical system comprises anaerobic, facultative, and maturation ponds. These systems are the most common type of natural treatment plant, and they are attractive because of their low capital and operation and maintenance costs, and their high performance.

**Wet ton:** The mass of a substance or material that includes the water content along with the solids or dry component.

## LITERATURE CITED

1. Valfrey-Visser, B., Hydroconseil, and D. Schaub-Jones, *Engaging sanitation entrepreneurs: supporting private entrepreneurs to deliver public goods* 2008, Building Partnerships for Development.
2. Murray, A. and I. Ray, *Back-End Users: The Unrecognized Stakeholders in Demand-Driven Sanitation*. Journal of Planning Education and Research, 2010. **30**(1): p. 94-102.
3. Murray, A., O. Cofie, and P. Drechsel, *Efficiency Indicators for Waste-Based Business Models: Fostering Private Sector Participation in Wastewater and Fecal Sludge Management*. Water International, (In press).
4. Water and Sanitation Program, *Performance Improvement Planning: Developing Effective Billing and Collection Practices*. 2008, Water and Sanitation Program, World Bank: New Delhi, India.
5. Global Sanitation Fund and Water Supply & Sanitation Collaborative Council, *Sanitation Sector Status and Gap Analysis: Kenya*. 2009.
6. Kone, D., *Making urban excreta and wastewater management contribute to cities' economic development: a paradigm shift*. Water Policy, 2010. **12**: p. 602-610.
7. Ministry of Water and Irrigation, *Implementation Plan for Sanitation (The Water Sector Sanitation Concept)*. 2009, Ministry of Water and Irrigation, Republic of Kenya: Nairobi.
8. Ministry of Health, *National Environmental Sanitation and Hygiene Policy*. 2007, Ministry of Health, Republic of Kenya: Nairobi.
9. Asano, T. and A. Levine, *Wastewater recalculation, recycling and reuse: past, present, and future*. Water Science and Technology, 1996. **33**(10-11): p. 1-14.
10. Environmental Protection Agency., *Biosolids Generation, Use, and Disposal in the United States*, S.W.a.E.R. Office, Editor. 1999, US Environmental Protection Agency: Washington D.C. p. 81.
11. Murray, A., O. Cofie, and P. Drechsel, *Efficiency indicators for waste-based business models: fostering private-sector participation in wastewater and faecal-sludge management*. Water International, 2011. **36**(4): p. 505-520.
12. Gajurel, D.R., Z. Li, and R. Otterpohl, *Investigation of the effectiveness of source control sanitation concepts including pre-treatment with Rottebehalter*. Water Science & Technology, 2003. **48**(1): p. 111-118.
13. Etter, B., *Struvite recovery from urine at community scale in Nepal: Project intermediate report submitted to EPFL*, in *Environmental Sciences and Engineering*. 2009, Swiss Federal Institute of Technology Lausanne: Kathmandu, Nepal.
14. Gantenbein, B. and R. Khadka, *Community recovery from urine at community scale in Nepal: Final project report Phase I*. 2009, Eawag: Dubendorf, Switzerland and Kathmandu, Nepal.
15. Adamtey, N., et al., *Production and storage of N-enriched co-compost*. Waste Management, 2009. **29**(9): p. 2429-2436.
16. Adamtey, N., et al., *Effect of N-enriched co-compost on transpiration efficiency and water-use efficiency of maize (Zea mays L.) under controlled irrigation*. Agricultural Water Management, 2010. **97**: p. 995-1005.
17. Nkansah, F., *Socio-cultural and economic factors influencing faecal sludge use in agriculture in the Manya Krobo district*, in *Department of Civil Engineering*. 2006, Kwame Nkrumah University of Science and Technology: Kumasi.
18. Wang, M.-J., *Land Application of Sewage Sludge in China*. the Science of the Total Environment, 1997. **197**: p. 149-160.
19. EAWAG-SANDEC, *Solids separation and pond systems for the treatment of faecal sludges in the tropics: lessons learnt and recommendations for preliminary design*. 1998, EAWAG/SANDEC: Duebendorf, Switzerland. p. 88.

20. Diener, S., C. Zurbrugg, and K. Tockner, *Conversion of organic material by black soldier fly larvae: establishing optimal feeding rates*. Waste Management & Research, 2009. **27**(6): p. 603.
21. Nguyen, D., *Decomposition of organic wastes and fecal sludge by black soldier fly larvae*, in *Environmental Engineering and Management*. 2010, Asian Institute of Technology: Bangkok.
22. Newton, L., et al., *Using the black soldier fly, Hermetia illucens, as a value-added tool for the management of swine manure*. Univ. Of Georgia, College of Agric. & Environ. Sci., Dept. Of Anim. & Dairy Sci. Annual Report, 2004.
23. Diener, S., et al. *Black Soldier Fly larvae for organic waste treatment - prospects and constraints in WasteSafe 2011: Solid Waste Management in the Developing Countries*. 2011. Khulna, Bangladesh.
24. Dang, N., *Decomposition of organic wastes and fecal sludge by black soldier fly larvae*, in *Environmental Engineering and Management*. 2010, Asian Institute of Technology: Bangkok.
25. Sheppard, C., et al., *Rearing methods for the black soldier fly (Diptera: Stratiomyidae)*. Journal of medical entomology, 2002. **39**(4): p. 695-698.
26. Index Mundi. *Fishmeal monthly price*. 2011 April 25, 2011]; Available from: <http://www.indexmundi.com/commodities/?commodity=fish-meal&months=120>.
27. Newton, L., et al., *Using the black soldier fly, Hermetia illucens, as a value-added tool for the management of swine manure*. Univ. Of Georgia, College of Agric. & Environ. Sci., Dept. Of Anim. & Dairy Sci. Annual Report, 2005.
28. Bolzonella, D., Innocenti, L., Cecchi, F., *Biological nutrient removal wastewater treatment and sewage sludge anaerobic mesophilic digestion performance*. Water Science and Technology, 2002. **46**(10): p. 199-208.
29. Lansing, S., R.B. Botero, and J.F. Martin, *Waste treatment and biogas quality in small-scale agricultural digesters*. Bioresources Technology, 2008. **99**: p. 5881-5890.
30. Lohri, C., et al. *Evaluation of Biogas Sanitation Systems in Nepalese Prisons*. in *IWA-DEWATS Conference 2010, Decentralized Wastewater Treatment Solutions in Developing Countries*. 23-26 March 2010. Surabaya, Indonesia.
31. Vijay, V.K., et al. *Biogas Purification and Bottling into CNG Cylinders: Producing Bio-CNG from Biomass for Rural Automotive Applications*. 2006.
32. Vijay, V. *Biogas purification using water scrubbing systems*. in *Training Course on Biogas Production, Purification and Power Generation for Commercial Technology Packages*. 25-29 October 2010. IIT-Delhi.
33. Govil, G.P. *Small biogas engine conversion kit in Training Course on Biogas Production, Purification and Power Generation for Commercial Technology Packages*. 25-29 October 2010. IIT-Delhi.
34. NIIR Board, *Handbook on Biogas and Its Applications*, Delhi: National Institute of Industrial Research.
35. International Association for Natural Gas Vehicles. *Natural Gas Vehicles - Regional Growth*. 2009 August 5, 2010]; Available from: [http://www.iangv.org/stats/NGV\\_Statistics09.htm](http://www.iangv.org/stats/NGV_Statistics09.htm).
36. Fytali, D., Zabaniotou, A., *Utilization of sewage sludge in EU application of old and new methods - a review*. Renewable and Sustainable Energy Review, 2006. **Article in Press**.
37. Murray, A., A. Horvath, and K. Nelson, *Hybrid Life-Cycle Environmental and Cost Inventory of Sewage Sludge Treatment and End-Use Scenarios: A Case Study from China*. Environmental Science & Technology, 2008. **42**: p. 3163-3169.
38. Vallet, F., *Lower heating value of sludge in Chongqing, Sichuan Province, China*, A. Murray, Editor. 2007: Chongqing, Sichuan Province, China.
39. EPA, *Estimating Sludge Management Costs*. 1985, Cincinnati, OH: Environmental Protection Agency.
40. SNF Floerger, *Sludge Dewatering*. 2003, SNF Floerger: France.

41. Stasta, P., Boran, J., Bebar, L., Stehlik, P., Oral, J., *Thermal processing of sewage sludge*. Applied Thermal Engineering, 2006. **26**: p. 1420-1426.
42. Wilson, T., Yang, X., Howard, J., Shen, C.W., *Beijing Sludge/Biosolids Master Plan*, T.C.I.o.W.a.E. Management, Editor. 2006, Earth Tech: London. p. 18.
43. EAWAG/SANDEC, *Solids separation and pond systems for the treatment of faecal sludged in the tropics: lessons learnt and recommendations for preliminary design*. 1998, EAWAG/SANDEC: Duebendorf, Switzerland.
44. Hospido, A., et al., *Environmental evaluation of different treatment processes for sludge from urban wastewater treatments: Anaerobic digestion versus thermal processes*. International Journal of Life Cycle Assessment, 2005. **10**(5): p. 336-345.
45. Brick, S., *Biochar: Assessing the Promise and Risks To Guide U.S. Policy*, in *NRDC Issue Paper*. November 2010, Natural Resource Defense Council.
46. Libra, J., et al., *Hydrothermal carbonization of biomass residuals: a comparative review of the chemistry, processes and applications of wet and dry pyrolysis*. Biofuels, 2011. **2**(1): p. 89-124.
47. Titirici, M.M., A. Thomas, and M. Antonietti, *Back in the black: hydrothermal carbonization of plant material as an efficient chemical process to treat the CO<sub>2</sub> problem?* New Journal of Chemistry, 2007. **31**(6): p. 787-789.
48. Leung, D., X. Wu, and M. Leung, *A review on biodiesel production using catalyzed transesterification*. Applied Energy, 2010. **87**(4): p. 1083-1095.
49. Mondala, A., et al., *Biodiesel production by in situ transesterification of municipal primary and secondary sludges*. Bioresource Technology, 2009. **100**(3): p. 1203-1210.
50. Demirbas, A., *Biofuels sources, biofuel policy, biofuel economy and global biofuel projections*. Energy Conversion and Management, 2008. **49**(8): p. 2106-2116.
51. Kargbo, D.M., *Biodiesel Production from Municipal Sewage Sludges*. Energy & Fuels, 2010. **24**(5): p. 2791-2794.
52. Revellame, E., et al., *Biodiesel from activated sludge through in situ transesterification*. Journal of Chemical Technology & Biotechnology, 2010. **85**(5): p. 614-620.
53. El-Shafai, S.A., et al., *Microbial quality of tilapia reared in fecal-contaminated ponds*. Environmental Research, 2004. **95**(2): p. 231-238.
54. WHO, *WHO Guidelines for the Safe Reuse of Wastewater, Excreta and Greywater, Vol III: Wastewater and Excreta Use in Aquaculture*. 2006, World Health Organization: Geneva. p. 162.
55. Jana, B.B., *Sewage-fed aquaculture: The Calcutta model*. Ecological Engineering, 1998. **11**(1-4): p. 73-85.
56. Zwirn, M., *Aquaculture in Egypt: Improving Food Security and Resolving Resource Allocation Conflicts*. The Journal of Environment Development, 2002. **11**(2): p. 129-148.
57. UNEP International Environmental Technology Centre and Murdoch University Environmental Technology Centre, *International Source Book on Environmentally Sound Technologies for Wastewater and Stormwater Management*. IETC-UNEP, Technical Publication. 2002, London: IWA.
58. Guterstam, B., et al., *Stensund wastewater aquaculture: Studies of key factors for its optimization*. Ecological Engineering, 1998. **11**(1-4): p. 87-100.
59. WHO, *Guidelines for the Safe Use of Wastewater, Excreta and Greywater, Volume 3: Wastewater and excreta use in aquaculture*. 2006b, World Health Organization: Geneva.
60. Raschid-Sally, L., Carr, R., Buechler, S., *MANAGING WASTEWATER AGRICULTURE TO IMPROVE LIVELIHOODS AND ENVIRONMENTAL QUALITY IN POOR COUNTRIES*. Irrigation and Drainage, 2005. **54**: p. S11-S22.
61. WHO, *WHO Guidelines for the Safe Use of Wastewater, Excreta and Greywater, Vol II: Wastewater Use in Agriculture*. 2006, World Health Organization p. 222.

62. Jimenez, B., Asano, T., *Water Reclamation and Reuse Around the World*, in *Water Reuse: an International Survey: Common Practices and Current Needs in the World*, B. Jimenez, Asano, T., Editor. 2008, IWA Publishing: London. p. 3-26.
63. Mohammad, M.J., Ayadi, M., *Forage Yield and Nutrient Uptake as Influenced by Secondary Treated Wastewater*. Journal of Plant Nutrition, 2005. **27**(2): p. 351-365.
64. Asano, T., Levine, A., *Wastewater reclamation, recycling and reuse: past, present, and future*. Water Science & Technology, 1996. **33**(10-11): p. 1-14.
65. US EPA, *Guidelines for Water Reuse*. 2004, Municipal Support Division, Office of Wastewater Management, US Environmental Protection Agency: Washington, DC.
66. Al-Nakshabandi, G., Saqqar, M., Shatanawi, M., *Some environmental problems associated with the use of treated wastewater for irrigation in Jordan*. Agricultural Water Management, 1997. **34**: p. 81-94.
67. Lopez, A., et al., *Agricultural wastewater reuse in southern Italy*. Desalination Integrated Concepts in Water Recycling, 2006. **187**(1-3): p. 323-334.
68. Kiziloglu, M., Turan, M., Sahin, U., Angin, I., Anapali, O., Okuroglu, M., *Effects of wastewater irrigation on soil and cabbage-plant (*brassica oleracea* var. capitata cv. yalova-1) chemical properties*. Journal of Plant Nutrition and Soil Science, 2007. **170**(1): p. 166-172.
69. Strauss, M., *Human Waste (Excreta and Wastewater) Reuse*, in *Bibliography on Urban Agriculture*. 2000, EAWAG/SANDEC: Duebendorf, Switzerland.
70. Frans P. Huibers, J.B.V.L., *Use of wastewater in agriculture: the water chain approach*. Irrigation and Drainage, 2005. **54**(S1): p. S3-S9.
71. Ernst-Jan Martijn, M.R., *Wastewater irrigation in developing countries - limitations for farmers to adopt appropriate practices*. Irrigation and Drainage, 2005. **54**(S1): p. S63-S70.
72. Friedel, J.K., et al., *Effects of long-term waste water irrigation on soil organic matter, soil microbial biomass and its activities in central Mexico*. Biology and Fertility of Soils, 2000. **31**(5): p. 414-421.
73. Bradford, A., Brook, R., Hunshal, C., *Wastewater irrigation in HUBLI-Dharwad, India: implication for health and livelihoods environment and Urbanization*, 2003. **15**: p. 157-172.
74. Velez, O., Fasciolo, G., Bertranou, A., *Domestic wastewater treatment in waste stabilization ponds for irrigation in Mendoza, Argentina: policies and challenges*. Water Science & Technology, 2002. **45**(1): p. 127-132.
75. Rosenqvist, H., et al., *Economics of using municipal wastewater irrigation of willow coppice crops*. Biomass and Bioenergy, 1997. **12**(1): p. 1-8.
76. Environmental and Process Systems Engineering Group and National Task Team, *Integrated Solid Waste Management Plan for the City of Nairobi, Kenya*, H.v. Blotnitz, Editor. 2010, UNEP: Nairobi.
77. Prain, G., N. Karanja, and D. Lee-Smith, *African Urban Harvest: Agriculture in the Cities of Cameroon, Kenya and Uganda*. 2010: Springer.
78. Peter Gichohi Director of Bio Power Systems Ltd, *Interview on biogas potential in Kenya*, personal communication with A. Murray, Editor. May 6, 2011: Nairobi, Kenya.
79. Bruvold, W. *Obtaining public support for innovative reuse projects*. in *Water Reuse Symposium 3*. 1984. San Diego, CA.
80. The FishSite, *Kenya Leads Aquaculture in East Africa*, in [www.thefishsite.com](http://www.thefishsite.com). December 21, 2010, 5M Enterprisers Ltd.
81. Mbugua Mwangi - Directorate of Aquaculture, *State of aquaculture in Kenya*, personal communication with A. Murray, Editor. May 11, 2011: Nairobi, Kenya.
82. Ngugi, C., J. Bowman, and B. Omolo, *A New Guide to Fish Farming in Kenya*. 2007, USAID and Aquaculture CRSP.

83. Gakubia, R., U. Pokorski, and P. Onyango, *Upsaling Access to Sanitation*, in *Follow-up Conference of the International Year of Sanitation*. 2010: Tokyo, Japan.
84. Neira, I., Engle, C., Ngugi, C., *Economic and risk analysis of Tilapia production in Kenya*. Journal of Applied Aquaculture, 2010. **21**: p. 73-95.
85. Barasa, L., *Kenya workers get pay boost*, in *Daily Nation*. 2009.
86. Nandeesh, M., *Sewage Fed Aquaculture Systems of Kolkata a Century Old Innovation of Farmers*. Aquaculture Asia, 2002. **7**: p. 28-32.
87. Wanzala, M., et al., *Fertilizer markets and agricultural production incentives: Insights from Kenya*. A paper prepared in a joint collaboration with Tegemeo Agricultural Monitoring and Policy Analysis (TAMPA) Project, Egerton University/Michigan State University with the support by the United States Agency for International Development/Kenya, 2001.
88. TradingEconomics. *Fertilizer Consumption (Metric Tons) in Kenya*. 2011 May 25, 2011]; Available from: <http://www.tradingeconomics.com/kenya/fertilizer-consumption-metric-tons-wb-data.html>.
89. Kinyanjui, H., et al., *Stakeholder perceptions of agriculture policies in Kenya*, in *Managing Africa's Soils No. 18*. 2000, IIED: London.
90. Duflo, E., M. Kremer, and J. Robinson, *Nudging farmers to use fertilizer: theory and experimental evidence from Kenya*. 2009, National Bureau of Economic Research Cambridge, Mass., USA.
91. Nancy Karanja - Professor University of Nairobi, *Potential for waste-based fertilizers in Kenya*, personal communication with A. Murray, Editor. May 12, 2011: Nairobi, Kenya.
92. Langergraber, G., Muellegger, E., *Ecological Sanitation—a way to solve global sanitation problems?* Environment International, 2005. **31**: p. 433-444.
93. Germer, J., S. Addai, and D. Sarpong, *Fertilization with human urine...in a nutshell*. 2009, University of Hohenheim, Berger Biotechnik, Valley View University.
94. Germer, J. and J. Sauerborn, *Exploring the Potential for Recycling Nutrients to Enhance Agricultural Productivity - The Example of Valley View University in Accra, Ghana*. 2006, Sustainable Sanitation Alliance (<http://www.susana.org>).
95. Fall, A., *Urban urine diversion dehydration toilets and reuse, Ouagadougou, Burkina Faso*, in *Case study of SuSanA projects*. 2009, Sustainable Sanitation Alliance.
96. Schroder, E., *Marketing Human Excreta: A study of possible ways to dispose of urine and faeces from slum settlements in Kampala, Uganda*. 2010, GTZ.
97. Cofie, O., et al., *Farmers perception and economic benefits of excreta use in southern Ghana*. Resources, Conservation and Recycling, 2010. **55**(2): p. 161-166.
98. Adamtey, N., *Nitrogen enrichment of recycled organic waste for peri-urban maize (Zea mays L.) cultivation and its effects on the soil environment*, in *School of Research and Graduate Studies, Faculty of Science*. Submitted 2010, University of Ghana, Legon: Accra.
99. SNV, *Building Viable Domestic Biogas Programmes: Success Factors in Sector Development*. 2009, The Netherlands Development Organisation.
100. Zurbrugg, C., et al., *Co-treatment of faecal sludge and organic municipal solid waste by composting: An economic appraisal*. Unpublished manuscript.
101. Cofie, O. and D. Kone, *Co-composting of faecal sludge & organic solid waste: Kumasi, Ghana*. 2009, Sustainable Sanitation Alliance.
102. MLGRD and EHSD, *National Environmental Sanitation Strategy and Action Plan: Materials in Transition*. 2010, Ministry of Local Government and Rural Development and Environmental Health and Sanitation Directorate, Government of Ghana: Accra.
103. Seidu, R. and P. Drechsel, *Cost effectiveness analysis of interventions for diarrhoea disease reduction among consumers of wastewater-irrigated lettuce in Ghana*, in *Wastewater Irrigation*

- and Health: Assessing and Mitigation Risks in Low-Income Countries*, P. Drechsel, et al., Editors. 2010, Earthscan-IDRC-IWMI: UK.
104. von Sperling, M. and C. Augusto de Lemos Chernicharo, *Biological Wastewater Treatment in Warm Climate Regions*. 2005, London: IWA Publications.