



WATER FROM SAND RIVERS

A manual on site survey, design, construction and maintenance of seven types of water structures in riverbeds



Erik Nissen-Petersen



RELMA

WATER FROM SAND RIVERS

A manual on site survey, design,
construction, and maintenance of
seven types of water structures
in riverbeds

RELMA Technical Handbook Series no. 23

The Technical Handbook Series of the Regional Land Management Unit

1. *Curriculum for In-service Training in Agroforestry and Related Subjects in Kenya*. Edited by Stachys N. Muturi, 1992 (ISBN 9966-896-03-1)
2. *Agroforestry Manual for Extension Workers with Emphasis on Small-Scale Farmers in Eastern Province, Zambia*. By Samuel Simute, 1992 (ISBN 9966-896-07-4)
3. *Guidelines on Agroforestry Extension Planning in Kenya*. By Bo Tengnäs, 1993 (ISBN 9966-896-11-2)
4. *Agroforestry Manual for Extension Workers in Southern Province, Zambia*. By Jericho Mulofwa with Samuel Simute and Bo Tengnäs, 1994 (ISBN 9966-896-14-7)
5. *Useful Trees and Shrubs for Ethiopia: Identification, Propagation and Management for Agricultural and Pastoral Communities*. By Azene Bekele-Tessema with Anne Birnie and Bo Tengnäs, 1993 (ISBN 9966-896-15-5)
6. *Useful Trees and Shrubs for Tanzania: Identification, Propagation and Management for Agricultural and Pastoral Communities*. By L.P. Mbuya, H.P. Msanga, C.K. Rufo, Ann Birnie and Bo Tengnäs, 1994 (ISBN 9966-896-16-3)
7. *Soil Conservation in Arusha Region, Tanzania: Manual for Extension Workers with Emphasis on Small-Scale Farmers*. By Per Assmo with Arne Eriksson, 1994 (ISBN 9966-896-19-8)
8. *Curriculum for Training in Soil and Water Conservation in Kenya*. Edited by Stachys N. Muturi and Fabian S. Muya, 1994 (ISBN 9966-896-20-1)
9. *The Soils of Ethiopia: Annotated Bibliography*. By Berhanu Debele, 1994 (ISBN 9966-896-21-X)
10. *Useful Trees and Shrubs for Uganda: Identification, Propagation and Management for Agricultural and Pastoral Communities*. By A.B. Katende, Ann Birnie and Bo Tengnäs, 1995 (ISBN 9966-896-22-8)
11. *Agroforestry Extension Manual for Northern Zambia*. By Henry Chilufya and Bo Tengnäs, 1996 (ISBN 9966-896-23-6)
12. *Useful Trees and Shrubs in Eritrea: Identification, Propagation and Management for Agricultural and Pastoral Communities*. By E. Bein, B. Habte, A. Jaber, Ann Birnie and Bo Tengnäs, 1996 (ISBN 9966-896-24-4)
13. *Facilitators' Manual for Communication Skills Workshop*. By Pamela Baxter, 1996 (ISBN 9966-896-25-2)
14. *Agroforestry Extension Manual for Extension Workers in Central and Lusaka Provinces, Zambia*. By Joseph Banda, Penias Banda and Bo Tengnäs, 1997 (ISBN 9966-896-31-7)
15. *Integrated Soil Fertility Management on Small-Scale Farms in Eastern Province of Zambia*. Edited by Thomas Raussen, 1997 (ISBN 9966-896-32-5)
16. *Water Harvesting: An illustrative Manual for Development of Microcatchment Techniques for Crop Production in Dry Areas*. By M.T. Hai, 1998 (ISBN 9966-896-33-3)
17. *Agroforestry Extension Manual for Eastern Zambia*. By Samuel Simute, C.L. Phiri and Bo Tengnäs, 1998 (ISBN 9966-896-36-8)
18. *Banana Production in Uganda: An Essential Food and Cash Crop*. By Aloysius Karugaba with Gathiru Kimaru, 1999 (ISBN 9966-896-39-2)
19. *Wild Food and Mushrooms of Uganda*. By Anthony B. Katende, Paul Ssegawa, Ann Birnie with Christine Holding and Bo Tengnäs, 1999 (ISBN 9966-896-39-2)
20. *Uganda Land Resources Manual: A Guide for Extension Workers*. By Charles Rusoke, Antony Nyakuni, Sandra Mwebaze, John Okorio, Frank Akena and Gathiru Kimaru, 2000 (ISBN 9966-896-44-9)
21. *Agroforestry Handbook for the Banana-Coffee Zone of Uganda: Farmers' Practices and Experiences*. By I. Oluka-Akileng, J. Francis Esegu, Alice A. Kaudia and Alex Lwakuba, 2000 (ISBN 9966-896-51-1)
22. *Rainwater Harvesting for Natural Resource Management: A planning guide for Tanzania*. Edited by Nuhu Hatibu, Henry F. Mahoo; Contributors John W. Gowing, Geophrey J. Kajiru, Evelyn A. Lazaro, Omari B. Mzirai, Johan Rockström, Filbert B. Rwehumbiza, Ephraim M. Senkondo, 2000 (ISBN 9966-896-52-X)

WATER FROM SAND RIVERS

A manual on site survey, design,
construction, and maintenance of
seven types of water structures
in riverbeds

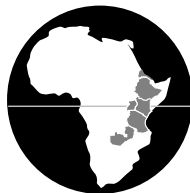

RELMA

Published by:

Regional Land Management Unit, RELMA/Sida, ICRAF House, Gigiri
P. O. Box 63403, Nairobi, Kenya.

© Regional Land Management Unit (RELMA), Swedish International Development Cooperation Agency (Sida)

The contents of this manual may be reproduced without special permission. However, acknowledgment of the source is requested. Views expressed in the RELMA series of publications are those of the authors and do not necessarily reflect the views of RELMA/Sida.

Front cover photographs by:

Erik Nissen-Petersen

Illustrations by:

Erik Nissen-Petersen

Top: Storm water flowing through a seasonal river

middle: Community participation in the construction of a sand dam

Bottom: A sand dam constructed across a seasonal riverbed

Design and layout except front and back cover by:

Logitech Limited

P. O. Box 79177

Nairobi

Editing by:

Laser Consult Limited

P. O. Box 26456

Nairobi

Editor of RELMA series of publications:

Alex Oduor/RELMA

Cataloguing-in-Publication Data:

Water from Sand Rivers: A manual on site survey, design, construction, and maintenance of seven types of water structures in riverbeds. Erik Nissen-Petersen, Nairobi: Regional Land Management Unit (RELMA), Swedish International Development Cooperation Agency (Sida), 2000. (RELMA Technical Handbook Series ;23).

Bibliography: p

ISBN 9966-896-53-8

Printed by:

Colourprint Ltd

P.O. Box 44466

Nairobi

TABLE OF CONTENTS

PREFACE	vi
ACKNOWLEDGEMENTS	vii
TECHNICAL TERMS USED IN THE MANUAL	viii
FINANCIAL TERMS USED IN THE MANUAL	viii
INTRODUCTION	1
1.1 What is a sand river?	1
1.2 History of sand river development	1
1.3 Benefits of extracting water from sand rivers	2
1.4 Constraints and recommendations	3
2 SURVEY OF SAND RIVERS	6
2.1 Flooding of sand rivers	6
2.2 Floodwater trapped by underground dykes	6
2.3 Identifying underground water reservoirs	7
2.4 Tools and equipment for surveying sand rivers	8
2.5 Water-indicating vegetation	8
2.6 Depth of roots of water indicating trees	9
2.7 Dowsing	9
2.8 Probing	10
2.9 Probing records	12
2.10 Gradient of riverbeds	13
2.11 Trial pits / augering	13
2.12 Porosity and extractability of water from sand	13
2.13 Estimating the extractable volume of water from a sand reservoir	15
2.14 Extractable volume of water from sand reservoirs	16
2.15 Identifying suitable sand rivers	17
2.16 Sand dams in gullies	18
3 STRUCTURES FOR EXTRACTING WATER FROM SAND-RIVERS	19
3.1 Waterholes	19
3.2 Deep hand-dug wells	19
3.3 Intake pipe with a well shaft in the riverbank	20
3.4 Intake chamber with elevated water tank	21
4 INCREASING YIELD OF WATER FROM SAND RESERVOIRS	23
4.1 Subsurface dams built of soil	23
4.2 Subsurface dams built of rubble masonry or concrete	24
4.3 Sand dams built of rubble stone masonry or concrete	26
4.4 Flow chart on selecting connect type of structure	28
5 DESIGNS, BILLS OF QUANTITIES, COST AND PROCEDURES	29
5.1 A sinking hand-dug well with a hydro-dynamic well-head	29
5.2 An intake-pipe with a well shaft in a river-bank	36
5.3 An intake chamber with an elevated water tank	38
5.4 A subsurface dam built of soil	42
5.5 A subsurface dam built of rubble stone masonry	45
5.6 A sand dam built of rubble masonry	48
6 CONSTRUCTION PROCEDURES	53
6.1 Mixing of mortar	53
6.2 Mixing of concrete	54
6.3 Purchase of construction materials	55
6.5 Hiring a contractor	55
7 REFERENCES	57

PREFACE

This manual is intended for technicians, builders, trainers, students and development agencies dealing with site survey, design, construction and maintenance of:

- Hand-dug wells in deep sand,
- River-intakes with shaft in riverbank,
- Intake chambers with elevated water tank,
- Subsurface dams built of soil,
- Subsurface dams built of rubble stone masonry and
- Sand dams built of rubble stone masonry.

The manual is the first of a series of manuals covering:

- Water from sand rivers,
- Water from rock outcrops,
- Water from roads and compounds,
- Water from ponds and earth dams and
- Water from roofs.

The aim of these manuals is to present technical data on the development of affordable water sources in a comprehensive form which can be understood and applied by both designers and builders alike.

The structures described have a few things in common; they are built using simple techniques and are cheaper to construct and maintain than conventional water supply systems such as boreholes and reticulated piped water supply systems.

The manuals are based on 25 years of experience with practical work on designing, constructing and repairing various types of water supply systems in Africa and Asia. A few of the structures described here were adapted from structures built almost a hundred years ago, while others were invented and tested within recent years.

As time goes on, new improvements will develop in construction techniques and cost-reducing procedures. Readers are kindly requested to share their experience with the author such that improvements can be included in future editions.

Åke Barklund
Director, RELMA

ACKNOWLEDGEMENTS

Much gratitude is due to Mr Rolf Winberg, Water and Sanitation Adviser of the Regional Land Management Unit (RELMA). RELMA is a Sida-supported programme working in six African countries.

Many thanks are also due to the following persons who assisted with editing: namely Prof. Donald B. Thomas formerly of Nairobi University, Mr Eric Fewster of MEDAIR in Turkana, Mr Stephen Burgess, Engineer of ACK Eldoret Region Company Ltd., Mr Michael Otieno, District Water Engineer of Narok and Mr Patrick Omala and Mr Eric Njage of ASAL Consultants Ltd.

Special thanks go to the hundreds of engineers, technicians and builders in several countries who have worked together with me on the development of sand rivers during the last 25 years.

Erik Nissen-Petersen
ASAL Consultants Ltd.
P. O. Box 39263, Nairobi, Kenya.
Email asalcon@nbnet.co.ke

TECHNICAL TERMS USED IN THE MANUAL

ASALCON	ASAL Consultants Ltd.
BQ	Bill of Quantity.
Catchment	An area draining rainwater.
Draw-off pipe	Pipe extracting water from a reservoir.
Underground dyke	River floor protruding upwards.
Flash-floods	Flooding by rainwater run-off.
Infiltration pipe	Pipe through which water infiltrate.
Key	An underground extension preventing seepage.
Maximum flood level	The highest water level during floods.
River banks	The two sides of a sand river.
Riverbed	The area between the river banks.
River floor	The base under the sand in a riverbed.
Run-off	Rainwater running off a surface.
Spillway	Overflow for surplus water from a dam.
Subsurface	Below the surface.
Throw-back	Length of a water reservoir from dam wall.
Wing-walls	Extensions of a dam wall into riverbanks.

FINANCIAL TERMS USED IN THE MANUAL

Ksh	Kenyan Shillings.
Ksh 70/US\$ 1.00	
Value of community work	depends on local cost of labour and materials.

INTRODUCTION

1.1 What is a sand river ?

Definition of sand rivers

Sand rivers, also called dry riverbeds, luggas or wadis, are ephemeral (seasonal) watercourses containing sand, which are flooded with rainwater run-off from higher elevated catchment areas once or a few times in a year.



Plate 1: *A sand river*

1.2 History of sand river development

Water has been extracted from waterholes in sand rivers from time immemorial. The damming of water in sand rivers took place in Sardinia and North Africa some 2,000 years ago and in Arizona in the 1700s (Nilsson, 1988).

Subsurface dams built of soil were constructed by the Tanganyika Railway to provide water for their steam locomotives around 1900. The Bihawana Mission and others later replicated these near Dodoma in Tanzania. Sand dams were also built in Namibia, formerly known as South West Africa, by Wipplinger in the 1950s.

More than a hundred sand dams were built by various projects in Machakos and Kitui, with the most notable contributions being;

- Classen, of African Land Development (ALDEV) in the 1950s,
- Machakos Integrated Development Project (MIDP) in the 1980s funded by the European Economic Community
- Kitui ASAL programme in the 1980s, also built subsurface dams

- The Green Valley Project in the 1970s funded by Danida, Danish International Development Agency in Machakos, and
- Mutomo Soil & Water Conservation Project in the 1980s also funded by Danida.

Since 1990, the author has conducted many training courses on sand river development in Kenya, Tanzania and Burma.

The feasibility of constructing subsurface and sand dams in the semi-desert of Turkana in Kenya was studied by NORCONSULT in 1980. In the course of the year 2000, Mr. Eric Fewster and Dr. Frauke de Weijer built subsurface dams of soil on trial basis at Lockichogio and Lodwar respectively.

1.3 Benefits of extracting water from sand rivers

Storage and extraction of water from the voids between sand particles in sand rivers have the following benefits:

Evaporation

This is confined to the upper layer of sand reservoirs. As the water level sinks, evaporation is reduced accordingly and due to the lack of capillary action, stops when the water level sinks to about 60 cm below the sand surface. Reduced evaporation loss is a major advantage in hot and arid climates.

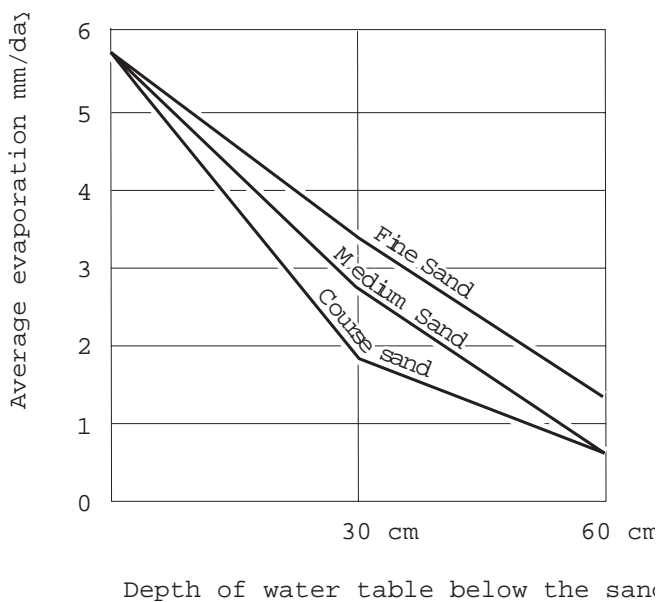

Figure 1: *Evaporation as a function of depth of water table.*

(Nilsson, 1988, quoting Hellwig, 1973).

This usually occurs only from sand reservoirs, which overlay fractured rocks or boulders. Such places should therefore be avoided when selecting new construction sites.

Siltation

Siltation does not create any problems because flash floods pass over sand reservoirs that are already full of sand. Topsoil particles and debris are cleared off during flooding. This is of particular benefit in eroded lands where open earth dams silt up quickly.

Contamination

Contamination of the water by insects, birds and animals cannot take place because the water is not exposed. Pollution by people and livestock can be avoided if water activities such as washing clothes or bathing take place on the downstream part of the dam wall, or on the riverbanks. Due to the lack of exposed water, mosquitoes cannot breed and spread malaria, bilharzia-carrying snails cannot survive and other water-borne diseases are also reduced dramatically.

Downstream flow of water

This is not affected because sand reservoirs are only recharged during floods, when water is plentiful everywhere. People living downstream will therefore not be deprived of water. The natural underground dyke would, in any case, also naturally hold the water from progressing downstream.

Recharge of sand reservoirs

This takes place when rains flood the sand river. Sand rivers with large or hard runoff catchments such as roads or rock outcrops, can produce sufficient runoff from about 10 mm of rain per hour to recharge water reservoirs in sand rivers.

1.4 Constraints and recommendations

Unfortunately, quite a number of sand dams have been built which are not functioning due to the wrong selection of construction sites, incorrect design or poor workmanship. The most economical approach to extract water from a sand river as explained in this manual, is to start with a minimum input of labour and materials while ensuring that the quantity and quality of water obtained is worth the investment.

However, not all types of sand rivers can be developed cost effectively to yield sufficient water. The sand rivers with the highest potential contain coarse sand, are flooded a few times every year, have a minimum width of sand of five metres and an average depth of sand of at least one metre.

Sand rivers with waterholes

In sand rivers with waterholes, which provide water for at least one month after the last flooding, the approach should be to start with building a hand-dug well in a riverbed (Plate 2) or a river-intake with a well shaft in a riverbank. Should the well or intake not supply sufficient water, the yield of water can be increased by building a subsurface dam of soil on an underground dyke downstream of the well or intake (Plate 3). Should this still not be sufficient, then the volume of the sand reservoir can be increased by building a subsurface dam of 50-cm height above the sand level with rubble masonry next to the subsurface dam built of soil (Plate 4). Should the yield still not be sufficient, then a sand dam can be built. It should be noted that this is the most difficult and expensive option for extracting water from sand (Plate 5).



Plate 2: *A hand-dug well with a hydrodynamic well head being build.*



Plate 3: *A community building their subsurface dam of soil.*



Plate 4: *A hand-dug well with a subsurface dam downstream.*



Plate 5: *Building a sand dam of rubble stone masonry.*

Sand rivers without waterholes

In sand rivers without waterholes, the approach is different because the reasons for the absence of waterholes may be that;

- the reservoir could leak due to fractured rocks or boulders draining water underground. Such leakage may benefit a nearby borehole.
- the floor under the sand is flat and lacking underground dykes, which can trap water and facilitate waterholes.

In both cases, the most practical and economical approach is to build a subsurface dam of soil and wait for floods to fill the sand reservoir with water. The yield of water can be monitored thereafter by digging a few waterholes. Should the waterholes dry up quickly after floods, then the sand reservoir is leaking and the site might have to be abandoned. If the yield is sufficient for a month or so, then it is possible to proceed as described in chapter 3.

2 SURVEY OF SAND RIVERS

2.1 Flooding of sand rivers

Sand riverbeds contain sand in which floodwater infiltrates the voids between the sand particles. While floodwater on the surface of riverbeds is rapidly drained downstream by gravity, the water trapped in the sand seeps downstream at a lower velocity.

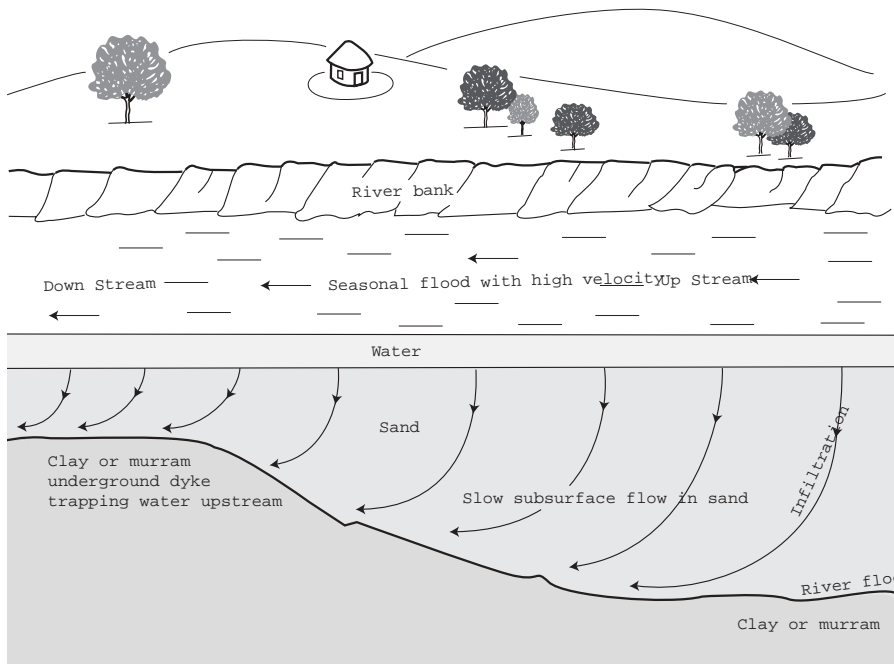

Figure 2: Surface and subsurface flows in sand-rivers.

2.2 Floodwater trapped by underground dykes

Sand rivers are drained of water within a few weeks after flooding occurs, unless water is trapped in the sand by protruding underground barriers such as impermeable rocks or upward protrusions of clay or murrum in the floor under the sand. Such invisible barriers are known as underground dykes that can be located by observing drier vegetation on riverbanks. The consequence too, is that there are usually no waterholes on either side of the river where such dykes exist.

Underground dykes create water reservoirs on the upstream of the dykes from where water may be extracted throughout the dry seasons, provided that the side floor and banks of the riverbeds consist of impermeable soil without fractured rocks, boulders or calcrete deposits.

Underground dykes can be extended upwards to reach the surface of the sand by constructing subsurface dams upon the dykes. Should a subsurface dam not yield sufficient water, then a sand dam can be built to several metres above the sand level.

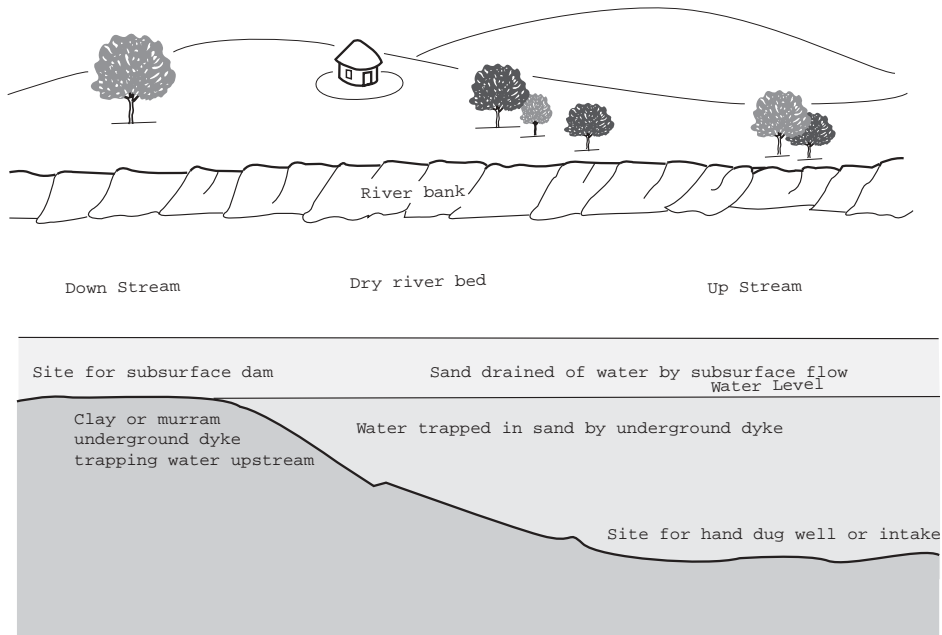

Figure 3: *Underground dyke trapping water upstream in the sand.*

2.3 Identifying underground water reservoirs

Underground water reservoirs can be identified by a combination of six simple methods of investigation, namely;

- evaluating waterholes dug in riverbeds,
- identification of water-indicating vegetation (see next page),
- water dowsing (see page 9),
- probing with iron rods (see page 10),
- digging trial pits (see page 13), and/or
- hand-augering with small auger rods or hand drilling with, for example, a Vonder Rig.

2.4 Tools and equipment for surveying sand rivers

- 2 dowsing rods (see page 9).
- 2 probing rods (see page 11).
- 1 mason hammer.
- 1 circular water level (see page 13).
- 1 open container with a volume of 20 litres (see page 14).
- 6 transparent plastic bottles for soil samples.
- 1 tape-measure, 30 metres long.
- 1 calculator.
- 6 sheets of size A3 graph paper.
- 1 ruler, pencil and rubber.
- 1 copy of this manual.
- A contour map preferably 1:50,000.

2.5 Water-indicating vegetation

Table 1: *Water-indicating vegetation*

Botanical name	*Kamba name	Swahili name	Depth to Water (m)
Cyperus rotundus	Kiindiu		3 to 7
Vangueria tomentosa	Kikomoa	Muiru	5 to 10
Delonix elata	Mwangi		5 to 10
Grewia	Itiliku	Itiliku	7 to 10
Markhamia hildebranditi	Chyoo	Muu	8 to 15
Hyphaene thebacia	Ilala	Kikoko	9 to 15
Borassus flabellifer	Kyatha	Muumo	9 to 15
Ficus walkefieldii	Mombu		9 to 15
Ficus natalensis	Muumo	Muumo	9 to 15
Ficus mallatocapra	Mukuyu	Mkuyu	9 to 15
gelia aethiopica	Muatini	Mvungunya	9 to 20
Piptadenia hildebranditi	Mukami	Mganga	9 to 20
Acacia Seyal	Munina	Mgunga	9 to 20

* Kamba is an indigenous Kenyan language spoken by Bantus in the Eastern province of Kenya.

Preferably, two or more of the water-indicating species of vegetation should be found on a site to confirm viability.

2.6 Depth of roots of water indicating trees

The height of a mature water-indicating tree can give an observer an idea of the depth to the water table by estimating the depth of the roots of a mature tree. As a rule of thumb, the taproot of a tree is three-quarters of its height.

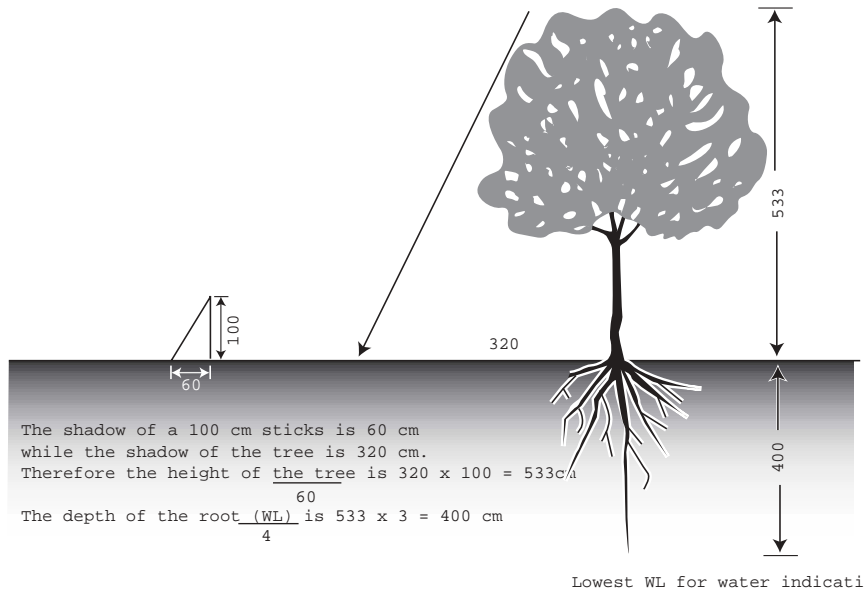

Figure 4: Measuring the height of a tree and its roots.

2.7 Dowsing

Gifted persons can dowse accurately. Most others can learn it in a few days of practical training on identifying full water pipes buried underground. Dowsing is only possible when soil and sand river conditions are almost dry. This usually occurs a couple of months after rains. Below is the procedure for dowsing;

- i) Make a pair of dowsing rods by cutting a full 100 cm length of a brazing rod for gas welding at its middle. Then mark each length at 12 cm from one end and bend them to 90 degrees.

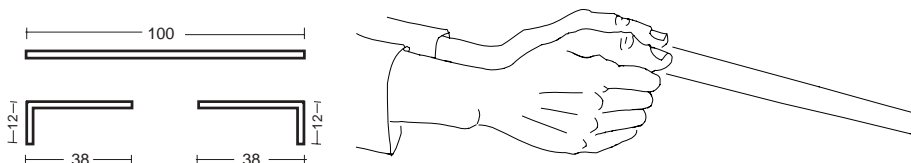

Figure 5: Dowsing rods.

- ii) Hold the short ends of the two dowsing rods loosely in your hands then let the long ends point forwards and slightly downwards to allow gravity pull the rods parallel to each other.
- iii) Now walk forwards slowly and quietly. Where water, or a water pipe, is hidden under the surface, the long ends of the rods will be pressed upwards and cross each other against the law of gravity. With some people, the rods spread apart rather than crossing.

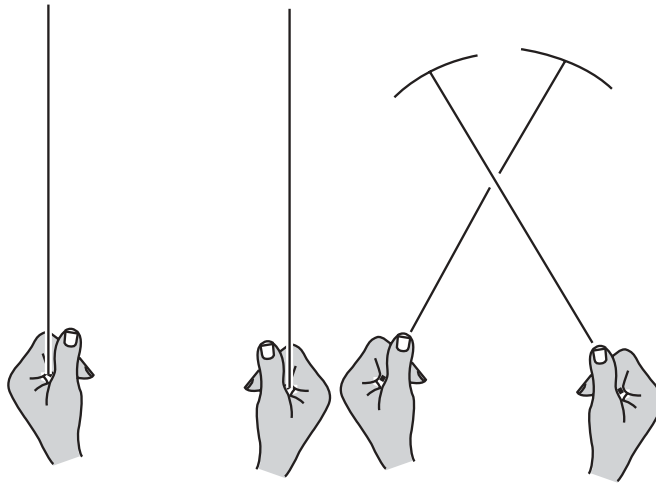

Figure 6: *Reading dowsing rods.*

Strong upward pressure on the rods indicates that there is water near the surface. Lower pressure indicates either less water or water being at a deeper depth from the surface.

Should the rods give no response, the reasons may be that there is either no water underground, or the person dowsing has insufficient experience, or lacks the gift of being able to dowse.

2.8 Probing

Probing of sand rivers is used to assess depths of sand, which indicate that there are underground dykes suitable for dam walls or depressions suitable for hand-dug wells or river-intakes. Probing should take place a couple of months after rains, when the water table is at its lowest.

Probing and auguring can produce almost similar results of investigations but since probing rods can be made locally and are less tiresome to use than auger drills, most

people prefer probing, although auguring gives more definite results. Below is the probing procedure;

- i) To make a probing rod, buy a 6 metre length of 16 mm round (not twisted) iron rod and cut it into two lengths of 2.5 and 3.5 metres long. Make one end of the rods pointed and cut 3 mm deep notches sloping upward in the alternate sides of the rods every 25 cm.

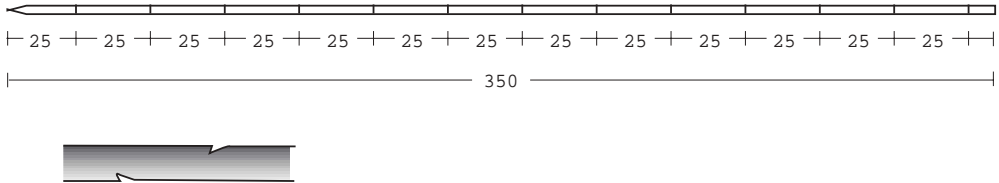

Figure 7: *A probing rod.*

- ii) While standing on a three-legged ladder made from thin poles, start probing in the middle of a riverbed near the best waterhole. Do this by hammering a probing rod vertically into the sand using a mason hammer until a dull sound and slow progress shows that the floor under the sand has been reached by the pointed end of the probing rod.
Mark the level of the sand onto the rod with a piece of charcoal or chalk. Then pull up the rod by hand without bending it and record the following marks and signs found on the rod;
 - the depth of water level (if any). This is shown as wetness on the rod and its depth is measured from the sand surface,
 - the depth of sand in the riverbed, measured from the point of the probing rod to the marked sand surface,
 - the type of floor under the sand as can be seen by the material sticking onto the point of the rod, and
 - the coarseness of sand as seen in the notches of the rod.
- iii) Thereafter proceed probing downstream from the waterhole with intervals of 20 metres until that dyke which traps water for the waterhole is found.
- iv) Now probe across the found dyke with intervals of three metres to ensure that the dyke is fully extended across the riverbed.
- v) Proceed probing upstream from the waterhole with intervals of 20 metres until a second dyke is found which is the upper end of the reservoir created by the downstream dyke and probe across the dyke to ensure it is fully extended across the riverbed.
- vi) Complete the probing by trying to locate the deepest sand near the waterhole from where water can be drawn by a river-intake in the bank or a hand-dug well with a hydrodynamic well-head in the riverbed itself.

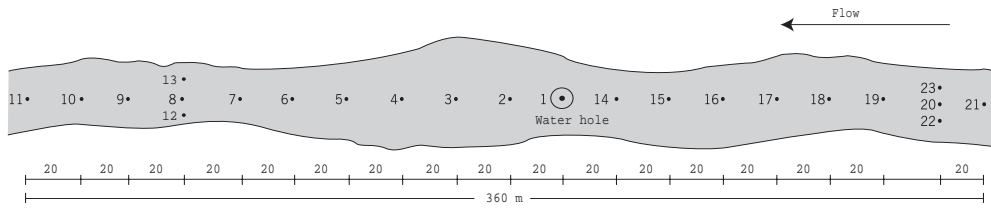

Figure 8: Probing pattern in a riverbed.

2.9 Probing records

Where it is important to know the volume of water that can be extracted from a sand reservoir, it is necessary to fill in a sheet of probing data. Such data can be used for drawing profiles and estimating the volumes of sand and water as shown below.

Table 2: Example of probing data.

Probing Number	Distance to last probing	Width of riverbed	Depth of water	Depth of sand	Types of sand	Height of river banks
1	0	12.1	1.6	Medium		3 + 4
2	20	15.2	1.0	4.4	Medium	3 + 4
3	20	17.1	0.3	3.7	Medium	3 + 4
4	20	15.2	NIL	3.1	Course	4 + 5
5	20	12.2	NIL	2.4	Course	4 + 5
6	20	10.1	NIL	1.9	Course	4 + 5
7	20	9.9	NIL	1.2	Coarse	4 + 6
8	20	9.5	NIL	1.0	Coarse	5 + 5
9	20	10.2	NIL	1.4	Course	4 + 5
10	20	11.0	NIL	2.0	Fine	4 + 5
11	20	11.5	NIL	2.4	Fine	4 + 6
12	3	9.5	NIL	0.8	Fine	4 + 6
13	3	9.5	NIL	0.8	Fine	4 + 6
14	20	11.4	1.8	5.2	Coarse	3 + 4
15	20	12.0	0.6	4.5	Coarse	3 + 4
16	20	12.2	NIL	3.6	Coarse	3 + 4
17	20	11.5	NIL	2.5	Medium	3 + 5
18	20	11.3	NIL	2.0	Medium	3 + 5
19	20	11.7	NIL	1.0	Medium	3 + 4
20	20	12.6	NIL	1.0	Medium	3 + 4
21	20	12.9	NIL	2.1	Medium	3 + 4
22	3	11.4	NIL	4.8	Medium	3 + 4
23	3	11.4	NIL	4.6	Medium	3 + 4

2.10 Gradient of riverbeds

In order to draw a longitudinal profile of a riverbed as seen in figure 11 and 12, it is necessary to find the gradient of the sand surface from where the probing data is measured.

The simplest way of measuring a gradient is by using a circular hosepipe, that is half-filled with water. The person sighting should mark his/her eye height on a stick and place it 100 metres upstream, sighting along the two water-levels in the hosepipe, via a horizontal line that is projected to the stick held vertically upstream in the riverbed at a distance of 100 metres. The difference in height from the sighting person's eye to the mark on the stick gives the gradient per 100 metres (see figure 9).

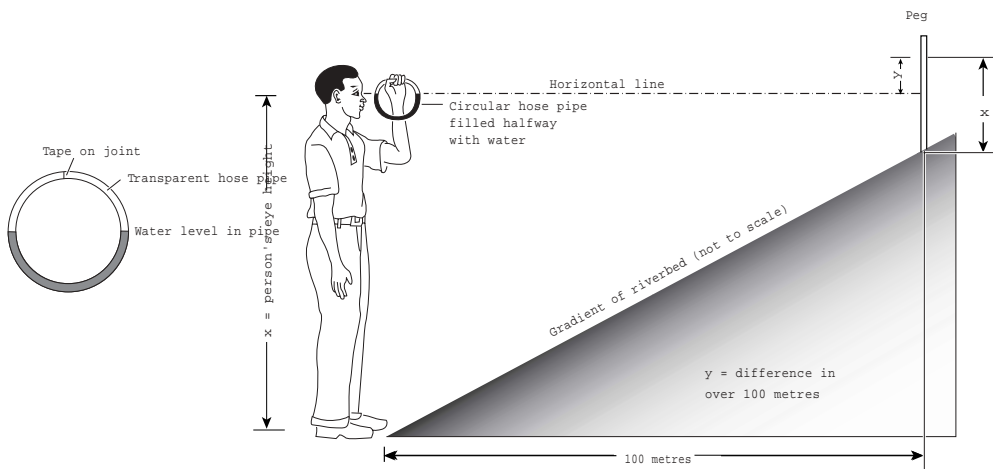

Figure 9: *Measuring the gradient of the sand surface in a riverbed using a circular hosepipe half filled with water.*

2.11 Trial pits / augering

To confirm findings on waterholes, water-indicating vegetation, dowsing and probing, it is necessary to dig trial pits or auger on;

- the underground dyke where the sand is most shallow, and
- the deepest part of the sand reservoir. If it is difficult to dig due to water, then probe in the bottom of the trial pits.

2.12 Porosity and extractability of water from sand

Sand consists of small stone particles that originate from erosion of stones and rocks in the catchment of a sand river. Sand particles have uneven surfaces with voids in

between them. In dry sand, these voids contain air that is displaced by floodwater. The volume of the voids, also known as porosity, determines how much water can be held and extracted from sand.

The porosity can be found by saturating a known volume of dry sand, with a known volume of water. For example if it takes 8 litres of water to saturate 20 litres of dry sand, the porosity is given by:

$$\frac{8 \text{ litres of water} \times 100}{20 \text{ litres of sand}} = 40\% \text{ porosity}$$

The amount of water flowing out of the sand through a small hole in the bottom of the container is measured during one hour after which the sand is drained for water.

If, for example, 5 litres of water can be extracted from 20 litres of sand, then 25% water can be extracted from the sand as given by the equation below;

$$\frac{5 \text{ litres of water} \times 100}{20 \text{ litres of sand}} = 25\% \text{ extract}$$

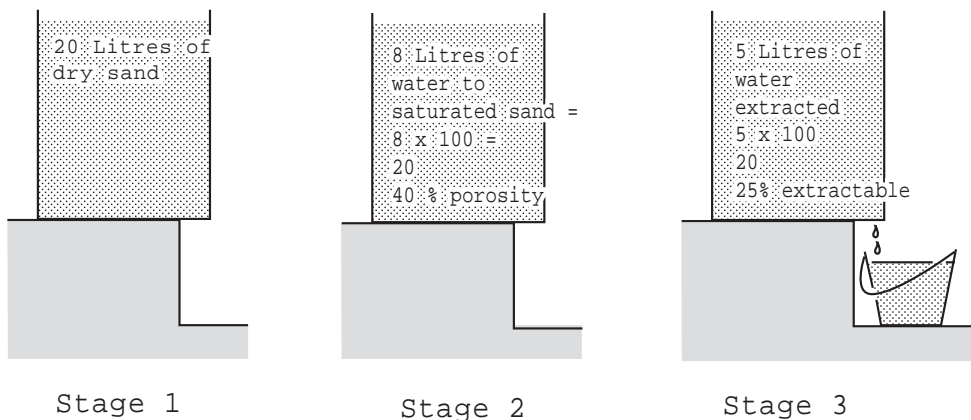

Figure 10: *Measuring porosity and water extracted from sand.*

Table 3: *Porosity and extractable volume of water.*

	Silt	Fine sand	Medium sand	Coarse sand	Fine gravel	Coarse gravel
Diameter of particles	<0.5 mm	0.5 to 1.0mm	1.0 to 1.5 mm	1.5 to 5.0mm	5.0 to 19.0mm	19 to 70.0mm
Volume of sand	20.0 litres	20.0 litres	20.0 litres	20.0 litres	20.0 litres	20.0 litres
Porosity	1.52 litres 38%	1.58 litres 40%	1.63 litres 41%	1.80 litres 45%	1.87 litres 47%	2.05 litres 51%
Extracted water	0.90 litres 5%	3.75 litres 19%	5.00 litres 25%	7.00 litres 35%	8.25 litres 41%	10.00 litres 50%

The example clearly shows that coarse sand yields most water, while silt and fine sand yield much less.

2.13 Estimating the extractable volume of water from a sand reservoir

- First draw a plan and a longitudinal profile of the riverbed using the probing records listed in table 2.
- Start with drawing the horizontal water level (WL) with the dam site drawn on the left side of a graph paper of size A3. Then draw the gradient of the sand surface starting at the dam wall. Thereafter draw the vertical depth of all the probings and trial pits.
- If the probed riverbed is rather long, then use different scales for instance 1:100 for horizontal distances and 1:10 for vertical distances (see figures 11 and 12).

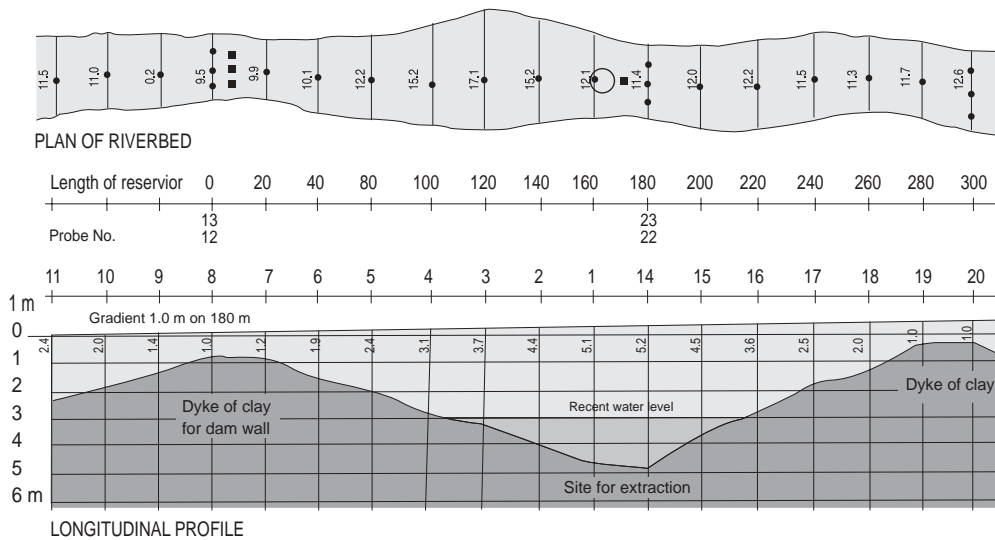

Figure 11: Plan and profile of the probed riverbed.

2.14 Extractable volume of water from sand reservoirs

Use the plan and profile to find the volume of sand below the maximum water level of a sand reservoir by multiplying the following;

- throw-back (tb) of the water level in the sand with
- the maximum width of sand in the riverbed (max.w) and
- the maximum depth of sand below the level of the dyke (max.d), then
- divide the sum by a factor of 3.

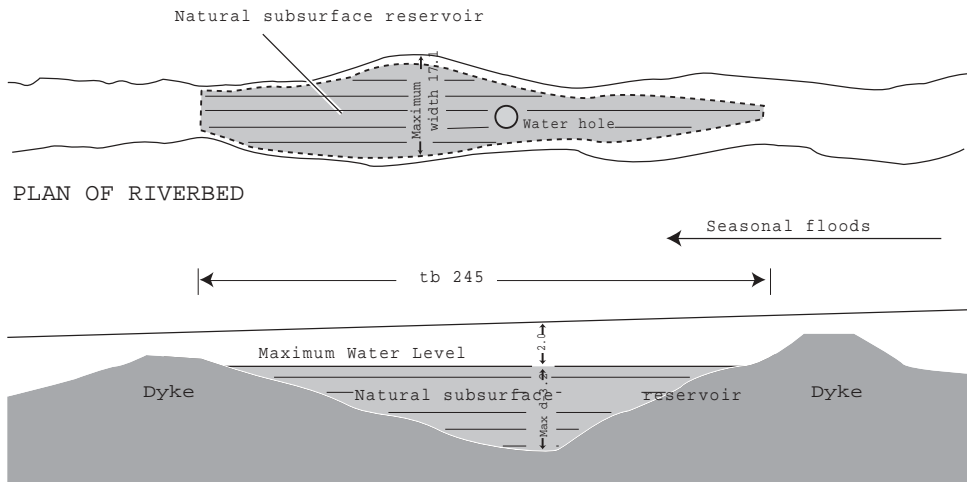

Figure 12: An example of a sand reservoir.

In the above figure, the volume of water stored is found from:

$$\frac{245\text{m} \times 17.1\text{m} \times 3.2\text{m}}{3} = 4,469 \text{ m}^3 \text{ of sand}$$

The volume of extractable water from the sand reservoir is then found by dividing the sand volume, 4,469 m³, by the percentage of extractability. For a medium sand with an extractability of 25% as in section 2.12 and 2.13, the calculation is as shown below;

$$\begin{aligned} \text{Extractable volume} &= \frac{4,469 \text{ m}^3 \times 25}{100} \\ &= 1,117 \text{ m}^3 \text{ of water} \end{aligned}$$

The example above shows that 1,117 cubic metres (1,117,000 litres) of water can be extracted from the sand reservoir by sinking a hand-dug well, a shallow borehole or a river-intake.

2.15 Identifying suitable sand rivers

Since silt can only yield about 5% of water while coarse sand can yield up to 35%, it is important to find sand rivers, or stretches of sand rivers, which contain coarse sand.

Coarse sand is found in sand rivers whose catchments have high gradients (slopes) with stones and rocks. Steep gradients give run-off a higher velocity, which flushes out silt and fine sand while coarse sand and gravel are deposited in the riverbeds. Silt and fine sand, being less suitable for extraction of water, originates from catchments of farmland with flatter gradients. Low gradients in sand rivers slow down the velocity of flash floods. This allows silt and fine sand to settle in riverbeds.

A lot of time and high costs can be saved on surveying for suitable sand-rivers by studying contour maps of scale 1:50,000, using aerial photographs through a stereoscope, thus making the photos three-dimensional. Alternatively, aircrafts are used to observe waterholes and vegetation cover along sand rivers.

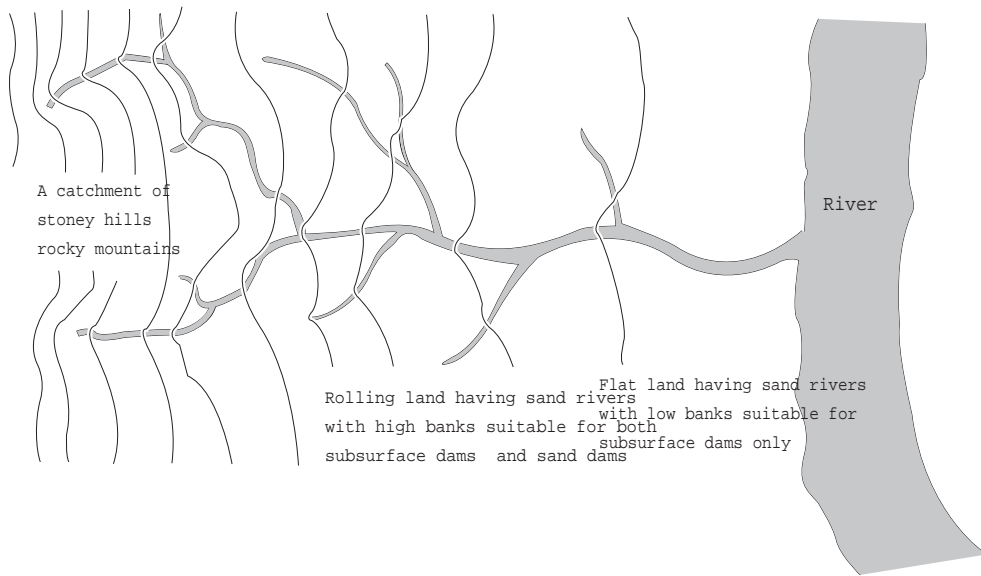

Figure 13: *Map of a catchment area showing the potential for subsurface dams and sand dams in sand rivers.*

2.16 Sand dams in gullies

Sand dams can be built successfully across gullies eroded by an unprotected hillside as demonstrated by the RELMA programme at Kusa near Kendu Bay in Western Kenya.

In addition to supplying water and rehabilitating short stretches of the gullies, the four sand dams so far constructed are also providing cash income for the communities from sale of sand for construction works. Although sand is only removed to a depth of 30 cm from a filled-up sand dam, the cash income from a sand dam returns the construction cost of the sand dam within 2 years.

Construction cost of a Kusa sand dam	= Ksh 70,000
Cash income from 600 m ³ sand @ Ksh 1,400 in 2 years	= Ksh 84,000

3 STRUCTURES FOR EXTRACTING WATER FROM SAND-RIVERS

3.1 Waterholes

Waterholes are usually situated at the deepest part of sand reservoirs from where they may supply fresh water throughout the dry seasons. Unlined waterholes excavated in the sand are the simplest method for extracting water from sand since it costs nothing but labour.

It is risky to enter deep and unlined waterholes in sand rivers because their sides can cave in and bury people alive. Waterholes should therefore be lined with stones, bricks, blocks or culverts and covered with a concrete slab equipped with a bucket-lift or a handpump to avoid contamination of water and people risking their lives when drawing water.

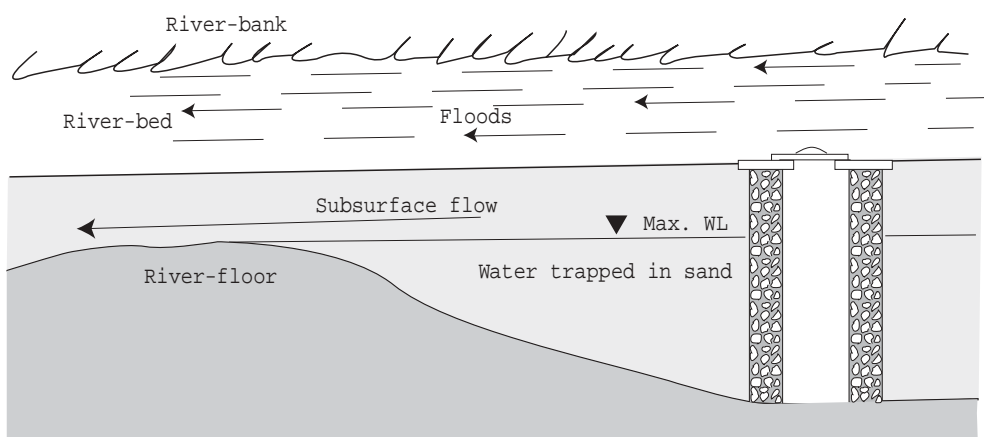

Figure 14: A waterhole lined with flat rubble stones.

3.2 Deep hand-dug wells

Even deep waterholes that are 30 metres or more in sand rivers, can be lined safely and relatively cheaply. This is done with curved concrete blocks built onto a circular foundation ring made of reinforced concrete using the sinking method, which ensures the safety of the well diggers. The sinking method is described in section 5.1

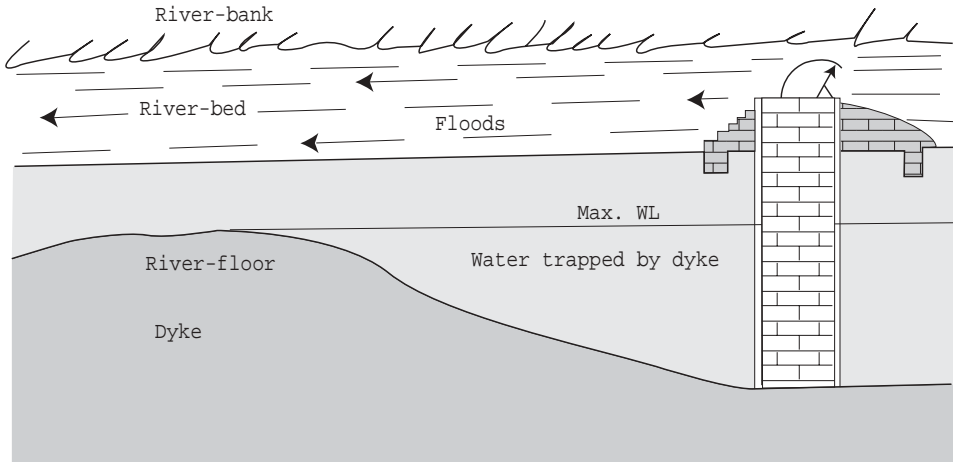

Figure 15: *A sinking hand-dug well with a hydrodynamic well-head.*

A hand-dug well can be built in a riverbed itself but must be protected against flash floods by a hydrodynamic well-head built around the well shaft.

In order to sink a well shaft deeper into the sand without damaging the well-head, a 3 cm space filled with sand is left between the well-head and the shaft as shown on page 35.

A lockable manhole made of a square iron sheet is concreted onto a concrete slab covering the shaft to control usage of water and prevent flash floods from silting up the shaft. The manhole can also be made of a circular concrete slab using a plastic basin for a mould. A circular concrete manhole can be locked onto the concrete slab by iron rods concreted next to the manhole in the concrete slab.

A windlass or a handpump can be fixed onto the wellhead but should be removable in sand rivers with high flash floods.

3.3 Intake pipe with a well shaft in the riverbank

Water can also be extracted from sand by an intake pipe made of a perforated PVC pipe, which drains water from the sand into a well shaft that has been built in the riverbank. The shaft is sunk to a depth of about one metre below the intake pipe to function as a storage tank and to allow for siltation from the intake pipe.

Water can be extracted from a river-intake by a windlass, hand pump, petrol pump or a 12 volt submersible pump powered by a solar panel or a car battery. Design, bill of quantity, cost and procedures for construction can be found in Table 6 on page 37.

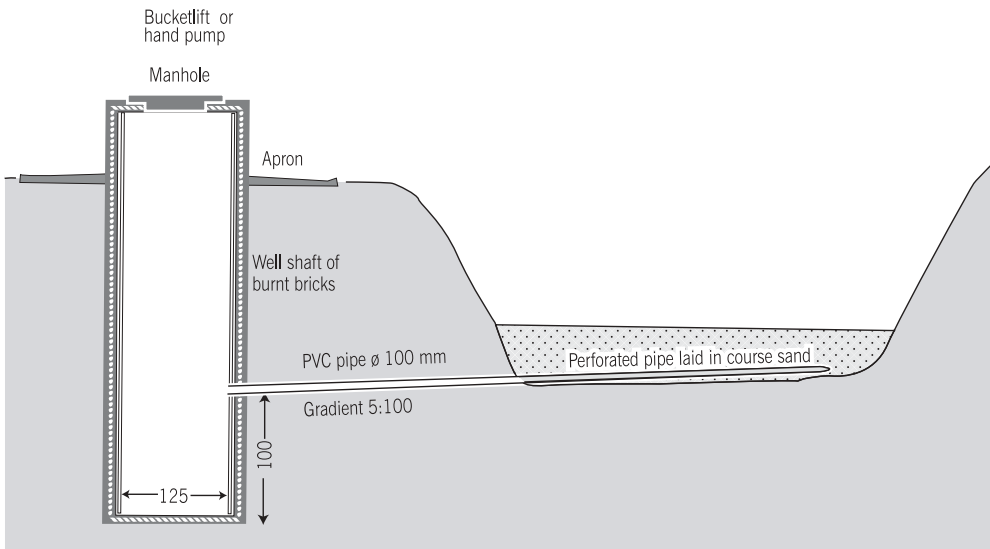

Figure 16: *An intake pipe to a well shaft in a riverbank.*

3.4 Intake chamber with elevated water tank

An intake chamber can be built as a sinking well in a riverbed but it should be sunk one metre into the floor of clay or murrum under the sand. The intake has to be covered with at least one metre of sand to prevent damage by floodwater and to improve filtration of water. The floor of the intake is concreted and the shaft covered with a concrete slab equipped with a manhole.

Water from the sand can enter the intake chamber in two ways; either through a 100 mm PVC pipe which has been perforated and inserted in the shaft near the bottom of the sand, or through part of the shaft having an infiltration section made of aggregate with a ratio of 1:0:4.

Water should be extracted by a 12 volt submersible pump that is fitted in a casing of 100 mm PVC pipe. The pump delivers water to an elevated water tank. Either a car battery or a solar panel, can power the submersible pump.

To avoid floods damaging PVC casing, it should be jet-drilled into one of the riverbanks. Jet drilling is a simple way of drilling shallow boreholes. A petrol-driven water pump pushes water through a flexible 50 mm pipe connected to various lengths of 50 mm galvanised iron(GI) pipes. Water comes out of the GI pipe as a jet. This drills a hole into the soil. Used water and drilled out soil particles flows upward along the outer side of the GI pipe.

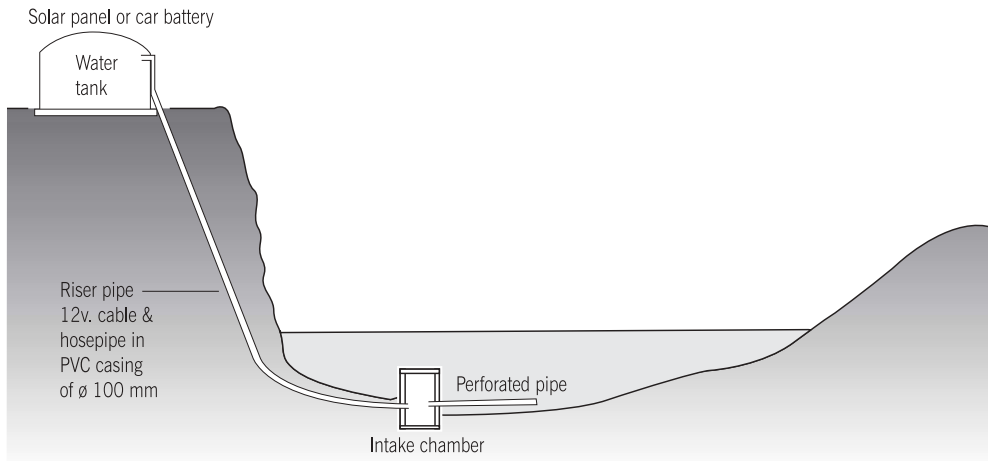

CROSS-SECTION OF SAND RIVER

Figure 17: *Intake chamber with a submersible 12 volt pump.*

4 INCREASING YIELD OF WATER FROM SAND RESERVOIRS

4.1 Subsurface dams built of soil

The function of a subsurface dam is to stop water from seeping downstream in the sand of a riverbed. Water is thus trapped upstream of the dam wall and will increase the yield of a hand-dug well or intake situated there. In order to minimize the work of building a subsurface dam and maximize the storage capacity of trapped water; a subsurface dam should be built on an underground dyke of clay or murrum stretching across the sand of a riverbed.

Subsurface dams can be built cheaply of soil as a weir stretching across the sand of a riverbed. A dam wall is keyed into the banks and the floor under the sand in order to make it watertight. The crest of the dam wall is built to the height of the sand in the riverbed. Soil for the construction of dam walls should be collected from the most clayey spots found in different places at the banks and adjacent land to the construction sites.

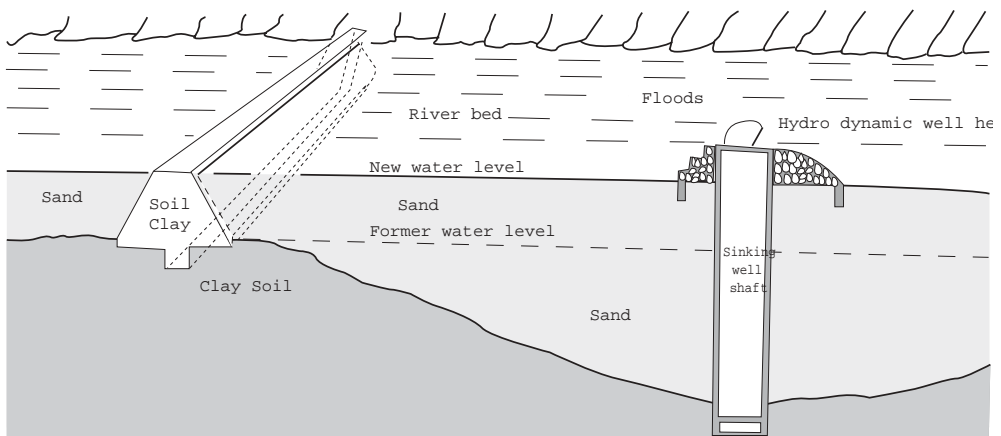

Figure 18: A subsurface dam built of soil on an underground dyke.

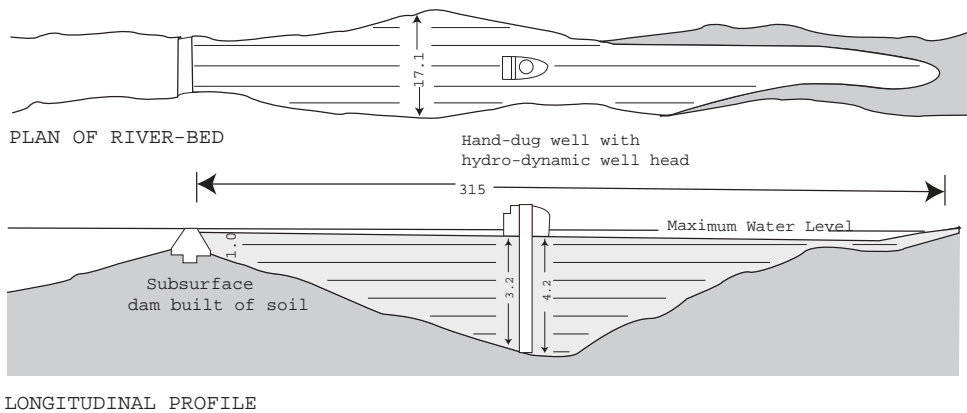

Figure 19: *Estimating the extractable volume of water if the water level is raised 1 metre from 3.2 m to 4.2 m.*

Using the example in section 2.14, the extractable volume of water can be increased from 1,117 m³ to 1,885 m³

$$(tb\ 315\ m\ x\ max.\ w\ 17.1\ x\ max.d\ 4.2) \times 25 = 1,885\ m^3\ of\ water$$

$$3 \times 100\ D$$

Where td = throwback (m)

& Max.d = maximum depth (m)

Design, bill of quantity, cost, construction and maintenance of a subsurface dam built of soil can be found on page 42.

4.2 Subsurface dams built of rubble masonry or concrete

Strictly speaking, this type of subsurface dam is actually a small sand dam because its crest protrudes 50 cm above the level of sand in a riverbed in order to increase the storage capacity. The reason for the maximum height of 50 cm is that floods may overturn the wall if its height protrudes more above the sand level.

Since the walls of subsurface dams and sand dams built of rubble masonry or concrete protrude above the sand level and thus obstruct the water flow, it may be necessary to obtain permission from the local Water Department before construction works are started. Subsurface dams, as well as sand dams which protrude above the sand level require wing-walls to be built into its two banks to prevent floodwater from eroding the banks. If the banks are not prevented, the river would change its course and bypass the dam wall.

To prevent erosion of the riverbanks and its wing-walls, subsurface dams and sand dams should only be built where riverbeds have no bends 50 metres upstream and 25 metres downstream of the dam site. Whether a subsurface dam should be built of rubble stones or of concrete between two walls of burnt bricks, depends on which material is the cheapest at the construction site.

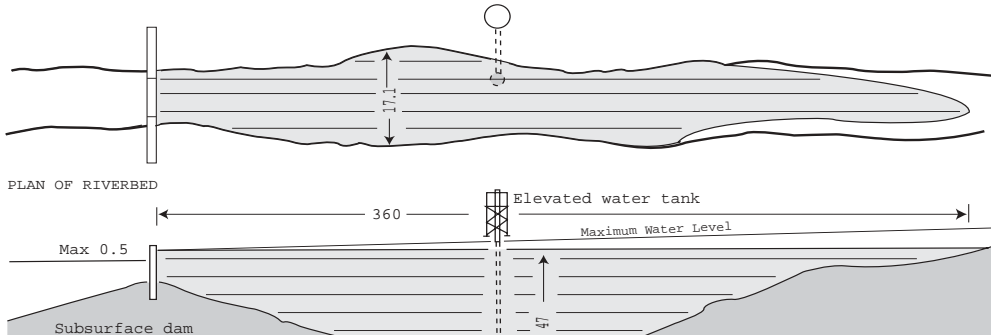

Figure 20: A subsurface dam built of rubble stone masonry.

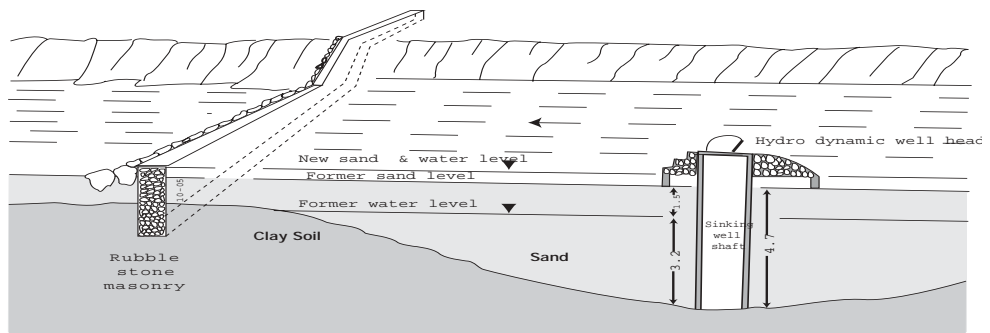

Fig 20

Figure 21: Estimating the extractable volume of water.

Using the example from section 2.14, if a subsurface dam is built to raise the sand level to a height of 0.5 metres ($3.2 \text{ m} + 1.5 \text{ m} = 4.7 \text{ m}$), the volume of extractable water will be increased from $1,117 \text{ m}^3$ to $2,411 \text{ m}^3$

$$(tb \ 360 \text{ m} \times \text{max. w} \ 17.1 \times \text{max. d} \ 4.7) \times 25 = 2,411 \text{ m}^3 \text{ of water}$$

$$3 \times 100$$

Where td = throwback (m)

& Max.d = maximum depth (m)

Design, bill of quantity, cost, construction and maintenance of a subsurface dam built of rubble stone masonry are found in Table 9 on page 45.

4.3 Sand dams built of rubble stone masonry or concrete

Due to its relatively high cost and demand for technical skills, a sand dam should only be built where a subsurface dam has already proved successful but with insufficient yield of water. Whether a sand dam should be built of rubble stones or concrete depends on which material is the cheapest at the construction site. In sand rivers with plenty of rubble stones, the choice should be rubble stone masonry, while in places with coarse sand and pebbles it should be concrete. The latter is however more expensive due to its requirement of timber for formwork.

Sand dams can only be built in sand rivers with high banks but must have wing-walls built into the banks to prevent floodwater from eroding the banks, which if not prevented would cause the river to change its course and bypass the dam wall. To prevent erosion of the riverbanks and its wing-walls, this type of sand dam should only be built where riverbeds have no bends 50 metres upstream and 25 metres downstream of the dam site.

The design presented in this manual originates from the African Land Development Project (ALDEV) by which many sand dams were built in Kitui, Kenya, during the 1950s. Nearly all the sand dams are functioning well even today, despite not having been maintained.

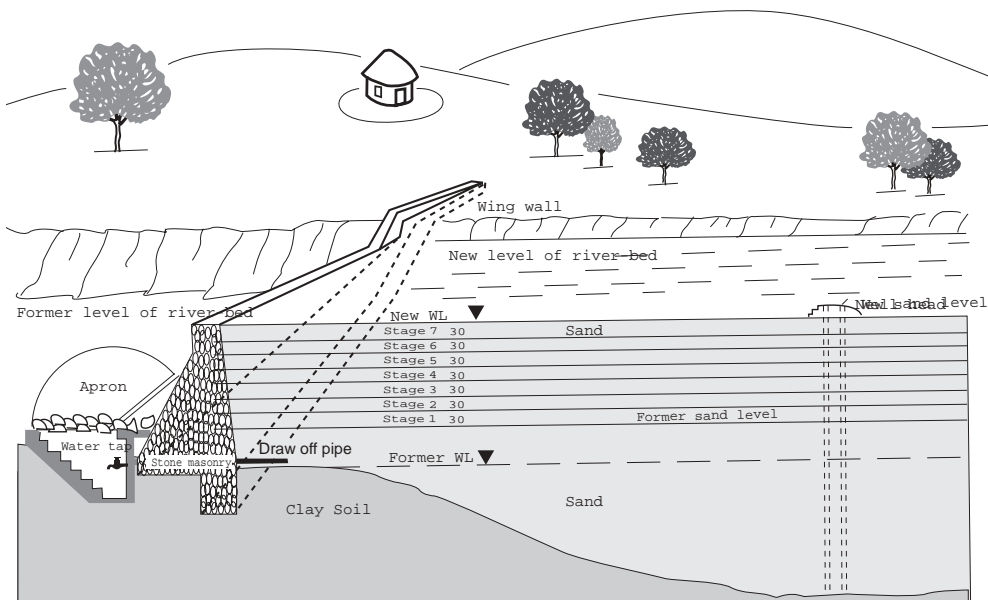

Figure 22: A sand dam built with tap stand and a sinking hand-dug well with a hydrodynamic wellhead.

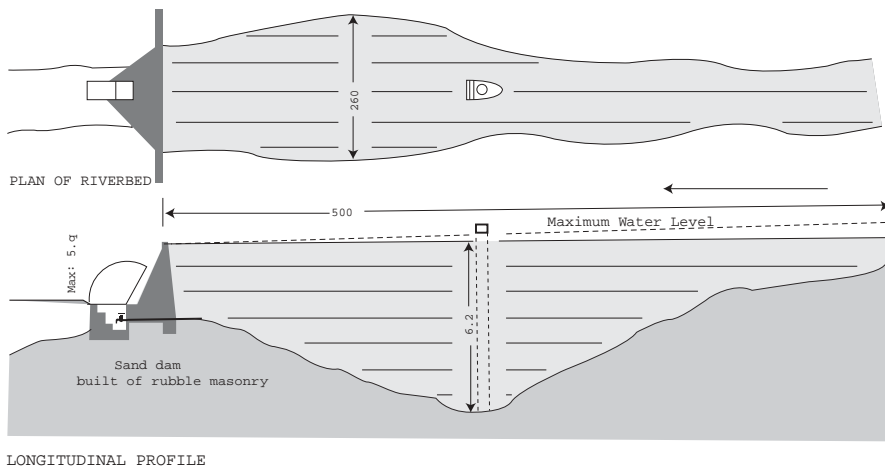

Figure 23: *Estimating the extractable volume of water.*

Using the same example in section 2.14; if a sand dam is built which will raise the level of sand and water by three meters above the original sand level, then the maximum depth will be 6.2 m (3.2 m + 3 m) and the volume of extractable water will be increased from 1,117 m³. to 6,717 m³.

$$(tb\ 500\ m\ x\ max.\ w\ 26.0\ x\ max.\ d\ 6.2) \times 25 = 6,717\ m^3\ water$$

$$3 \times 100$$

Design, bill of quantity, cost, construction and maintenance of a subsurface dam built of rubble stone masonry are found in Table 10 on page 49.

Table 4: *Cost comparison and yield of the shown examples.*

Structures described briefly Reference from page in chapters 3 & 4 and in detail from chapter 5 onwards	Yield of water (m³)	Cost of structure (Ksh)	Cost per m³ water (Ksh)	See page
Hand-dug well in riverbed	1,117	31,230	27.96	16+23
Intake pipe with well in bank	1,117	22,100	19.79	17+29
Intake chamber with tank	1,117	73,800	66.07	18+31
Subsurface dam built of soil with intake and well in bank	1,885	9,000	4.78	19+34
Subsurface dam of masonry with intake and well in bank	2,411	22,100	11.72	17+29
Subsurface dam of masonry with intake and well in bank	2,411	75,700	31.40	20+37
Sand dam built of masonry with intake and well in bank	6,717	22,100	9.17	17+29
Sand dam built of masonry with intake and well in bank	6,717	225,000	33.54	21+40
Sand dam built of masonry with intake and well in bank	6,717	22,100	3.29	17+29

4.4 Flow chart on selecting correct type of structure

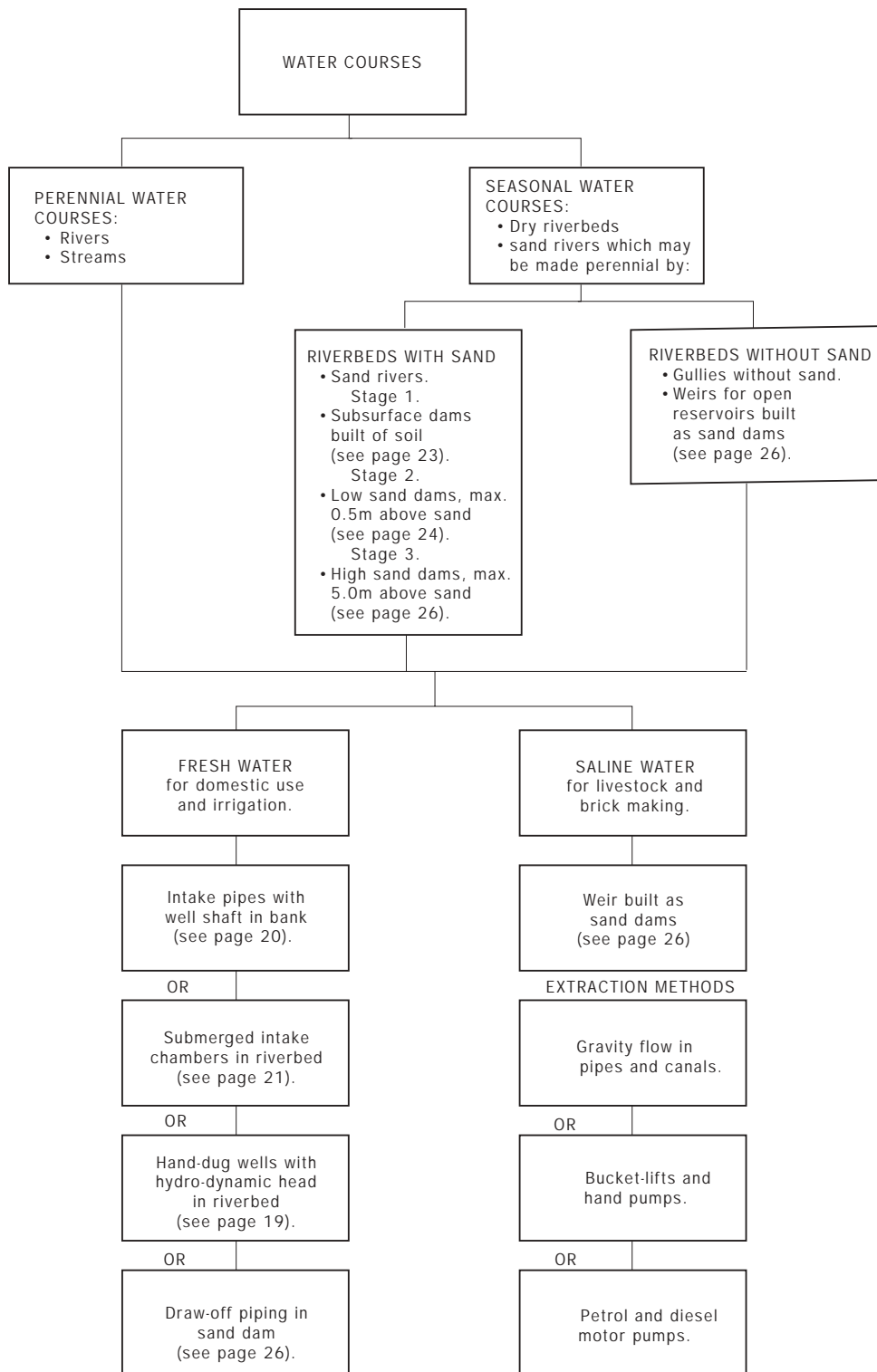

5 DESIGNS, BILLS OF QUANTITIES, COST AND PROCEDURES

5.1 A sinking hand-dug well with a hydro-dynamic well-head

Built by RELMA and ASALCON at Talek, Maasai Mara, in 1999.

CAPACITY (USING THE EXAMPLE ON PAGE 14 AND 17).

Volume of sand reservoir : 4,469 m³ sand.
 25% extractable water : 1,117 m³ water.
 Cost of structure : Ksh 31,230 = Ksh 27.96/m³ water.
 exclusive of the value
 of community work

Table 5: *Bill of quantity and cost of sinking a hand dug well.*

Item	Unit Ksh	Quantity Ksh	Unit cost	Total cost
Cement	50 kg bags	26 bags	500	13,000
Weldmesh	4' x 8'	1 sheet	400	400
G.I. wire	4mm	20 kg.	100	2,000
Chicken mesh	3' 1"	4 metres	70	280
Barbed wire	g 12.5	90 kg.	90	450
Windlass	Unit	1 unit	4,000	4,000
Iron rod	12mm	6 metres	50	300
Sand	Coarse	4 tonnes	Community delivered	
Ballast	1"	1 tonne	Community delivered	
Rubble stones	4" to 10"	4 tonnes	Community delivered	
Total for materials			20,430	
Artisans	1 mason	24 days	450	10,800
Labourers	4 persons	50 days	Community delivered	
Total for labour				10,800
Grand total, excluding value of community work				31,230

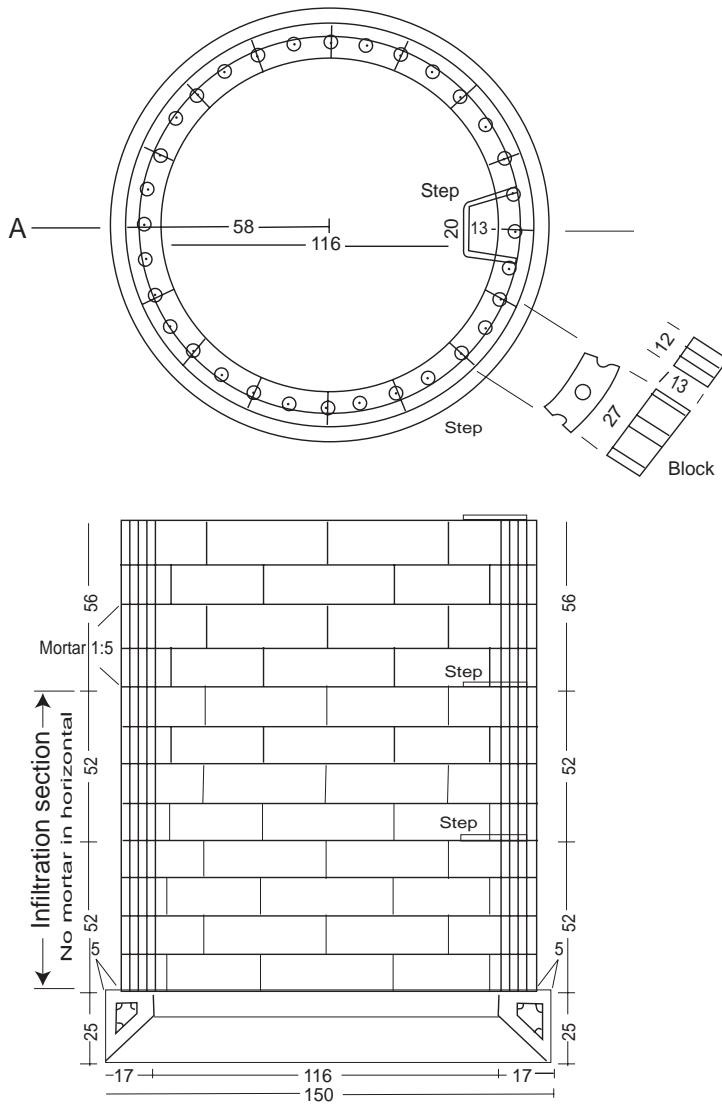

PLAN

Curved concrete blocks. Steps of 16 mm iron rods.

SECTION

Reinforcement of 4 mm galvanized wires. Infiltration section.

Concrete foundation & cutting ring.

Figure 24: Design of a sinking well shaft.

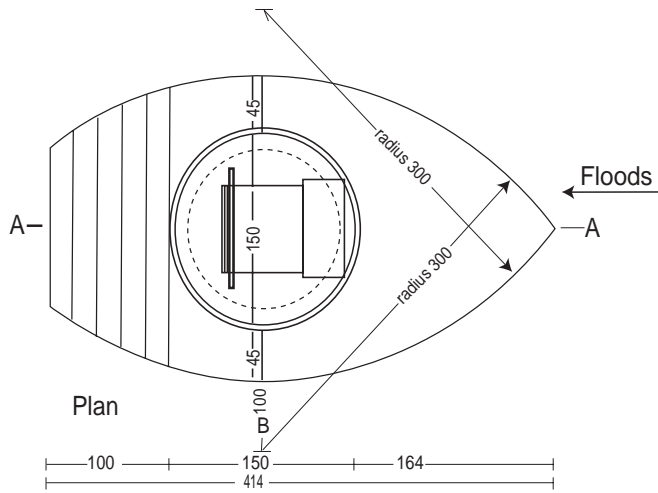

PLAN
Hydro-dynamic well-head

Plan : Hydro-dynamic well head

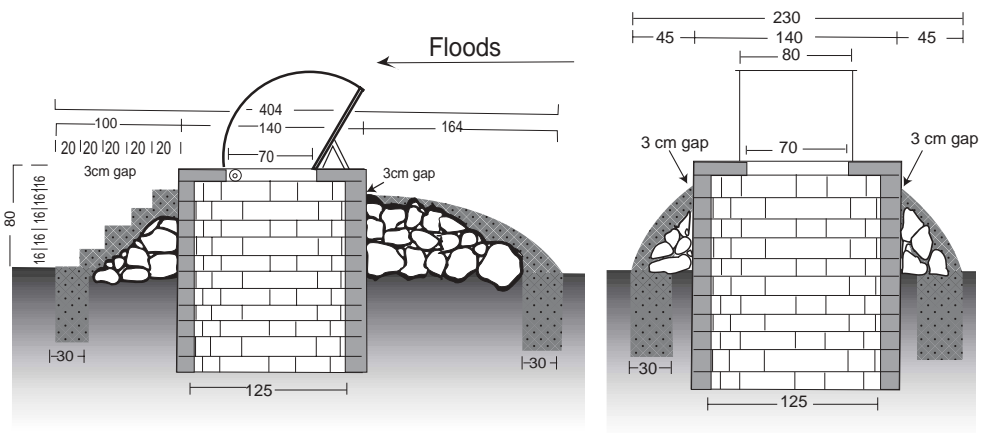

Section A-A

Section B-B

Figure 25: Design of a hydrodynamic well-head.

STEPS IN THE CONSTRUCTION OF SINKING A HAND-DUG WELL

1 *The curved concrete blocks*

Curved concrete blocks for the shaft is made of mortar in the ratio 1:5 compacted in a mould made of metal. It takes 16 blocks to build a circular course with a diameter of 140 cm and a height of 14 cm. This provides 112 blocks for every one metre height of a well shaft.

The blocks are cured under moist sacking at the site of the well. This is done under the shade of a tree.

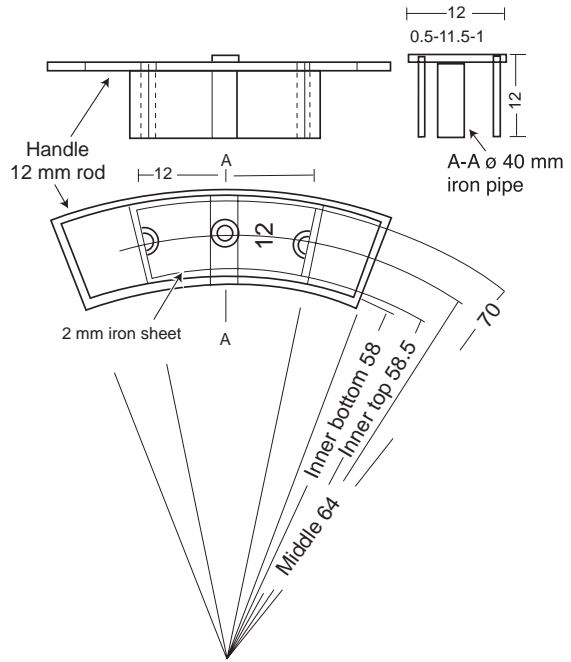

Figure 26: A mould for blocks.

2 *The foundation/cutting ring*

This is done in a groove cut with a tool in the bottom of an excavation in the sand where the well will be located. The ring is made of mortar in the ratio of 1:3:3 reinforced with three rounds and 32 vertical lengths of 44 mm G.I wires

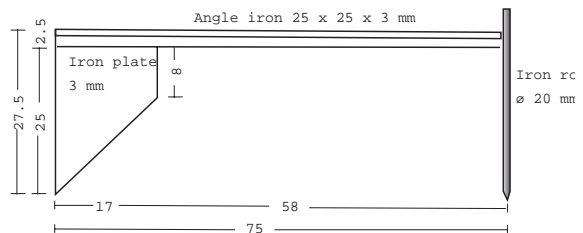

Figure 27: The groove cutting and 32 vertical lengths of tool.

The cutting ring is cured for a few days in its groove before blocks can be build onto it.

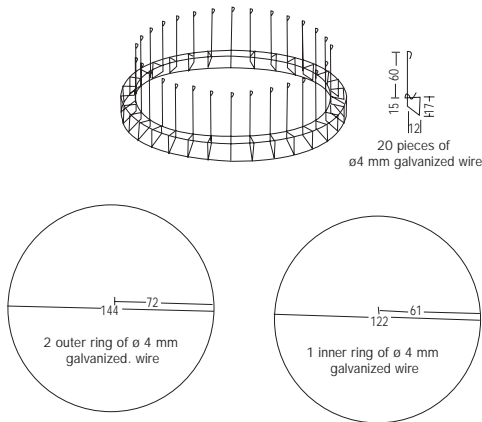

Figure 29: Reinforcement for the cutting ring.

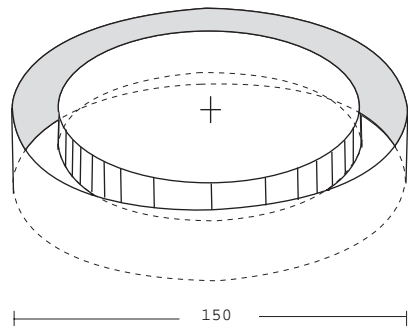

Figure 28: A groove cut in sand as mould for the cutting ring.

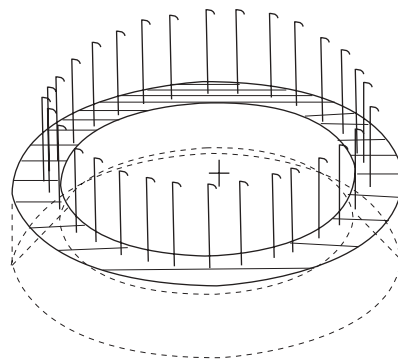

Figure 30: The completed cutting ring.

3 An infiltration section

An infiltration section is made by placing the first eight courses of blocks on the cutting ring without mortar. The outer side of the blocks must be 5 cm from the edge of the cutting ring all around. The vertical wires are made to go through each hole in the blocks. Sand is then back-filled around the shaft and the vertical holes in the blocks are filled and compacted with mortar in the ratio of 1:4.

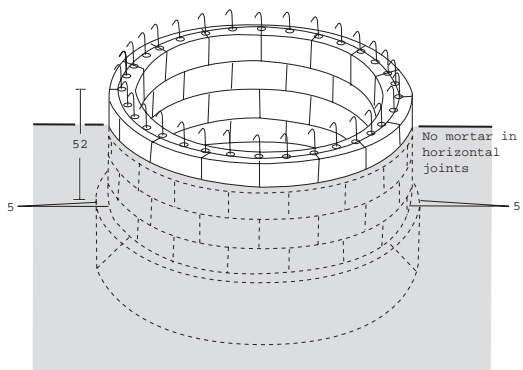

Figure 31: Infiltration section.

4 *Horizontal reinforcement*

This is inserted for every four courses by wrapping a length of 4 mm GI wire around the vertical wires sticking up through the blocks. Tying additional lengths of wires onto them extends the vertical wires.

5 *Steps*

These are made by bending 12 mm iron rods to form steps which are anchored to two of the vertical wires.

6 *The well-Shaft*

The well shaft above the infiltration section is built with mortar of ratio 1:4 between the horizontal courses and in the vertical holes. When the shaft reaches about 60 cm above ground level, sand is dug out from the bottom of the shaft. As sand is removed under the shaft, its weight makes the shaft sink.

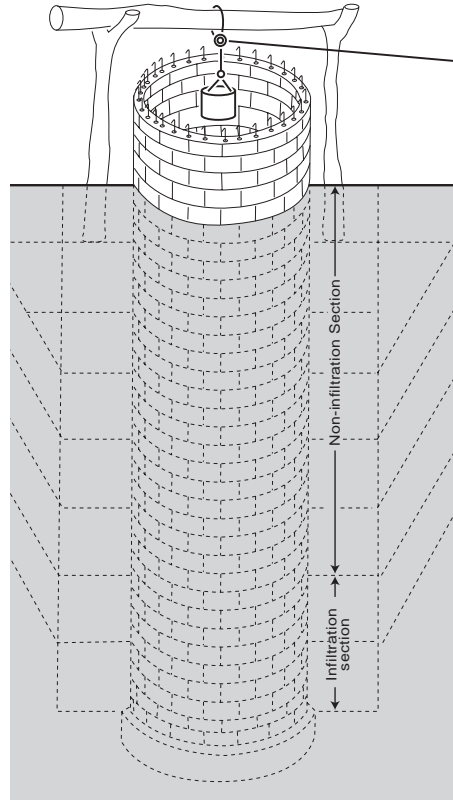

Figure 32: Well shaft.

When the shaft has sunk to the ground level, another section of four courses is added. The shaft is continuously sunk and built onto its top until the final depth has been reached or water stops the sinking procedure. A well shaft can be deepened at a later stage as explained in step 9.

CONSTRUCTION OF A HYDRO-DYNAMIC WELL-HEAD

7 *Mark out the foundation*

This is done by a tying a string to two pegs placed 100 cm from the well shaft and drawing part of a circle with a radius of 300 cm. The downstream end of the circles is reduced to a length of 100 cm from the well shaft to make the first step.

The foundation is excavated to a width of 30 cm and a depth of 60 cm. Concrete of ratio 1:4:4 is compacted into the excavation with two rounds of barbed wire placed 20 cm from the bottom and another two rounds at 20 cm from the top of the excavation.

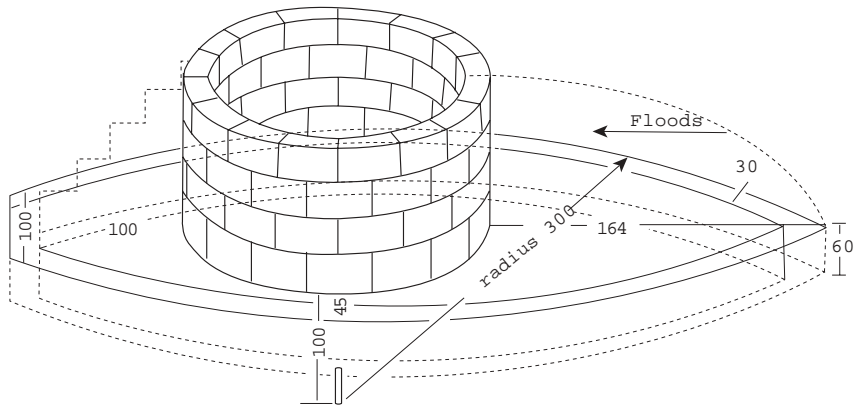

Figure 33: *Marking out and concreting the foundation.*

8 *The well-head*

This is made by wrapping old sacks around the shaft to create a 3 cm gap between the well head and the shaft. The well-head should protrude about 60 cm above the sand. Rubble stones are packed within the foundation and around the well shaft to form the shape of a boat turned upside down. The stones will form some steps at the downstream end of the well-head.

A well cover of concrete with a lockable manhole of steel or concrete is placed on the shaft with the door opening upstream.

The rubble stones are then covered with chicken mesh and a 5 cm thick mortar layer of ratio 1:4 which must be cured by keeping it moist under cover for about three weeks.

A windlass or a handpump can be bolted onto the well cover. In sand-rivers with high flash floods, it is advisable to remove the windlass or handpump before floods.

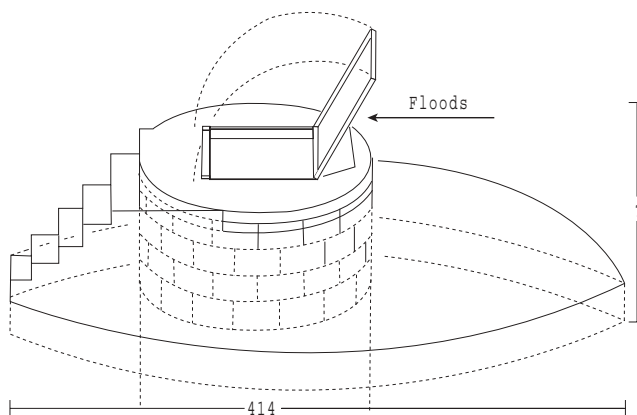

Figure 34: *A hydrodynamic well-head.*

9 *Deepening of a well-shaft*

This is possible when the water level sinks during prolonged drought provided the well-shaft is not resting on a hard rock formation and the 3 cm gap was built between the shaft and well-head as explained above.

First, the well cover must be removed from the shaft to allow the well shaft to be sunk further. Then sand is dug out from the bottom of the well and blocks are added to the top of the shaft as described above.

This process can be repeated several times as long as water or stones do not hinder sinking of the shaft.

OPERATION AND MAINTENANCE

A Well Operator selected by the community should handle the daily operation of a hand-dug well with a hydrodynamic well-head in a sand river.

A Well Operator will unlock the windlass and the manhole during certain hours every day and ensure that water is drawn without damaging the structure. When floods are expected she/he will remove the windlass and lock the manhole every evening.

A Well Operator can be paid a salary by charging a small amount of money for the water drawn.

Maintenance of a hand-dug well with a hydrodynamic well-head should be taken care of by a Well Operator who will;

- clean the shaft of debris, which may have fallen in.
- grease the handles and bearings of the windlass.
- replace the rope and bucket when worn out.
- repair damage done by floods.

5.2 An intake-pipe with a well shaft in a river-bank

Built by Sida & ASALCON at Ivia, Kibwezi, in 1997.

CAPACITY (USING THE EXAMPLE ON PAGE 14 AND 17).

Volume of sand reservoir	: 4,469 m ³ sand.
25% extractable water	: 1,117 m ³ water.
Cost of structure exclusive of the value of community work	: Ksh 22,100 = Ksh 19.79/m ³ water.

Table 6: Bill of quantity and cost.

Item	Unit	Quantity	Unit cost Ksh	Total cost Ksh
Cement	50 kg bags	12 bags	500	6,000
Weldmesh	4' x 8'	1 sheet	400	400
PVC pipe	100 mm	12 metres	100	1,200
Chicken mesh	3' 1"	30 metres	70	2,100
Windlass	Unit	1 unit	4,000	4,000
Iron rod	12 mm	6 metres	50	300
Sand	Coarse	4 tonnes	Community delivered	
Ballast	1"	2 tonnes	Community delivered	
Burnt bricks	Any size	1,200 bricks	Community delivered	
Total for materials				14,000
Artisans	1 mason	18 days	450	8,100
Labourers	4 persons	50 days	Community delivered	
Total for labour				8,100
Grand total, excluding value of community work				22,100

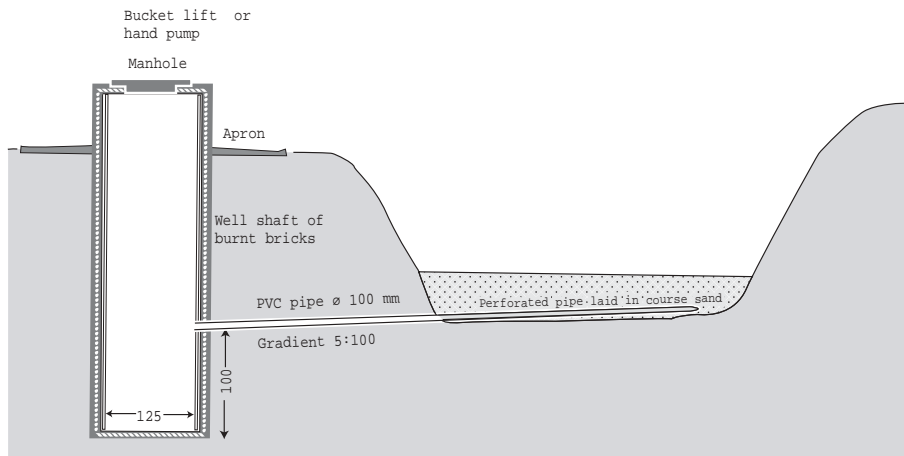
**Figure 35: Design of the intake pipe with a well shaft.**

CONSTRUCTION

1 The trench

This is dug from the deepest part of a sand reservoir into the nearest bank. The floor of the trench must slope at least 1:20 from the floor under the sand, into a well shaft dug in the bank.

2 *The shaft*

This is dug with a diameter of 150 cm and 100 cm deeper than the inlet pipe to create water storage and a sand trap. The floor of the shaft is concreted with 1:4:4. Burnt bricks are built onto the floor till it reaches about 70 cm above ground level. The interior of the well shaft is then plastered to make it watertight with mortar of ratio 1:3 and NIL (thick cement slurry).

3 *The intake pipe*

This is made by perforating a 100 mm PVC pipe with 2" nails heated over a fire. The perforations should be less than 50 mm apart. Woven plastic sacks are wrapped around the perforated PVC pipe, which is then laid in very coarse sand and aggregate. The extension pipe to the well shaft is not perforated.

4 *A well cover with a lockable manhole*

is made and placed on the shaft. A windlass or a handpump can be bolted onto the well cover. An apron is built around the shaft to drain wastewater to a pit.

OPERATION AND MAINTENANCE

A Well Operator who will unlock the windlass and the manhole during certain hours every day and ensure that water is drawn without damaging the structure should handle the daily operation. A Well Operator can be paid a salary by charging a small amount of money for water drawn. A Well Operator who will take care of maintenance will:

- clean the shaft of debris, which may have fallen in.
- grease the handles and bearings of the windlass or handpump.-

5.3 An intake chamber with an elevated water tank

Built by RELMA & ASALCON at Talek, Maasai Mara, in 1999.

CAPACITY USING THE EXAMPLE ON PAGE 14 AND 17.

Volume of sand reservoir	: 4,469 m ³ sand.
25% extractable water	: 1,117 m ³ water.
Cost of structure (exclusive of the value of community work)	: Ksh 73,800 = Ksh 66.07/m ³ water.

Table 7: Bill of quantity and cost.

Item	Unit	Quantity	Unit cost Ksh	Total cost Ksh
Cement	50 kg bags	14 bags	500	7,000
Weldmesh	4' x 8'	3 sheets	400	1,200
G.I. wire	3 mm	15 kg	100	1,500
PVC pipe	100 mm	15 metres	100	1,500
PVC bends	100 mm	6 bends	300	1,800
Water tank on tower		1 unit	20,000	20,000
Solar panel	40 watts	1 panel	15,000	15,000
Submersible pump,	12 volt	1 pump	15,000	15,000
Sand	Coarse	2 tonnes	Community delivered	
Rubble stones	4" to 10"	2 tonnes	Community delivered	
Total for materials				63,000
Artisans	1 mason	24 days	450	10,800
Labourers	2 persons	24 days	Community delivered	
Total for labour				10,800
Grand total, excluding value of community work				73,800

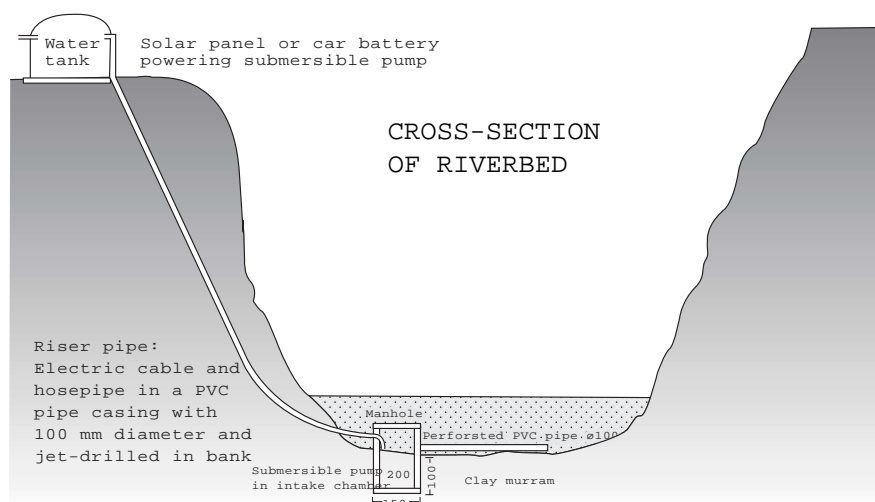
**Figure 36: Design of intake chamber with elevated water tank.**

CONSTRUCTION

1 The intake chamber

This is built as the sinking hand-dug well in the deepest part of a riverbed as described under section 5.2, except that the well shaft can either have an

infiltration section or an infiltration pipe. The depth of the intake chamber should be 100 cm into the floor of clay or murrum under the sand. The height of the intake chamber has to be 100 cm below the sand surface in order to function as a water filter.

To avoid water flooding the work site, a circular barrier of plastic sacks can be filled with sand and placed around the site while water is scooped or pumped out.

2 *The infiltration pipe*

This is made by perforating a 100 mm PVC pipe with 2" nails heated over a fire. Woven plastic sacks are wrapped around the infiltration pipe. The pipe is then placed near the river floor and covered with very coarse sand and mortared into a hole cut in the chamber.

3 *Casing for a submersible pump with its electrical cord and delivery pipe*

This consists of a 100 mm PVC pipe that is jet-drilled from the surface of the bank to the intake chamber. The drilling is made using a petrol pump to deliver water via a 50 mm hosepipe to different lengths of 50 mm GI pipes.

The open end of the GI pipe is placed against the soil where its jet of water will drill a hole. The soil and used water are pushed upwards around the outer side of the GI pipe while enlarging the hole to fit the 100 mm PVC pipe. The first short drilling pipe is replaced with longer lengths whenever the pipe has drilled itself into the ground.

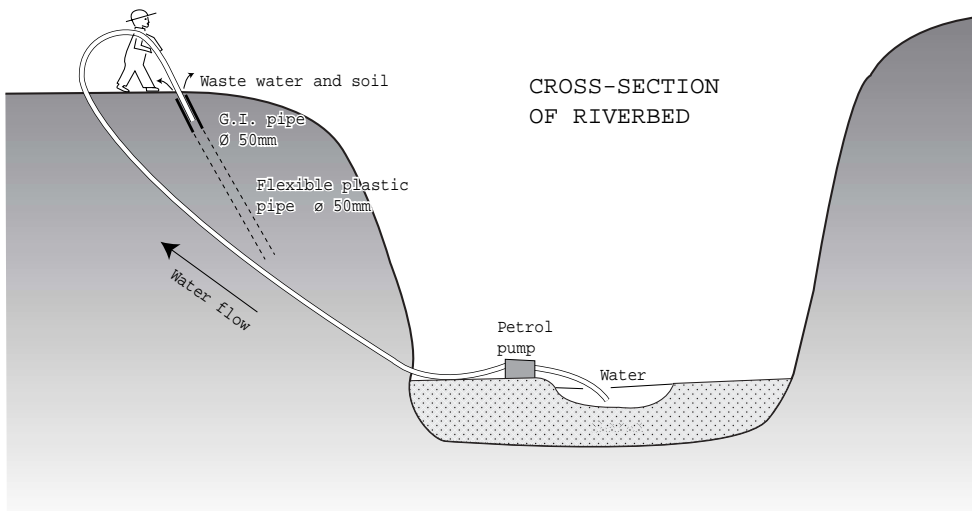

Figure 37: Jet-drilling a hole in a riverbank.

When the hole has been drilled to below the sand level, a trench is dug into the hole and the 100 mm PVC casing is pushed into the hole while the soil is still moist. The PVC pipe is now mortared into a hole cut in the chamber.

- 4 A water tank with a storage volume sufficient to cover the demand for a week or so, say 10,000 litres, is built on the bank near the upper end of the casing pipe. Placing it on a tower or a nearby rooftop can elevate the tank.
- 5 A submersible water pump for electricity of 12 Volts and with adequate delivery capacity for the given head is connected to an electrical cable of the required size and length which is connected to either a solar panel placed on the water tank or a car battery.

A hose-pipe of the required size and length is then connected to the submersible pump. The pump with its electrical cable and hosepipe is lowered into the casing in which it glides into the intake chamber. When the pump is hanging in the middle of the intake chamber, the cable and hosepipe are fastened to the top of the casing to keep the pump in its position. If the pump is placed too low, it will suck in sand and be destroyed. Should the water level drop below the pump, it must be stopped to avoid being spoiled.

Avoid complications and costs by connecting the solar panel directly to the pump without battery and regulator but with a switch. When the tank is full of water, its overflow can be diverted to a cattle trough or back to the sand-river.

OPERATION AND MAINTENANCE

The daily operation only requires that the pump is either powered by sunshine or a car parked nearby with a charged battery.

Maintenance requires inspection of the intake chamber for the first few weeks to ensure that sand and silt cannot enter the pump. Once the rate of siltation is reduced to zero, the chamber should only be inspected and cleaned out during dry seasons. Should the pump need service or repair, it can be pulled up through the casing.

5.4 A subsurface dam built of soil

Built by Sida & ASALCON at Ivia, Kibwezi, in 1997.

CAPACITY USING THE EXAMPLE ON PAGE 14 AND 17.

Volume of sand reservoir : 7,540 m³ sand.
 25% extractable water : 1,885 m³ water.
 Cost of structure : Ksh 9,000 = Ksh 4.78/m³ water.
 (exclusive of the value
 of community work
 + cost of intake in bank) : Ksh 22,100 = Ksh 11.72/m³ water.

Table 8: *Bill of quantity and cost.*

Item	Unit	Quantity	Unit cost Ksh	Total cost Ksh
Soil	Tonnes	124 tonnes	Community delivered	
Artisans	1 mason	20 days	450	9,000
Labourers	8 persons	30 days	Community delivered	
Total for labour				9,000
Grand total, exclusive value of community work			9,000	

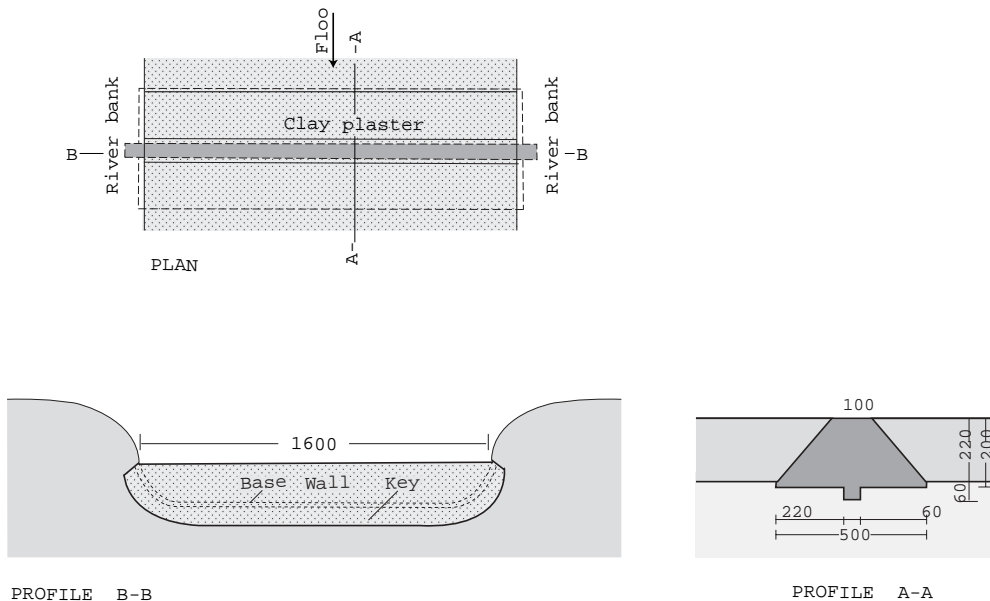

Figure 38: *Design of a subsurface dam built of soil.*

DESIGN CRITERIA

- 1 The construction site for a subsurface dam should be on an underground dyke of clay, soil or murrum under the sand in a riverbed because of the following:
 - A natural dyke provides a natural water reservoir just upstream of the dyke.
 - The sand on the dyke is shallowest therefore requiring less work and cost to build a subsurface dam.
 - Water will not hamper the construction work because a dyke is the first part of a sand river to dry up. Should an underground dyke not be found in a sand-river, a subsurface dam can be built cheaply of soil to test the yield of water from the sand reservoir created by the subsurface dam.

- 2 The design criteria are modified from Tanganyika Railway (1900) and are based on the following five items:
 - *The height of a dam wall.* This stretches from the dyke to the sand surface. The depth of sand on a dyke is found by probing and digging trial pits.
 - The gradient of the upstream and downstream sides of a dam wall should be 45 degrees at each side.
 - *The base of a dam wall.* This is excavated 20 cm below into the dyke and the banks below sand level.
 - *A key,* 60 cm wide, is excavated along the middle of the foundation and the banks below sand level. The depth of the key is 60 cm below any layer of sand found in the key to prevent seepage under the dam wall.
 - *The width of the crest.* This depends on the type of soil used for building the dam wall. A 100 cm wide crest is made of the best clayey soil found on a construction site. Sandy soil is plastered on the upstream side with clay. The best soil type is found by filing soil samples into plastic bottles placed upside down without cap and bottom in sand. Water is poured on the samples while observing the rate of infiltration; the slowest infiltration rate is the best soil for building a dam.

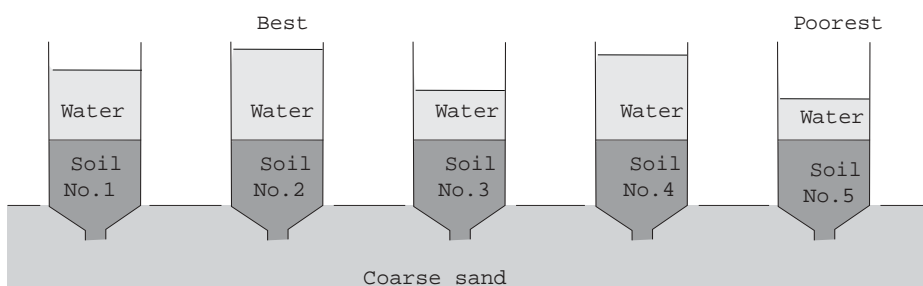

Figure 39: Testing soil samples for building a subsurface dam.

CONSTRUCTION

1 *The base for a dam wall*

This is cleared by removing all sand from the site in a stretch being about 2 metres wider than the base of the dam wall.

The width of the base is marked on the riverbed and excavated to a depth of 20 cm into the clay.

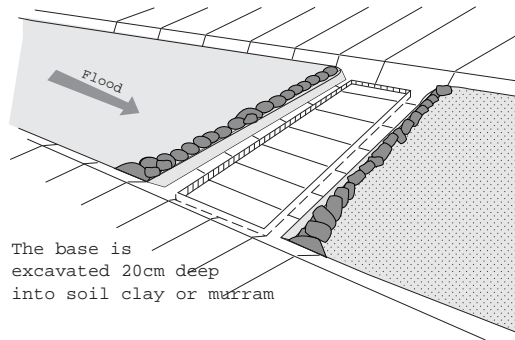

Figure 40: *Base for dam wall.*

The profile of the dam wall is marked onto the banks.

- 2 *A key*, 60 cm wide, is then excavated along the centre of the base and banks to a depth of 60 cm. Should layers of sand be found in the key the key must be deepened to 60 cm below any layer of sand.

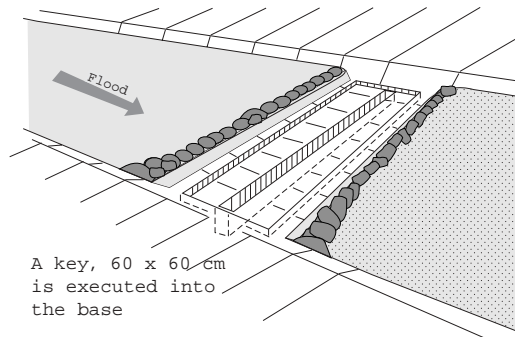

Figure 41: *Key in foundation.*

- 3 *The dam wall.* This is constructed of the best soil found on the site, which is excavated and cleaned of stones and organic matter.

The soil is compacted into the key, base and wall in layers of about 20 cm thickness. If water is scarce the soil can be compacted dry.

The upstream and downstream sides are cut to 45 degrees slope and made smooth with a wooden float. If the soil is sandy, the upstream side should be plastered with a 5 cm thick layer of clay.

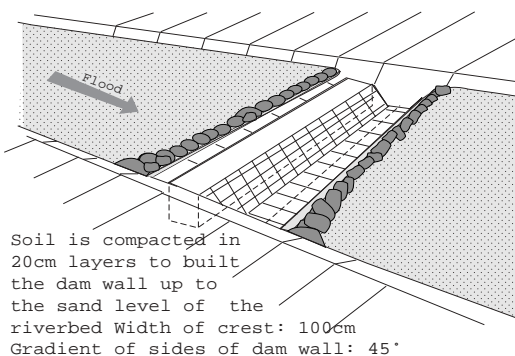

Figure 42: *Completed dam wall.*

OPERATION AND MAINTENANCE

Water is extracted from the deepest point of the reservoir by various means such as a waterhole, a hand-dug well, an intake chamber in the riverbed or an intake pipe with a well shaft built in the bank. Every type of extraction requires proper usage and maintenance. An operator should therefore be employed by the community to ensure its smooth operation.

A subsurface dam built of soil does not require any maintenance because it does not protrude above the sand level of a riverbed where floodwater could damage the dam wall.

5.5 A subsurface dam built of rubble stone masonry

By RELMA and ASALCON at Talek, Maasai Mara, in 1999.

CAPACITY USING THE EXAMPLE ON PAGE 14 AND 17.

Volume of sand reservoir	: 9,644 m ³ sand.
25% extractable water	: 2,411 m ³ water.
Cost of structure (exclusive of the value of community work)	: Ksh 75,700 = Ksh 31.40/m ³ water.
+ Cost of intake in bank	: Ksh 22,100 = Ksh 9.17/m ³ water.

Table 9: *Bill of quantity and cost.*

Item	Unit	Quantity	Unit cost Ksh	Total cost Ksh
Cement	50 kg bags	101 bags	500	50,500
Barbed wire	g. 12.5	40 kg.	90	3,600
Sand	Tonnes	15 tonnes	Community delivered	
Rubble stones	Tonnes	40 tonnes	Community delivered	
Total for materials				54,100
Artisans	2 masons	24 days	450	21,600
Labourers	4 persons	24 days	Community delivered	
Total for labour				21,600
Grand total, exclusive value of community work				75,700

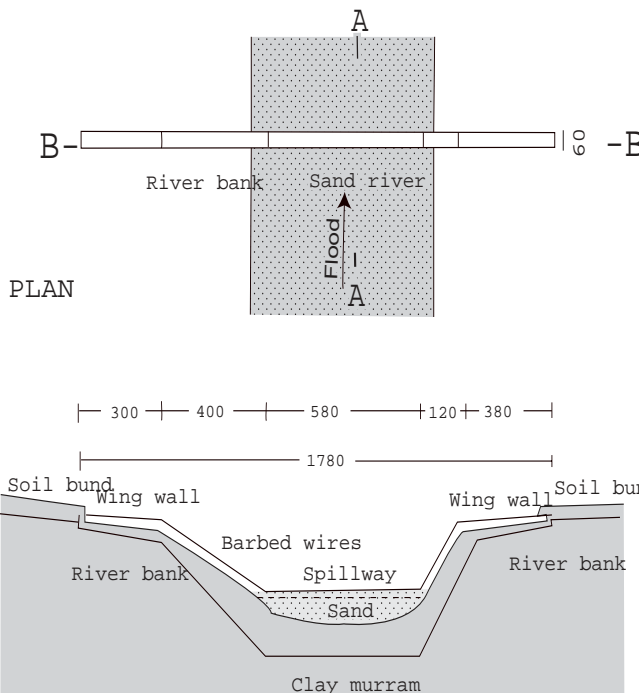

Figure 43: Design of a subsurface dam built of rubble stone masonry.

DESIGN CRITERIA

This type of subsurface dam is actually a low sand dam because its spillway extends 50 cm above the sand level in a riverbed. Should a dam wall require a height exceeding 50 cm above the sand level, then the design of the ALDEV sand dam (page 49) should be applied although it is more complicated. The following design criteria are considered;

1 Construction site

The construction site for a subsurface dam should be on an underground dyke of soil, clay or murrum found under the sand because;

- A natural dyke provides a natural water reservoir just upstream of the dyke.
- The sand on the dyke is shallowest therefore less costly and requiring less work to build a subsurface dam, and
- Water cannot hamper construction works on a dyke because it is the highest part of a sand river where the water will first subside.

Should an underground dyke not be found in a sand-river, a subsurface dam can be built cheaply of soil to test the yield of water from the sand reservoir created by the subsurface dam. If found viable, the reservoir could be enlarged by building a subsurface dam of rubble masonry or reinforced concrete between two walls of burnt bricks

2 *The dam wall*

The design for a dam wall is based on five factors:

- A subsurface dam must be equipped with a wing wall in each of its two riverbanks to prevent flash floods changing the flow of a sand river. Such flows could damage a subsurface dam.
- The height of the spillway must not exceed 50 cm above the sand level to prevent the dam wall from being pushed over.
- The depth of wing walls must be at least 60 cm into the banks and the depth of the wall in the banks and floor must be at least 100 cm in firm soil without any layer of sand.
- The width of the dam wall and its wing walls should be 60 cm.
- Reinforcement consists of four lengths of barbed wire, gauge 12.5, from one end of a wing wall to the other, about 20 cm from the bottom and another four lengths about 20 cm from the top of the wall.

CONSTRUCTION

- 1 *Excavation of a subsurface dam.* consists of digging a 60 cm wide trench. The depth should be 60 cm for the wing walls and 100 cm for the wall in the banks and floor. If a layer of sand is found in the trench, then it has to be deepened to 60 cm below the layer of sand.

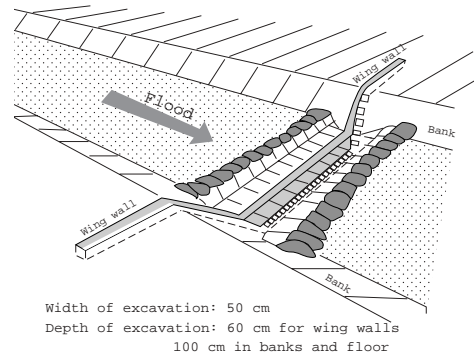

Figure 44: *Excavation for dam wall.*

- 2 *Construction of the dam and wing-walls.* Consists of compacting clean and moist rubble stones with mortar in the ratio of 1:4 in layers of about 20 cm high, all along the trench. Four lengths of barbed wire, gauge 12.5, are laid in the mortar on the first course of rubble stones for reinforcement. Another four lengths are laid about 20 cm from the top of the wall.

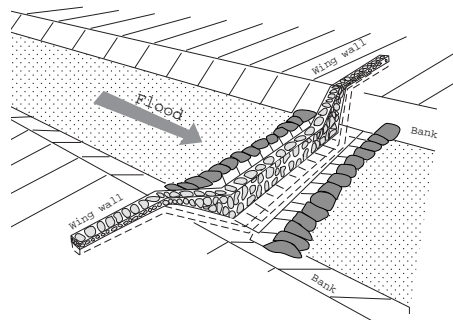

Figure 45: *Rubble stone masonry.*

- 3 The dam wall should protrude a maximum of 50 cm at the spillway and about 30 cm at the wing-walls. The wall above the river floor is built by setting large flat stones in the mortar along builders lines outlining the sides of the wall. The next day,

smaller stones are compacted with mortar between the stones outlining the wall. The exposed part of the dam wall is plastered with mortar in the ratio of 1:4 and sand is back-filled against the wall.

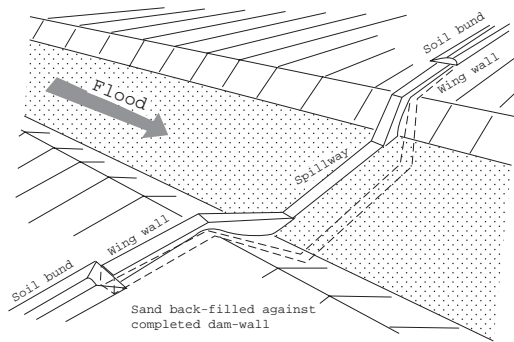

Figure 46: Completed dam wall.

OPERATION AND MAINTENANCE

The operation of a subsurface dam built of rubble masonry consists of extracting water from the deepest point of the reservoir. This is situated upstream of the dam wall which may be a waterhole, a hand-dug well or one of the intakes described earlier.

Whatever type of extraction is chosen, it requires proper usage and maintenance. An operator should therefore be employed by the community to ensure its smooth operation.

A subsurface dam built of rubble stone masonry does not require any maintenance when flash-floods have deposited sand to the level of the spillway because it does not protrude above the sand where floodwater could damage the dam wall.

5.6 A sand dam built of rubble masonry

Built by Danida & ASALCON at Kiwa Mwiitu, Wote, Kenya in 1996.

CAPACITY USING THE EXAMPLE ON PAGE 14 AND 17.

Volume of sand reservoir	: 26,868 m ³ sand.
25% extractable water	: 6,717 m ³ water.
Cost of structure exclusive of the value of community work	: Ksh 225,300 = Ksh 33.54/m ³ water
+ Cost of intake in bank	: Ksh 22,100 = Ksh 3.29/m ³ water

Table 10: Bill of quantity and cost.

Item	Unit	Quantity	Unit cost Ksh	Total cost Ksh
Cement	50 kg bags	300 bags	500	150,000
Piping	50 mm G.I.	6 metres	400	2,400
Piping	50 mm PVC	3 metres	100	300
Pipe fittings, tap, etc.				2,100
Tap stand	Steel manhole	1 unit	3,000	3,000
Sand	Tonnes	60 tonnes	Community delivered	
Rubble stones	Tonnes	200 tonnes	Community delivered	
Total for materials				157,800
Artisans	3 masons	50 days	450	67,500
Labourers	4 persons	50 days	Community delivered	
Total for labour				67,500
Grand total, excluding value of community work				225,300

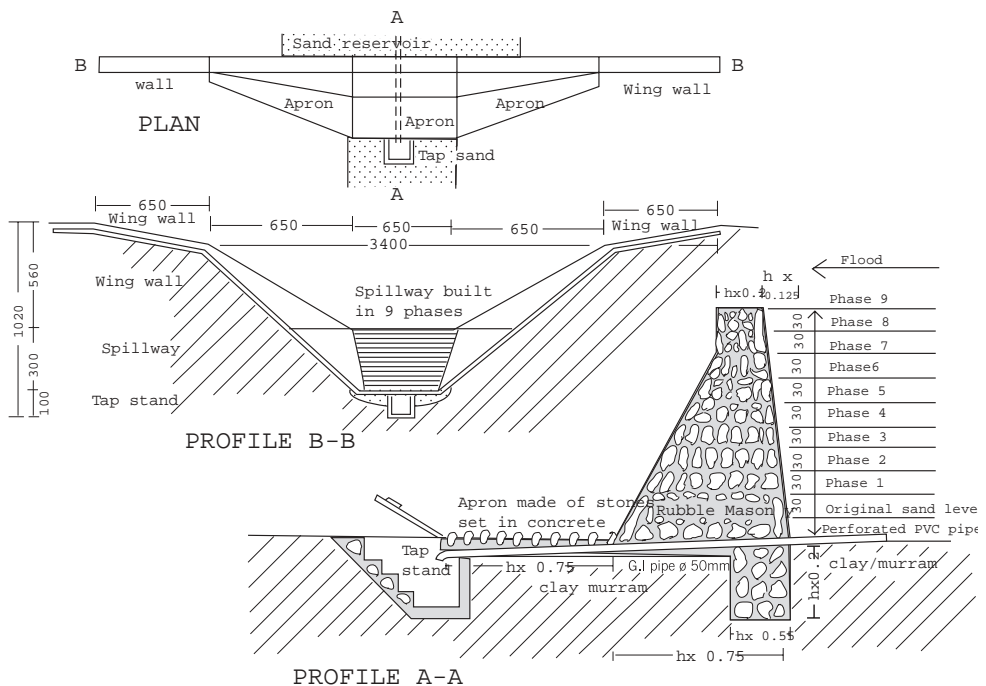

Figure 47: The ALDEV design of a sand dam built of rubble masonry.

DESIGN CRITERIA

Sand dams are much more complicated and costly to design and build than subsurface dams because of the pressure created by the elevated sand and water against the dam wall.

It is recommended that only persons with experience on subsurface dams should attempt to construct sand dams. Sadly enough, most of the sand dams not built according to the ALDEV design are non-functioning due to inexperienced designers and builders.

It is therefore recommended that a subsurface of soil or rubble stone masonry should be built before a sand dam is built to gain experience and to prove that a chosen reservoir will be water-tight and that flash-floods are sufficiently large to recharge the reservoir.

SITE CRITERIA

Sand dams are very site specific and should only be built where sand-rivers have the following aspects:

- Two equally high banks, where maximum flood levels cannot reach the top of the banks,
- Large and rocky catchments from where flash floods can transport sufficient volume of coarse sand to build up a sand reservoir to several metres height, and
- A reservoir which has proven watertight by means of waterholes or a subsurface dam.

DESIGN CRITERIA

The most successful design originates from the African Land Development (ALDEV) in Kitui, Kenya, which built some 40 sand dams in the 1950s, most of which are still supplying water. The design is based on gravity only with barbed wires in the key to withstand the forces of overtopping and sliding.

The spillway is raised in stages of 30 cm height to facilitate flash floods that would deposit coarse sand. Each stage is built after sand has been deposited to the level of that stage of the spillway.

Maximum height:	500 cm
Depth of key:	100 cm
Width of key:	Height x 0.25
Width of base:	Height x 0.75
Width of apron:	Height x 0.75
Width of crest:	Height x 0.20
Gradient of vertical front:	Height x 0.125
Length of vertical back-side:	Height x 0.125
Stages of raising spillway:	30 cm

CONSTRUCTION

1 *Width and depth of dam wall.*

The maximum height for a spillway is found by multiplying the highest flood level in the sand river by two. All other measurements depend on the height for the spillway. The width of the key, which is one quarter of the height of the spillway, is excavated to a depth of 100 cm along the upstream side of the dam wall. If a layer of sand is found in the key, it has to be deepened to 100 cm below that layer of sand. The key extends into both wing-walls with a depth of 100 cm in the banks and 60 cm on top of the banks.

The width of the base, which is three quarters of the height of the spillway, and the apron having a similar width, is excavated to a depth of 20 cm.

2 *Concreting the key and base*

This consists of compacting clean and moist rubble stones into concrete of ratio 1:4:4, each layer being about 20 cm high all along the key for the dam wall and its wing-walls. Four lengths of barbed wire, gauge 12.5, are laid on the first course of rubble stones for reinforcement. The key is filled up with rubble stones in mortar. The excavation for the base and apron are filled up with rubble stone masonry and a draw-off pipe of 2"

GI with a dented surface for good bonding is laid in its position. The surface of the apron is made very rough with stones protruding out of the surface to improve the bond to the following layers of rubble masonry.

3 Two templates, outlining the height and width of the dam wall and spillway are erected on the base. When builder's lines are drawn along the inner sides

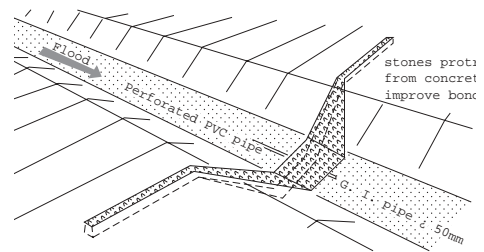

Figure 48: *Excavating key, base and wing walls.*

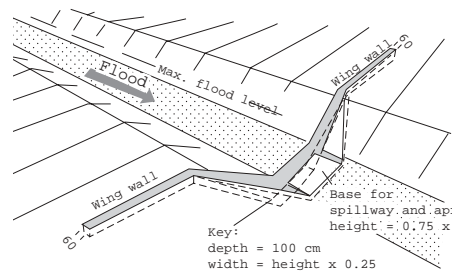

Figure 49: *Concreting key, base and wing walls.*

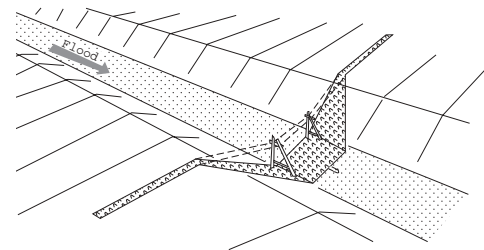

Figure 50: *Two templates outline the*

of the templates, they guide the builders constructing the dam.

- 4 The spillway must only be built in stages of 30 cm above the sand level of the riverbed to ensure the dam will trap coarse sand from where a maximum volume of water can be extracted. The dam wall and wing-walls are built onto their base by setting large flat rubble stones in mortar of ratio 1:4 along builder's lines. After a day of setting, smaller stones are compacted into concrete of ratio 1:4:4 between the lines of the large flat rubble stones. The wing walls are completed to a height of 20 cm above the banks, plastered and back-filled with soil.

A tap stand is built around the lower end of the draw-off pipe

and sealed with a lockable manhole of steel. An infiltration pipe is made of a two metre long and perforated 50 mm PVC pipe pushed over the upper end of the draw-off pipe. Pebbles and coarse sand are packed around the pipe.

- 5 The remaining stages of the spillway must be 30 cm height and only be built when flash floods have deposited sand up to the level of its present stage. Failure to do so will result in silt being deposited instead of coarse sand, thus reducing greatly reducing the supply of water that can be drawn from the dam.

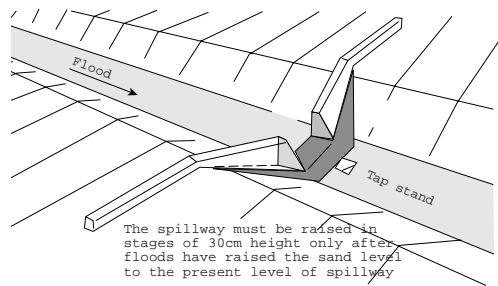

Figure 51: *The completed dam except for its spillway.*

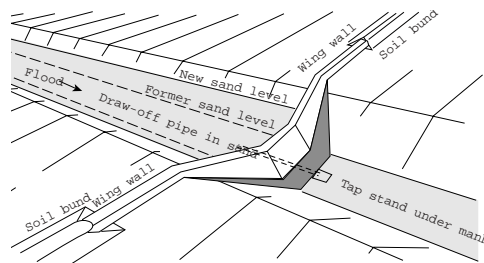

Figure 52: *The completed dam with its enlarged reservoir.*

OPERATION AND MAINTENANCE

Water for livestock and irrigation is drawn from a draw-off pipe with a tap stand covered with a lockable steel door, which is situated just downstream of the apron. Domestic water is drawn from a hand-dug well or intake at the deepest point of the sand reservoir.

An operator should be employed by the community to ensure a smooth operation of the tap stand and hand-dug well and also to carry out maintenance of the apron and wing-walls after flooding. An operator could be paid a salary by charging a small fee for water drawn from a sand dam.

6 CONSTRUCTION PROCEDURES

6.1 Mixing of mortar

- 1 Make a mixing platform of bricks, flat iron sheets, timber or a hard soil area by removing grass and loose soil.
- 2 Fill a bag of cement into a wheelbarrow and mark on the sides of it, the level to which the bag of cement fills in it.
- 3 Remove the cement from the wheelbarrow and fill it with sand to the mark. If the mixture of cement to sand is 1:4, then off-load four wheelbarrows filled with sand to the mark onto the mixing platform for every one bag of cement. Do not mix more mortar than can be used within one hour because that will weaken the mortar.
- 4 For the first time, turn the heap of sand and cement into another heap on the mixing platform but without adding water.
- 5 For the second time, turn the heap into another heap - still without water.
- 6 For the third time, turn the heap back to its original position - still without water.

- 7 For the fourth time, turn the heap back to its former position - still without water. These four turnings will have given the mixture a uniform grey colour, which is the sign of proper mixing.

The time has now come to add water, but please note, only to that part of the mixture which will be used within an hour. Do not add more water than absolutely necessary to make the mortar workable because the lower the water content, the higher its strength.

The remaining part of the mixture must stay dry, and under cover to avoid wind blowing the cement away. This should be so until it is mixed with water just before the mortar is to be applied.

- 8 The place where the mortar is to be applied must be sprinkled with water and the thickness of a coat of plaster should not exceed one centimetre for proper bonding. Where a thicker plaster is required, it has to be applied in several coats. After the plastering has been completed, it has to be cured under moist sacking for a couple of weeks.

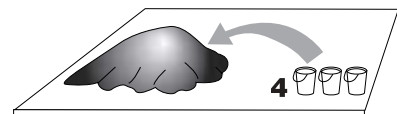
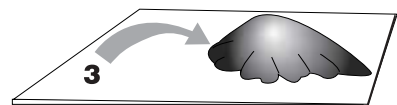
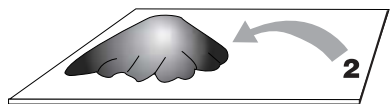
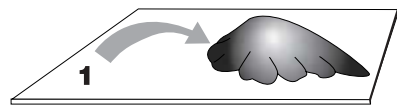
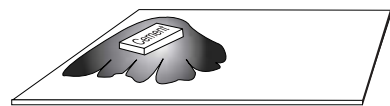

Figure 53: *Mixing of mortar*

6.2 Mixing of concrete

- 1) The first part of the procedure for mixing concrete is identical to mixing mortar without water as described under section 6.1 from (1) to (7). Since a larger volume may be required, the volume of sand and cement will be increased accordingly. Remember to avoid mixing more concrete than can be used within an hour.
- 2) Ballast (crushed stones) is filled to the mark in the wheelbarrow and the required number of loads off-loaded onto the heap of sand and cement which has been turned over four times without water.
- 3) Now pour water on the ballast laying over the sand-cement mixture, while simultaneously turning over all three components: sand, cement, ballast and water, to make concrete.

Do not add more water than is absolutely necessary to make the concrete workable, because the lower the water content, the higher its strength.

- 4) When the concrete has been laid out on its place, it has to be compacted with a tool made of a short length of thick timber nailed to a handle in order to get air bubbles out of the concrete.

Upon completing compaction and smoothening of the concrete, surface has to be cured under cover of moist sacking or polythene sheets for four weeks. If concrete is only cured for one week in the tropics, it will lose half its strength.

Table 11: *Typical concrete mixtures by volume.*

Cement		Sand		Ballast		Rubble stones	Use
1	:	3	:	4			Foundations, floors and beams for tanks.
1	:	3	:	6	:	6	Foundations for houses.
1	:	4	:	4	:	16	Rubble stone masonry
1	:	4	+	NIL (cement slurry)			Watertight plaster on rubble masonry.

Cement must be fresh and without lumps. Sand must be coarse and without dust or organic matter. Ballast can be made by breaking rocks and stones into small pieces; 4" to 1" sizes. Water must be without salt content.

6.3 Purchase of construction materials

Usually the price of construction materials varies from one hardware store to the other. The discount given by bargaining and cash payment also differs from dealer to dealer.

A good amount of money can often be saved by obtaining quotations on materials and their transportation to a construction site from at least three dealers.

When buying cement, the buyer should inspect the bags of cement and mark them to ensure that no hard lumps are found in the cement because that will render the cement useless for water projects.

The quality of sand is important when building water projects. Only coarse river sand with large particles should be used. Fine textured sand contains silt and should not be used either for mortar or concrete because it weakens the cement mixture and also shrinks thereby making fine cracks through which water can seep.

Stones used for ballast or rubble stone masonry must be of hard rock, which cannot be broken except by hammers. Sediment rocks and stones which can be broken by hands are unsuitable.

Waterproofing cement dries up too quickly in the tropics, which results in cracking of the plaster that should be watertight. A better solution is to mix cement into water until a consistency of porridge is reached. This is called NIL and is applied with a square steel trowel to a wall that had been plastered that same day.

Water for construction works must not be salty because that will corrode the reinforcement placed in mortar and concrete.

6.4 Hiring a contractor

The craftsmanship of a contractor and his artisans is a vital component of building water supply systems. All too often, a good design and costly materials have been spoiled by builders who do not understand the value of proper mixing of cement with aggregate and sufficient curing of mortar and concrete works.

When hiring a contractor or builders, it is important to inspect some of the construction works they have completed in order to find out whether the builders are the experts they always claim to be. If their works and fees are found to be of acceptable standard,

they can be given a contract provided they follow the instructions given in this handbook, including the procedures for mixing mortar and concrete.

Builders normally get 10% advance payment of the contract on the very day they start working at a construction site. All too often a builder has been seen disappearing with a bigger advance without having done any work. On large building works, the final payment is not done until a few months after completion. This gives time for the work to be checked for any faults.

7 REFERENCES

- Fewster, E. 1999. *The feasibility of Sand Dams in Turkana District, Kenya*. Loughborough University, UK.
- Gould, J. and Nissen-Petersen, E. 1999. *Rainwater Catchment Systems*. IT Publications, UK.
- Graves, T. 1980. *Dowsing*. Granada Publications, Ireland.
- Hudson N.W. 1975. *Field engineering for agricultural development*. Oxford, UK.
- Longland, F. 1938. *Field Engineering*. Tanganyika.
- Nilsson, Å. 1988. *Groundwater Dams for small-scale water supply*. IT Publications, UK.
- Nissen-Petersen, E. 1982. *Rain Catchment and Water Supply in Rural Africa*. Hodder & Stoughton, UK.
- Nissen-Petersen, E. 1990. *Harvesting rainwater in semi-arid Africa*. Manual No. 4. Shallow Wells with Bucket-lift and Manual No. 5. *and Subsurface and Sand-storage Dams*. Danida, Kenya.
- Nissen-Petersen, E. 1995. *Subsurface & Sand-storage Dams*. UNDP/Africare, Tanzania. (Unpublished).
- Nissen-Petersen, E. 1996. *Ground Water Dams in Sand-rivers*. UNDP/UNCHS, Myanmar (Burma).
- Nissen-Petersen, E. 1995 to 1999. *Reports on training courses on sand-river development in Wote, Tharaka, Kibwezi, Trans-Mara, Kendu Bay and Turkana, Kenya*.
- Nissen-Petersen, J. and Hamid Omer Ali. 1995. *Manual on rehabilitation of open wells*. Kruger Consult/Danish Red Cross, Denmark.
- Sandstrom, K. 1997. *Ephemeral rivers in the tropics*. Linköping University, Sweden.
- Stern, P. 1990. *Field Engineering*. IT Publications, UK.
- Stulz, R. & Mukerji, K. 1993. *Appropriate Building Materials*. SKAT/IT/GATE, UK.
- Wiplinger, O. 1958. *The storage of water in sand*. Water Affairs, South West Africa.

The Swedish Development Cooperation Agency (Sida) has supported rural development programmes in Eastern Africa since the 1960s. It recognises that conservation of soil, water and vegetation must form the basis for sustainable utilisation of land and increased production of food, fuel and wood.

In January 1998, Sida inaugurated the Regional Land Management Unit (RELMA) based in Nairobi. RELMA is the successor of the Regional Soil Conservation Unit (RSCU), which had been facilitating soil conservation and agroforestry programmes in the region since 1982. RELMA's mandate is to contribute towards improved livelihoods and enhanced food security among small-scale land users in the region, and the geographical area covered remains the same as previously, namely, Eritrea, Ethiopia, Kenya, Tanzania, Uganda and Zambia. RELMA's objective is to increase technical know-how and institutional competence in the land-management field both in Sida-supported programmes and in those carried out under the auspices of other organisations.

RELMA organises training courses, workshops and study tours, gives technical advice, facilitates exchange of expertise, and initiates pilot activities for the development of new knowledge, techniques and approaches to practical land management.

To publicise the experiences gained from its activities in the region, RELMA publishes and distributes various reports, training materials and a series of technical handbooks.

About this book:

Sand rivers, also called dry riverbeds, transport rainwater run-off from highlands to the sea through the most dry parts of this planet where water is very scarce. Although flood water may be drawn from the sand in some riverbeds for a short period of time after floods, the big majority of sand rivers are dry throughout the years.

This book explains in simple terms how dry riverbeds can be changed into water sources for long periods after floods - and in some cases throughout the years. The usual problems of contamination and evaporation in hot climates are almost eliminated due the water being trapped and stored underground between the sand particles of riverbeds. This book is based on the author's practical experience on developing affordable water supply systems in some of the driest parts of Africa and Asia over the last 25 years.

ISBN 9966-896-53-8



RELMA

Regional Land Management Unit, RELMA/Sida, ICRAF Building, Gigiri, P. O. Box 63403, Nairobi, Kenya
TEL: (+254 2) 52 14 50 Ext. 4418, 52 25 75, FAX: (+254 2) 52 07 62, E-mail: relma@cgiar.org
Internet: www.relma.org