

# Water Lifting

Erich Baumann



# Water Lifting

Erich Baumann

First edition: 2000, 1000 copies

Author: Erich Baumann

Published by: SKAT, Swiss Centre for Development Cooperation  
in Technology and Management

Copyright: © SKAT, 2000

Comments: Please send any comments concerning this publication to:

SKAT  
Vadianstrasse 42  
CH-9000 St.Gallen, Switzerland

Tel: +41 71 228 54 54

Fax: +41 71 228 54 55

e-mail: [info@skat.ch](mailto:info@skat.ch)

Printed by: Niedermann Druck, St.Gallen, Switzerland

ISBN: 3-908001-99-4

### ***Context***

Access to adequate water, sanitation, drainage and solid waste disposal are four inter-related basic needs which impact significantly on socio-economic development and quality of life. The number of people around the world who still do not have access to these basic facilities, despite enormous global effort over more than two decades, provides sufficient evidence that conventional approaches and solutions alone are unable to make a sufficient dent in the service backlog which still exists. Numerous initiatives are ongoing at different levels to improve strategies, technologies, institutional arrangements, socio-cultural anchorage, and cost effectiveness, all to enhance efficiency and, eventually, to have an impact on the sector's goals. In addition, the ever-increasing scarcity of water brings policymakers together to find solutions to the challenge of water resource management. This series of manuals is intended as a contribution to these efforts.

### ***Background***

The decision to produce this series of manual was prompted by the positive experience gained with a practical manual based on the experience of Helvetas (a Swiss NGO) during the 1970s in Cameroon, which has become outdated with the passage of time. SDC (the Swiss Agency for Development and Co-operation) supported SKAT's initiative to produce this series, working with professionals with longstanding practical experience in the implementation of rural water supply projects. Lessons learnt during the workshops held by AGUASAN (an interdisciplinary working group of water and sanitation professionals from Swiss development and research organisations) over the last 14 years have been included where appropriate. In particular, there is an emphasis on documenting and illustrating practical experiences from all regions of the world.

### ***The Manuals***

As can be seen from the table below, this series of manuals is primarily aimed at project managers, engineers and technicians. However, given the wide range of subjects covered, it is also an important working tool for all actors in the sector, ranging from those involved with policy development to those constructing systems at village level. The series has a clear focus on water supply in rural settings. It proposes technologies with due consideration for socio-cultural, economic, institutional and regulatory requirements. This approach is in keeping with the SDC water and sanitation policy, emphasising the balanced development approach leading to sustainable programmes and projects.

It should be noted that the present series deals almost exclusively with water supply. The importance of sanitation is however clearly established in Volume 1, which deals predominantly with the software aspects necessary to achieve an impact. It includes some proposals for optional tools, approaches and institutional arrangements and is intended as an overall introduction to the other, more technical, volumes of the series.

### ***Some final comments***

The water and sanitation sector is constantly evolving. We would welcome any queries, comments or suggestions you might have. Your feedback will be made available to other interested users of the manuals.

Finally, we hope that these manuals will be useful for the practitioner in the field as well as for the planner in the office. If the series can be a contribution to providing water to more people in need on a sustainable basis, we will have achieved our goal.

The production of this series has only been possible through the continuous support of colleagues from all over the world. Our sincere thanks to all of them.

Armon Hartmann  
Head of Water & Infrastructure Division  
Swiss Agency for Development Co-operation

Karl Wehrle  
Head of Water & Construction Division  
SKAT

I am most grateful to the Water and Infrastructure Division, SDC who funded this work; particularly to Armon Hartmann who encouraged the HTN over all the years with support and council.

I would like to record my thanks to my colleagues and good friends in the HTN Network whose input has been invaluable in arriving at the conclusions reached in this booklet. Special thanks go to Arun Mudgal who worked very closely with me over many years on technology promotion. Many of his ideas and views have found their way into the text. His advice and review of the manuscript helped to eliminate errors and misquotes.

The completion of this book was made possible thanks to the assistance from Karl Erpf and Catherine Ndiaye of SKAT. Karl did most of the drawings and Catherine prepared the lay out. Finally, I thank my wife, Ronagh for her critical review and for changing my words and thoughts into grammatically correct language.

# Contents

<b>1.</b>	<b><i>Introduction</i></b> .....	<b>1</b>
1.1	<i>HTN</i> .....	1
<b>2.</b>	<b><i>Pumps and water lifting techniques</i></b> .....	<b>3</b>
2.1	<i>Principles for lifting water</i> .....	3
2.2	<i>Pump types</i> .....	4
2.2.1	Reciprocating pumps .....	4
2.2.2	Suction and lift pumps .....	4
2.2.3	Diaphragm pumps .....	6
2.2.4	Progressive cavity (mono) pumps .....	6
2.3	<i>Materials for pumps</i> .....	7
2.4	<i>Selection criteria for handpumps</i> .....	7
2.4.1	Operating conditions .....	7
2.4.2	Other criteria .....	7
<b>3.</b>	<b><i>Choice of technology</i></b> .....	<b>9</b>
3.1	<i>Groundwater sources</i> .....	9
3.1.1	Hand-dug well .....	12
3.1.2	Hand-drilled borehole .....	14
3.1.3	Machine drilled borehole .....	16
3.2	<i>Pumping technologies</i> .....	18
3.2.1	Suction hand pumps .....	18
3.2.2	Direct Action handpumps .....	20
3.2.3	Deep well handpumps .....	22
3.2.4	Electrically driven power pumps .....	24
3.2.5	Diesel driven mechanised pumps .....	26
3.2.6	Solar powered mechanised pumps .....	28
3.2.7	Wind powered pumps .....	30
<b>4.</b>	<b><i>Typical cost for small water supply systems</i></b> .....	<b>33</b>
4.1	<i>Hand-dug wells, Hand-drilled boreholes,</i> .....	33
4.2	<i>Boreholes (high- or low-yielding, small or big diameter),</i> .....	33
4.3	<i>Computer supported cost calculation programme</i> .....	35
<b>5.</b>	<b><i>Institutional framework</i></b> .....	<b>39</b>
5.1	<i>Role of stakeholders</i> .....	39
5.1.1	National level .....	39
5.1.2	Rural water authorities at district level .....	39
5.1.3	Role of communities .....	41
5.1.4	Role of ESA projects .....	41
5.2	<i>Extension services</i> .....	41

<b>6.</b>	<b><i>Standardisation and private sector support</i></b> .....	<b>43</b>
6.1	<i>Standardisation</i> .....	43
6.2	<i>Pre-qualification of suppliers</i> .....	44
6.3	<i>Manufacture of handpumps</i> .....	44
6.3.1	Cost of local production .....	45
6.4	<i>Procurement channels of handpumps</i> .....	46
6.5	<i>Quality control</i> .....	46
<b>7.</b>	<b><i>Operation and Maintenance</i></b> .....	<b>49</b>
7.1	<i>Community management of O&amp;M</i> .....	49
7.1.1	Building village level structures .....	49
7.1.2	Restructuring government departments .....	50
7.2	<i>O&amp;M - costs and strategies</i> .....	50
7.2.1	Cost of maintenance .....	51
7.2.2	O&M strategy .....	51
7.3	<i>Private sector involvement in O&amp;M</i> .....	52
7.4	<i>Spare parts distribution</i> .....	52
<b>8.</b>	<b><i>India handpump case study</i></b> .....	<b>55</b>
8.1	<i>Introduction</i> .....	55
8.2	<i>The India MKII success story</i> .....	55
8.2.1	Emergence of a new pump .....	55
8.2.2	Large-scale production .....	56
8.2.3	Standardisation .....	57
8.2.4	The India MKII in the export market .....	58
8.2.5	Accomplishing quality .....	59
8.2.6	Government's role .....	59
8.3	<i>Technology development for change</i> .....	59
8.3.1	Involving the users .....	59
8.3.2	The India MKIII development .....	60
8.3.3	The rationale behind the India MKIII development .....	60
8.4	<i>Changing course</i> .....	61
8.4.1	Has the MKIII been a step in the right direction? .....	61
8.5	<i>Maintaining the assets</i> .....	62
8.5.1	Relevance of handpump programme .....	62
8.5.2	The three-tier system .....	62
8.5.3	Practical experience .....	62
8.5.4	Community based handpump maintenance .....	63
<b>9.</b>	<b><i>Handpump fact-sheets</i></b> .....	<b>65</b>
9.1	<i>No 6 Pump</i> .....	66
9.2	<i>Jibon Pump</i> .....	67
9.3	<i>TARA Pump</i> .....	68
9.4	<i>NIRA AF85 Pump</i> .....	69
9.5	<i>MALDA Pump</i> .....	70

9.6	INDIA Mark II Pump .....	71
9.7	INDIA Mark III Pump .....	72
9.8	AFRIDEV Pump .....	73
9.9	U3M Pump .....	74
9.10	VERGNET Pump .....	75
9.11	VOLANTA Pump .....	76
9.12	BUSH Pump .....	77
9.13	Rope Pump.....	78



***List of abbreviations used***

AC	Alternate Current
ARWSP	Accelerated Rural Water Supply Programme
BIS	Bureau of Indian Standards
CBHM	Community Based Handpump Maintenance
CPHEEO	Central Public Health and Environmental Engineering Organisation
DC	Direct Current
DCD	Department for Community Development
DRA	Demand Responsive Approach
DTH	Down-the-Hole Drilling
ESA	External Support Agency
FOB	Free on Board
FRP	Fibre Reinforced Plastic
GI	Galvanised Iron
GOI	Government of India
HDPE	High Density Poly Ethylene (plastic)
HTN	Network for Cost-effective Technologies in Water and Sanitation
INR	Indian Rupee
ISI	Indian Standard Institution
lpcd	Litre per Capita and Day
MERADO	Mechanical Engineering and Research Organisation
MNP	Minimum Needs Programme
MOH	Ministry of Health
MOW	Ministry of Water
MS	Mild Steel
NGO	Non Government Organisation
O&M	Operation and Maintenance
PHED	Public Health Engineering Department
PV	Photo Voltaic
PVC	Polyvinyl Chloride (plastic)
R&D	Research and Development
RGNDWM	Rajiv Gandhi National Drinking Water Mission
RWSS	Rural Water Supply and Sanitation
SDC	Swiss Agency for Development and Cooperation
SS	Stainless Steel
SWL	Static Water Level
VLOM	Village Level Operation and Management of maintenance
VWSC	Village Water and Sanitation Committee
WES	Water and Environmental Sanitation
/cap	Per capita

# 1. Introduction

Sustained safe drinking water supply and sanitation facilities are essential to improve the living conditions of the rural population. The provision of safe water helps to combat water borne diseases and improves community health in general. Thus, it is an essential component of poverty alleviation. Experience has shown that sustainability of water and sanitation facilities can be greatly enhanced when the users have a voice in the decision-making processes of their projects. In view of this fact, top-down planning is now normally replaced by a joint planning in which the central government authorities set the overall framework, the policies and the processes. The district level authorities plan and organise the execution of the infrastructure development work and the village communities are involved in the detailed planning of their facilities. They participate in the choice of technology and they need to be given both the capability and the responsibility for the operation and maintenance of their water points.

In a demand responsive approach (DRA), user communities decide on how they participate in the construction of water and sanitation facilities. The final choice of technology rests with them, they decide what type of water supply and sanitation system they want, can afford, and can maintain. The individual community's choice of technology is normally guided by its own sense of need and by the affordability of its contribution towards the investment cost. Since the village is responsible for the management of its water supply facility, it must take into consideration costs for operation, routine maintenance and major repairs or replacements as well as the reliability of the system. To arrive at a sensible choice it is necessary that the community is aware of the technical, financial and institutional implications of its technology choice. Information on the different options (point sources or piped systems) in an easy to read format can be of great help to user groups in decision making. This publication is prepared with substantial inputs from HTN - The global Network for Cost-effective

Technologies in Water and Sanitation - to meet this requirement.

## 1.1 HTN

HTN promotes affordable technologies for the poor. Established in 1993, with its secretariat at SKAT, Switzerland, HTN pursues the technology promotion achievements of the 1981-1990 International Drinking Water and Sanitation Decade. Operating on a modest budget with funds largely provided by the Swiss Agency for Development and Cooperation (SDC), HTN has created a niche, primarily in handpump technology, and has contributed significantly to the development of field-proven, reliable and easy-to-maintain designs. Although HTN's focus continues to be the handpump, its scope now embraces household water treatment technology, water quality field test kits, drilling and environmental sanitation.



### *Mission Statement*

- HTN believes that access to basic water and sanitation services is a fundamental right and essential for human development and poverty reduction.
- HTN aims to facilitate the provision of safe water and sanitation to the poor and deprived through the promotion of sustainable technologies that are affordable and responsive to the needs of the users, as symbolised by the handpump.
- HTN strives to achieve this goal in partnership, through networking and alliance building.
- HTN aspires to be a catalyst for capacity building, mutual learning, knowledge sharing and the documentation of experiences.

## ***Water Lifting***

HTN is technically oriented, blending a strong engineering background with institutional, financial and social principles. It is a focal point for research, development and standardisation of low cost water supply and sanitation technologies. It places results and findings of this work in the public domain through the production of publications, international specifications and manuals for quality control, installation and maintenance.

HTN functions as a resource centre, which pools diverse experience and expertise through its members. HTN provides demand-based support to sector partners and shares information through workshops, publications, consultancies and a website. HTN's approach of equitable sharing of knowledge helps to bring water to the World's least served people and places the technology in their hands.

## 2. Pumps and water lifting techniques

In order to keep the size of this publication within reasonable limits this more theoretical chapter is kept rather short. Interested readers are advised to contact HTN/SKAT for more in-depth information and specific literature.

### 2.1 Principles for lifting water

Using any one of the following mechanical principles can lift water. Pumps may use one or sometimes a combination of these principles.

#### a Direct lift

Water is physically lifted in a container.

*Typical examples are:*

Rope and Bucket, Bailer, Persian Wheel

#### b Displacement

Because water can not be compressed it can be pushed or displaced.

*Typical examples are:*

Piston Pumps, Progressive Cavity Pumps, and Diaphragm Pumps

#### c Creating a velocity head

Water can be propelled to a high speed. The momentum produced can be used either to create a pressure or a flow.

*Typical examples are:*

Propeller Pumps, Centrifugal Pumps, Rebound Inertia Pumps, Jet Pumps

#### d Using the buoyancy of a gas

Air that is blown into water which bubbles upward. It will lift a proportion of the water that it flows through.

*Typical examples are:* Air lift

#### e Gravity

Energy of a media (water) that flows downward under gravity is used to lift water.

*Typical examples are:* Siphons

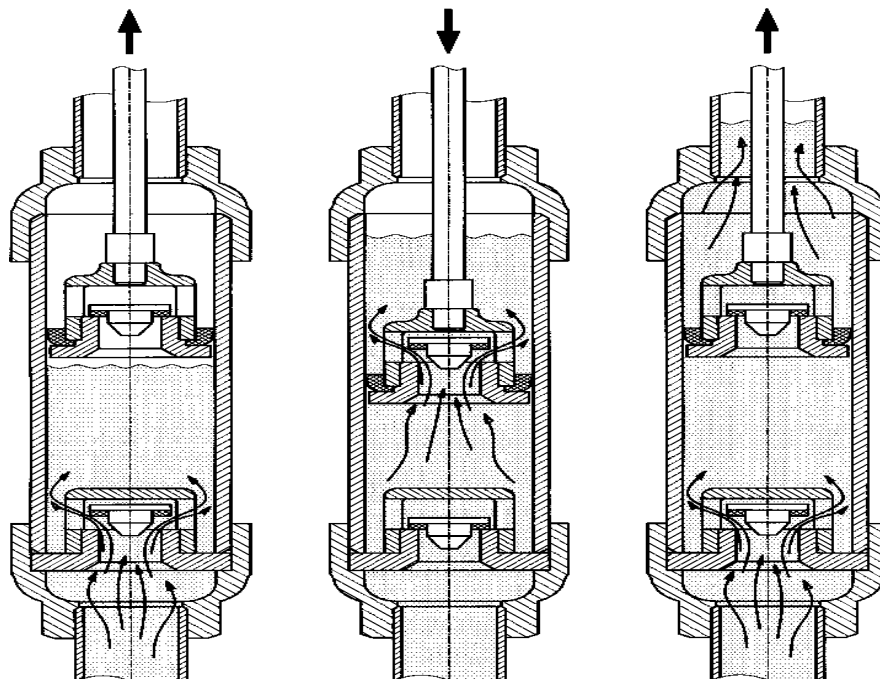

Figure 1 Pumping principle

## 2.2 Pump types

### 2.2.1 Reciprocating pumps

The most common reciprocating pumps are the piston pumps. The majority of handpumps used in rural water supply and sanitation (RWSS) are of this design.

The functioning of reciprocating pumps is caused by the principle that water flows from areas of high pressure to areas of low pressure. The reciprocating pumps create an area of sufficiently low pressure above the body of water, thus causing it to flow upward.

A reciprocating piston pump consists essentially of a long vertical pipe, called rising main. This rising main extends into the cylinder (the area in which the piston/plunger moves up and down). Near the bottom of the cylinder, a non-return valve is fitted, called footvalve. The footvalve allows the water to flow from the lower part of the pump into the cylinder, but prevent it from flowing back into the well. A second non-return valve is situated in the piston/plunger. The piston/plunger and the footvalve will alternatively divide the pump into an upper part or a lower part. The lower part of the pump always extends into water body of the well.

When the operator lowers the piston, the atmospheric pressure acts equally on all water surfaces. The footvalve stays closed preventing water from being pushed back into the well. The non-return piston valve opens allowing water to flow through the piston. The piston presses down on to the water until it gushes up through the valve in the piston.

At the lowest point of the stroke, the movement of the piston is reverted. The pressure of the water column above the piston causes the piston valve to close. This effects two things:

- (a) The water above the piston starts rising. It can not flow backwards and will rise in the rising main until it reaches the top of the pump; flowing out by the spout, and
- (b) Because the piston stops pressing on the water below it, the pressure in the lower part of the cylinder drops; a vacuum is created. The water in the well is still under atmospheric pressure and will push its way past the footvalve into the cylinder.

### 2.2.2 Suction and lift pumps

Reciprocating pumps are of two types; namely suction- and lift pumps. In theory, both suction- and lift pumps are the same. The operating principles of the reciprocating pump apply to both of them. The difference between the two pumps is the position of the cylinder in relation to the water level.

#### Suction pumps

In a "suction" pump, the cylinder is above the water table, usually near the top of the pump in the pump head. The rising main extends below the water table. When the pump is operated, during the upwards stroke it appears that water gets "sucked up" through the rising main into the cylinder. In fact, the atmospheric pressure forces the water into the area of low pressure underneath the piston. The theoretical limit to which the atmospheric pressure can push up water is 10 metres. In practice, suction pumps can be used to lift water up to about 7-8 metres.

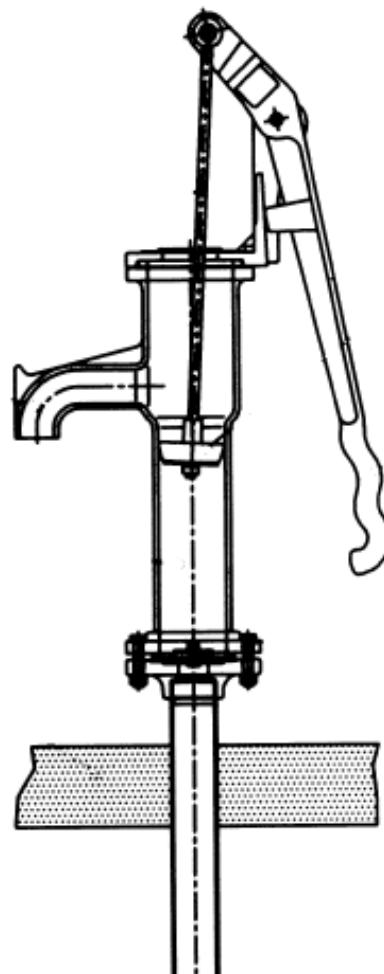

Figure 2 Suction pump

A suction pump needs to be full of water before it can operate. That means pumps need to be primed. In regular practice, water has to be poured into the pump by the operator every time the pump is emptied by a leaking footvalve. Thus, the danger exists that the well can be contaminated through polluted water used for priming.

The advantage of suction pumps is that the cylinder is normally above the level of the soil. Maintenance tasks (replacement of seals and valves) can be easily performed with few tools.

### ***Lift Pumps***

In a "lift" pump, the cylinder is located below the water table. The rising main above the cylinder always forms part of the upper part of the pump. Any

water in the pump, which is above the water table, is pushed upwards or "lifted". It rises to the level of the spout. With each stroke, the amount of water displaced by the piston is pushed out on the top.

Lift pumps theoretically have no depth limit to which they can be used. In practice (for handpump), the limitations are given by the power a human being can exert. Pumping 10 lt./min from 60 - 80 metres requires about 150 - 180 watt power input. This is very hard work and tiresome. Normally pumps for such depth need to have handles that allow more than one person operating.

Because the cylinder has to be located below the water table the pump rod has to reach down to the cylinder as well. That means long, heavy pump rods that make maintenance much more complicated than with suction pumps. An „open-top“ cylinder configuration (i.e. the rising main diameter is bigger than the cylinder diameter) allows that the piston and footvalve can be removed without dismantling the rising main. This makes maintenance procedures considerably simpler. However, it is more expensive as larger diameter and heavier rising main pipes are used.

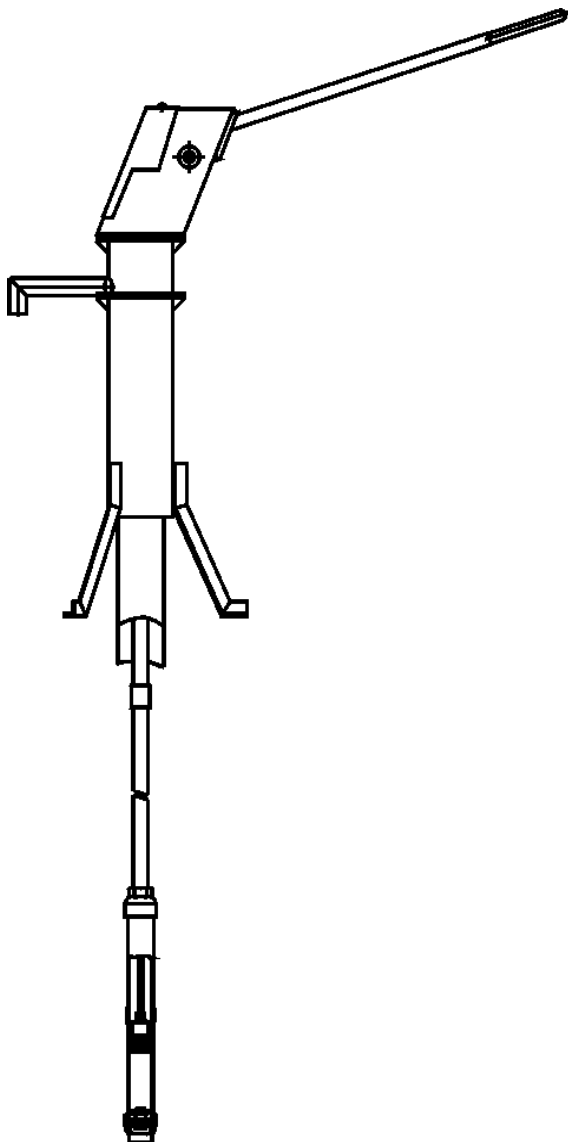

**Figure 3**     *Lift pump*

### 2.2.3 Diaphragm pumps

An alternative to the use of a piston is to create a pump in which a flexible diaphragm is moved up and down thus displacing water. A typical example of such a diaphragm pump is the Vergnet pump described in [chapter 9](#), Handpump Fact Sheets.

The advantages of diaphragm pumps are that they are easy to install, since no heavy mechanical parts are used. They can also be made corrosion resistant through use of plastic hoses instead of rising mains. The disadvantages are that they need high quality rubber diaphragms that are costly, and they have a relatively low efficiency because of the deformation work needed to expand the diaphragm. Further, the working principle is relatively complicated and not so easy to understand. Thus, training of mechanics and caretakers is essential.

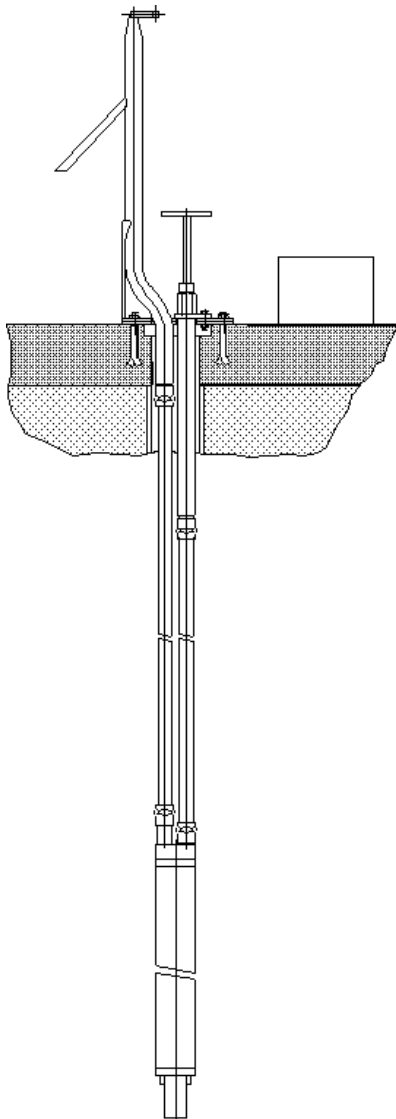

Figure 4 Diaphragm pump

### 2.2.4 Progressive cavity (mono) pumps

Contrary to most rotary positive displacement pumps, progressive cavity pumps can be used in small diameter boreholes. The pump consists of a single helix rotor inserted into a double helix stator. The rotor helix is made to a high finish; i.e. chromium plated steel or polished stainless steel (SS). It is circular in cross section so that it fits exactly into one of the two helices of the stator. As a result, the empty second helix of the stator is divided into a number of separated voids. When the rotor is turned, these voids are screwed along the axis of rotation. In the well water will be trapped in the voids and when the rotor is rotated these volumes are pushed upwards and discharged into the rising main.

Progressive cavity pumps need to be driven at a relatively high speed; therefore, handpumps are often fitted with a gearbox. This makes this type of pump relatively complicated and costly.

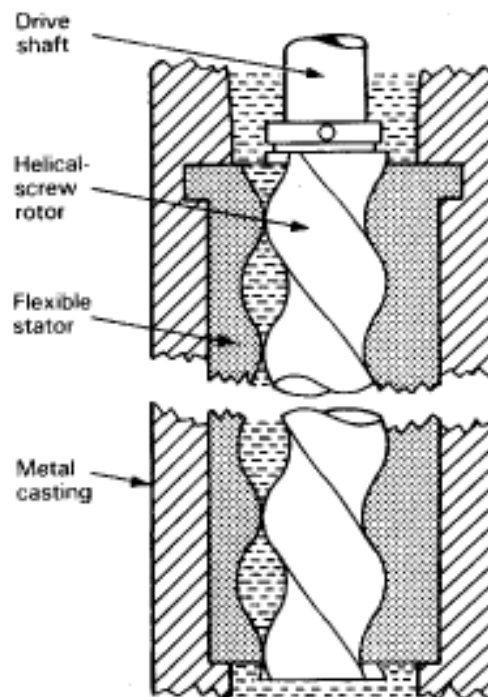

Figure 5 Progressive cavity principle

## 2.3 *Materials for pumps*

Traditionally, cast-iron was the main material for the construction of pumps. In the last decades, the design of handpumps and submersible pumps has changed and the use of cast-iron has been greatly reduced.

Modern pumps need to function for long period of time without breakdown. Therefore, the materials need to be strong and stress resistant with a high abrasion resistance. Unfortunately, groundwater is often aggressive; therefore, corrosion is a constant problem for pumps. Hot dip galvanising or plating of mild steel components does not offer adequate corrosion protection in water that has a low pH value. Stainless steel (SS) offers a material alternative that is both very strong and corrosion resistant. The big disadvantage however, is the high cost of this material. For low cost technologies, the initial cost of a pumping device becomes increasingly important (communities have to pay part of the initial installation cost). Therefore, although SS can sometimes be the best and probably the most economical solution, the high capital cost prevents its use.

The development of plastic materials and the emergence of a plastic industry in Third World countries opened new dimensions for designers. Despite the progress made with the application of plastic materials there is still a need for research and development (R&D). Engineering plastics with an e-modulus and a tensile strength similar to steel are also expensive. However rising mains, pump rods, and bearings are increasingly made of plastic materials that are common, such as PVC, HDPE and FRP.

## 2.4 *Selection criteria for handpumps*

The conditions under which the pumps are used determine largely the selection of the handpump type used. In general, the critical factors for a selection of a handpump are:

- (a) Size of User Group
- (b) Lift (Shallow or Deep Well Applications)
- (c) Ground Water conditions (corrosion)
- (d) Development or Emergency situations

### 2.4.1 *Operating conditions*

As a rule of thumb it can be said that the stress on a pump is a function of number of users and pumping lift, with both factors increasing exponentially.

$$\text{Stress} \approx f_x (\text{Nos. of users})^2 \times (\text{Pumping lift})^2$$

That means that the number of users and the pumping lift are the most important factors.

In areas with aggressive groundwater, it is absolutely essential to make sure that pumps are corrosion resistant.

#### *User group*

Some pumps were designed as a family pump with the objectives to serve small user groups. These pumps are generally simple and cheap. However, as soon as they are used for large user groups, they are not robust enough. Therefore, when the user groups are large (> 100) it is essential to use stronger pumps that are designed to serve more people.

#### *Pumping lift*

For different applications, the most appropriate pumps vary. Shallow well applications allow simple suction pumps or direct action pumps. However, they can only be used to a pumping lift of maximum 7 metres respectively and 15 metres (installation depth of 16.5 metres) respectively.

Deep well pumps can cover the complete range of installations, but they are very expensive solutions on boreholes with a high watertable.

### 2.4.2 *Other criteria*

#### *International specification*

Standardised technologies normally have information in the public domain. This permits the use of technology without any restriction. Standardisation approaches allow that all "concerned" (governments, privates industries and users) can get familiar with and adapt to the technology. The results are that prices come down and local capacity is generated.



## ***Water Lifting***

As designs are standardised, it is possible to compare cost and quality of locally made or imported pumps with identical products available in the international market, and it is possible to substitute a pump with an identical product from another source. Spare parts for standardised pumps are interchangeable irrespective of the suppliers, which makes the organisation of spare parts distribution much easier.

### ***Ease of repair and installation***

Pumps that can be installed quickly with a minimum of tools are advantageous. If the basic repairs (replacing seals, replacing bearings, removing of piston and footvalve) are simple to perform, village mechanics can maintain the pump themselves. Heavy and complex tooling makes motorised central maintenance teams necessary. This affects the cost of repairs and the time that the pump is out of service.

### ***Reliability***

The frequency of breakdowns is very important; Villagers will accept only pumps that give a satisfactory service for a long period. Reliability of mechanical equipment is commonly measured in "Mean Time before Failure". This aspect is very important as the communities learn to appreciate the value of a safe water supply when the pump is working for a prolonged period without problems.

In rural water supply however, "Mean Down Time" is also significant. A pump that can be repaired at village level might be back in service within days. Otherwise, it is likely to be out of service for some time before a team of mechanics can be mobilised.



***Figure 6***      ***Flywheel pump***

## ***Corrosion resistance***

In many countries (i.e. West Africa), the water is very aggressive. Under these conditions, pumps that are not fully corrosion resistant are faced with serious corrosion problems. Rising mains and rods need frequent replacement. In addition, corrosion of down-hole components releases iron into the drinking water, which results in an unacceptable water quality. Aggressive water makes it imperative to use only fully corrosion resistant pumps with plastic or SS rising mains and rods.

### ***User preference***

Users prefer pumps that have a high yield; they do not like pumps that have a small output and are hard to operate. Pumps that corrode, producing iron tainted water that tastes bad and stains food and clothing are generally not accepted. In addition, the look and feel of a pump can affect its acceptability. In some countries, socio-cultural non-acceptance of the pumping position when operating direct action pumps has proved an important factor in users' preference.

### ***Cost of pump and spares***

The price of a pump and especially its spare parts should be as low as possible. Economic conditions and the availability of alternative water sources effect that the threshold of how much the communities are prepared to pay is low.

### 3. *Choice of technology*

Although theoretically a great variety of systems can be put together with the various system components, the feasible technology options available to the community are usually limited in number. Local hydrogeological conditions, strategic decisions at national level, project execution policies and government's decisions to standardise may restrict the choice. Often communities have only one or two options to choose from. The communities have to make the ultimate choice, whereby any possible assistance has to be given to them to arrive at a well-judged decision. Whoever works with the communities during the extension phase (NGO and the district authorities), needs to explain the available options that are technically feasible and build up an understanding of the implications and characteristics of the technologies to facilitate decision making.

The effects of standardisation on one or a few technologies (familiarity, availability of spare parts, back up through trained mechanics) are discussed later. Benefits often far outweigh negative aspects. Governments, project planners and decision-makers have to be aware that their selection of technology options has to fit in with the prevailing circumstances. A familiar, established technology supported by efficient after-sales and repair services might be a better choice than an optimal technology.

Resource constraints make cost considerations an important factor in many developing countries. Low-cost technologies and approaches, which aim to serve the rural poor and deprived, and low-income urban populations can and should have priority to ensure that basic levels of services are provided to all. Rather than spending money on a small privileged society who can afford to pay the contribution towards investment cost for a higher level of service. In many cases, handpumps fitted on low yielding, small diameter boreholes not suitable for mechanised pumps may be the only affordable option. For this reason, our publication will mainly focus on low cost water lifting technologies.

Where the geological conditions permit, professionally constructed hand-dug wells or hand-drilled boreholes that remain operational in the dry season are in many instances the lowest cost option for small rural communities. However, in many areas the hydrogeological conditions may not allow digging of wells at acceptable cost, here the more expensive drilling of boreholes will be necessary. The hand-dug wells and machine-drilled boreholes can be fitted with a variety of water lifting devices, some of which are mentioned below. The matching of the water source (borehole/well) and the pumping device is often a determining factor for the success of an installation.

#### **3.1      *Groundwater sources***

For the sake of simplicity, the small rural water supply systems briefly described in this document are limited to the major technologies available. The most important options are described in the form of packages consisting of system components. For instance, a simple hand dug well fitted with a handpump would consist of two components, the dug well with a concrete lining and a shallow well handpump. A piped system is more sophisticated and may consist of the following main components: a drilled borehole of minimum 150 mm diameter, an electric submersible pump with associated switchgear, a diesel generator unit, a small power house for the diesel generator unit, an elevated storage tank and the pipe transmission and distribution system.

There are three major groundwater sources:

- a) Covered hand-dug wells with a diameter of ~1.2 metres,
- b) Hand-drilled boreholes with internal diameters of 100 mm,
- c) Machine-drilled wells with internal diameters of 100 mm, 126 mm and 150 mm. The internal diameter of the boreholes will depend upon the

well yield and the technology option chosen for the pumping.

These wells or boreholes might be fitted with:

- Rope and bucket
- Suction handpumps for very shallow installations of less than 7 metres
- Direct action handpump for shallow installations of up to 15 metres
- Deep well handpumps for installations between 10 and 45 metres
- Small submersible electric centrifugal pumps driven by electricity from the national grid
- Small submersible electric centrifugal pumps driven by a small diesel generator
- Small submersible electric centrifugal pumps driven by a photovoltaic system
- Constant cavity Mono pumps directly driven by a small diesel engine
- Piston pumps driven by a windmill

Small mechanised systems might have just a reservoir (tank) next to the well or might have an overhead tank and a small reticulation system. The outlet could be stand posts, or yard taps.

There are also other water sources, such as treated surface water, spring catchment or rainwater harvesting. If feasible, these options should be considered as well. The SKAT series of Manuals on Drinking Water Supply deals in detail with some of these technologies. In our publication we will concentrate on groundwater based options.

Each major component is depicted on a component sheet in the following pages. The purpose of this catalogue of technologies is to serve as a guide for the field staff working in villages and the users. Therefore, the text is kept to a few key messages and the illustrations are as non-technical as possible. It outlines the conditions under which a technology can be applied; its limitations; the suitability under hydrogeological conditions; typical cost for construction and O&M; and management requirements for O&M. An electronic copy of the catalogue can be downloaded as pdf file from the SKAT/HTN website; [www.skat.ch](http://www.skat.ch)

**General note:** The below quoted typical O&M costs are recurring costs and do not include depreciation and interest costs.



### 3.1.1 Hand-dug well

#### Description

Hand-dug wells are constructed with simple tools in weathered rock, overburden or sedimentary formations. The well is lined to the aquifer with concrete rings. Penetration into the water-bearing zone can be done with caisson rings. This allows further deepening of the well in case that the water table falls.

Construction can be done with a high degree of community participation. Digging and the construction work give the villagers a chance to contribute. They can work on their facility under supervision from the construction company.

Alternative designs employ different lining methods such as in-situ lining by casting concrete into moulds, cement block lining, ferro-cement lining.

#### Technical data

Well diameter (mm):	~1300
Outside diameter (mm):	~1500
Caisson Outside dia. (mm):	~1100
Caisson Inside dia. (mm):	~900
Depth range (m):	5 to 20 (max.)
Assumed Yield (m <sup>3</sup> /h):	0.5
Service Population (nos.):	150 – 200

#### Water lifting devices

- Bucket and rope
- Windlass
- Handpump (Direct Action Pump)

High yielding dug wells could be equipped with floating solar-pumps (as used for irrigation) or, if the water table allows it, above ground centrifugal pumps.

#### Features and limitations

- It provides a minimum service level.
- The well cover provides protection, but water can be polluted if rope and buckets are used.
- Fitted with a reliable and easily maintainable direct action handpump the danger of polluting the well is reduced.
- Risk of drying up during dry season or drought.

#### Design

Standard designs can be used.

#### Construction

Digging can be difficult in loose soil conditions. In hard rock conditions compressors, jackhammers and sometimes blasting are required.

Maximum feasible depth for digging is ~20 m.

#### Operation and maintenance

Maintenance requirements are minimal, cleaning the well site and occasional repair of the apron.

#### Cost

Construction costs are moderate (USD 900 to 1,500). If equipped with bucket and rope as lifting device per capita investment is as low USD 5-10/cap.

Maintenance costs are minimal (annual well and apron maintenance USD 15).

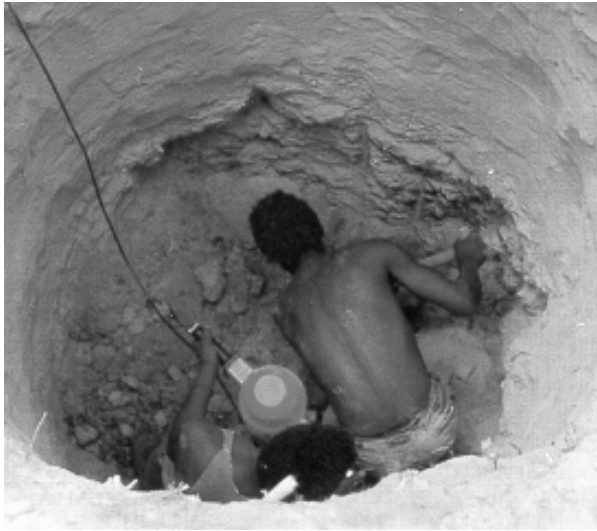

Figure 7 Well digging

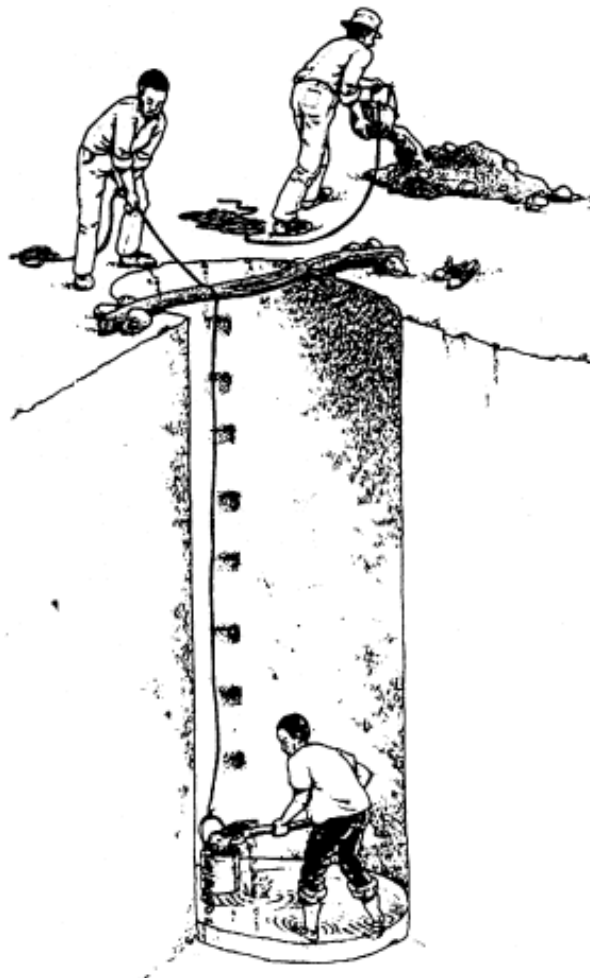

Figure 8 Digging a well

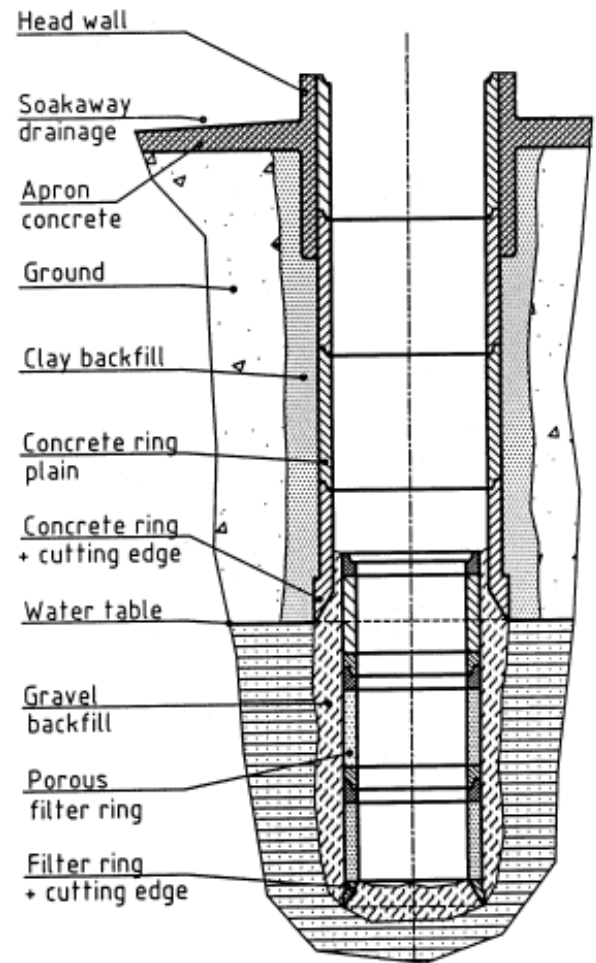

Figure 9 Ring well



Figure 10 Hand-dug well

### 3.1.2 Hand-drilled borehole

#### Description

Hand-drilled boreholes are normally constructed in sedimentary formations. If the transmissivity of the aquifer is high enough, they can provide a sufficient yield for a handpump. Hand-drilled boreholes are constructed with simple hand-operated drilling equipment. The boreholes are lined with PVC casing. A concrete apron is constructed for the handpump.

In the alluvial plains in India and Bangladesh, drilling by "sludger method" is prevalent. Such tubewells are not lined, the borehole collapses around the rising main of the pump.

As drilling operations are manual, it allows the villagers themselves to do a high percentage of the work under supervision from the drilling company.

#### Technical data

Borehole diameter (mm):	~250 – 300
Casing Pipe dia. (mm):	~250 – 300
Filter Pipe dia. (mm):	~100 – 150
Depth range (m):	5 to 25 (max)
Assumed Yield (m <sup>3</sup> /h):	0.5
Service Population (nos.):	150 – 200

#### Water lifting devices

Handpump (Direct Action Pump)

#### Features and limitations

In clay and sandy soil, drilling is relatively easy. If gravel and stones are found and in semi-cemented layers such as soft sandstone, weathered granite or laterite hand-drilling is still possible. In layers with big stones and boulders, hand-drilling is not possible. New developments of hand-operated drill rigs in Africa indicate that it might be possible to use non-mechanised drill rigs also in hard rock areas.

Boreholes provide a good protection against pollution.

#### Design

Survey drilling of a small pilot borehole is used to establish the design parameters.

Standard designs can be used.

#### Construction

A tripod is erected over the well site, and then 4 to 6 people operate the drillrig.

Maximum feasible depth for hand drilling is ~20 –25 m.

#### Operation and maintenance

Maintenance requirements are minimal, cleaning the well site and occasional repair if the apron is damaged.

#### Cost

Construction costs are moderate (USD 800 to 1,200). If equipped with a direct action pump as lifting device, per capita investment is as low as USD 12-15/cap.

Maintenance costs are (annual handpump, well and apron maintenance USD 45).



Figure 11 Hand drilling

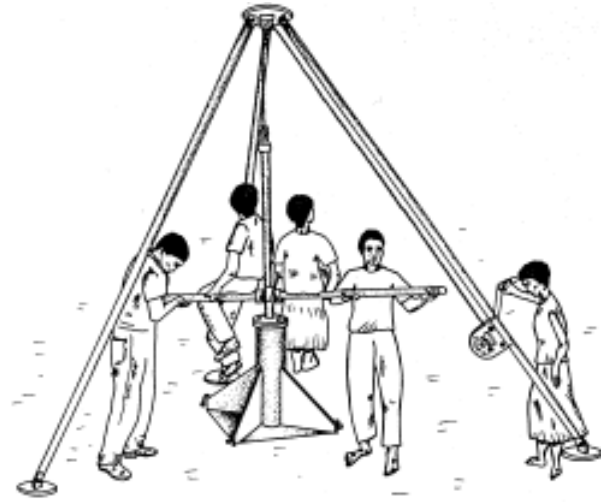

Figure 13 Well drilling

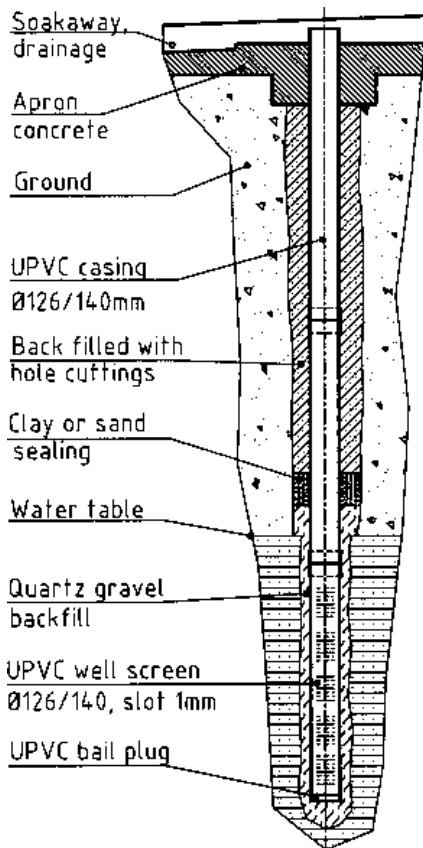

Figure 12 Borehole



Figure 14 Hand drilling with sludger method



### 3.1.3 Machine drilled borehole

#### Description

Borehole depths normally vary from about 25 to about 80 metres in basement and sedimentary formations. In exceptional cases, the depths might be as deep as 200 metres. Well siting might require geophysical surveys. Hydraulic rotary rigs or percussion rigs are normally used for drilling in sedimentary formations. Hard rock drilling requires down-the-hole hammer drilling. Slotted screens are installed at the level of the aquifer. The boreholes are normally fully lined with PVC casing pipes in sedimentary formations. In hard rock formations, the wells might be fully lined or the casing pipes only go through the overburden down to the hard rock, lower part remains unlined. A concrete apron is constructed for the handpump.

As drilling operations are mechanised, they give little opportunity for participation by the villagers.

#### Technical data

Borehole diameter (mm):	~160 – 200
Casing Pipe dia. (mm):	~100 – 200
Filter Pipe dia. (mm):	~100 – 200
Depth range (m):	25 to 200 (max)
Assumed Yield (m <sup>3</sup> /h):	1 – 20
Service Population (nos.):	300 – 2000 (depending on yield)

#### Water lifting devices

- Manually operated pumps
- Mechanised pumps

#### Features and limitations

If only a handpump yield of 1-2 m<sup>3</sup>/h is required drilling is possible almost anywhere.

Boreholes provide a year-round water supply and give a good protection against pollution.

#### Design

The geophysical survey allows to establish the design parameters.

Standard designs can be used.

Boreholes might be lined to the full depth or only in the overburden.

Artificial Gravelpacks might be applied.

Apron design should take into consideration the users needs. In desert areas, it may be necessary to construct a cattle trough.

#### Construction

Siting and Drilling requires specialised technical skills.

#### Operation and maintenance

Depending on the geological formations the borehole might require maintenance about once every ten years, when it needs to be cleaned and redeveloped.

The apron has to be kept clean and may require occasional repairs.

#### Cost

Construction costs are estimated between USD 4,000 and 15,000 in Africa depending on diameter, depths, and design. Regional cost variances are considerable between East and West Africa (West Africa being 2-4 times more costly). Even more pronounced are cost differences between Africa and Asia (in India a 80 m borehole costs USD 1,000).

Maintenance costs depend on the pumping device (annual cost for well and apron maintenance only is USD15).

Well redevelopment costs are (USD 500 to 1,200, every 10 years).



Figure 15 Drill rig

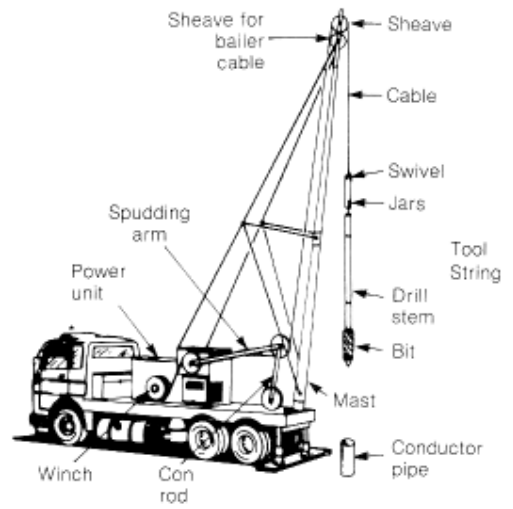

Figure 17 Percussion Rig

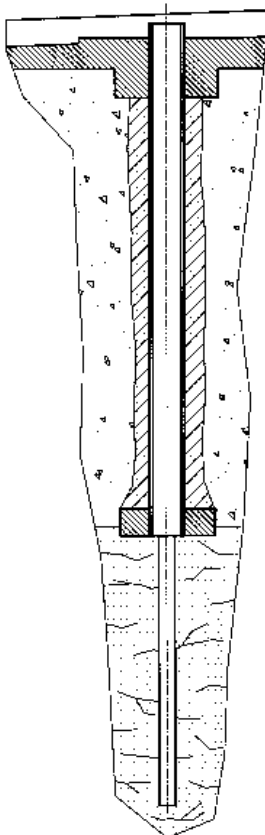

Figure 16 Borehole unlined



Figure 18 Small Rotary Drill

## 3.2 Pumping technologies

Chapter 2 deals with the theoretical issues of lifting water and some of the aspects on designs. In [Chapter 9](#), Handpump Fact Sheets, the most common handpump types are briefly described. Therefore, the technology description here is kept to a minimum.

### 3.2.1 Suction hand pumps

#### Description

Suction pumps have all moving parts above ground. The piston is operated in a cylinder in the pump body. Therefore, the operating depth is limited by atmospheric pressure to 6-8 metres.

#### Technical data

Cylinder diameter (mm):	60 – 80
Maximum Stroke (mm):	400
Approx. discharge lt./min:	30 – 60 (depending on installation and well)
Pumping lift (m):	0 – 7
Daily output (m <sup>3</sup> ):	1 – 3
Population served (nos.):	70 – 150
Households (nos.):	10 – 20
Type of well:	borehole or dugwell

#### Material

Pump head:	Cast Iron
Handle:	Cast Iron
Rising main:	PVC pipe
Plunger/footvalve:	Brass

#### Local manufacturing

The Suction pumps can easily be produced in developing countries.

#### Installation

The installation of the suction pumps is easy and does not need any lifting equipment or special tools.

#### Maintenance

These pumps have an excellent “Community Management Potential” since all wearing components are above ground. Only simple tools are needed for all repairs. These pumps are reliable and popular with the communities.

#### Remarks

Suction pumps are limited to pumping lifts of a maximum of 8 m.

They are normally family pumps for smaller user groups (50-70 users).

They require priming. If the footvalve is leaking, use of polluted water for priming the pump may pollute the borewell.



Figure 19 Suction Pump

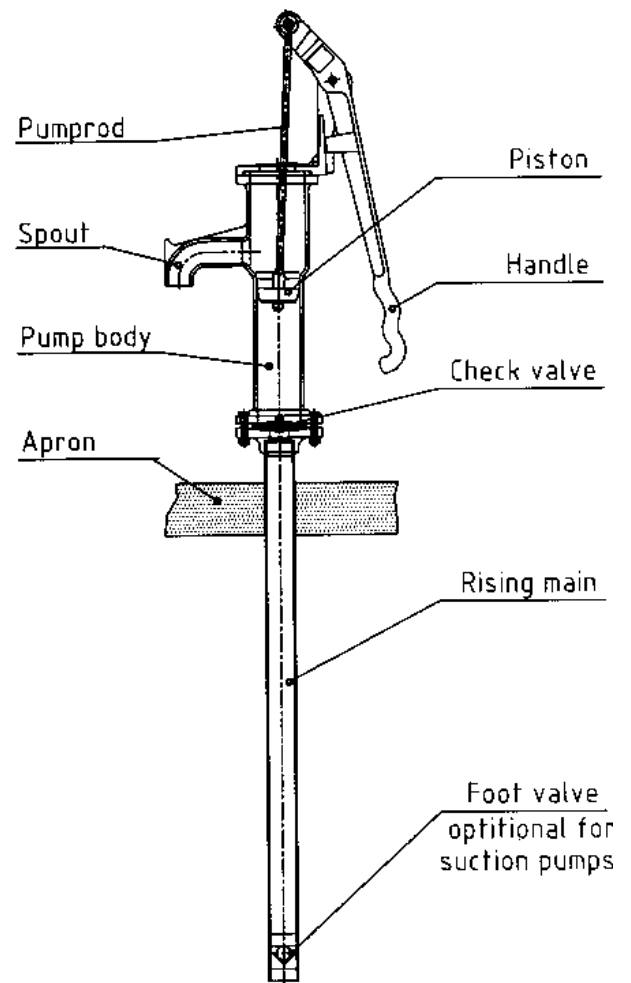

Figure 20 No. 6 Pump

### 3.2.2 Direct Action handpumps

#### Description

The Direct Action Handpumps are based on a buoyant pump rod that is directly articulated by the user, discharging water at the up- and down stroke. The pump head and the standing plate are made of galvanised steel and the handle of stainless steel. Pump rod and rising main are of HDPE or PVC pipes (with threaded connections) and the rest of the down-hole components are made of plastics. This makes these pumps completely corrosion resistant.

#### Technical data

Cylinder diameter (mm):	50 – 53.4
Maximum Stroke (mm):	~400
Approx. discharge lt./min:	30 – 60 (depending on installation and well)
Pumping lift (m):	2 – 15
Daily output (m <sup>3</sup> ):	1 – 5
Population served (nos.):	300
Households (nos.):	30
Type of well:	borehole or dugwell

#### Material

Pump head:	galvanised steel
Handle:	SS
Pump rods:	HDPE/PVC pipe
Rising main:	HDPE/PVC pipe
Plunger/footvalve:	plastic

#### Local manufacturing

The direct action pumps are specially designed to be produced in developing countries.

#### Installation

The installation of direct action pumps is easy and does not need any lifting equipment or special tools. The rising main with footvalve and pumphead as well as the pump rod with handle and plunger can be assembled on the ground. When laid next to each other the correct length can be checked. Both, the rising main and the pump rod can be easily lowered into the well.

#### Maintenance

These pumps have an excellent “Community Management Potential”. Only simple tools are needed to pull out the entire pumping element as well as the footvalve and rising main. Direct action pumps are reliable and normally popular with the communities.

#### Remarks

Direct action pumps are limited to pumping lifts of a maximum of 15 m.

It is recommended not to go deeper than 12 m.

Direct action pumps are designed as “family” pumps (50-70 users) as well as “community” pumps (up to 300 users).



Figure 21 Tara Direct Action Pump

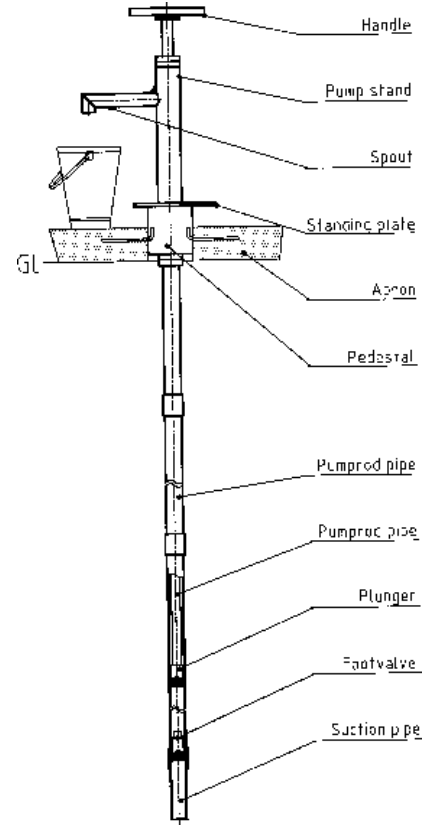

Figure 22 Drawing Direct Action Pump



Figure 23 Malda Direct Action Pump

### 3.2.3 Deep well handpumps

#### Description

Deep well pumps are normally conventional lever action handpumps. However, foot or flywheel operated designs are also used. The configuration can include an open top cylinder; i.e. the piston and the footvalve can be removed from the cylinder without dismantling the rising main. Or they can feature the conventional configuration with a small dia rising main and a bigger dia cylinder, which requires dismantling of riser main for repairs on piston and footvalve. The riser pipes are made of GI pipes, u-PVC or SS. The pump rods are of mild steel, SS or glass fibre reinforced plastic. The pumping elements, plunger/footvalve are made of brass or engineering plastics.

#### Technical data

Cylinder diameter (mm):	50 – 63.5
Maximum Stroke (mm):	125 – 250
Approx. discharge lt./min:	10 – 40 (depending on installation and well)
Pumping lift (m):	2 – 80 (100)
Daily output (m <sup>3</sup> ):	1 – 5
Population served (nos.):	300
Households (nos.):	30
Type of well:	borehole or dugwell

#### Material

Pump head:	galvanised steel
Handle:	galvanised steel
Pump rods:	galvanised/ stainless steel, FRP plastic
Rising main:	galvanised steel, stainless steel or PVC pipes
Plunger/footvalve:	Brass

#### Local manufacturing

Deep well handpumps require a good industrial base for local production. The market must be substantial enough to justify the investment in tooling. India and several African countries have achieved local production.

#### Installation

Depending on the design, the installation of deep well pumps may require specialised equipment and skilled manpower, however for newer designs the installation is not difficult and does not need any lifting equipment or special tools. Other designs require well-trained mechanics or a mobile team with lifting tackle and a comprehensive tool kit.

#### Maintenance

Many deep-well pump designs have "Community Management Potential". They are reliable, easily repaired by a village caretaker and popular with the communities. Only simple tools are needed to pull out the entire pumping element as well as the footvalve and rising main.

#### Remarks

If galvanised iron is used for rods and rising main, the pumps are not corrosion resistant and should not be used in areas with aggressive water (pH value < 6.5).

If PVC rising mains are used, the pump should not be used in unlined boreholes and very deep installations.



Figure 24 Deep Well Pump



Figure 26 Progressive Cavity Deep Well Pump

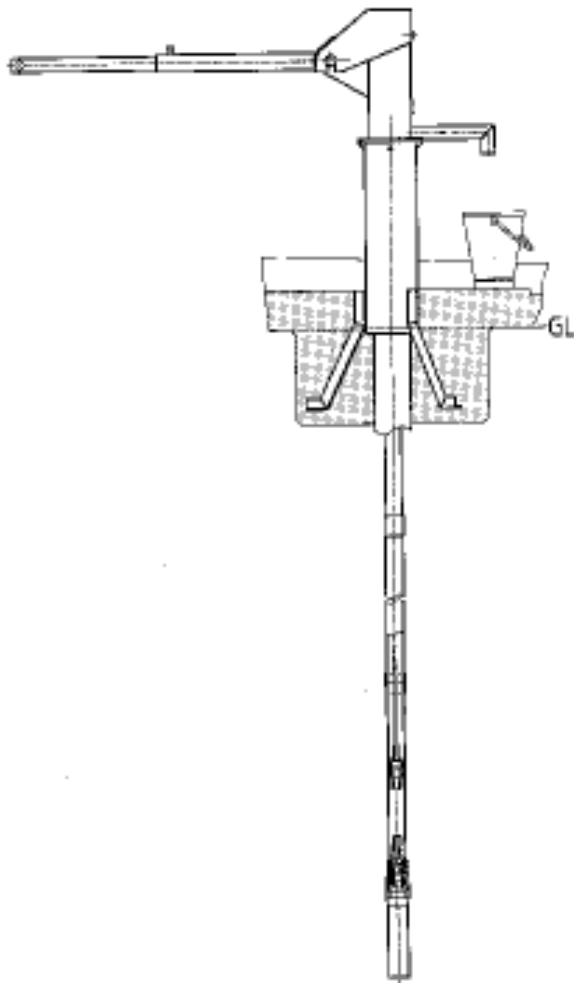

Figure 25 Deep Well Pump



Figure 27 UPM Pump



### 3.2.4 Electrically driven power pumps

#### Description

Where extensions from the national power grid reach the villages, electrically driven power pump systems are favourable for medium and large communities. This technology is well proven and does not have any limitations in pump size for the small plants needed for rural centres. The pump flow is limited by the internal diameter of the borehole. Provided it is not necessary to lay long power lines to the pump site, the capital cost for electric motor and pump are moderate. In many countries, the tariff system makes the use of electricity attractive. A water storage tank is required to ensure water supply during the period when power supplies are suspended and to balance the hourly fluctuations in demand. A distribution network with stand pipes might be installed.

#### Technical data

Pump/motor diameter (mm):	~140 – 150
Pumping head (m):	5 – 300
Discharge (m <sup>3</sup> /h):	1 – 25
Power input (kW)	1 – 20
Daily output (m <sup>3</sup> ):	10 – 100
Watertank (% of daily output):	30 – 40
Population served (nos.):	1000 – 5000
Households (nos.):	100 – 500

#### Features and limitations

A distribution network with standpipes or house connections can be installed. These provide a good service level.

#### Construction

The digging of trenches for the distribution network allows for community participation during construction.

#### Operation and maintenance

Submersible electric pumps can operate with little maintenance.

Voltage fluctuations in the grid can cause problems, or even make operation impossible.

#### Cost

The costs of these systems vary depending on the distance of the pump site from the grid, the size of the distribution network, and the type of reservoir (elevated or ground level tank). As a rule, the unit cost is in the region of USD 40,000 to 70,000.

O&M cost are approx. USD 0.80 to 1.50 per capita and year; thus comparable with a system in which the pump is driven by solar power.

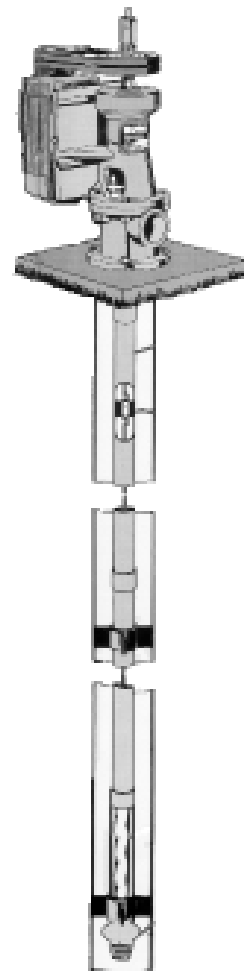

Figure 28 Electrically driven progressive cavity pump

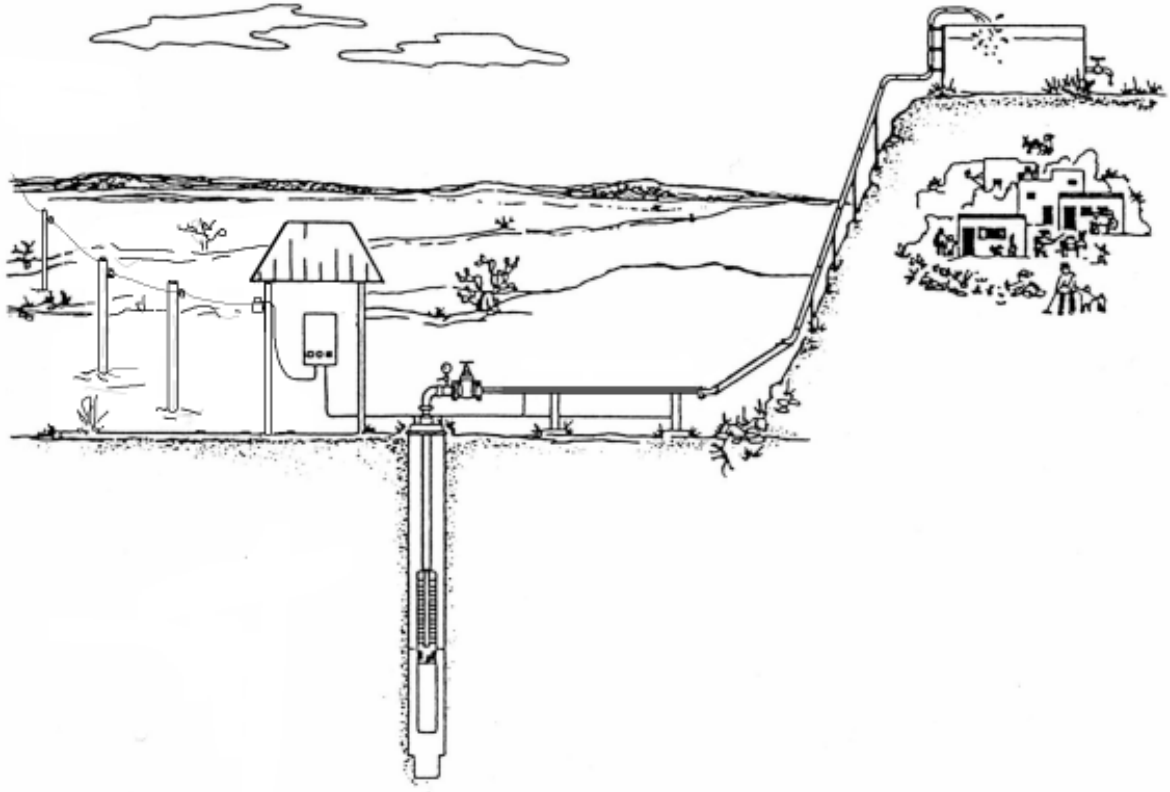

Figure 29 Power Pump System



Figure 30 Water tank



Figure 31 Stand post

### 3.2.5 Diesel driven mechanised pumps

#### Description

These units consist typically of a small diesel engine coupled with a generator that drives a submersible pump or a diesel engine driving a spindle-driven progressive cavity type (Mono-type) pump. The capital cost for engine, generator and pump are acceptable. High fuel prices and availability of diesel tend to make this option less attractive. The diesel engine requires intensive maintenance and ensured supply of spare parts. A water storage tank is required to ensure water supply during the period when the engine is not operated. A distribution network with standpipes might be installed.

#### Technical data

Pump/motor diameter (mm):	~120 – 150
Pumping head (m):	5 – 300
Discharge (m <sup>3</sup> /h):	1 – 25
Power input (kW)	1 – 20
Daily output (m <sup>3</sup> ):	10 – 100
Watertank (% of daily output):	30 – 40
Population served (nos.):	500 – 5000
Households (nos.):	50 – 500

#### Features and limitations

A distribution network with standpipes or house connections can be installed. These provide a good service level.

#### Construction

The digging of trenches for the distribution network allows for community participation during construction.

#### Operation and maintenance

Diesel driven pumps require an operator to be on attendance when in use.

They need constant maintenance and the supply of spare parts needs to be ensured.

Fuel supplies need to be organised.

#### Cost

The costs of these systems vary depending on the size of the distribution network, and the type of reservoir (elevated or ground level tank). As a rule, the unit cost is in the region of USD 40,000 to 70,000. O&M cost are approx. USD 0.50 to 2.50 per capita and per year; this is about 25% higher than for a solar system or system in which the pump is driven by electricity from the grid.



Figure 32 Diesel driven pump

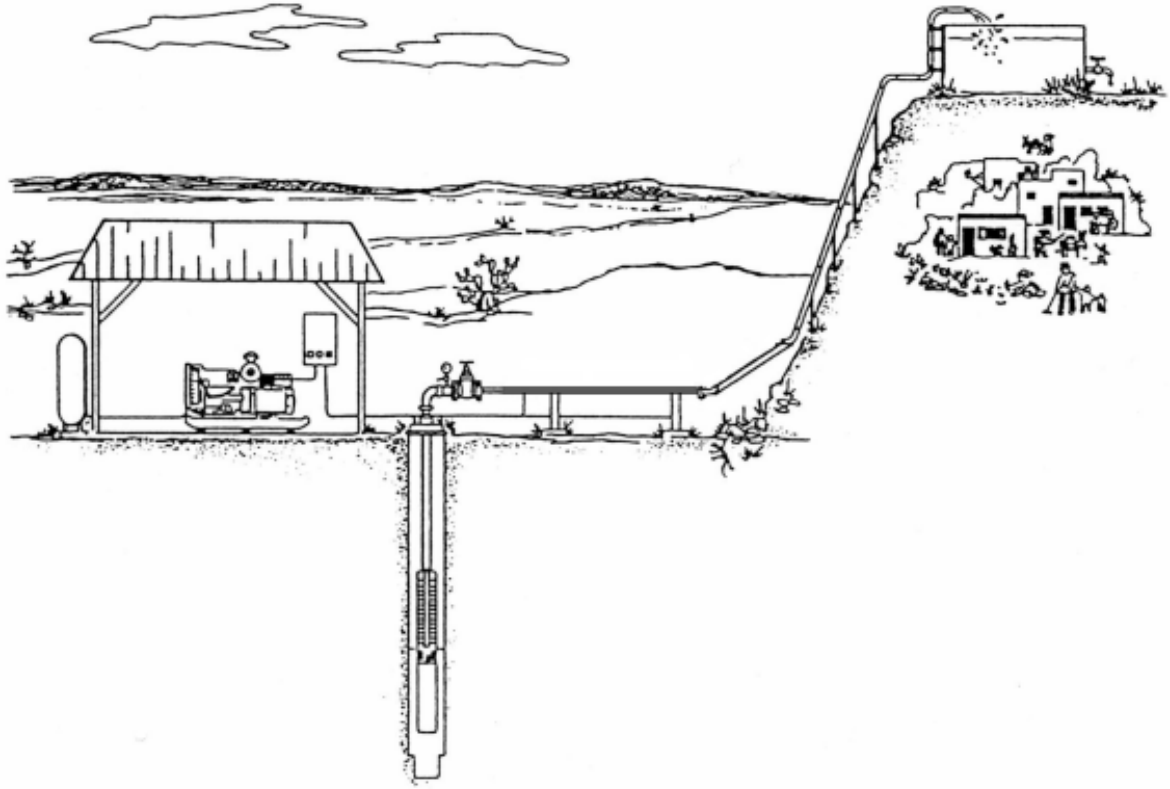

Figure 33 Diesel Pump System

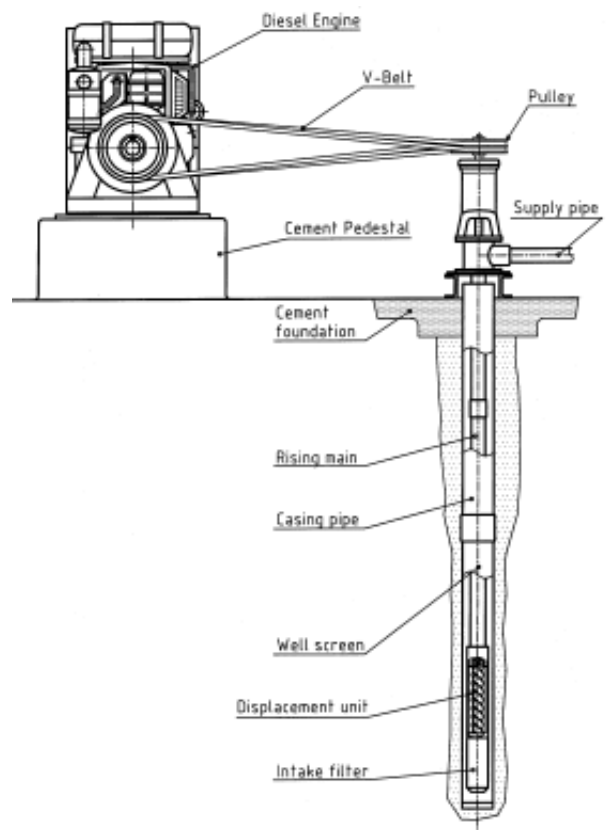

Figure 34 Diesel Pump

Figure 35 Dieselpump with progressive cavity pump

### 3.2.6 Solar powered mechanised pumps

#### Description

Presently there are two major types of solar pumps; both are photovoltaic pumping systems converting sunlight directly into a DC current. One system converts the DC current of the PV array into a conditioned AC current by means of an inverter, which drives a speed regulated three-phase submersible centrifugal pump. The other type employs a submersible pump fitted with a DC electric motor. This system does not require an inverter. The array of solar panels is mounted on a frame. The pumps operate automatically when the solar radiation supplies enough energy to run the electric motor. The system runs virtually maintenance free. Solarpumps normally fit into 126 mm dia borehole.

A water storage tank is required to ensure water supply during the time when the pump is not running and to balance the hourly fluctuation in demand. A distribution network with stand pipes might be installed.

#### Technical data

Pump/motor diameter (mm):	~100 – 150
Pumping head (m):	5 – 120
Discharge (m <sup>3</sup> /h):	1 – 15
Power input (kWh/m <sup>2</sup> /day)	4.5 – 5.5
Daily output (m <sup>3</sup> ):	10 – 50
Watertank (% of daily output):	50 – 70
Population served (nos.):	500 – 2000
Households (nos.):	50 – 300

#### Features and limitations

A distribution network with stand pipes or house connections can be installed. They provide a good service level.

Solarpump systems are rather sensitive to the power requirements. The investment cost and the O&M cost rise more or less directly with the pumping head. At high lifts of more than 35 metres, alternative options might be preferable.

#### Construction

The digging of trenches for the distribution network allows for community participation during construction.

#### Operation and maintenance

Solar powered systems can operate with little maintenance. Repairs need specialised skilled personnel. They do not need any consumables.

#### Cost

The costs of these systems vary depending on the pumping lift and the size of the distribution network, as well as the type of reservoir (elevated or ground level tank). As a rule, the unit cost is in the region of USD 35,000 to 70,000. The present high price of the solar panels increases the cost of systems that require more energy (high lift).

O&M cost are approx. USD 0.80 to 1.50 per capita and year; this is the same as a system in which the pump is driven by electricity from the grid.



Figure 36 Solar Pump

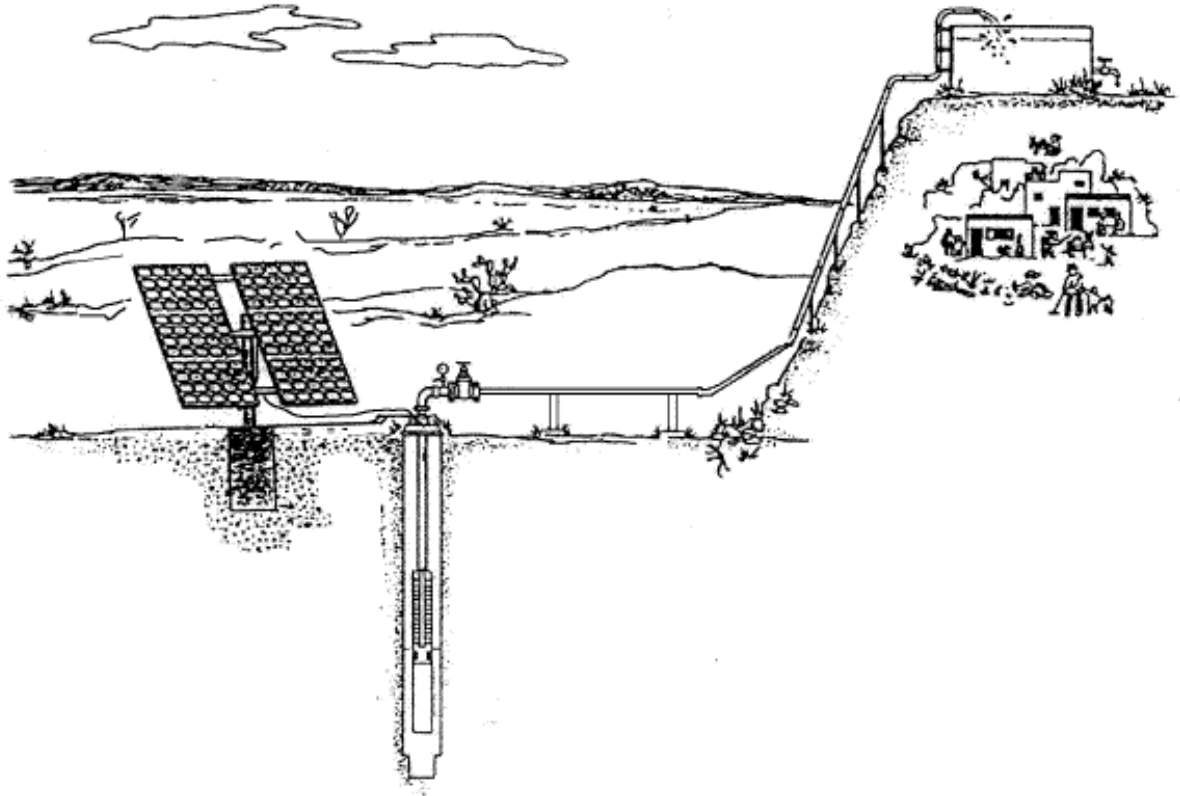

Figure 37 Solar Pump System

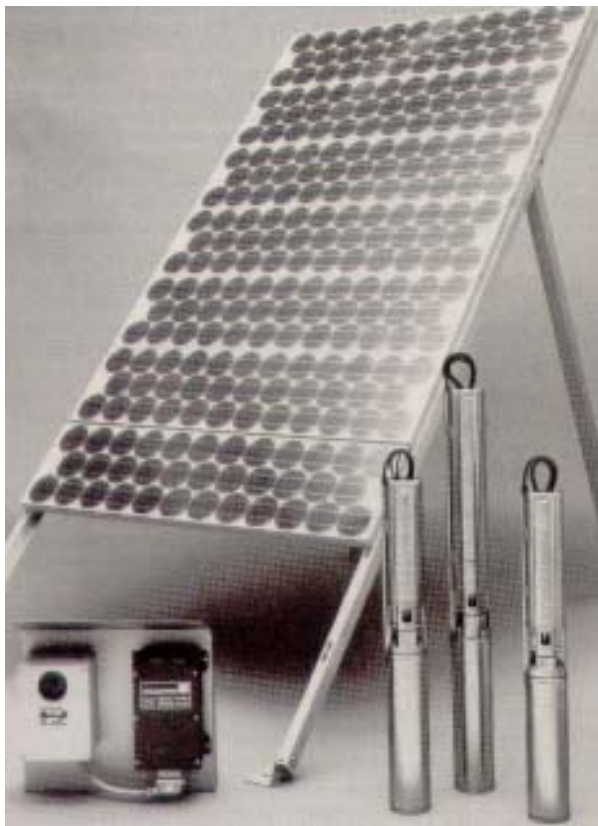

Figure 38 Solarpanels

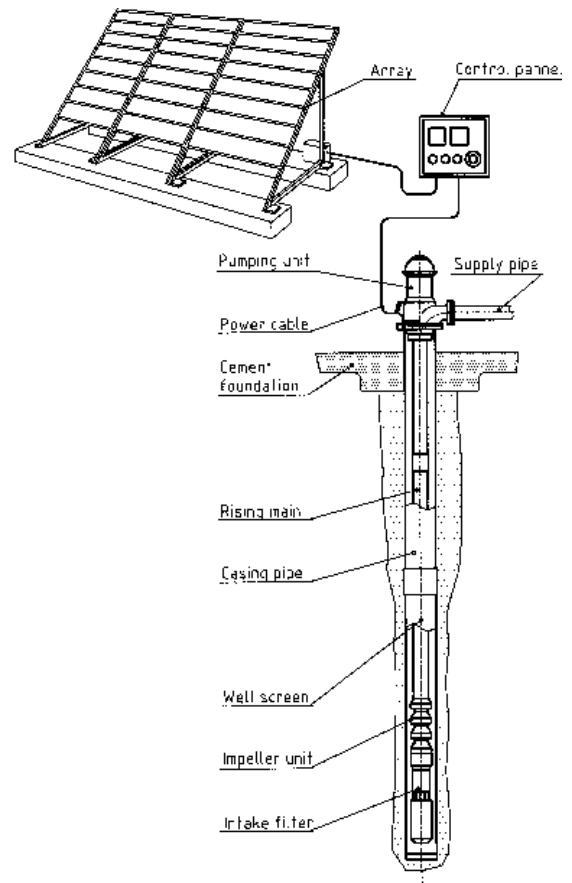

Figure 39 Solar System

### 3.2.7 Wind powered pumps

#### Description

Windpumps normally have a steel multi-bladed, fan-like rotor which drives via a reduction gear box a reciprocating pump linkage that is directly connected to a piston pump located below in the borehole. Windpumps are often applied at high heads: typically, 10 to 100 m. Inevitably, because of the robust nature of their construction, windpumps are quite expensive in relation of their power output. However, the O&M cost are moderate. Windpumps run with little maintenance for many years.

A water storage tank is required to ensure water supply during when the pump is not running and to balance the hourly fluctuation in demand. A distribution network with standpipes might be installed.

#### Technical data

Pump/motor diameter (mm):	~150 – 200
Pumping head (m):	5 – 100
Daily output (m <sup>3</sup> ):	3 – 50
Watertank (% of daily output):	100
Population served (nos.):	500 – 2000
Households (nos.):	50 – 300

#### Features and limitations

A distribution network with standpipes or house connections can be installed. These provide a good service level.

Windpump systems are only feasible where a regular wind is ensured. In order to withstand occasional storms, windmills must have a means to limit the power they can deliver.

#### Construction

The digging of trenches for the distribution network allows for community participation during construction.

#### Operation and maintenance

Windpumps can operate with little maintenance. Repairs need specialised skilled personnel. They do not need any consumables.

#### Cost

The costs of these systems vary depending on the pumping lift and the size of the distribution network, the type of reservoir (elevated or ground level tank). As a rule, the unit cost is in the region of USD 35,000 to 60,000.

O&M cost are approx. USD 0.80 to 1.50 per capita and year; this is the same as a system in which the pump is driven by electricity from the grid.

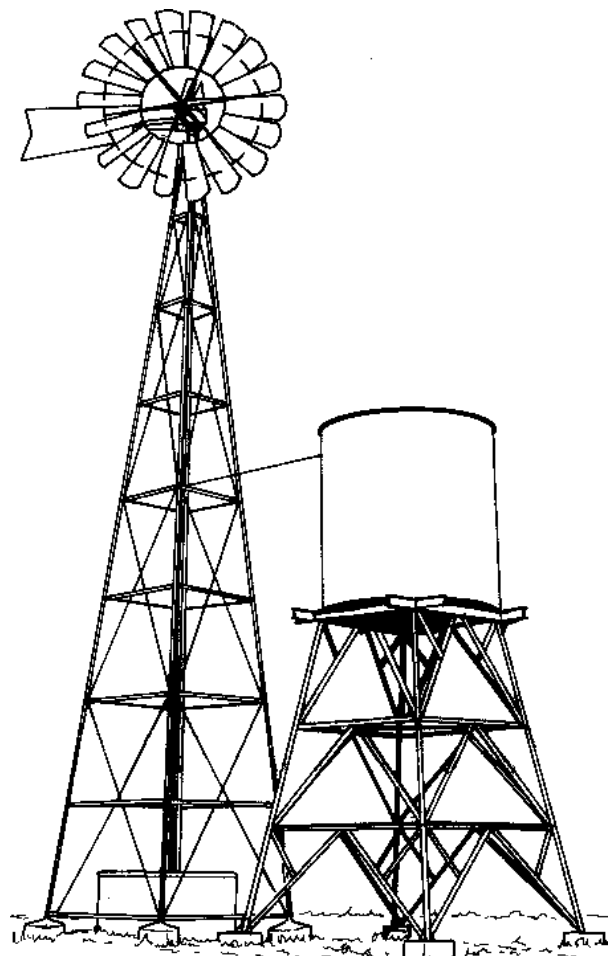

Figure 40 Windmill pump

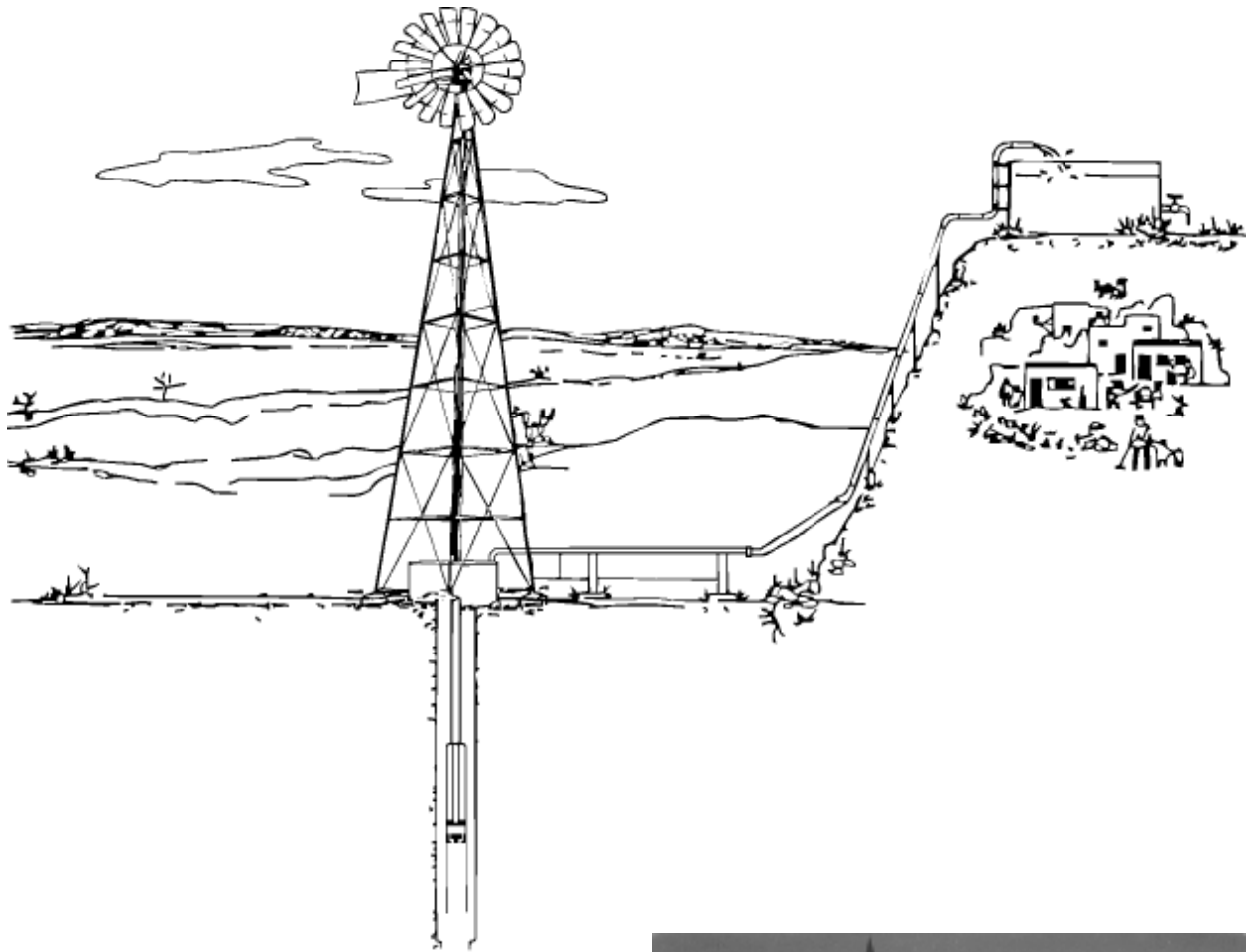

Figure 41 Windmill Pump System

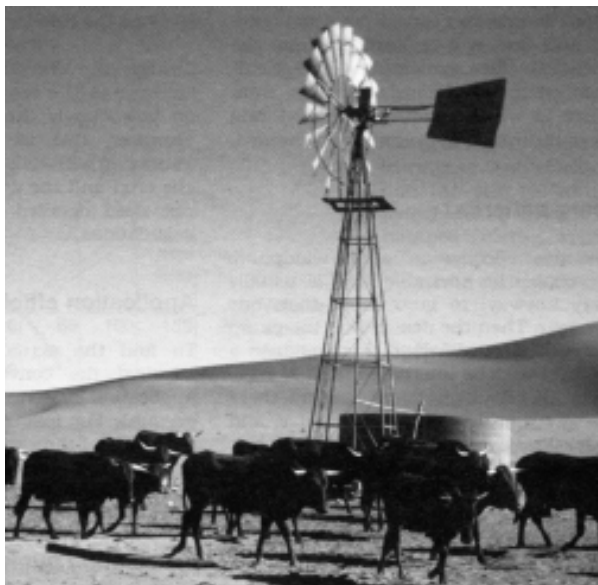

Figure 42 Windmill pump



Figure 43 Windmill pump



## 4. Typical cost for small water supply systems

The estimated cost for the technologies depicted in the previous chapter were calculated to serve as a general guideline. It should, however, be stressed that cost may change substantially from country to country and region to region. Price levels are higher in West Africa than in East Africa. Even more pronounced are cost differences between Africa and Asia (a factor of 5 to 20 applies). However, the relations remain valid.

It should, however, be mentioned that cost calculations are difficult to compare. There are no standardised guidelines for costing of typical investment costs and running costs. The results might vary considerably, depending on what factors are chosen for:

- (a) contingencies on capita investment;
- (b) overhead on capita investment;
- (c) rate of interest for capital amortisation (applicable in calculating O&M and depreciation costs); etc.

All such factors can change greatly from country to country and project to project.

The cost of the technology options can be summarised as follows:

### 4.1 Hand-dug wells, Hand-drilled boreholes,

This technology offers the lowest investment per capita (\$11/cap) and the lowest annual unit cost for communities of sizes from 50 to 5000 inhabitants. However, this technology provides only basic service and can only be used where drilling or digging is possible and the water is relatively near the surface.

### 4.2 Boreholes (high- or low-yielding, small or big diameter),

Peter Wurzel discusses the cost implications of design parameters in borehole drilling in detail in the SKAT/HTN publication: *"Simplified low cost drilling for handpumps"*.

Peter Wurzel made some essential points in his book, which are briefly summarised in the following table.

<i>Higher yields require:</i>	<i>Consequence:</i>
Deeper boreholes	Bigger rigs needed, cost per metre goes up
Bigger diameter boreholes	Bigger rigs needed, cost goes up
Elaborate site investigations (geophysics)	Cost for siting goes up, risk of failures is higher
Intensive well development	Gravelpack needed, screens with high open area needed cost for pumptesting goes up

Table 1

The sufficient well yield for a handpump is about 1 m<sup>3</sup>/h. This allows a simplified specification for the borehole, which can reduce cost considerably. This type of simplified borehole can however not be fitted with a mechanised pumping system and it can only serve up to 500 persons. Drilling for yields of 5-10 m<sup>3</sup>/h requires a more sophisticated drilling and siting technology and a mechanised pump needs to be fitted. Such a borehole might be able to serve 1,000 to 2,000 or more people.

P. Wurzel argues that if a mismatch is specified between the pumping device and the borehole, i.e. a handpump on a over-specified borehole, the cost of the water source can easily be twice as high than necessary. Considering that Africa alone needs as many as 100,000 boreholes in the next years, a saving of USD 3,000 per water point could make a big difference, especially under the present funding constraint. Therefore, the "careful selection of the optimal specification for the borehole" can have a big impact. It is unlikely that a community, which has the means to pay for higher O&M costs, would opt for a handpump when it is given the opportunity to acquire a motorised system. However, if the principles of "willingness to pay" and "first come, first served" are used only in DRA it might effect that the poorer segment of the population is left out. The challenge in the next 2 or 3 decades will be to offer the rural population a realistic mix of technologies that are cost effective and at the same time fulfils the demands of the users.

As a rule, for smaller communities with 50-1,000 inhabitants point sources with handpumps are the most economical choice and should be preferred. Whereas for larger habitats with the population exceeding 1,000 citizen, mechanised systems with either stand posts or yard taps might become feasible.

Where reliable power is supplied from a grid, and the community has a population of about 2,500, the investment per capita and the cost per m<sup>3</sup> of water for a submersible pump powered by the grid would be basically in the same range as the cost for boreholes equipped with handpumps. For larger communities, the cost will decrease. Long distances from grid to pump site and the village to the pump site, in conjunction with a low population density can double these costs. Under such unfavourable conditions, handpumps would even be

more cost effective for larger communities. Respectively, the better choice could be a diesel generator or a solarpump system. Contrary to solar systems, higher pumping heads do not push up the operation costs of a diesel driven system disproportionately as the additional energy cost is reasonable. Such a system would, therefore, have its advantages when high lifts are encountered.

For a community with 1,200 inhabitants, the investment cost of a mechanised pump powered by a diesel generating unit would be almost identical with the cost of a system with electricity supply from a grid, the extra cost for the diesel generator being greatly offset by the cost of the power line. However, the annual running cost would be about 20%-25% higher for the system with the diesel generator. The electricity from the grid normally costs far less than the fuel for the diesel generator. Naturally a diesel generator requires increased servicing and maintenance and may require a full-time operator. Diesel generator systems have the advantage that they are independent from a grid, which may be some distance away from the well site, and may provide low voltage or intermittent electricity.

For communities with 600 inhabitants, small solarpump systems powered by photovoltaic panels may be cost-effective when pumping directly into small ground level reservoir. Solarpumps have a high potential for communities between about 1,000 and 2,000 inhabitants, especially when the pumping head is low. At present the standardised small solar systems with up to about 1,600 Wp panel size are of interest, because of their acceptable cost and proven reliability. Photovoltaic solar panels are still quite expensive, which results in high capital costs. In addition, the standardised systems are still rather small in capacity so that larger communities would need more than one solarpump with extra wells/boreholes.

Solarpump systems are rather sensitive to the power requirements for high pumping heads. At a daily irradiation of 4.5-5.0 kwh/m<sup>2</sup>/day, the output of a 1,600 Wp plant when pumping against a head of 35 metres would be about 25 m<sup>3</sup>/day, supplying 1,200 people. And when pumping against 20 metres total head about 45 m<sup>3</sup>/day can be expected, supplying 2,000 people. The lower pumping head would decrease the investment cost nearly

to 50%. For communities with 1,200 inhabitants, the solarpump option can be lower in annual cost than the diesel generator and the handpump system; it would even be competitive with grid systems.

It should be noted that these are general conclusions, which would need to be verified under the local conditions. In India (where electrical power is available in the villages), solar pumps are the most expensive, and electric pumps the most economical options for communities with 1,000 inhabitants or more. The large capital cost of a solar system is a deterrent for its application.

### **4.3 Computer supported cost calculation programme**

When pricing the system components and analysing the costs, one arrives at a typical range of cost per capita or cost per unit water for standard assumptions. An exact analysis can only then be made, when the actual data from a site is drawn together. The total number of parameters is quite substantial, more so for small reticulated (piped) plants than for handpumps. Therefore, the least cost option may differ from community to community.

Some of the major parameters are mentioned below:

- (a) Drilling cost per metre and depth of borehole;
- (b) Settlement pattern of the community;
- (c) Location of the well site;
- (d) Well yield;
- (e) Pumping lift;
- (f) Cost of labour, fuel and electricity;
- (g) Cost of major machinery, especially solar panels, etc.

To help in finding a decision whether a small piped system or a handpump based system is more cost effective, HTN prepared an Excel based spreadsheet programme, which calculates for all available technology options:

- Total Investment Cost;
- Investment Cost per Capita;
- Overall O&M Cost per Annum;
- Yearly O&M Cost per Person;
- Unit Cost per m<sup>3</sup> Water;
- Depreciation Cost.

The cost calculation tool allows entering the key parameters of any specific village. The data need to be compiled during a participatory assessment of the village. Results specific for the location are immediately calculated and can be shown to the community. Thus, the community has a good indication of the cost implications ahead of it to make an informed decision on technology choice. The use of a computer programme based on actual village parameters produces cost indicators that are much nearer to reality than the typical cost calculated based on general assumptions.

This programme is available for downloading on the HTN/SKAT Website; [www.skat.ch](http://www.skat.ch)

<b>Community parameters</b>		
Water consumption	25	lt/cap
Demographic characteristics		
Total no. of households	150	Nos
Persons per household	6	Nos
Total population	900	Nos
Households per hectare		
Population density core area	120	Nos/ha
Population density total area	12	Nos/ha
Percentage core area	0.33	%
Total area	19	ha
<b>Production and distance parameters</b>		
Production of new source (m <sup>3</sup> /day)	22.5	m <sup>3</sup>
Distance to source	500	m
Distance source to tank	100	m
Distance tank to core area	400	m
Spring elevation over village	75	m
Distance form grid power supply	80	m
<b>Water table and pumping parameters</b>		
Static water table	12	m
Total pumping head	22	m
Elevation source to tank	10	m
<b>Economic conditions</b>		
Avg. value of time (USD/hr)		
Avg. value of water (USD/m <sup>3</sup> )		
Interest rate	0.1	%
Electric power cost (USD/kwh)	0.15	USD/kwh
Diesel fuel cost (USD/litre)	0.8	USD/litre
General overheads and contingencies	0.25	

**Total Investment Cost in USD**

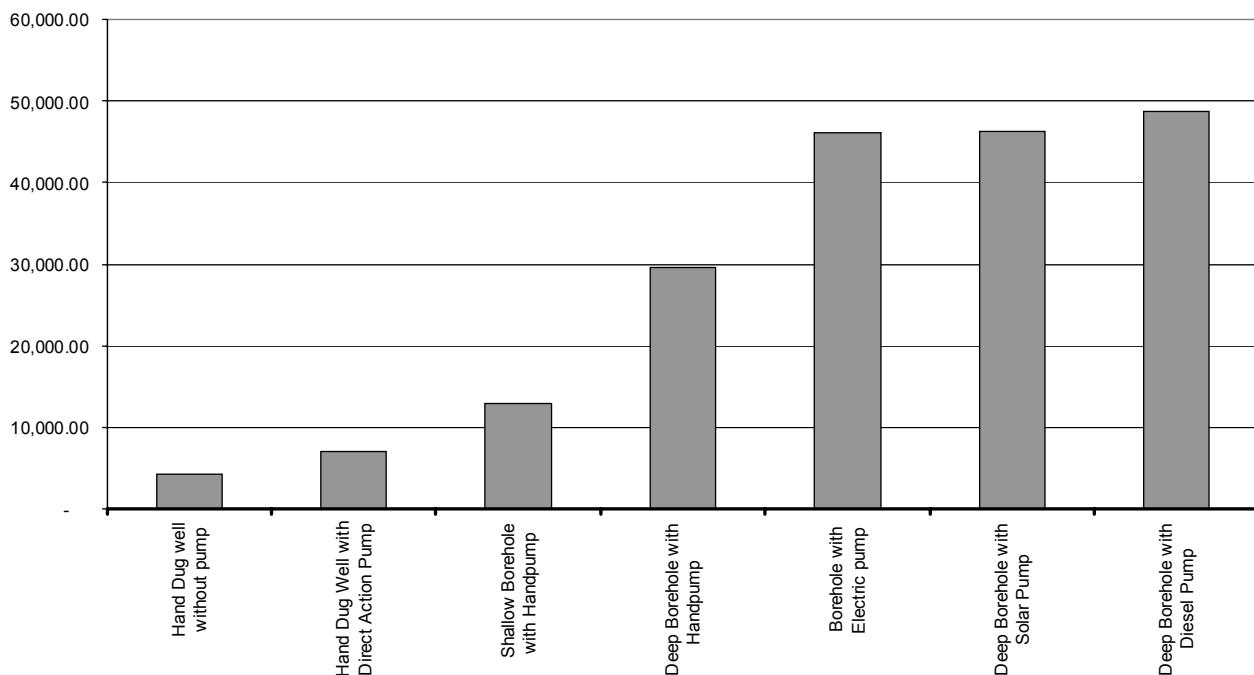

Figure 44 Investment cost

### Investment Cost per Capita in USD

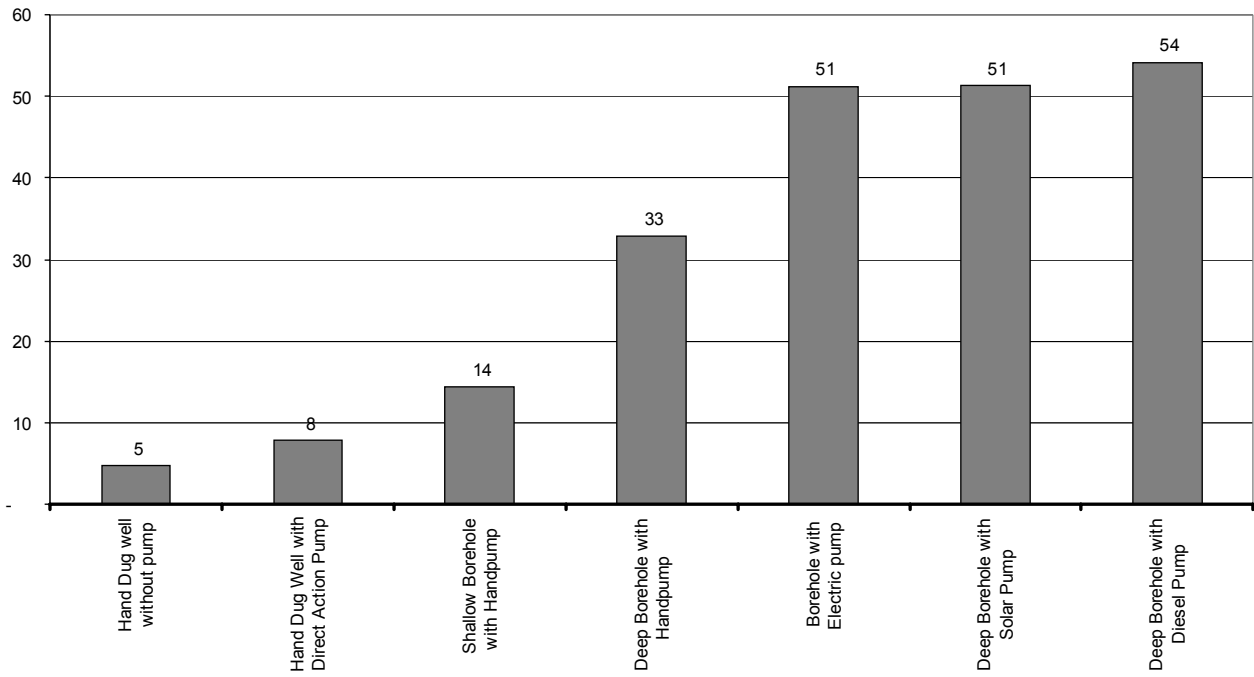

Figure 45 Investment cost per capita

### Maintenance Cost per Capita in USD

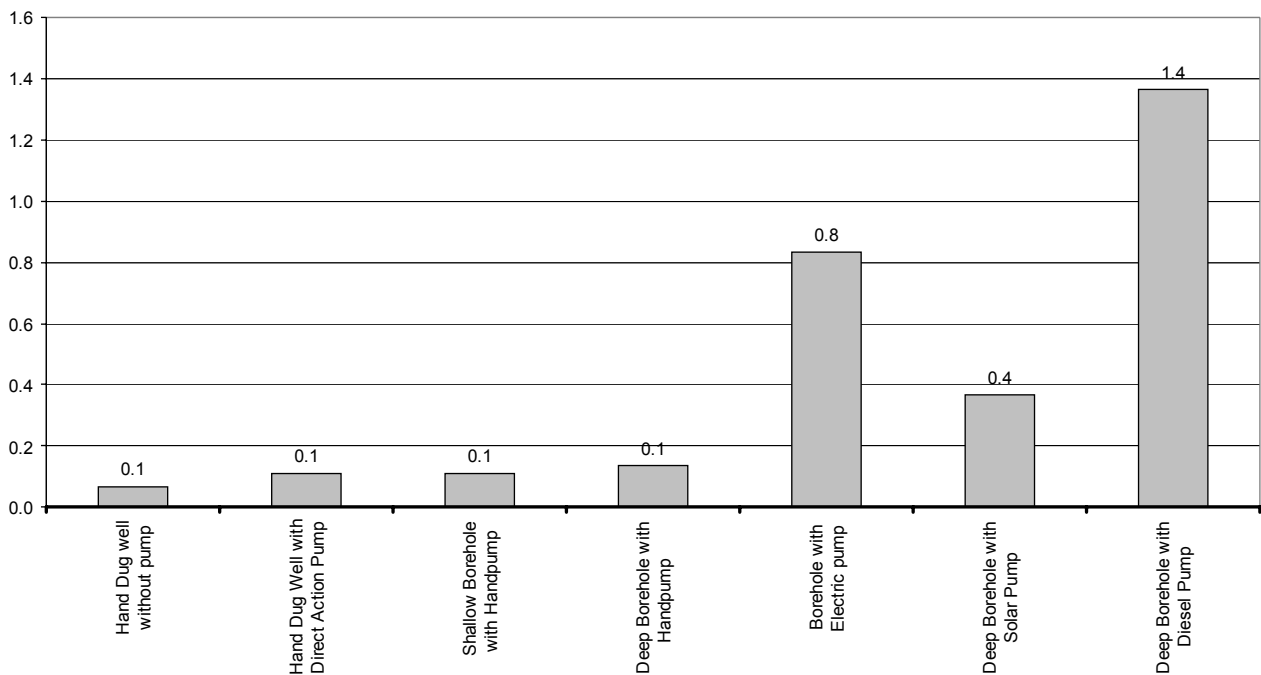

Figure 46 O&M cost per capita



## 5. *Institutional framework*

### 5.1 *Role of stakeholders*

The present trend calls for adoption of the DRA in the implementation of national rural water policies. DRA includes a decentralised, district based approach in which the rural communities have to share the cost and to take the responsibility for the management of their water points and sanitation facilities. The willingness of the rural communities to participate in the planning, the construction and the maintenance of their facilities is crucial for the success of such an approach. Village communities can only assume this responsibility if they have partners at community/district level with which they can collaborate in this task. The key actors in this joint task are the district water authorities, sometimes appointed partner organisation (NGOs) and, the private sector entrepreneur.

The implementation of decentralised, district based RWSS programmes could involve the following agencies and activities.

#### 5.1.1 *National level*

The role of the national government sector agency (Ministry of Water) mandated to take charge of the provision of water has changed. It has shifted from the "provider" of water supply and sanitation facilities to the "promoter, facilitator and co-ordinator" in the construction of these facilities. Also in this new function, the national sector agency continues to be the main governing body in the sector. However, it shares its assignments with the communities, the district authorities and the private sector. The national sector agency carries out many functions:

- (a) Policy and national planning functions (decisions on level of services, strategic orientation),
- (b) Seeking, co-ordinating and administrating internal and external funding of projects, co-ordination with ESA's,
- (c) Co-ordinating, guiding and supervising projects and NGO activities,
- (d) Keeping records and inventory country (country

- wide database of facilities, hydro-geological profiles), inter-linking with regional databases,
- (e) Formulation of standards and guidelines (preparation of specifications, manuals, bidding documents, contract documents, quality control procedures),
  - (f) Pre-qualification of suppliers,
  - (g) Establishing training programmes for district personnel, extension workers, construction workers and pump mechanics, etc.,
  - (h) Co-ordinating of health and hygiene education with MOH and DCD,
  - (i) Formulating guidelines for monitoring and evaluation of the programme.

The national sector agency needs to be adequately staffed to perform the work. In case of absence of sufficient staff, the agency may consider involvement of the private sector to assist in some functions, such as formulation of standards, guidelines and establishing of training programmes.

The sector agency might also provide consultancy services (or employ and supervise private companies undertaking the consultancy services) such as:

- (a) Provision of hydro-geological services,
- (b) Design of complex systems,
- (c) Provision of technical back up services (well maintenance, repair of water systems).

#### 5.1.2 *Rural water authorities at district level*

Functional district level authorities that have the ability to perform all tasks on hand are a prerequisite to the success of DRA. District water and sanitation authorities are quite complex units. They combine inputs from the district political (elected) body, the district planning office, the district water, the health and the community development authorities. These units are responsible for planning, supervising and co-ordinating all RWSS activities in the district. In view of the overall objective to improve health and the living conditions of rural

populations, the district units should not be restricted to water supply but must include sanitation and hygiene as equally important complementary aspects. The promotion and construction of latrines are of similar importance to the construction of wells and boreholes.

It takes a long time and much effort to establish such units as competent and useful bodies. Special emphasis has to be placed on capacity building and strengthening of the district institutions (planning offices, social services committees, and tender boards).

The specific functions of a district unit are:

- a) Preparation of a development plan for the provision of water points,
- b) Co-ordination and planning of all RWSS projects including NGO's activities,
- c) Financial administration,
- d) Collection of data on water resources and existing water points and to provide a feedback into the district/regional database,
- e) To inform the communities how a subsidised facility can be obtained,
- f) To form links between communities and the private sector,
- g) To assist the communities in the choice of technology and in the choice of location of the facilities,
- h) To vet, rank and forward for approval applications for subsidies,
- i) To conduct feasibility studies to plan technically sound water facilities,
- j) To review and approve designs,
- k) To prepare and issue tender documents, and standard contracts,
- l) To participate in the pre-qualification of suppliers/contractors,
- m) Administration of contracts,
- n) To supervise construction works and ensure quality standards,
- o) To inspect and certify construction works,
- p) To organise and/or conduct training of extension workers, construction workers, pump mechanics, and the various members of the village water and sanitation committees,
- q) To organise and/or conduct seminars/workshops for community management training,
- r) To keep records and inventory of all RWSS schemes,
- s) To monitor village level O&M activities.

Interventions in rural water supply service delivery have been ongoing with varied approaches in virtually all districts before decentralisation. Traditional external support agencies, supporting the sector in the districts should be encouraged to continue their support under the DRA policy.

The district units should co-ordinate ongoing activities and make the best use of already existing capacities.

The appointment of a private partner organisation/consulting firm, which is conversant with the management requirement of such co-ordination and the technical aspects of rural water supply could prove beneficial. The partner organisation may be used to undertake the promotion of RWSS policy in close co-operation with the district authorities. Existing private sector capacity in the districts can assist in planning, design, formulation of standards and guidelines, supervision, training, and implementation of schemes.

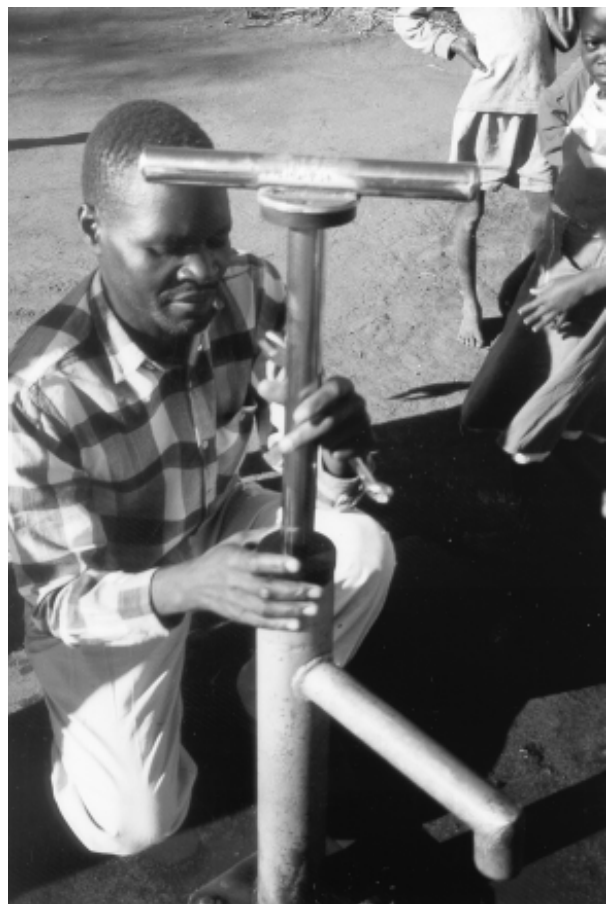

Figure 47 Handpump Maintenance



### 5.1.3 *Role of communities*

The communities need to be fully involved in all aspects of planning and should take part specifically in the following functions:

- (a) Choice of technology, design, choice of location,
- (b) Construction, labour input, contribution of building materials,
- (c) Contract(s) with the private sector suppliers,
- (d) Financing, contributions towards construction cost; O&M, management of funds,
- (e) General maintenance, operational know-how and awareness of the importance of keeping facilities clean,
- (f) Purchase of spare parts, responsibility for the use of funds.

### 5.1.4 *Role of ESA projects*

The ESA projects should take on the role of a "banker" rather than the role of an "executioner" of projects. ESAs participate with the national level sector agency in planning. They ensure through their technical staff (consultants) that the assisted projects are feasible, and executed according to national water policy.

The demand for training at all levels is usually very high. ESA can help to finance training programmes and to support the setting-up of national training institutions, which will provide training for water department-, district- and private sector staff.

## 5.2 *Extension services*

The work with communities was traditionally done by community development- and health departments. District and national level authorities may appoint NGOs and private firms to take over such social service delivery. Their function is to:

- (a) Mobilise communities to construct RWSS facilities. Educate communities on hygiene and sanitation aspects and use of safe water and latrine facilities,
- (b) Assist communities in establishing village water and sanitation committees.

The work of such agencies with the villages will ensure that the communities are aware of the benefits of a sustainable, reliable and safe water supply with improved sanitation facilities. This work

also enables the villagers to understand the water related aspects of health education. It will create a demand to acquire RWSS facilities. The villages also need to be informed of the procedures involved in obtaining improved facilities.

The extension work with the communities should help to convince the village population that the new water facilities bring a lasting improvement to their villages. Only a community, which understands the value of reliable and safe water, will involve itself actively in the planning, financing and construction and proper maintenance of the water facilities.

DRA requires the full commitment of all parties otherwise; there is the danger that sustainability is jeopardised because of a half-hearted commitment resulting in insufficient sense of ownership and subsequently bad maintenance. A set of agreed criteria need to be drawn up that determines when a community becomes ready to participate. Willingness to pay should not be the only criteria. Other aspects need to be considered, such as coherence of the decision making (is it only the village head who pushes the work or is it the entire community), social aspects (does the agreement cater for a balanced social self-control between the rich and the poor), etc.



## 6. *Standardisation and private sector support*

### 6.1 *Standardisation*

Provision of goods and services through the private sector has to be achieved within a well-defined policy framework and technical regulatory system. Standardisation and clearly defined regulations are essential preconditions for the local private sector to operate successfully. Governments (possibly with the inclusion of Standards Institutions) can standardise the technologies used. Pumps and products that are already manufactured locally at a reasonable price and quality should be given preference. Detailed standard designs and technical specifications have to be established, including drawings, bills of quantities, production procedures and quality control requirements. Wherever possible and feasible, pumps covered by an international specification (HTN, BIS) should be considered. Standardisation on public domain products will prevent distortion of the market as the prices can be checked on an international level. These international standards and technical packages define each one of the technology options in unequivocal manner and can be adapted as national standards, thus eliminating the need to devise country specific standards. They form the basis for any local or international competitive bidding.

Most countries with successful standardisation programmes received the endorsement on ministerial level or of national parliament. This high level approval is essential to implement the decision at administration and water department level. Institutional strengthening of government technical departments (Standards Sections) has to include an element of building up the capacity to prepare, disseminate, maintain and administer the national technical specifications. A technical department needs to be created within the government sector agency. It should have the necessary personnel to maintain and administer the standards and specifications and to supervise compliance with these specifications.

Private sector participation in the formulation of standards and specifications should be encouraged through the formation of associations of drilling companies, equipment- and handpump suppliers and/or construction companies. Governments should engage in a dialogue with them for the elaboration, and the periodic review and revision of the standards.

The standardisation policy gives the private sector a clearly stated indication of the technical requirements. This encourages them to invest in equipment and product specific tooling and to purchase materials in bulk. The standardisation on a few technologies also reduces the training requirements significantly both in the private and the public sector.

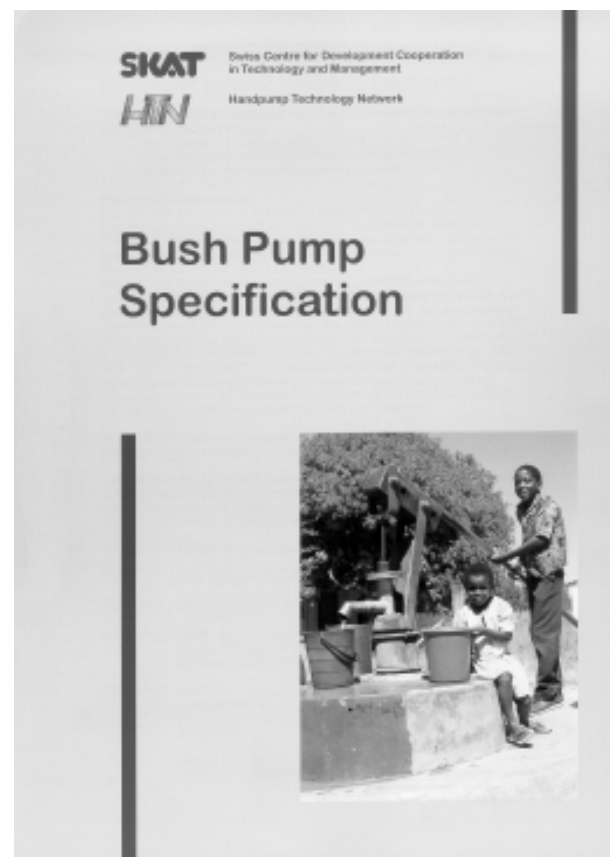

Figure 48 *Handpump Specification*

## 6.2 Pre-qualification of suppliers

Once the technologies are defined, the next step is to identify suppliers and/or manufacturers capable of making the product or providing a service as specified.

A system of pre-qualification should be introduced, under which the supplier is examined for his technical, managerial and financial capability. Information should be collected on:

- (a) Technical ability;
- (b) Infrastructure/equipment;
- (c) Financial capability;
- (d) Past performance.

Industries that do not have a system of internal quality control should be excluded. External inspection agencies may be used for verifying through a "works inspection" whether the above criteria are satisfied. Once the inspection agency gives a positive recommendation, a "trial order" can be placed on the prospective supplier. During the execution of the trial order, visits to site/factory can be made to ascertain that the necessary technical, managerial skills are available, and a quality control system is in place. A supplier/contractor that has passed the above procedure may be registered as a "Certified Supplier". Only suppliers that have reached this status should be eligible for participation in bidding for contracts. The performance of the contractor has to be reviewed on an annual basis. Those who do not comply with the quality standards should lose their registration as certified suppliers and license to operate on RWSS schemes. In this way, it is possible to keep a check on the private sector and maintain high level of workmanship.

For provision of other services to RWSS programmes, pre-qualification of agencies may be done based on the type of work. At national level drilling contractors could be qualified. At the regional or district level hand dug well and latrine contractors, maintenance contractors and NGOs or support organisations for community animation could be identified and pre-qualified.

RWSS projects may have to provide technical and managerial training to contractors and NGOs with the aim to establish themselves as private entrepreneurs or support organisations. It will be

necessary to develop specific structured training programmes for each target group. Training network centres could play a vital role in formulating the training materials and training methodologies.

Support to the private sector only makes sense if the market is substantial enough to allow the private companies to survive and carry on operating. An essential factor for the development of a strong private sector is the co-ordination of sector activities at national, regional and district level. MOW, ESAs and NGOs should co-ordinate their activities and policies in such a way that a sufficient market for private enterprises develops allowing them to operate in a free competitive environment. Procurement practices should change wherever possible from international competitive bidding to local competitive bidding.

## 6.3 Manufacture of handpumps

Many countries have successfully established local production of handpumps and other rural water supply and sanitation equipment. These efforts reduce dependence on imports and improve sustainability. However, the investments required for equipment and tooling to set up manufacturing capacity are quite high and the working capital demand is considerable. Companies starting production of handpumps need to have the necessary financial backing and the managerial ability for sustained operation. Local entrepreneurs would consider the investment for tooling only if the firm prospect of a future market exist. The minimum annual production should be at a level of 500 or more pumps.



Figure 49 Handpump Production

In Africa, most countries could realistically not support more than one or two manufacturers. Where local companies are already producing handpumps, care should be taken to ensure that this national asset is not lost. As mentioned above, a policy of standardisation helps to maintain a dependable market and thus the viability of these local private enterprises.

Local industrial capacity building can be achieved through demand-based technical assistance to the private sector in the form of technology transfer and South-South co-operation. HTN provides a pivoting point for such services.

However, in order to reach the users, greater emphasis should be placed on strengthened dealership networks and on effective service delivery mechanisms rather than on local production. Development of accomplished sales and service networks can be best assisted by promoting market oriented policies and procurement procedures, which include the local private sector, in the supply of handpumps, as well as a whole range of related services, such as drilling, installation, after-sales service, spare parts supply, and training.

### 6.3.1 Cost of local production

Cost of local production vs. imported pumps is a frequently discussed topic. Local costs are often

much higher. In Mozambique the difference between imports and local Afridev pumps were assessed. Important factors that led to the higher costs were:

- (a) Cost comparisons were often made based on one-sided assumptions. It is not correct to compare cost figures of a handpump FOB Bombay with the cost of a pump delivered to the provincial capital.
- (b) Manufacturers had to pay import duty on raw material and a sales tax on the final product. Such levies were waved for imported handpumps.
- (c) The importation procedures were relatively complicated and lengthy which effected that raw material needed to be purchased well in advance. Thus, working capital was tied up for a long time.
- (d) The cost of labour was considerably higher in Mozambique than for instance in India.
- (e) Foreign handpump manufacturers may profit from an export promotion scheme.

Many of these points could not be changed. However, at least comparisons should be fair.

To establish the sales price at a regional dealer's outlet, the following table tries to quantify the cost components of a handpump delivered to a provincial town:

Cost of Afridev Pump in USD		Imported 50 Nos. per annum	Imported 500 Nos. per annum	Locally made
1.	Sales Price FOB or ex factory	385.-	385.-	868.-
2.	Sea-freight & Insurance	60.-	45.-	
3.	Clearing and Forwarding	60.-	30.-	
4.	Customs Duty		0.-	
5.	Storage Cost	25.-	25.-	
6.	Re-packing and Local Assembly	45.-	45.-	
7.	Transportation to Provincial Centre	40.-	40.-	
8.	Supervision and Planning	60.-	40.-	25.-
9.	Capital Cost / Pre-financing	115.-	97.-	45.-
<b>Total pump delivered to Provincial Town</b>		<b>790.-</b>	<b>707.-</b>	<b>938.-</b>

*The calculations are based on the following assumptions:*

- (a) 12-18 months from order to delivery when imported,*
  - (b) typical African distances between national and provincial centres,*
- Items 2 to 9 are often not accounted for in donor assisted projects.*

Table 2

The calculation indicates that the cost of an Afridev pump made in Mozambique is higher than an imported pump. It should however be noted that the difference is less for smaller purchase orders. Therefore, small NGO's and self-help groups profit most from local production. The additional benefits from local production are the technical back-up that the producer can provide. Additional advantages include the accountability for the quality of the product, the industrial development of the country and most important the support to the spare parts supply given by a producer who is in the country. Bearing these factors in mind, it seems justified to purchase the pumps locally. If further steps are taken to involve the local producer in the training and after sales services the cost benefits ratio might even turn in favour of local purchase.

## **6.4 Procurement channels of handpumps**

Ideally, although we might be far from this vision in many places, handpumps should be purchased directly by the village communities. The cost of a handpump could be within the financial reach of the user community. Projects and policies should aim at establishing a system of cost sharing for low cost technologies in which:

- (a) The project subsidy pays for the establishment of the water point (planning, construction/drilling, supervision, etc.),
- (b) The community purchases directly the hand-pump and pays fully for it.

In order to achieve the goal of direct purchase, the community needs to have a supplier/dealer nearby. Most countries have not yet established such a regional/district dealer network, and it will take some time to create it. What is needed is a radical change in the procurement procedures. Instead of buying pumps in bulk through local or international competitive bidding, procurement guidelines for direct purchase by the communities should be established. (See also chapter 6.3 Manufacture of handpumps)

The supply contracts for handpumps (between the community and the dealer) should specify the provision of hardware (handpumps) as well as related services. The pumps could be purchased as

turnkey installations (including: supply, distribution, delivery to site, installation, training of village caretaker, provision of after-sales services). The price of a turnkey handpump installation is about twice the FOB cost, depending on the distribution system and the number of pumps involved.

A comprehensive network of regional dealers and spare part outlets in the private sector could have the following pattern:

- (a) A pre-qualified supplier imports/manufactures the pumps and spares. He appoints regional dealers, trains them in marketing and technical aspects.
- (b) The regional dealers are the licensed representatives of the supplier. They sell (at regional level) and install handpumps. They appoint area mechanics, who are trained to perform repairs, sell spare parts and assist in the installation.
- (c) The area mechanic is the link to the community. He is the representative of the regional dealer.
- (d) The village caretaker is a member of the village water committee. His interaction with the area mechanic is the backbone of the day to day maintenance of the pump.

## **6.5 Quality control**

It is expedient to establish an independent third party quality assurance for the supply of pumps. If the direct purchase of pumps by the communities becomes the rule, new ways to set up such an inspection service control need to be found. Communities will buy the handpumps only when demand arises; there will not be any bulk orders.

The national sector agency is not directly involved in the purchases; therefore, it could take on a role as an independent party. Procurement guidelines and the pre-qualification procedures should imply that only the pre-qualified suppliers are allowed to sell pumps. Supply contracts could be issued that cover an anticipated one to three year's requirements of pumps and spare parts. The national agency could for instance enter into an agreement with an inspection agency to examine the pumps ordered. Each produced/imported pump would be inspected for conformity to standard in the premises of the manufacturer or on arrival of the shipment by the independent inspection agency. If found conforming to the specifications, it is marked with an inspection certification stamp. The marked pumps could

be released individually when a community purchased a pump. The inspection contract could include the provision that the retainer for the guarantee period will be paid to the supplier after the acceptance reports from the handpump installations have been received at the end of the guarantee period.





## 7. *Operation and Maintenance*

In many countries, the national sector agencies were traditionally responsible for O&M of water systems. Thousands of handpumps were under centralised, government-managed maintenance; a huge and difficult task for understaffed and under-financed government agencies. Experience has shown that investments were often endangered because of lack of adequate maintenance.

### **7.1      *Community management of O&M***

A transition to decentralised, community managed maintenance structures is presently taking place as part of DRA. Community management has the objective of relieving the government of the day to day interventions in remote rural areas and attaining sustainability by motivating the communities to take over the full financial and managerial responsibility for O&M. The holistic approach to management of water supply means integration of all aspects (technical, financial, institutional, social, environmental and managerial) into the planning, the operation and the upkeep of water supply systems.

#### **7.1.1    *Building village level structures***

Legal ownership is an essential prerequisite for responsible management. Empowerment means, the communities take on the responsibility of decision making in relation to O&M of the water systems. Only owners can assume accountability for decisions.

As a rule, management should be delegated to lowest possible level. Ideally, water systems must be legally transferred to local bodies. Governments cannot grant ownership of infrastructures to private persons or bodies that have no legal standing. Wherever they exist, elected village authorities or registered Water User Groups can offer the necessary legal status to take over ownership. Such

bodies can decide to whom they want to delegate the responsibility of O&M. Options are: direct management; elected or appointed village water committees or user groups; subcontracts to a private enterprise or an NGO.

World-wide, DRA is considered essential when community empowerment for the management of O&M is promoted. It is believed that for community based O&M the following conditions have to be met. The communities need to:

- (a) Have contributed to the investment cost for new facilities,
- (b) Have installed the handpump themselves or have actively been involved in all stages of the planning, implementation/development of the facilities,
- (c) Have been trained to do simple repairs,
- (d) Know that the government will not maintain the assets,
- (e) Have sufficient funds for maintenance,
- (f) Be willing to pay fully for O&M.

#### ***New water supply facilities***

Normally DRA is practised in development projects where new infrastructures are planned/constructed. DRA starts from the outset for the construction of new systems, communities are motivated to participate, they have the choice of technology. With their active managerial and financial contribution, they in turn receive an improved service.

#### ***Existing water supply facilities***

In the case of existing facilities, where a transition from centralised to decentralised O&M takes place, demand and choice of technology can not play a major role (as the infrastructure is already built). Management of the existing assets will be the main challenge. However, improvement and expansion of water and sanitation services will have to go hand in hand with the upkeep of the existing infrastructures to ensure users' interest in taking

over the responsibility willingly. It will be prudent to carry out major repairs before existing facilities are handed over. Communities should also be given some incentives for proper upkeep of water systems.

The major task however is to create a sense of ownership and awareness that it is in their own interest to assume full responsibility for maintenance of their RWSS structures. They need to comprehend the importance of keeping the water systems in working conditions to ensure uninterrupted water supply and better health. This requires institutional structures, which allow them to have legal ownership. It is important to mutually agree in a participatory assessment on the most appropriate institutional model. This process will lead to a far-reaching institutional sector reform. The transition of responsibility for management of water supply systems from the governments to the local bodies has to include strategies that allow a smooth changeover during which all partners can build up the capacity to fulfil their new roles and at the same time to safeguard the achievements of the past.

### **7.1.2 Restructuring government departments**

Restructuring of government structures is needed. These departments were primarily executing agencies to construct and maintain water schemes. They are adapted to deal with technical aspects but are normally not well trained/organised to address software issues. It is important to examine their strengths, weaknesses, to review their system, organisational structures and procedures, to analyse their staffing pattern and decision-making processes. This investigation should form the basis for the definition of their future roles in a comprehensive system pursuing community based, demand driven RWSS projects. Full transparency is needed to avoid insecurity among the government staff; otherwise, they see decentralisation as a threat. The process has to take into account the human factor that naturally resists any change. If resistance develops among the staff, the whole concept is seriously endangered.

Decentralised O&M aims at reducing the overall government spending for maintenance. Care has to be taken that real savings are achieved. For this

purpose, the excess staff should be trained in new disciplines to meet the growing requirements. Sensitisation of government functionaries will be another important activity to make application of DRA a success.

## **7.2 O&M - costs and strategies**

It is generally agreed that the running costs for O&M can be fully recovered from revenues collected by the villages. The limitations however are:

- (a) Major repairs might be beyond the technical capacity of the village or area mechanic and well outside the financial capacity of the community,
- (b) Depreciation cannot be achieved, cost for replacement of pumps and extension of systems is too high for communities,
- (c) Borehole maintenance requires specialised skills and equipment.

Sharing of responsibilities and costs between the government and the villages might be a pragmatic approach. In order to arrive at an operative cost sharing system, constant interaction between the communities, the government and the private sector (as provider of goods and services) is necessary. The communities should be obliged to maintain the water systems when they take over ownership. They are normally willing to assume their share and are quite capable and willing to manage O&M in the first few years. But how do they cope after several years, when the system is old and worn out and daily maintenance cost reach exorbitant heights? In order to keep up the momentum it is necessary to establish a constant monitoring and advisory service.

Successful introduction of community management on a sustained basis requires that:

- (a) The water systems are reliable for a long period of time, and the water quality is acceptable to the people.
- (b) The necessary back up services (spare parts, repair services, technical support, etc.) are accessible at short notice and in the vicinity.
- (c) A monitoring system of O&M is established and advisory support is provided to the villages.
- (d) Provisions are made for repairs beyond the capacity of communities, like well maintenance, rehabilitation/extension, etc.

### 7.2.1 *Cost of maintenance*

The cost of maintenance is often quoted without reflecting the full cost, this includes cost of spare parts, distribution, transport, labour, cost of establishment of support organisations, etc. Many of these cost items are difficult to quantify, as for instance a community member might travel a full day to buy spare parts and would not calculate the cost for lost labour and travel. For the sake of simplicity, most studies try to separate these aspects and calculate only the cash contribution a community has to make, i.e. repairs and spare parts. Costs for O&M range from about USD 0.10 (for direct action handpumps) to USD 2.50 (for diesel pumps) per capita and per year.

The cost analyses normally exclude depreciation, that means the cost of rehabilitation and replacement of equipment are not counted. Since these costs are often covered under development budgets, this would seem to make sense. At macro level, it would however also be necessary to look into the economic costs of rehabilitation.

The cost paid fully by the communities is only one component of the total O&M cost. In addition to this part, it is necessary for governments or district authorities to budget for back up services i.e. extension/supervision, well maintenance, etc. The fact that the private sector can be used to provide some of these services has a rationalising effect.

### *Preventive maintenance*

The cost effectiveness of preventive maintenance is beyond doubt. Breakdown maintenance prevails under community management; preventive maintenance is virtually not done. Sustainable preventive maintenance requires a complete behavioural change and will only be accepted to a very limited extent. It is important to introduce a monitoring system under which the communities are motivated to make the necessary repairs in time.

Systems that require a higher level of maintenance (diesel pumped systems, reticulated systems) a privatised O&M arrangement under which a company or a water user group operates the water facilities could ensure the necessary level of preventive maintenance. Such a private operator can

organise tariff collection and take on the role of the executing agency for O&M.

### 7.2.2 *O&M strategy*

A model for a successful maintenance strategy could include the following key aspects:

- a) Standardisation of equipment to keep the number of pumps and spare parts to a minimum.
- b) Introduction of a continued annual preventive maintenance and inspection service. Communities sign an agreement that they will have the facilities inspected by an approved private mechanic on a regular basis. During these inspections, fast wearing parts are exchanged. Communities will have to pay the mechanic for this service.
- c) Communities also pay a nominal monitoring fee into a water fund controlled by the district authorities.
- d) The communities pay any other repairs and additional spare parts, which become necessary between the inspections.
- e) The district water authorities permanently provide O&M support by advising and motivating the communities. They supervise the private mechanics and provide a link between them and the community. They maintain the district database of all water facilities. O&M technicians can be recruited from water department personnel that become redundant under the new sector policy.
- f) The district authorities ensure back up for major repairs that are well outside the technical and financial capability of the communities. The private sector can be invited to tender for service contracts and borehole cleaning and redevelopment (see below).
- g) Identification of what services can be privatised. Franchising of some of the services to NGOs or private companies, which are acting on behalf of the districts should be considered.
- h) District personnel are trained on all technologies.
- i) Financial assistance (district water funds) to the communities in case of a major repair or borehole rehabilitation. The district authorities can grant soft loan credits for the repairs to communities eligible for assistance if they have they paid their fee to the district water fund and have had the annual inspections carried out.
- j) Assistance to the private sector to develop a network for after-sales services provided by trained mechanics and supply of spare parts.

- k) Training of community pump mechanics, area mechanics and O&M Technicians by suppliers.

### **7.3 Private sector involvement in O&M**

As said earlier, suppliers of handpumps and equipment should be compelled to set up their own after-sales service network. They establish regional sales centres equipped with the necessary tools and spares and appoint area mechanics as district representatives. These area mechanics are small entrepreneurs who inspect, maintain and repair handpumps. Although regular inspections will provide a basic workload, the economic base of such a job is not sufficient to support a mechanic full time. The suppliers will have to utilise small enterprises that are already operating in a related field (car/motorcycle mechanics, household article repairers). It might be worthwhile looking at the already existing capacity in the private sector. In many countries, the maintenance requirements of irrigation boreholes are met by the private sector. It should be possible to give this already established capacity a reasonable and responsible share in the O&M work for drinking water.

In order to perform the (preventive maintenance) inspections, the area mechanic need to be certified by the district authorities. For this, he will have to undergo the specified training. The training of area mechanics would be left to the supplier under the guidelines for pre-qualification.

The facilitating and regulating roles have to be retained by government agencies. The institutions at national, regional and district will have to assume the assignments of co-ordination, planning, monitoring and direction. These roles: the authorities, the responsibilities and the ways in which these tasks can be performed need to be defined. Water resources management cannot be left to individual communities when competitive use for domestic water supply, industry and irrigation becomes an issue.

### **7.4 Spare parts distribution**

Spare parts supply for pumps (specifically handpumps) in rural water supply is the weak link

in the chain of after sales services. Hardly anywhere, has satisfactory spare parts distribution been achieved. Selling of spare parts is generally not a profitable business. Turnovers are too small; and the components that need to be kept in stock are many. Therefore the willingness of the private sector to take up this commercially uninteresting activity is minimal.



**Figure 50** *Street sign spare supplies*

As mentioned above, pre-qualified suppliers have to set up a network of spare parts outlets. Theoretically, the distribution network could have the following appearance:

- (a) The national supplier keeps sufficient, fully comprehensive stocks of all spares in his central store.
- (b) In each region, the regional dealer keeps adequate stocks of spare parts. Models in which the financial risk is shared between the national supplier and the regional dealer need to be worked out. The quantity of spare parts in stock should be sufficient to cover at least 80% of all breakdowns. In the case where the components

are not in stock with the regional dealer, it should be possible to order the parts within one week from the national supplier. The regional dealer sells the spare parts either directly to communities or through an appointed area mechanic. The bulk of the spare parts sales are components replaced during the (preventive maintenance) inspections. This allows the regional dealer to plan closely the annual turn-over of spare parts.

- (c) The area mechanic is the principal outlet for spare part sales. He makes the annual inspections, replaces the fast wearing parts. He has a margin on all spares sales. He might stock only the parts that he has to replace during the inspection. Any other spare part required for repairs, he orders from the regional dealer, thus making it available in less than a week.
- (d) The government prepares a list of recommended spare parts sales prices for all the standardised pumps. This list will be reviewed and agreed on annually together with the pre-qualified suppliers/manufacturers. If the price list is published, the communities will know how much a spare parts costs.

Experience tells that such a system might not be sustainable in many rural areas in Africa. The after sales structures tend to break up soon after the sales of pumps drop when an investment project is completed. In order to make the activity attractive it will be necessary to bring incentives other than the direct financial gains. It might be useful to augment the financial viability through corporate sponsorship for rural water supply. Sponsoring of spare parts supplies for rural water could be attractive to big companies for advertising. The challenge will be to sell new, unconventional ideas to such companies.

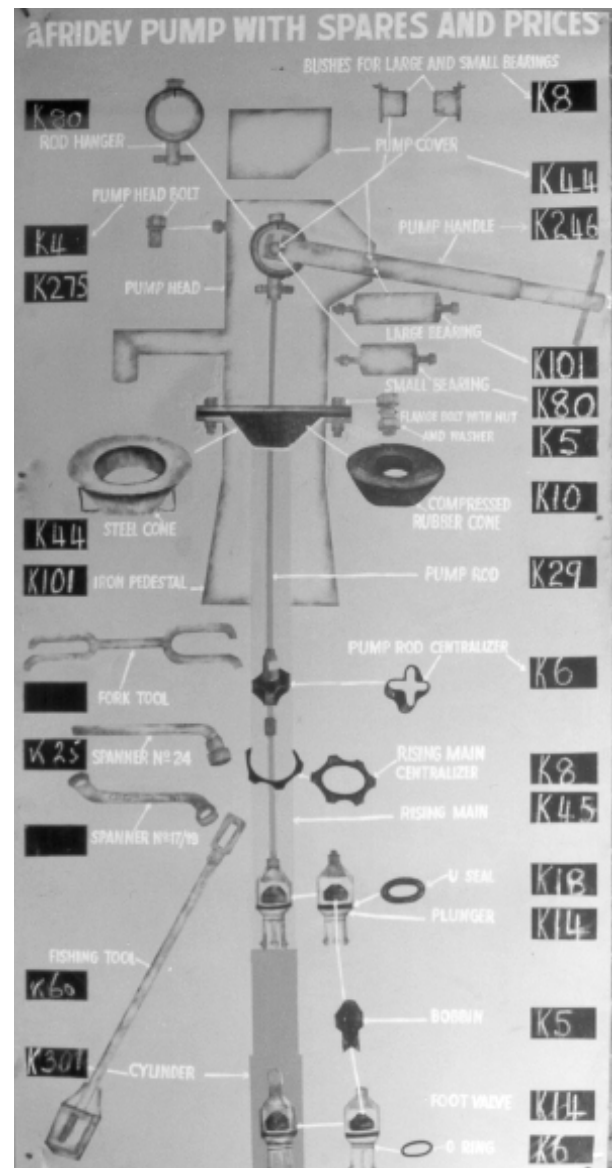

Figure 51 Pricelist spare parts

## 8. *India handpump case study*

### 8.1 *Introduction*

In the year 1967, UNICEF responded to the drought in Uttar Pradesh and Bihar by bringing eleven 'down-the-hole' (DTH) pneumatic drilling rigs into the country. This started the Indian handpump revolution. The arrival of these rigs initiated a programme that was to become the largest of its kind in the world, in terms of both area covered and people served. The Government of India has made the provision of clean, safe drinking water a cornerstone of its rural development programme. The rural water supply programme covers approximately 600,000 villages, serving almost three-quarters of India's 1,000 million population.

This case study looks at the handpump development in India from the early 1970s to end 1990s and tries to critically review the implementation approaches in research and development, standardisation, capacity building, quality assurance and procurement. It also highlights the importance of proper technology selection, standardisation and quality control.

It analyses the complications maintaining such huge numbers of assets and how India tried to react to these challenges with the development of the India MKIII designed for easy maintenance and repair. The study offers an outlook towards new strategies of decentralisation and community management.

### 8.2 *The India MKII success story*

#### 8.2.1 *Emergence of a new pump*

In 1967, the pneumatically operated drill rigs increased the output of boreholes. The pumps fitted on them were of the cast-iron 'family' pump type used in American and European homesteads. Designed to meet family needs, the pumps were breaking down under operating conditions in which

they had to operate almost continuously for more than 10 hours a day. NGO's in Jalna and Sholapur designed new improved pumps with a single pivot handle and sealed ball bearings. The connecting rod was kept aligned and in a state of constant tension through a chain running over a quadrant. A pedestal fitting over the borewell-casing pipe ensured a sanitary seal and the pump was set in concrete to eliminate movement. Several hundreds of these Jalna Jalwad and Sholapur pumps were produced over the next few years.

Little co-ordination took place so that the pumps were invariably different from each other and even more serious, pump components of the same design were also not interchangeable. This made O&M rather difficult.

Excerpt from a report by Ken McLeod, UNICEF 1977:

*"For the sake of this record, it is not necessary to detail the problems, existent, within the programme in 74, save to say, that the situation was bordering on disaster, and the drilling programme, UNICEF's prime responsibility, was in danger of being nullified, if a durable handpump could not be supplied...."*

#### *The association of UNICEF*

Water supply and environmental sanitation were important components of UNICEF's Integrated Country Programme. In 1974, UNICEF carried out a survey of handpumps fitted on bore-wells. The results were not encouraging, about 75% of the cast iron handpumps were inoperative. In the Bangalore workshop on handpumps in 1974, these unacceptable results were presented and UNICEF even considered stopping its support to the borehole programme because of the high failure rate.

To meet the requirements of rural India, a partnership between two GOI organisations, the

Mechanical Research and Development Organisation (MERADO) and Richardson & Cruddas, both in Madras and UNICEF started for the development of an improved handpump, the India MKII (there was never a MKI pump). UNICEF played a key role acting as a co-ordinator and facilitator in the development work of the India MKII. MERADO provided design support, while Richardson & Cruddas were responsible for manufacturing the various prototypes. The partnership that evolved was quite unique as the Indian partners invested considerable financial and manpower resources without ever entering into a contract with UNICEF. The Handpump Project was based on the mutual understanding that India needed an improved handpump and that all parties would work towards this goal. It was also clear, that once the research work was finished, the design would be made available in the public domain.

The Handpump Project focused on:

- (a) Development of a sturdy and reliable community handpump,
- (b) Large-scale local production in simply-equipped workshops at low cost,
- (c) The use of materials and components available in the country;
- (d) Reducing pumping effort to minimise the burden on women,
- (e) Demonstrating that a better-designed handpump, standardisation and quality control could facilitate a more effective maintenance system,
- (f) Demonstrating that a more reliable supply of potable water could reduce the incidence of water-borne and water-related diseases.

The Sholapur pump remained the point of reference during development of the India MKII. In 1975, UNICEF purchased 6,500 Sholapur 'conversion heads' and provided them to various state governments. The 'conversion heads' (or top part of the Sholapur pump) replaced the multi-pivot handle of the cast iron handpump. The successful outcome of this hybridisation changed the Government's attitude towards the handpump as a source of water in rural areas.

To achieve these various above objectives, the research and development team made the following design changes:

- (a) Increasing the pedestal diameter from 5" to 6" to accommodate the 5" casing,

- (b) Replacing the pipe handle with a solid bar, to counter-balance the weight of the connecting rods,
- (c) Replacing the two-part Sholapur design (head with water tank and pedestal) with a three-part modular design (head, water tank and pedestal).

Field-testing was carried out in 1976-1977 in the Coimbatore district of Tamil Nadu State under the joint supervision of the Tamil Nadu Water Supply and Drainage Board and UNICEF. The combination of a deep SWL (around 40 metres) and a high handpump usage pattern made the district an ideal testing-ground. Another 1,000 pumps manufactured by Richardson & Cruddas were put on trial in various states in December 1977. The results were very encouraging; the pumps had a very low breakdown rate, were easy to operate and widely appreciated by communities and Government. With the extensive testing programme completed, it was now time to introduce the new pump in large numbers.

### ***8.2.2 Large-scale production***

The improved pump design found acceptance by the Government of India and a number of state governments. Demand started to rise. India needed to set up quickly a mass production capacity for handpumps. By 1978, Richardson & Cruddas manufactured about 600 India MKII per month.

UNICEF helped to identify and develop new manufacturers. It focussed on co-operation with established private companies to achieve a quick production base and tangible results. Crown Agents was engaged to carry out works inspection at potential manufacturers. These inspections served to verify the technical and financial capability of the companies that had applied to become India MKII manufacturers. Once competence was ensured, trial orders were placed with these companies. UNICEF and the inspection agency provided technical assistance to manufacturers for setting up production processes and in the jig and fixture design. It was mandatory for manufacturers to establish a functional internal quality control management. This process enabled many of the private sector companies to improve their production and in-house quality control systems. They became qualified as UNICEF approved handpump suppliers.

The pragmatic policies pursued and promoted by UNICEF, on standardisation, local capacity building and quality assurance paid rich dividends and within a few years the handpump programme expanded phenomenally. The private sector's response to meet demand for handpumps was excellent. R&C, INALSA, Meera & Ceiko Pumps and Ajay Industrial Corporation soon became major players in the handpump industry, in India and abroad. The total production capacity reached over 100,000 units by 1982. By 1984, more than 600,000 handpumps had been installed and, in 1998, some 3 million India MKII handpumps provide water to the rural and urban population across India.

By 1984, UNICEF had licensed 36 approved manufacturers; the annual production capacity had grown to over 200,000 units. All the qualified manufacturers had undergone rigorous works inspections for assessment of their capacity and capability to meet the stringent standards. In 1996, the Bureau of In-

dian Standards (BIS) took over the task of issuing production licenses. The number of BIS licensed manufacturers has reached 62 by the year 1998. They have a total annual production capacity of over 300,000 handpumps.

### 8.2.3 Standardisation

A focus for the quality of the product was always in the forefront in the development of the India MKII. The problems of non-standardisation had become apparent during the prototype testing of the India Mark II. Many imitations, virtually all of a substandard quality, had appeared in the market. In 1976, the Central Public Health and Environmental Engineering Organisation (CPHEEO) in concurrence with UNICEF took a decision to formulate a national standard. The drawings and specifications of the handpumps were given to the Indian Standard Institution (ISI), now the Bureau of Indian Standards (BIS), so that it could prepare a national standard

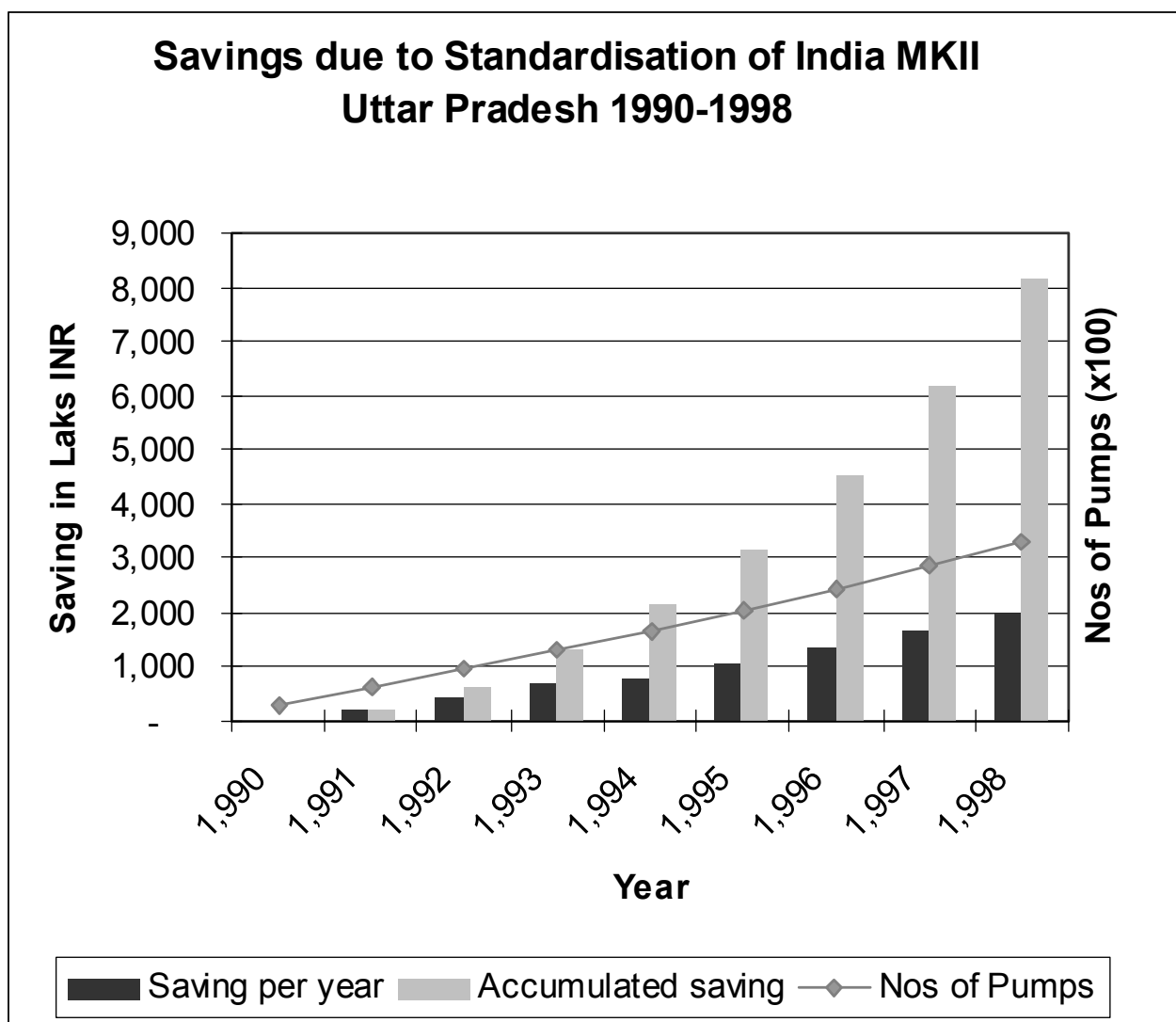



on the handpump. The National Conference on Deepwell Handpumps, sponsored by the CPHEEO and UNICEF, held in 1979 at Madurai, Tamil Nadu, endorsed the need for standardisation and strict quality control.

In 1980, the first ISI Specification for Deepwell Handpumps IS: 9301-1979 was issued. The process of national standards formulation was flexible enough to be responsive to the needs of the field. Work on refinement of the technology continued to improve reliability, durability and ease of maintenance. Any change in the standard was accepted only after it had proved its field worthiness. The ISI reviewed and modified the standard in 1982, 1984 and 1990.

The co-operation between UNICEF and the national Bureau of Standards created the necessary author-

ity for the efforts by UNICEF to maintain quality. The effect of standardisation and the private sector production of handpumps lead to fierce competition, which brought prices of pumps and spare parts down considerably.

### 8.2.4 The India MKII in the export market

Although the India MKII was primarily designed for Indian rural conditions, it soon found its way abroad. The India MKII went on to conquer export markets. Indian manufacturers successfully competed in international markets. Over the years, they became the main suppliers of handpumps to the African continent. The combination of a sturdy product, manufactured to a high quality standard at a competitive price opened the possibility for the Indian producers to secure global tenders.

## Handpumps in India

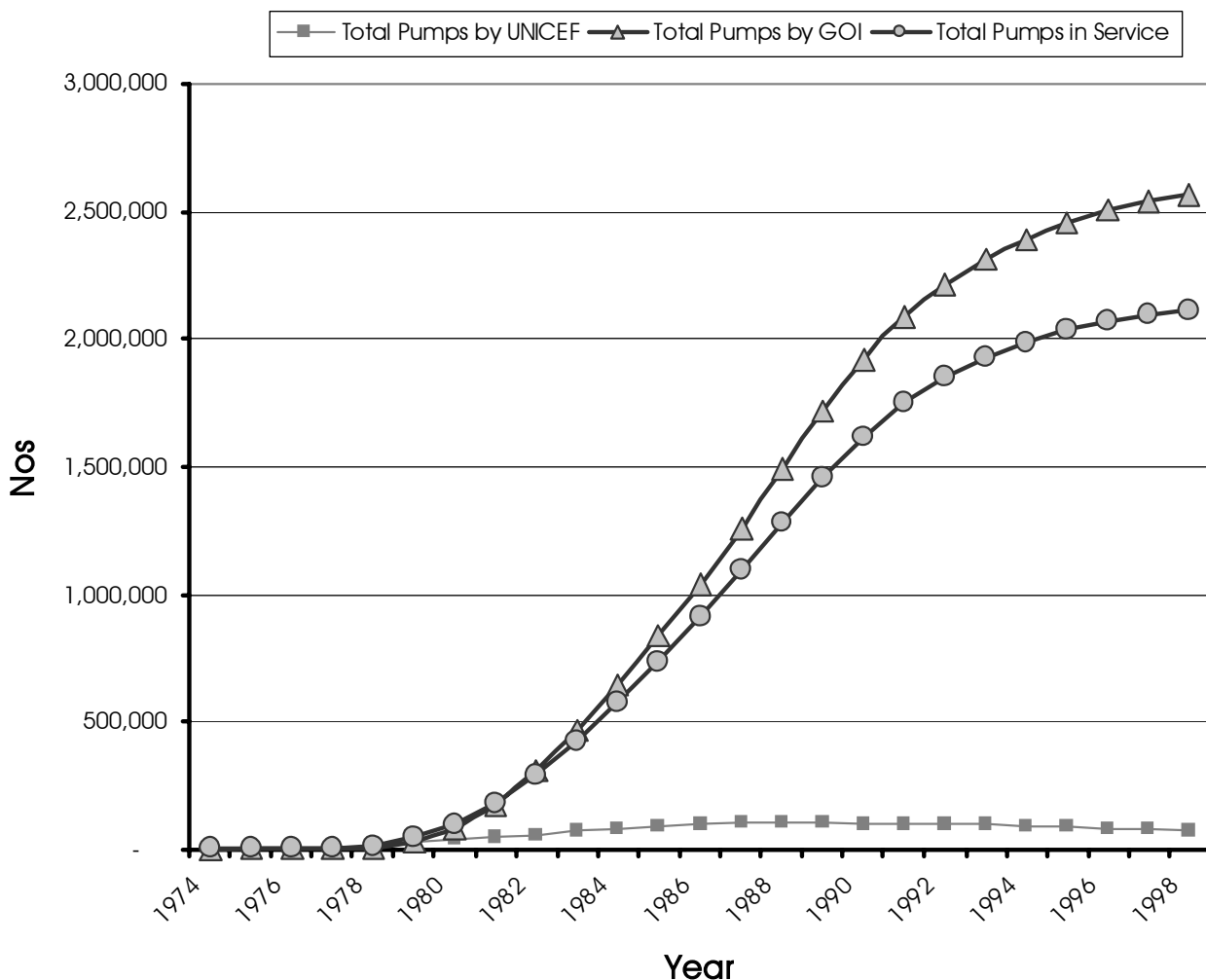

Production of India MKII pumps started in various countries outside India e.g. Germany, Italy, Mali, Togo, Nigeria, Uganda. Countries like Nigeria, Uganda, Ghana, Mali, Sudan included the India MKII pump in their national standardisation programme.

### 8.2.5 *Accomplishing quality*

A key factor to the success of both the domestic handpump programme and the export sales of Indian handpumps was UNICEF's strict commitment to quality and the effective partnership with BIS. It was realised that large scale manufacture of India MKII pumps in many different companies would have the great potential of bringing prices down due to competition. At the same time, it posed a serious threat to the product as well. To counteract this potential problem, UNICEF insisted on strict quality control of all pumps to ensure longevity and inter-changeability between pumps and parts produced by the various manufacturers. It arranged and paid for pre-delivery inspections of all handpumps purchased for GOI by independent inspection agencies (Crown Agents and SGS) over a period of fifteen years. The technical support provided to manufacturers was instrumental to economically produce handpumps of adequate quality in India.

In 1996, the full responsibility for quality control was transferred to the BIS. Recognising the need for continued quality, government departments purchase only from BIS approved manufacturers with pre-delivery inspections at the manufacturer's works by a BIS inspector. The state governments pay for the inspection cost, which is now included in the purchase price of the handpumps. By end of 1998, UNICEF had stopped supporting spare parts inspections. For spare parts supply the BIS issues self-inspection licences to manufacturers under a self-marking scheme i.e. those parts are not any longer subject to third party inspection.

Despite these efforts, it is difficult to maintain the quality standards. Many manufacturers feel that UNICEF's withdrawal from inspection and quality control has been a discernible step backwards. Maintaining acceptable quality is a big challenge. Three million India MKII pumps of good quality are a tremendous asset, however if the quality standards drop, huge numbers of inferior quality pumps could be a colossal liability.

### 8.2.6 *Government's role*

The Government of India (states governments and the RGNDWM in implementing the ARWSP and the MNP) played a crucial and decisive role in the accomplishment of the handpump programme strategy. The attached graph shows the significant part played by GOI in this programme to achieve coverage for the rural population. UNICEF support was catalytic in nature and shifted from the initial hardware demonstration towards mainly software inputs. The government's strong support of standardisation and quality control was crucial for the handpump programme in India to accomplish the tremendous task of providing safe water to most of the rural population.

The GOI has realised that the days of striving for numbers have ended. It is now essential to manage the assets that were built up over the last 20 years. To improve, expand and sustain the existing infrastructure will be another formidable task.

## 8.3 *Technology development for change*

### 8.3.1 *Involving the users*

Community based O&M of handpumps had been under consideration on the very beginning of the India MKII development.

Ken McLeod wrote in 1979:

*"New concepts are being developed overseas and we will submit them to field testing, as and when they become available. A concept shortly to be tested in our application is the cylinder that allows for the removal of the piston and foot valve without removal of the rising main..... This concept, if proved to be reasonably durable and by this we mean one year's trouble-free operation, could bring village maintenance in sight."*

The VLOM-concept centred initially very much on the development of so called VLOM handpumps. The development of the India MKIII pump falls into this era. The line of thinking was that easy to repair handpumps would automatically trigger community involvement. Only with time, it became apparent that the VLOM-concept depends much less on

technology and rather more on software and institutional aspects.

### **8.3.2 The India MKIII development**

The UNDP/World Bank's Handpump Project and UNICEF supported a field-testing project near Coimbatore in Tamil Nadu. The objective of this project was to carry out improvements on the India MKII. The project developed and field-tested two handpump designs, the India MKII (modified Deepwell Handpump and the India MKIII (VLOM) Deepwell Handpump. Development work to improve serviceability had to be carried out without adversely affecting the inter-changeability of the components, reflecting the large number of pumps already in the field.

In the India MKIII, an open top cylinder and 2½" galvanised iron riser pipe were fitted. The above ground mechanism was modified to facilitate withdrawal of the extractable piston and foot valve without having to remove the rising main. The foot valve is placed in a conical receiver and a nitrile

rubber O-ring provides sealing. A push rod in the footvalve purges the column of water when the foot valve is lifted; thus, retrieval becomes much easier.

### **8.3.3 The rationale behind the India MKIII development**

The Coimbatore Project made a wealth of data available, comparing India MKII and MKIII pumps. The data indicated that repairs to the India MKIII took 67 % less time than for the India MKII. Difficult repairs, which required a mobile team, were 86% less. The tools (weighing approximately 7 kg) were sufficient to perform 90% of all repairs. The costs for O&M depend on the following factors:

- (a) Type of maintenance structure,
- (b) Number of pumps a maintenance structure can look after,
- (c) Number of interventions per year,
- (d) Cost of parts replaced.

The maintenance cost of the India MKIII was calculated to be \$ 23.50 per annum less than the India MKII. The reduction is mainly due to the cost of the mobile teams being reduced by 66%.

## **THE VLOM CONCEPT**

The inter-regional Handpump Project (later named Water and Sanitation Program) initiated in 1981 by UNDP/World Bank in support of the international drinking water decade was the major promoter of the Village Level Operation and Management of Maintenance (VLOM) concept. It was seen as the most suitable approach to the maintenance problems.

Initially the Handpump Project aimed to develop a new generation of better handpumps. However, field trials indicated strongly that technology did not solve problems related to handpump breakdowns. Pumps were not repaired for many reasons, missing mechanics, missing tools and spare parts, non-availability of vehicles or lack of fuel.

A careful appraisal of the inter-linked obstacles surrounding handpump maintenance systems led to the conclusion that handpump technology had to be 'user-friendly', that the villagers, with a minimum of training, should be able to work as handpump mechanics. The design philosophy aimed at a pump that could be put back into service with little effort and minimal administrative overhead.

In the beginning, the VLOM idea restricted itself to the hardware aspect, with the intention of developing pumps that were:

- manufactured locally, thus ensuring the availability of spare parts;
- maintainable by a village caretaker with minimal skills and a few light tools;
- sturdy under field conditions;
- cost effective.

These objectives contained within them the inherent need for organising an enabling environment within which the people and their pump could interact. The software element became prominent and very important. Community participation and management took on a sharp definition. The responsibility for O&M of the pumps was now at village level.

Further, community based O&M has the potential to shorten the downtime of the handpumps. A survey noted that the time taken to report a breakdown varied from 4 to 13 days. The time taken to put the pump back in operation varied from 7 to 44 days after the receipt of the report. Approximately 80-85% of the handpumps are operational at any time. That means in average a pump is out of service for approximately 50-70 days in a year. If users can repair their own pumps, the problem of long delays could be mitigated largely.

The capital costs of an India MKIII are 36.3% higher than that of the India MKII, excluding the cost of borewell and platform, mainly due to the bigger sized rising main. In India, the initial costs are a very important consideration in the selection of equipment. Higher capital expenditure can be justified only if it can be offset by lower recurring maintenance costs and other advantages.

## 8.4 Changing course

The arrival of the INDIA MKIII was probably essential to initiate the shift in government thinking. The India MKIII being easy to maintain at village level encouraged the philosophy that communities could take charge of their pumps. The convincing figures from the Coimbatore project indicated that the higher investment cost of the MKIII appeared to be justified.

Demonstration projects of Community Based Handpump Maintenance (CBHM) using MKIII were started in Bihar, Andhra Pradesh, Madhya Pradesh and Maharashtra. The projects mainly concentrated on the training of communities, particularly women, in performing the necessary repairs and (sometimes) inclusion of Gram Panchayats into the procurement of spare parts. However, the full potential offered by the Panchayati Raj system to establish clear legal community ownership of the waterpoints with new roles for the technical departments and the rural development departments was not explored. Spare parts still had to be obtained through the old government channels.

As CBHM demonstration projects were not part of a full institutional reform, the structures at PHEDs/boards and at the district/block level did not change.

Obviously, the engineers see CBHM as a threat to their jobs. With the lack of perspective within the departments, the India MKIII never found wide acceptance. The technical limitations (because of the weight of the rising main pipes the pump could not be used in installations deeper than 30 m) further reduced the impact.

### 8.4.1 *Has the MKIII been a step in the right direction?*

Has this pump actually achieved its objectives? In terms of factual improvement of the reliability of the handpumps, it was certainly a small step forward. Ease of maintenance is not a decisive factor for the O&M of handpumps. Village communities who can maintain their diesel/electric irrigation pumps are well capable of repairing a handpump, whether it is MKII or MKIII. The felt need to have an operating pump is the deciding factor and this is mainly linked to ownership and commitment.

On the other hand, sometimes a good idea needs a tangible piece of hardware to go with it. From this point of view, the India MKIII has probably been a very useful tool for the advocacy of community based maintenance at all levels.

The MKIII did not accomplish its goal:  
***“to stand in the village and invite, perhaps challenge, the community to participate, to maintain, to manage”.***

It did however trigger off a different development:

***“the GOI started to believe that alternatives to the established three-tier maintenance concept are feasible.”***

From this point, the real merit of the MKIII development is hidden in the diameter of the rising main. It opened a door and the GOI seized this opportunity and works now on the development of a fully comprehensive decentralised maintenance concept.

## **8.5 Maintaining the assets**

### **8.5.1 Relevance of handpump programme**

By 1999, an estimated 3.0 million India MKII/III handpumps has been installed in rural India, serving a population of approximately 500 million. The number of boreholes and handpumps represent an investment of approximately 150 billion INR (or USD 40 billion). A study commissioned by UNICEF in 1985 found, on average, 87% of the pumps were working at any time. This figure stands in stark contrast to an assessment in the 1970s when the breakdown rate was so high that only 25% of the pumps were working. The presently reported results of handpump performance vary from 98% operational at any time to about 60%. These figures may well be too optimistic, it can be safely assumed that about ~65% of the pumps are in working condition.

Progress in rural electrification allowed the provision of a higher level of service through small piped systems. The handpump is increasingly a supplementary water supply system that is used as standby in case of a pumped scheme failure. The relevance of the handpumps is diminishing in India.

It should however be noted that the rapid progress of the ARWSP and MNP increased the water supply coverage of rural communities within the last 18 years from 31% to nearly 90%. With this increasing number of water points, the cost to maintain them rose rapidly as well. Presently the cost to the government for the O&M of 3 million boreholes with handpumps is approximately 3,000 million rupees (USD 75 million). The burden on the government is very high and might not be sustained for much longer. In the new Guidelines for Implementation of Rural Water Supply Programme (1999), the RGNDWM plans to set up an effective cost sharing arrangement.

The designers of the India MKII had attempted to create a veritably robust machine. They had deliberately tried to reduce the frequency of maintenance interventions. The question of ease of repair was not an important design consideration. Thus, for all its simplicity of design and durability, the India MKII did not offer the user the opportunity of a 'hands-on' approach to handpump maintenance. The India MKII

designers had assumed that when necessary, competent professionals would be called in from the district headquarters or from the Public Health Engineering Department (PHED) to repair the pump.

### **8.5.2 The three-tier system**

The National Conference on Deepwell Handpumps held at Madurai in 1979 was a significant landmark for handpump maintenance. It recommended the presently predominant three-tier maintenance system as a workable solution for handpump O&M. It offers the users a rudimentary opportunity to participate in the responsibility for O&M. The system consists of:

- (a) Village caretaker,
- (b) One block-level mechanic who looks after 100 pumps, and
- (c) One mobile repair team at district level for every 1,000 pumps.

The intention was for the handpump caretaker to work on a purely voluntary basis and to keep pump surroundings clean and to report breakdowns.

### **8.5.3 Practical experience**

The three-tier maintenance system was adopted in nearly all states. It appears that in practice, only the two tiers on top (i.e. the block-level mechanics and the district mobile maintenance teams) were effectively established. The system with the voluntary caretakers never really worked well; high dropout rates effected that soon many of the caretakers had given up their responsibility. This adversely affected the reporting of handpump failure to district/block level officials.

The complicated institutional setting with two agencies responsible for handpump O&M, (the technical departments are responsible for the installations and the major repairs but the Panchayats are responsible for day to day O&M) does not help to make the situation more transparent. In reality, the three-tier system has been replaced by a one-tier system in which the mobile teams have to carry the main burden. They can only react to reported breakdowns and have no possibility of carrying out preventive maintenance. The norms set for the three-tier system, (i.e. (a) one block-level mechanic for 100 pumps, (b) one mobile team for 1,000 pumps and (c) one hydrofracturing unit/compressor per

30,000 boreholes) are not sufficient to allow a fully comprehensive coverage of all pumps with mobile teams. A mobile team can in average attend to about 3 pumps per day. This would bring the theoretical total pump repairs to about 860 per annum. In reality the total number of repairs will be less due to various reasons (truck not available due to maintenance, idle time due non-availability of crew, truck being used for other purposes, etc.). The realistic number of pumps covered by a mobile team would be approximately 500. The lack of maintenance personnel and transport effects that the repair services cannot be carried at the planned level. Frequently, it takes a long time between reporting of the breakdown and the arrival of the repair unit.

Despite an institutional environment that is not conducive for effective O&M the pump, performance figures are quite good. This can be attributed to the following factors:

- (a) Norms set for handpumps (250 people) are realistic,
- (b) The India MKII is a good pump (in design and quality),
- (c) Level of competence and commitment within PHED's is high,
- (d) The political will to provide water to rural population is strong.

However, the three-tier system is relatively expensive, and also lacks responsiveness, in terms of time and occasionally inclination.

#### **8.5.4 Community based handpump maintenance**

The RGNDWM conducted a national workshop on community based O&M in RWS in 1997. Since then several states have taken the idea up and run workshops on the same subject. These workshops provide a very useful platform to discuss the concept in a participatory manner with state level government officials, in order to define the future role of the governmental structures and to formulate action plans for the transition. The mission realised the need for change. The main thrust of the ARWSP is not any longer on numbers and coverage but it strives rather for quality of the systems. Now that India is moving towards decentralisation (9<sup>th</sup> 5-year plan), the mission included community based O&M in the Guidelines for Implementation of Rural Water

Supply Programmes (1999) as the way for the future. The RGNDWM's methodology for implementation sets the conditions for community based O&M, it includes the need for communities to:

- (a) Own the assets,
- (b) Be involved at all stages in the planning, implementation/development and maintenance of the facilities,
- (c) Be trained to do simple repairs,
- (d) Know that the government will not maintain the assets,
- (e) Have sufficient funds for maintenance,

These changes are an effective step forward in introducing CBHM. India has theoretically the ideal institutional set-up for decentralisation of O&M. The implementation of CBMH including all aspects (change of institutions, legal ownership, technical back up, financing including cost sharing, etc.) by Panchayati Raj Institutions/local communities, water user committees, NGOs will be supported through special incentives to institutionalise community participation.

It should be noted that CBHM will not reduce cost significantly. The cost per handpump for O&M will remain about the same, however down time can be greatly reduced. In contrast to the centralised system, where all the financial resources come from the government, it offers the possibility to introduce an effective cost sharing arrangement and accountability.

The vigilant implementation of the new guidelines by RGNDWM will empower the communities to plan, build and maintain their water systems. For many years to come handpumps will remain their principal source of safe water.



**9.**  
***Handpump fact-sheets***



## 9.1 No 6 Pump

### Description

The No 6 Pump is lever operated Suction Hand-pump. Typically, No 6 Pumps are installed in collapsible tube wells with the screen extending to the coarse sand aquifer. The pump head and the handle are made of cast iron. Pump rod and axles are made of mild steel. The piston assembly is made of brass with a plastic bucket seal. The suction pipe and the robo screen are of PVC pipes. This makes this pump reasonably corrosion resistant.

### Technical data

Cylinder diameter (mm):	89.0
Maximum Stroke (mm):	215
*) Approx. discharge about 75 watt input m <sup>3</sup> /h:	
at 5 m head	4.5
Pumping lift (m):	0 – 7
Population served (nos.):	50 – 100
Households (nos.):	5 – 10
Water consumption (lpcd):	20 – 25
Type of well:	collapsible tubewell (or dugwell)

### Material

■ Pump head	cast iron
■ Handle	cast iron
■ Pump rods	mild steel
■ Suction pipe	PVC pipe
■ Cylinder	cast iron
■ Plunger/footvalve	brass

### Local manufacturing

The No 6 Pump has an excellent potential for local manufacturing.

### Installation

The installation of the No 6 Pump is easy and does not need any lifting equipment or special tools. The drillers who sink the tube well with the "sludger method" also install the pump.

### Maintenance

This pump has an excellent "Community Management Potential". Only two spanners are needed to repair the plunger and the footvalve. A village caretaker can perform all maintenance operations.

### Remarks

This pump is like all Suction pumps limited to pumping lifts of a maximum of 8 m. It is recommended not to go deeper than 6-7 m. The No 6 Pump is not designed for a high daily output, but rather a family or small community pump.

### Suppliers

The No 6 Pump is a public domain handpump. Technical information and a list of recommended manufacturers are available from HTN SKAT, homepage: [www.skat.ch](http://www.skat.ch)

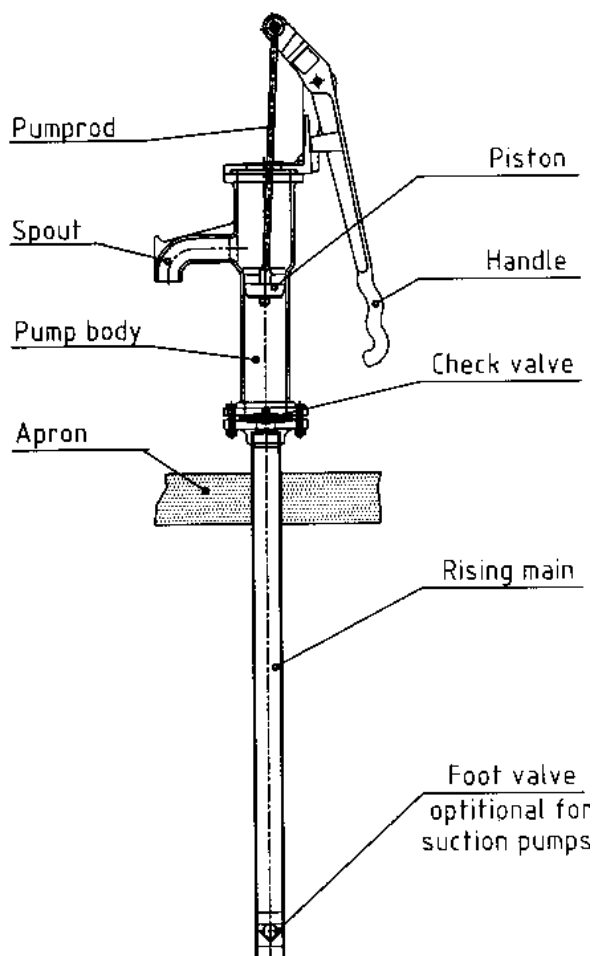

## 9.2 Jibon Pump

### Description

The Jibon Pump is lever action deep set handpump. Typically, Jibon Pumps are installed in collapsible tube wells with the screen extending to the coarse sand aquifer. The pump head and the handle are made of cast iron. Pump rods are made of glass fibre reinforced plastic. The piston assembly and the footvalve are made of plastic and stainless steel. The rising main, the suction pipe and the robo screen are of PVC pipes. This makes this pump reasonably corrosion resistant.

### Technical data

Cylinder diameter (mm):	54.0
Maximum Stroke (mm):	215
*) Approx. discharge at about 75 watt input m <sup>3</sup> /h:	
at 5 m head	3.0
at 10 m head	1.8
at 15 m head	1.2
Pumping lift (m):	0 – 12
Population served (nos.):	50 – 100
Households (nos.):	5 – 10
Water consumption (lpcd):	20 – 25
Type of well:	collapsible tubewell (or dugwell)

### Material

■ Pump head	cast iron
■ Handle	cast iron
■ Pump rods	FRP
■ Rising main	PVC pipe
■ Cylinder	PVC pipe
■ Plunger/footvalve	plastic, different materials

### Local manufacturing

The Jibon Pump has an excellent potential for local manufacturing.

### Installation

The installation of the Jibon Pump is easy and does not need any lifting equipment or special tools. The drillers who sink the tube well with the "sludger method" also install the pump.

### Maintenance

This pump has an excellent "Community Management Potential". Only two spanners are needed to repair the plunger and the footvalve. All maintenance operations can be performed by a village caretaker.

### Remarks

This pump is limited to pumping lifts of a maximum of 20 m. It is recommended not to go deeper than 15 m. The Jibon Pump is not designed for a high daily output, but rather a family or small community pump.

### Suppliers

The Jibon Pump is a public domain handpump. Technical information and a list of recommended manufacturers are available from HTN SKAT, homepage: [www.skat.ch](http://www.skat.ch)

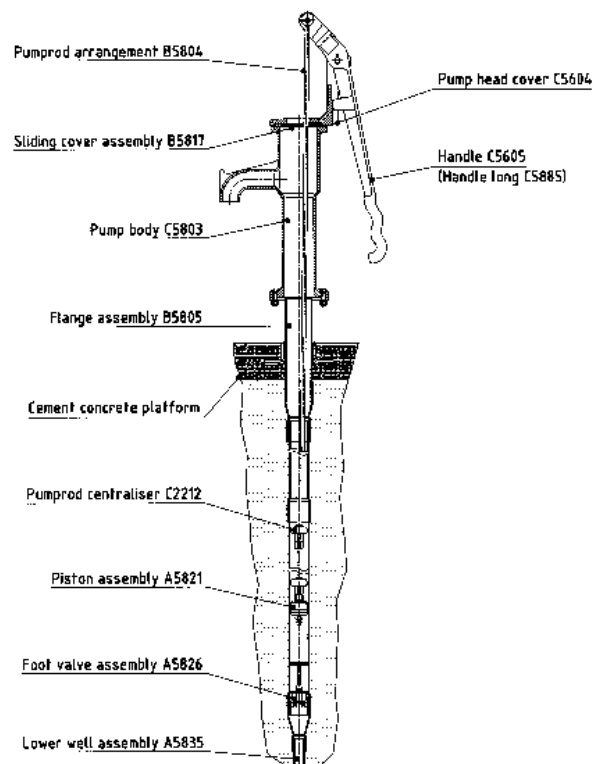

## 9.3 TARA Pump

### Description

The TARA Pump as a Direct Action Handpump is based on a buoyant pump rod that is directly articulated by the user, discharging water at the up- and down stroke. TYPICALLY, TARA pumps are installed in collapsible tube wells with the screen extending to the coarse sand aquifer. The pump head and the handle are made of galvanised steel. Pump rod and rising main are of PVC pipes and the rest of the down hole components are made of rubber, plastic, stainless steel and brass. This makes this pump corrosion resistant. The TARA Pump is subject to Indian Standard IS 14106.

### Technical data

Cylinder diameter (mm):	54.2
Maximum Stroke (mm):	600
*) Approx. discharge at about 75 watt input m <sup>3</sup> /h:	
at 5 m head	3.5
at 10 m head	1.8
at 15 m head	1.2
Pumping lift (m):	2 – 15
Population served (nos.):	100
Households (nos.):	10
Water consumption (lpcd):	20 – 25
Type of well:	borehole (or dugwell)

### Material

■ Pump head	galvanised steel
■ Handle	galvanised steel
■ Pump rods	PVC pipe
■ Rising main	PVC pipe
■ Cylinder	PVC pipe
■ Plunger/footvalve	different materials

### Local manufacturing

The TARA Pump has an excellent potential for local manufacturing.

### Installation

The installation of the TARA Pump is easy and does not need any lifting equipment or special tools. The drillers who sink the tube well with the "sludger method" also install the pump.

### Maintenance

This pump has an excellent "Community Management Potential". Only simple tools are needed to pull out the entire pumping element and the footvalve. A village caretaker can perform all maintenance operations.

### Remarks

This pump is like most of the "Direct Action Pumps" (DAP) limited to pumping lifts of a maximum of 15 m. It is recommended not to go deeper than 12 m. The TARA Pump is not designed for a high daily output, but rather a family or small community pump.

### Suppliers

The TARA Pump is a public domain handpump. Technical information and a list of recommended manufacturers are available from HTN SKAT, homepage: [www.skat.ch](http://www.skat.ch)

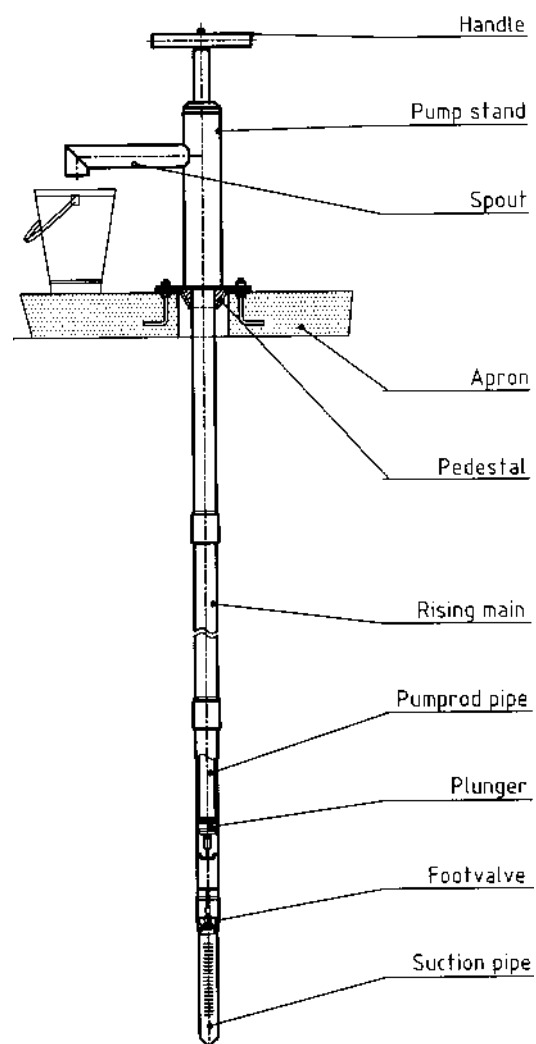

## 9.4 NIRA AF85 Pump

### Description

The NIRA AF85 Direct Action Handpump is based on a buoyant pump rod that is directly articulated by the user, discharging water at the up- and down stroke. The pump head and the standing plate are made of galvanised steel and the handle of stainless steel. Pump rod and rising main are of HDPE pipes and the rest of the down hole components are made of plastics. This makes this pump completely corrosion resistant.

### Technical data

Cylinder diameter (mm):	53.4
Maximum Stroke (mm):	400
*) Approx. discharge at about 75 watt input m <sup>3</sup> /h:	
at 5 m head	3.5
at 10 m head	1.8
at 15 m head	1.2
Pumping lift (m):	2 – 15
Population served (nos.):	300
Households (nos.):	30
Water consumption (lpcd):	15 – 20
Type of well:	borehole or dugwell

### Material

■ Pump head	galvanised steel
■ Handle	stainless steel
■ Pump rods	HDPE pipe
■ Rising main	HDPE pipe
■ Plunger/footvalve	HDPE

### Local manufacturing

The NIRA AF85 Pump is a protected product and is not intended for local production. Although besides the main company in Finland, there is one branch in Ghana (Ghanira) and one in Tanzania (Tanira) producing this pump.

### Installation

The installation of the NIRA AF 85 Pump is easy and does not need any lifting equipment or special tools.

### Maintenance

This pump has an excellent "Community Management Potential". Only simple tools are needed to pull out the entire pumping element as well as the footvalve and rising main. This pump is reliable and popular with the communities.

### Remarks

This pump is like most of the "Direct Action Pumps" (DAP) limited to pumping lifts of a maximum of 15 m. It is recommended not to go deeper than 12 m.

### Suppliers

Technical information on the NIRA AF85 is available from Vammalan Konepaya Inc. P.O. Box 54, SF-38201, Vammala, Finland. Tel: +358 351126 67 / Fax: +358 351 431 34.

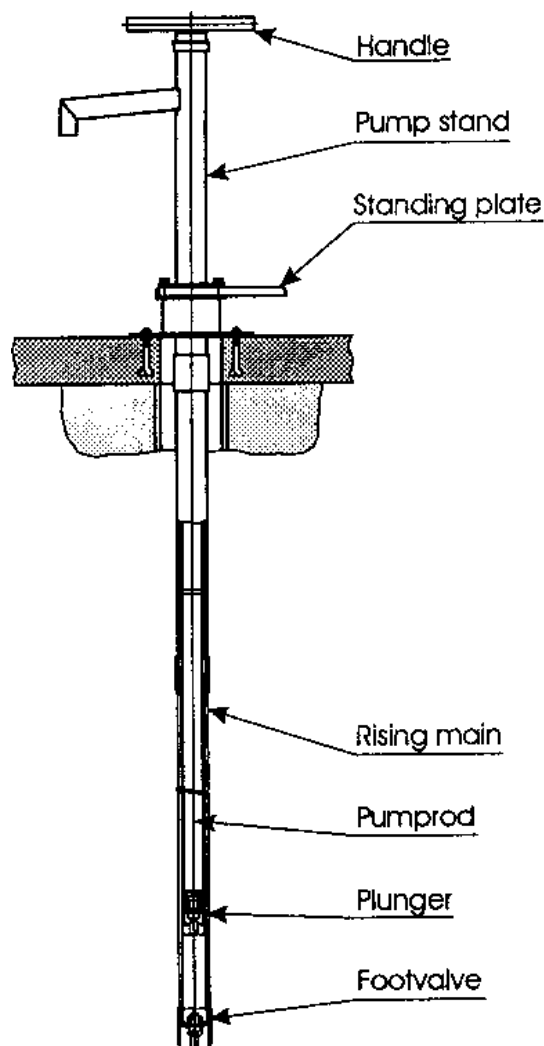

## 9.5 MALDA Pump

### Description

The MALDA Pump as a Direct Action Handpump is based on a buoyant pump rod that is directly articulated by the user, discharging water at the up- and down stroke. The pump head, standing plate and the handle are made of galvanised steel. The sleeve, which protects the handle bar against wear, is made of stainless steel. Pump rod and rising main are of HDPE pipes and the rest of the down hole components are made of plastics. This makes this pump completely corrosion resistant.

### Technical data

Cylinder diameter (mm):	50.0
Maximum Stroke (mm):	410
*) Approx. discharge at about 75 watt input m <sup>3</sup> /h:	
at 5 m head	3.5
at 10 m head	1.8
at 15 m head	1.2
Pumping lift (m):	2 – 15
Population served (nos.):	300
Households (nos.):	30
Water consumption (lpcd):	15 – 20
Type of well:	borehole or dugwell

### Material

■ Pump head	galvanised steel
■ Handle	galvanised steel
■ Handle sleeve	stainless steel
■ Pump rods	HDPE pipe
■ Rising main	HDPE pipe
■ Cylinder	HDPE pipe
■ Plunger/footvalve	HDPE

### Local manufacturing

The MALDA Pump is specially designed to be produced in various developing countries.

### Installation

The installation of the MALDA Pump is very easy and does not need any lifting equipment or special tools. The rising main with footvalve and pump head as well as the pump rod with handle and plunger can be assembled on the ground. When laid next to each other the correct length can be checked. For the installation both, the rising main and the pampered do not need to be dismantled again.

### Maintenance

This pump has an excellent "Community Management Potential". Only simple tools are needed to pull out the entire pumping element as well as the footvalve and rising main.

### Remarks

This pump is like most of the "Direct Action Pumps" (DAP) limited to pumping lifts of a maximum of 15 m. It is recommended not to go deeper than 12 m.

### Suppliers

The MALDA Pump is a public domain handpump. Technical information and a list of recommended manufacturers are available from HTN SKAT, homepage: [www.skat.ch](http://www.skat.ch)

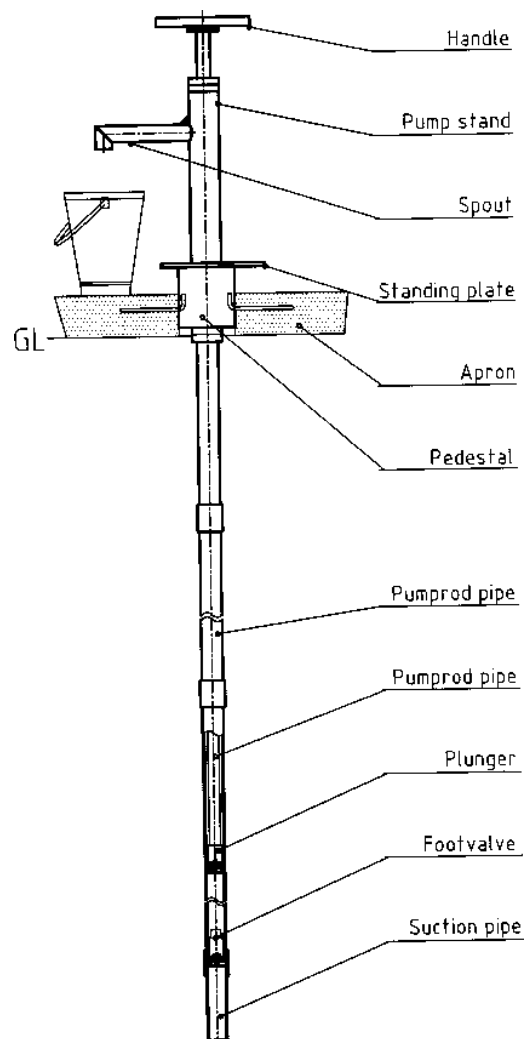

## 9.6 INDIA Mark II Pump

### Description

The INDIA Mark II Pump is a conventional lever action handpump and is subject to Indian Standard IS 9301. This pump has a pump head, pump stand and a handle of galvanised steel. The down hole components exist of a brass lined cast iron cylinder with a footvalve and a plunger of brass. The plunger has a double nitrile rubber cup seal, the rising main is a Ø32 mm GI pipe and the pump rods are of galvanised steel with threaded connectors. This pump is not corrosion resistant and should not be used in areas with aggressive water ( pH value < 6.5 ).

### Technical data

Cylinder diameter (mm):	63.5
Maximum Stroke (mm):	125
*)Approx. discharge at about 75 watt input m <sup>3</sup> /h:	
at 10 m head	1.8
at 15 m head	1.3
at 20 m head	1.0
at 25 m head	0.9
at 30 m head	0.8
Pumping lift (m):	10 – 50
Population served (nos.):	300
Households (nos.):	30
Water consumption (lpcd):	15 – 20
Type of well:	borehole

### Material

■ Pump head	galvanised steel
■ Handle	galvanised steel
■ Pump stand	galvanised steel
■ Pump rods	galvanised steel
■ Rising main	galvanised GI pipe
■ Pump cylinder	cast iron / brass
■ Plunger/footvalve	brass

### Local manufacturing

All "above ground components" have a potential for local manufacturing, all the other parts need a high degree of quality control to ensure a reliable operation. The cost of the tooling requirement is substantial and therefore the number of manufacturer will be limited.

### Installation

The installation of the INDIA Mark II Pump need well trained area mechanics or a mobile team with lifting tackle and comprehensive tool kit.

### Maintenance

This pump has limited "Community Management Potential", but it is reliable and popular with the communities. To service the INDIA Mark II Pump skills and tools are needed which exceeds the ability of a village-level caretaker. However trained area mechanics can successfully maintain the pump.

### Suppliers

The INDIA Mark II is a public domain handpump. Technical information and a list of recommended manufacturers are available from HTN SKAT, homepage: [www.skat.ch](http://www.skat.ch)

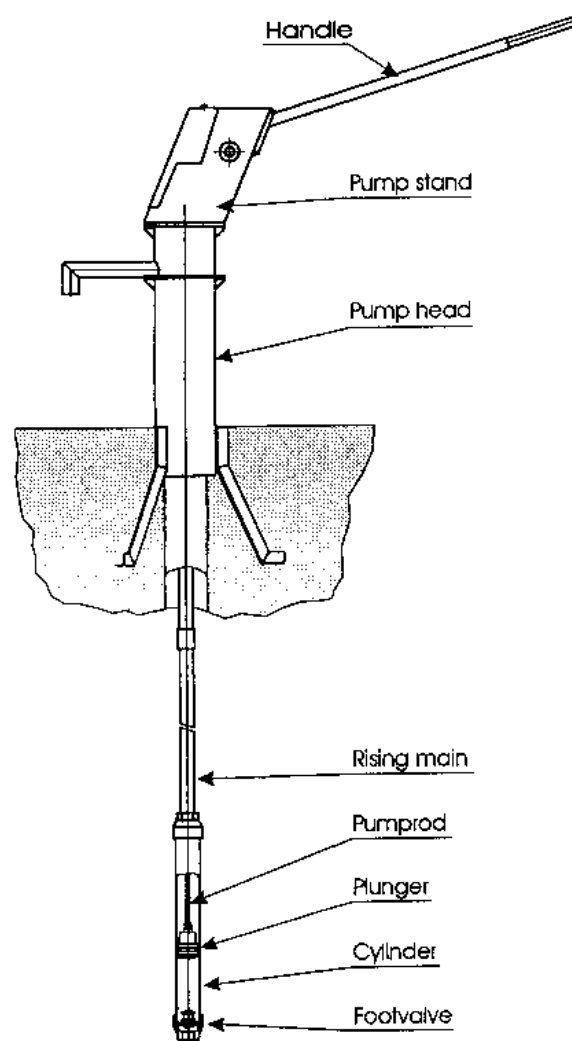

## 9.7 INDIA Mark III Pump

### Description

The INDIA Mark III Pump is a conventional lever action handpump and is subject to Indian Standard IS 13056. This pump has similar configurations as the INDIA Mark II, only the “down hole components” were changed in order to improve the village level maintenance. The most important improvement is the “open top cylinder”, which makes it possible to remove the plunger and also the footvalve without lifting the cylinder and the rising main (Ø65 GI pipe). This pump is not corrosion resistant and should not be used in areas with aggressive water (pH value < 6.5).

### Technical data

Cylinder diameter (mm):	63.5 (50)
Maximum Stroke (mm):	127
*) Approx. discharge at about 75 watt input m <sup>3</sup> /h:	
at 10 m head	1.8
at 15 m head	1.3
at 20 m head	1.0
at 25 m head	0.9
at 30 m head	0.8
Pumping lift (m):	10 – 30
Population served (nos.):	300
Households (nos.):	30
Water consumption (lpcd):	15 – 20
Type of well:	borehole

### Material

■ Pump head	galvanised steel
■ Handle	galvanised steel
■ Pump stand	galvanised steel
■ Pump rods	galvanised steel
■ Riser pipes	galvanised GI pipe
■ Pump cylinder	cast iron / brass
■ Plunger/footvalve	brass

### Local manufacturing

All “above ground components” have a potential for local manufacturing, the other parts need a high degree of quality control to ensure a reliable operation. The cost of the tooling requirement is substantial and therefore the number of manufacturer will be limited.

### Installation

The installation of the INDIA Mark III Pump needs well-trained area mechanics or a mobile team with lifting tackle and comprehensive tool kit. Pump cylinder settings of more than 30 m are difficult, because of weight of the rising main.

### Maintenance

This pump has an improved “Community Management Potential” compared to the INDIA Mark II, because the “open top cylinder” gives the possibility of a simpler maintenance with less tools involved.

### Suppliers

The INDIA Mark III is a public domain handpump. Technical information and a list of recommended manufacturers are available from HTN SKAT, homepage: [www.skat.ch](http://www.skat.ch)

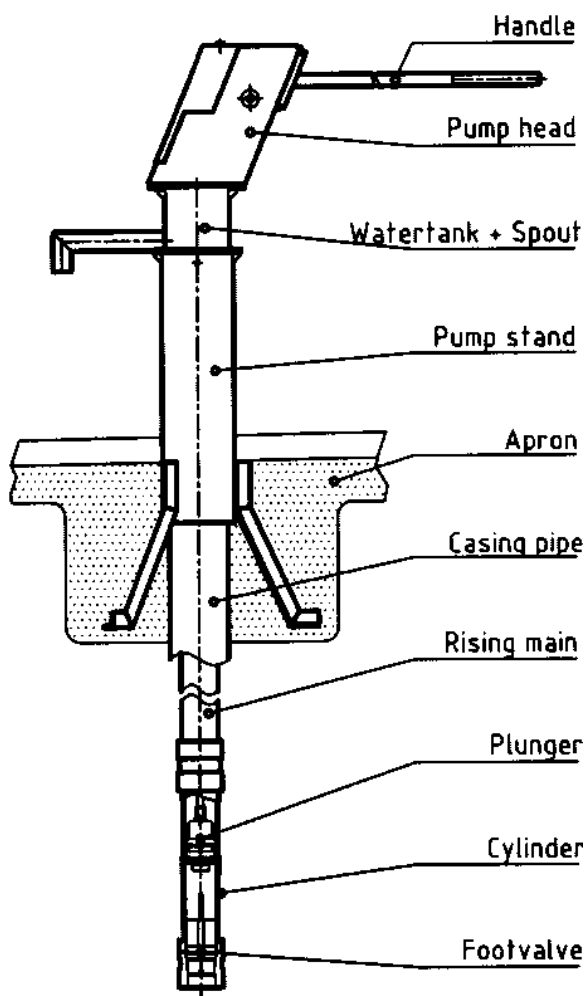

## 9.8 AFRIDEV Pump

### Description

The AFRIDEV Pump is a conventional lever action handpump. The configuration includes an open top cylinder, i.e. the piston can be removed from the cylinder without dismantling the rising main. The footvalve is retractable with a fishing tool. The riser pipes are made of u-PVC. The pump rods are of stainless- or mild steel with hook and eye connectors, allowing removal without tools. Engineering plastics like POM and PA 66 are used for the pumping elements, plunger/footvalve and for the bearings. This pump is corrosion resistant in the stainless steel rod configuration.

### Technical data

Cylinder diameter (mm):	50
Maximum Stroke (mm):	225
*) Approx. discharge at about 75 watt input m <sup>3</sup> /h:	
at 10 m head	1.4
at 15 m head	1.1
at 20 m head	0.9
at 30 m head	0.7
Pumping lift (m):	10 – 45
Population served (nos.):	300
Households (nos.):	30
Water consumption (lpcd):	15 – 20
Type of well:	borehole

### Material

■ Pump head	galvanised steel
■ Handle	galvanised steel
■ Pump stand	galvanised steel
■ Pump rods	SS or galvanised steel
■ Rising main	u-PVC pipe 63 mm
■ Pump cylinder	u-PVC pipe 2 inch
■ Plunger/footvalve	Polyacetal POM

### Local manufacturing

All steel parts of this pump have a potential for local manufacturing.

Local companies who manufacture u-PVC pipes and have the knowledge of processing engineering plastics are able to produce the "down hole components".

The cost of the tooling requirement is substantial and therefore the number of manufacturer will be limited.

### Installation

The installation of the AFRIDEV Pump is not difficult and does not need any lifting equipment.

### Maintenance

This pump has an excellent "Community Management Potential", it is reliable, easy to repair by a village caretaker and popular with the communities. The only tools needed are one spanner and the fishing tool.

### Suppliers

The Afridev is a public domain handpump. Technical information and a list of recommended manufacturers are available from HTN SKAT, homepage: [www.skat.ch](http://www.skat.ch)

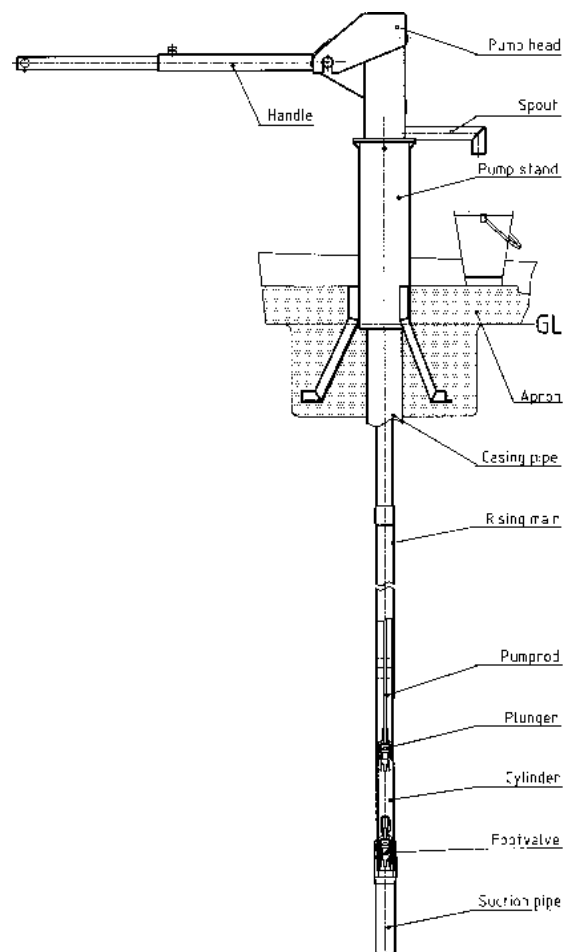



## 9.9 U3M Pump

### Description

The U3M pump is a conventional lever action handpump. The configuration includes an open top cylinder, i.e. the piston can be removed from the cylinder without dismantling the rising main. The footvalve is retractable with a fishing tool. The riser pipes are made of u-PVC. The pump rods are of stainless steel or glass fibre reinforced plastic, allowing simple removal. The pumphead has similar configurations as the INDIA Mark III, the "down hole components" are similar to Afridev components. The cylinder follows the Afridev configuration. The plunger uses the 50 mm open top India MKIII brass design. This pump is fully corrosion resistant.

### Technical data

Cylinder diameter (mm):	50
Maximum Stroke (mm):	150
*) Approx. discharge at about 75 watt input m <sup>3</sup> /h:	
at 10 m head	1.2
at 15 m head	1.0
at 20 m head	0.8
at 30 m head	0.6
Pumping lift (m):	10 – 45
Population served (nos.):	300
Households (nos.):	30
Water consumption (lpcd):	15 – 20
Type of well:	borehole

### Material

■ Pump head	galvanised steel
■ Handle	galvanised steel
■ Pump stand	galvanised steel
■ Pump rods	SS or FRP
■ Rising main	u-PVC pipe 63 mm
■ Pump cylinder	u-PVC pipe with brass liner 50 mm
■ Plunger/footvalve	brass/plastic

### Local manufacturing

All "above ground components" and steel parts of this pump have a potential for local manufacturing. The other parts need a high degree of quality control to ensure a reliable production. Local companies who manufacture u-PVC pipes are able to produce the rising main. The cost of the tooling requirement is substantial and therefore the number of manufacturer will be limited.

### Installation

The installation of the U3M Pump is not difficult and does not need any lifting equipment.

### Maintenance

This pump has an excellent "Community Management Potential", it is reliable, easy to repair by a village caretaker and popular with the communities. Few tools are needed for all repairs.

### Suppliers

The U3M is a public domain handpump. Technical information and a list of recommended manufacturers are available from HTN SKAT, homepage: [www.skat.ch](http://www.skat.ch)

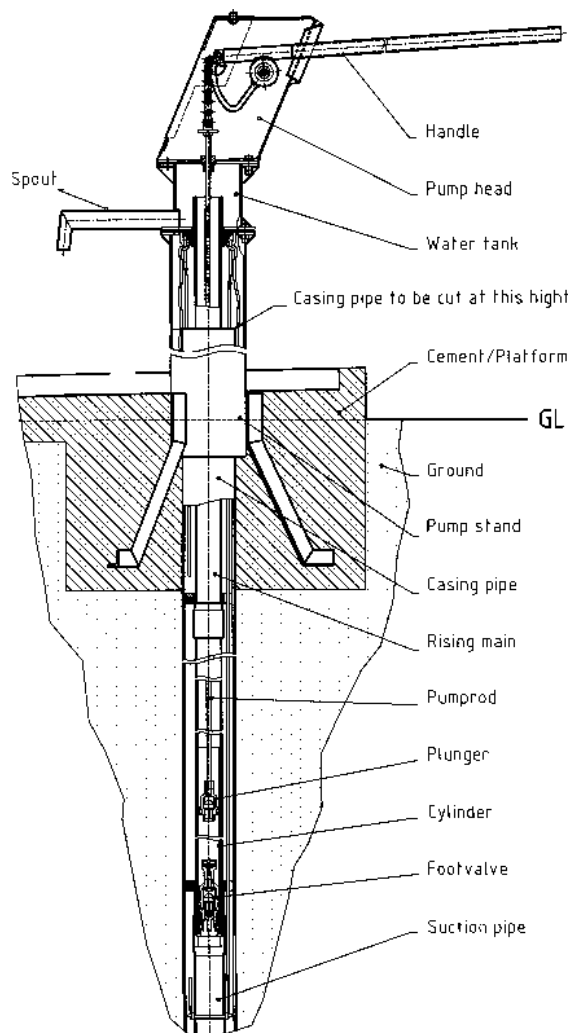

## 9.10 VERGNET Pump

### Description

The VERGNET Pump has unconventional design features. It is operated by foot with a pedal. The displacement of the piston located at ground level is hydraulically transmitted to a rubber diaphragm down in a stainless steel cylinder. The expansion and the contraction of the diaphragm deliver the water to the surface. The top cylinder is connected to the pumping element on the bottom, via a flexible hose. The pumping element is made of rubber and stainless steel, which makes this pump corrosion resistant.

### Technical data

Cylinder diameter (mm):	N/A
Maximum Stroke (mm):	200
*) Approx. discharge at about 75 watt input m <sup>3</sup> /h:	
at 10 m head	1.0
at 15 m head	0.9
at 20 m head	0.75
at 30 m head	0.65
Pumping lift (m):	10 – 45
Population served (nos.):	300
Households (nos.):	30
Water consumption (lpcd):	15 – 20
Type of well:	borehole

### Material

■ Pump stand	galvanised steel
■ Foot pedal	mild steel
■ Pipes (flexible hose)	HDPE
■ Top cylinder	stainless steel
■ Bottom cylinder	stainless steel
■ Pumping element	rubber diaphragm
■ Valves	brass

### Local manufacturing

The VERGNET Pump is a protected product and is not intended for local manufacturing. Only the steel parts of the pump stand would have a potential for local manufacturing.

### Installation

The installation of the VERGNET Pump is very simple and does not need any lifting equipment.

### Maintenance

This pump has a good "Community Management Potential". The above ground components allow interventions by the village caretaker, but below ground components are difficult to repair. The diaphragm requires frequent cleaning.

### Remarks

The replacement of a diaphragm is expensive. The pump requires a considerable effort to operate. Although full body weight can be applied to the pedal, children and small users find it sometimes hard to operate the pump. If the yield of the borehole allows and the water demand is high, it is possible to install 2 pumps in one borehole.

### Suppliers

Technical information on the VERGNET Pump is available from Vergnet S.A. 6, rue Henry Dunant, F- 45140 INGRE, France. Tel: + 33 1 38 43 36 52 / Fax: + 33 1 38 88 30 50

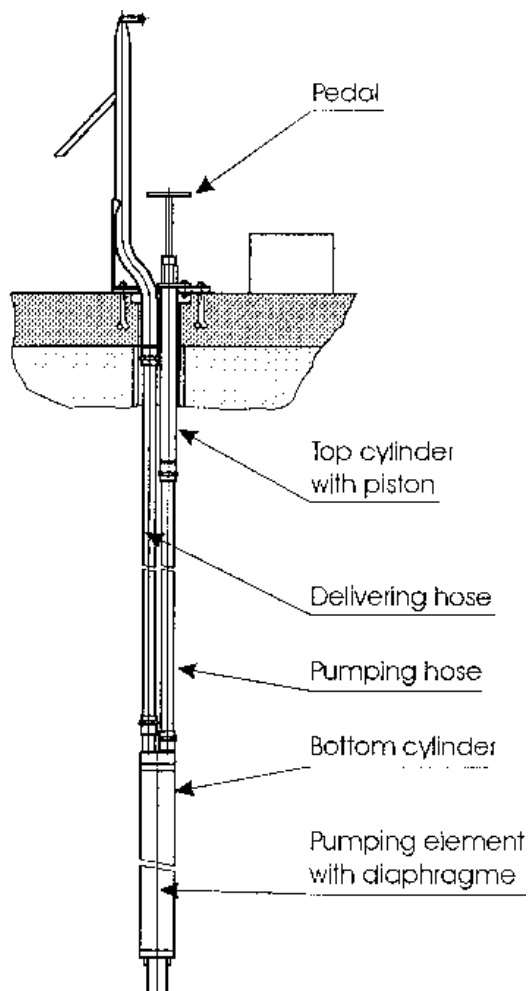

## 9.11 VOLANTA Pump

### Description

The VOLANTA Pump is a reciprocating pump driven by a large flywheel. A crank and a connecting rod convert the rotary motion in a reciprocating action, which is transmitted to the plunger via stainless steel pump rods. The crankshaft and the flywheel run on ball bearings mounted on a plate which can be fixed to a steel or concrete pedestal. The cylinder is of glass fibre reinforced plastic with a close-fitting seal-less stainless steel plunger. The complete cylinder can be lifted from the well by the threaded pump rods, without removing the PVC rising main. This pump is corrosion resistant.

### Technical data

Cylinder diameter (mm):	50
Maximum Stroke (mm):	400
*) Approx. discharge at about 75 watt input m <sup>3</sup> /h:	
at 20 m head	1.0
at 40 m head	0.5
at 60 m head	0.25
(at 80 m head	0.15)
Pumping lift (m):	10 – 80
Population served (nos.):	300
Households (nos.):	30
Water consumption (lpcd):	15 – 20
Type of well:	borehole

### Material

■ Pump stand	mild steel painted
■ Flywheel	mild steel painted
■ Rising main	PVC
■ Pump cylinder	reinforced epoxy resin
■ Plunger / Pump rods	stainless steel
■ Valves	rubber

### Local manufacturing

The VOLANTA Pump is a protected product and is not intended for local manufacturing, but there are countries where assembling and installation of this pump are made locally.

### Installation

The installation of the VOLANTA Pump is not difficult and does not need any lifting equipment. However extensive masonry work is required.

### Maintenance

This pump has an excellent "Community Management Potential". Only simple tools are needed to pull out the entire pumping element, including pump rod and footvalve.

### Remarks

Some users find it difficult to start the pump. Small children have to stay away from this pump, especially the area of the rotating flywheel is a dangerous playground. Because of the PVC rising main, the pump should not be used in unlined boreholes.

### Suppliers

Technical information on the VOLANTA Pump is available from Jensen Venneboer b.v., P.O. Box 12, NL-8130 AA Wijhe, the Netherlands. Tel: + 31 57052 2525 / Fax: + 31 57052 3618.

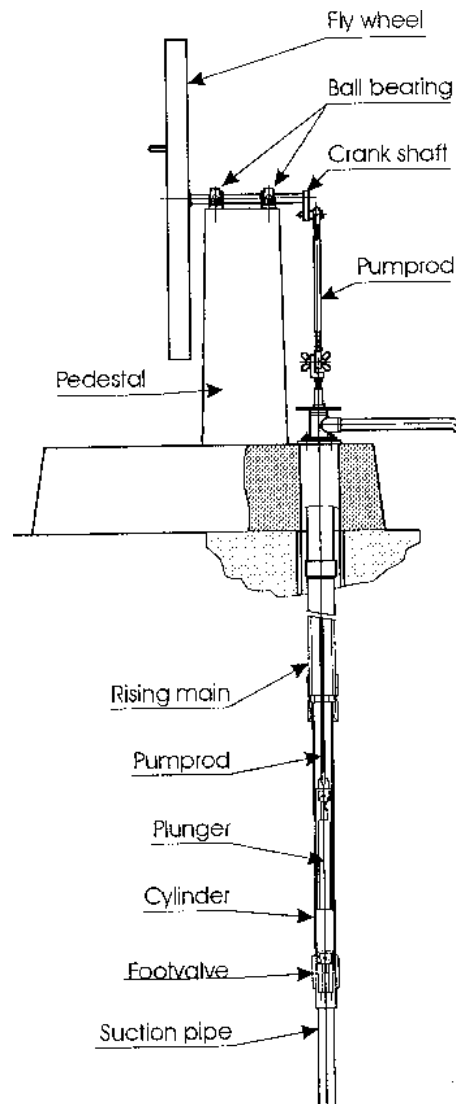

## 9.12 BUSH Pump

### Description

The Bush Pump is a conventional lever action handpump. The typical feature of this pump is the "Hardwood block" that acts as both a bearing and lever mechanism. The pump stand is of painted mild steel and the handle is a galvanised GI pipe. The "down hole components" consist of Ø50 mm (NB) GI pipe for the rising main, pump rods of Ø16 mm galvanised mild steel, brass footvalve and cylinder (Ø75 mm), bronze plunger with leather seals. This pump is not corrosion resistant and should not be used in areas with aggressive water ( pH value < 6.5 ).

### Technical data

Cylinder diameter (mm):	75
Maximum Stroke (mm):	200 – 250
*) Approx. discharge at about 75 watt input m <sup>3</sup> /h:	
at 10 m head	1.4
at 15 m head	1.1
at 25 m head	0.8
at 30 m head	0.7
Pumping lift (m):	5 – 50
Population served (nos.):	300
Households (nos.):	30
Water consumption (lpcd):	15 – 20
Type of well:	borehole or dugwell

### Material

■ Pump stand	painted steel
■ Handle	galvanised steel pipe
■ Bearing block	Hardwood
■ Pump rods	galvanised steel
■ Riser pipes	galvanised GI pipe
■ Pump cylinder	brass
■ Plunger/footvalve	bronze/brass

### Local manufacturing

The Bush Pump has an excellent potential for local manufacturing and is produced by different companies in Zimbabwe.

### Installation

The installation of the Bush Pump needs well trained area mechanics. Lifting tackle is only used for deep applications and for large size "open top cylinders". No special tools are needed.

### Maintenance

The pump with the Standard configuration has a limited Community Management Potential", but it is reliable and popular with the community. The "open top cylinder version" gives the possibility of a simpler maintenance (see remarks).

### Remarks

Besides the "Standard" configuration, there exists an "Open Top Cylinder" version with different cylinder sizes (Ø50 mm/Ø63.5 mm/Ø75 mm). To make maintenance easy, pump rods with casehardened hook and eye connectors are also available.

### Suppliers

Technical information on the Bush Pump is available from The National Action Committee for Water Supplies and Sanitation, Government of Zimbabwe.

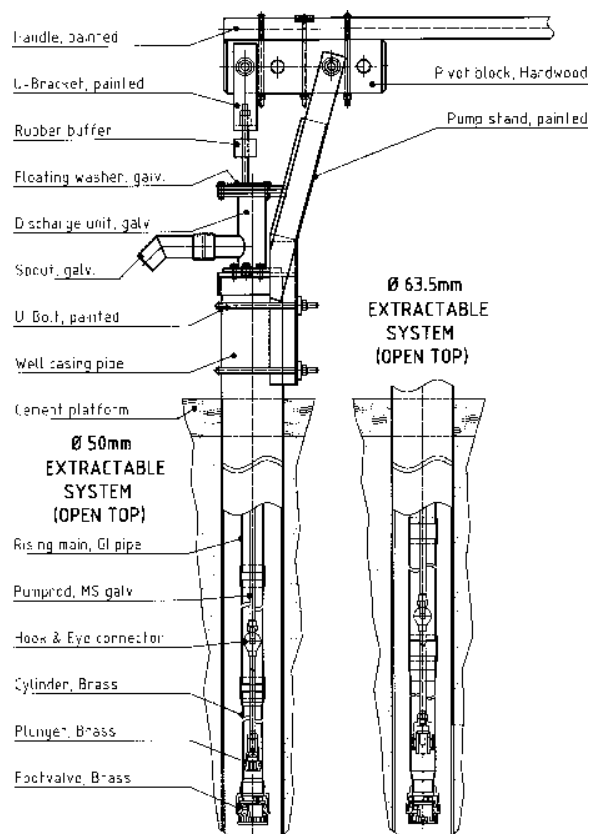

## 9.13 Rope Pump

### Description

The Rope Pump features a unique design in which small plastic pistons are lined up on a rope. The distance between the pistons is approximately 1 m. Over a crank operated drive wheel the rope is pulled through a plastic rising pipe. The pump stand is of painted mild steel and the drive wheel consists of cut old tires. A ceramic guide box leads the rope with the pistons into the rising pipe. This pump is reasonably corrosion resistant.

### Technical data

Piston nominal diameter (inch):	1", ¾", ½"
*) Approx. discharge at about 75 watt input m <sup>3</sup> /h:	
at 10 m head	1.4
at 15 m head	1.1
at 30 m head	0.7
Pumping lift (m):	0 – 30
Population served (nos.):	70
Households (nos.):	3 – 10
Water consumption (lpcd):	15 – 20
Type of well:	dugwell or borehole

### Material

■ Pump stand	painted steel
■ Crank	painted steel pipe
■ Drive pulley	rubber and mild steel
■ Pistons	plastic
■ Guide box	ceramic and PVC
■ Rising pipe	PVC pipe

### Local manufacturing

The Rope Pump has an excellent potential for local manufacturing and is produced by different companies in Nicaragua as well as elsewhere.

### Installation

The installation of the Rope Pump is easy. It can be done by trained area mechanics. No lifting tackle and no special tools are needed.

### Maintenance

The rope pump has an excellent "Community Management Potential". A torn or broken rope can be replaced without any special tools. A village caretaker can perform all maintenance operations.

### Remarks

This rope pump is usually installed in dug wells. Even though it is not limited in pumping lifts, the major application range is up to 15 m. The Rope pump is not designed for a high daily output, but rather a family or small community pump. Models exist for family use as well as for community use.

### Suppliers

The rope pump is a public domain handpump. Technical information and a list of recommended manufacturers is available from Rope Pump Technology Transfer Division, Apartado postal 3352, Managua, Nicaragua, e-mail sdc-agua@ibw.com.ni

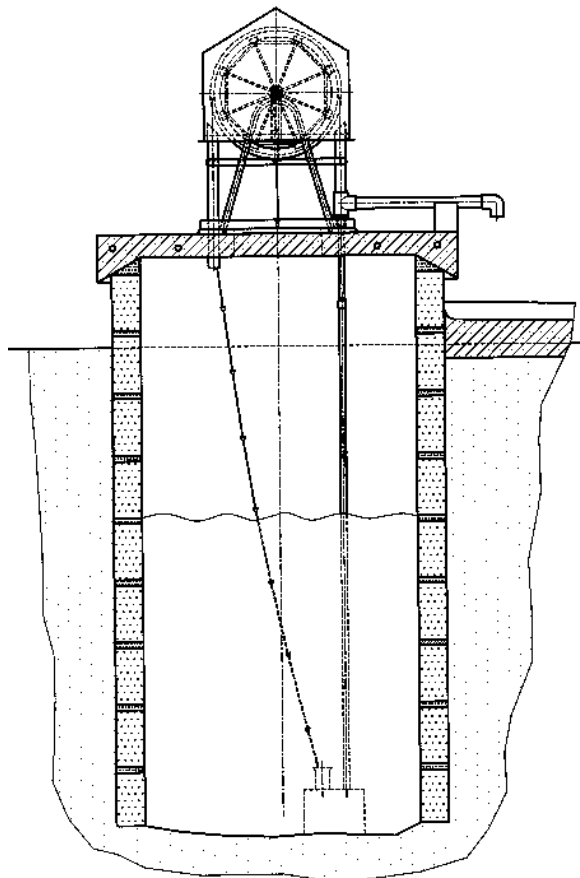

# SERIES OF MANUALS ON DRINKING WATER SUPPLY

<b>VOLUME</b>	<b>1</b>	<b>Management Guide</b>
<b>VOLUME</b>	<b>2</b>	<b>Engineering</b>
<b>VOLUME</b>	<b>3</b>	<b>Building Construction</b>
<b>VOLUME</b>	<b>4</b>	<b>Spring Catchment</b>
<b>VOLUME</b>	<b>5</b>	<b>Hand-dug Shallow Wells</b>
<b>VOLUME</b>	<b>6</b>	<b>Drilled Wells</b>
<b>VOLUME</b>	<b>7</b>	<b>Water Lifting</b>

## What you should know about this series of manuals:

<b>It is a guide for</b>	project managers, engineers and technicians but is also useful for all other actors in the sector
<b>with a focus on</b>	community based managed systems (predominantly in rural areas) water supply technologies
<b>with an emphasis on</b>	a balanced strategy including technical, social, institutional, economic and regulatory aspects for the achievement of sustainability
<b>providing options for</b>	management strategies and approaches
<b>providing linkages to</b>	sanitation and health
<b>limited to</b>	experience in Swiss-supported projects, taking account of new developments
<b>does not cover</b>	sanitation drainage solid waste management
<b>Volumes 2 to 7</b>	should be used in conjunction with Volume 1

ISBN

3-908001-99-4