



# **WATER TREATMENT MANUALS**

## **COAGULATION, FLOCCULATION & CLARIFICATION**

**ENVIRONMENTAL PROTECTION AGENCY**  
An Ghníomhaireacht um Chaomhnú Comhshaoil  
PO Box 3000, Johnstown Castle Estate, Co. Wexford, Ireland.  
Telephone: +353-53-60600 Fax: +353-53-60699  
Email: [info@epa.ie](mailto:info@epa.ie) Website: [www.epa.ie](http://www.epa.ie)

© Environmental Protection Agency 2002

Although every effort has been made to ensure the accuracy of the material contained in this publication, complete accuracy cannot be guaranteed. Neither the Environmental Protection Agency nor the author(s) accept any responsibility whatsoever for loss or damage occasioned or claimed to have been occasioned, in part or in full, as a consequence of any person acting, or refraining from acting, as a result of a matter contained in this publication. All or part of this publication may be reproduced without further permission, provided the source is acknowledged.

## **WATER TREATMENT MANUALS**

### **COAGULATION, FLOCCULATION & CLARIFICATION**

Published by the Environmental Protection Agency, Ireland.

Printed on recycled paper

The Agency personnel involved in the production and preparation of this manual were Mr. Noel Bourke, Mr. Gerry Carty, Mr. Gerard O'Leary, Dr. Matt Crowe and Mr. Darragh Page.

# TABLE OF CONTENTS

<b>TABLE OF CONTENTS</b>	<b>3</b>
<b>LIST OF FIGURES</b>	<b>6</b>
<b>LIST OF TABLES</b>	<b>6</b>
<b>PREFACE</b>	<b>7</b>
<b>ACKNOWLEDGEMENTS</b>	<b>9</b>
<b>LIST OF ABBREVIATIONS</b>	<b>10</b>
<b>1. INTRODUCTION</b>	<b>11</b>
1.1 Introduction to Coagulation, Flocculation and Clarification	11
1.2. Influence of Raw Water Source and Quality on Treatment	11
1.3 Influence of End Use of Water on Treatment	13
1.4 Nature of Impurities in Water	13
1.5 Need for Coagulation and Flocculation	13
<b>2. CHEMICALS USED IN COAGULATION/FLOCCULATION</b>	<b>14</b>
2.1 Coagulant Chemicals	14
2.2 Alkaline Chemicals and Acids	14
2.3 Coagulant Aids and Polyelectrolytes	14
2.4 Delivery, Storing and Feeding Chemicals	15
2.5 Chemical Reactions	16
2.6 Mixing	17
<b>3. COAGULATION</b>	<b>19</b>
3.1 Process Description	19
3.2 Basic Coagulant Chemistry	19
3.3 Optimising Coagulation	19
3. 4 Process Performance Considerations	23
<b>4 FLOCCULATION</b>	<b>26</b>
4.1 Process Description	26

4.2 Floc Formation	26
4.3 Process Performance Considerations	26
<b>5. CLARIFICATION</b>	<b>29</b>
5.1 Process Description	29
5.2 Theory of Sedimentation	29
5.3 Clarification by Settlement	29
5.4 Flotation	32
5.5 Interaction with Coagulation and Flocculation	32
5.6 Modification to Treatment Process	33
5.7 Pilot Plant Testing of Modifications	33
<b>6. PROCESS CONTROL</b>	<b>34</b>
6.1 Operating Procedures Associated with Normal Process Conditions	34
6.2 Operating Procedures Associated with Abnormal Process Conditions	39
6.3 Laboratory Tests	42
6.4 Startup and Shutdown Procedures	43
<b>7. RECORD KEEPING</b>	<b>46</b>
7.1 Importance of Recordkeeping	46
7.2 Chemical Stores Records	46
7.3 Jar Test Records	46
7.4 Records of Modifications Made to Treatment	46
<b>8. OPERATION AND MAINTENANCE</b>	<b>48</b>
8.1 Types of Equipment	48
8.2 Equipment Operation	48
8.3 Preventive Maintenance Procedures	48
8.4 Safety Considerations	49
<b>9. MANAGEMENT AND CONTROL</b>	<b>52</b>
9.1 Management system and audit scheme	52
9.2 Initial Environmental Review	52
9.3 Environmental Policy and Objectives	54
9.4 Organisation and Personnel	54

9.5 Environmental Effects Register	54
9.6 Operational Control	54
9.7 Documentation and Records	54
9.8 The Audit	54
9.9 Sector Reports	54
9.10 Annual Report	54
<b>GLOSSARY</b>	<b>55</b>
<b>APPENDIX A: CHEMICALS USED IN COAGULATION / FLOCCULATION / CLARIFICATION</b>	<b>59</b>
<b>APPENDIX B: TYPICAL OPERATING RECORD SHEET FOR A SMALL TREATMENT WORKS</b>	<b>63</b>
<b>APPENDIX C: JAR TEST DETAILS</b>	<b>67</b>
<b>APPENDIX D: BATCH SOLUTION / SUSPENSION PREPARATION CURVES</b>	<b>73</b>
<b>APPENDIX E: ADJUSTMENT AND CALIBRATION OF CHEMICAL FEEDERS</b>	<b>81</b>
<b>REFERENCES &amp; READING LIST</b>	<b>83</b>

## LIST OF FIGURES

<i>Figure 1: Typical Water Treatment Processes</i>	12
<i>Figure 2: Apparatus for Conducting Jar Tests</i>	20
<i>Figure 3: Typical Coagulation Curve</i>	21
<i>Figure 4: Typical pH Optimisation Curve - hard lowland water</i>	22
<i>Figure 5: Typical pH Optimisation Curve - soft coloured water</i>	22
<i>Figure 6: Variation of pH With Time in a Raw Water Reservoir Containing Algae</i>	23
<i>Figure 7: Methods of Flash Mixing</i>	25
<i>Figure 8: Horizontal Flocculator and Horizontal Flow Sedimentation Tank</i>	27
<i>Figure 9: Hopper Bottomed Upflow Sludge Blanket Settlement Tank</i>	28
<i>Figure 10: Flat-Bottomed Upflow Sludge Blanket Settlement Tank</i>	28
<i>Figure 11: Solids Contact Clarifier</i>	31
<i>Figure 12: Dissolved Air Flotation Unit</i>	33
<i>Figure 13: Coagulation-Flocculation-Clarification Process</i>	35
<i>Figure 14: Dosing Pump Calibration</i>	49
<i>Figure 15: Management and audit schematic</i>	53
<i>Figure 16: Comparator for the Evaluation of Floc Size Index in Coagulation Tests</i>	70
<i>Figure 17: Batch Solution Preparation Curve for Aluminium Sulphate</i>	78
<i>Figure 18: Batch Solution Preparation Curves for Ferric Salts</i>	78
<i>Figure 19: Batch Solution Preparation Curves for Sodium Carbonate</i>	79
<i>Figure 20: Dosing Calibration Pump</i>	82

## LIST OF TABLES

<i>Table 1: Summary of Routine Coagulation-Flocculation-Clarification Process Actions</i>	40
<i>Table 2: Coagulation-Flocculation-Clarification Process Troubleshooting</i>	41
<i>Table 3: Potential Hazards in Coagulation-Flocculation-Clarification</i>	50
<i>Table 4: Stock Solutions for Coagulation Tests</i>	68

## PREFACE

The Environmental Protection Agency was established in 1993 to license, regulate and control activities for the purposes of environmental protection. In the Environmental Protection Agency Act, 1992, it is stated that “the Agency may, and shall if so directed by the Minister, specify and publish criteria and procedures, which in the opinion of the Agency are reasonable and desirable for the purposes of environmental protection”. These criteria and procedures in respect of water treatment are being published by the Agency in a number of manuals under the general heading of Water Treatment Manuals.

This manual on *Coagulation, Flocculation & Clarification* sets out the general principles and practices which should be followed by those involved in the production of drinking water. It follows on from the manual on *Filtration* published in 1996 and will be followed by manuals on *Disinfection*. Where criteria and procedures are published by the Agency, a sanitary authority shall, in the performance of its functions, have regard to such criteria and procedures.

This manual includes information on many aspects of Coagulation, Flocculation & Clarification. The Agency hopes that it will provide practical guidance to those involved in plant operation, use, management, maintenance and supervision. The Agency welcomes any suggestions which users of the manual may wish to make. These should be returned to the Environmental Management and Planning Division at the Agency headquarters on the attached User Comment Form.





## ACKNOWLEDGEMENTS

The Agency wishes to acknowledge those who contributed to and reviewed this manual. A review panel was established by the Agency to assist in the finalisation of the manual and it acknowledges below those persons who took the time to offer valuable information, advice and in many cases comments and constructive criticism on the draft manual. The Agency gratefully acknowledges the assistance offered by the following persons:

John Anderson, Department of the Environment and Local Government

Martin Beirne, Environmental Health Officers Association

Owen Boyle, Department of the Environment and Local Government

Aideen Burke, Jones Environmental (Ireland) Ltd

Tom Casey, Aquavarra Research Ltd.

Aidan Delaney, North Tipperary County Council

Ronnie Dunne, Department of the Environment and Local Government

Jonathan Evans, Department of the Environment and Local Government

Ned Fleming, Dublin Corporation

Louis Kilmartin, Department of the Environment and Local Government

Tom Loftus, Dublin Corporation

David McBratney, M.C. O'Sullivan & Co. Ltd

Colum McGaughey, Dublin Corporation

Peter O'Connor, University College, Dublin

John O'Flynn, Waterford County Council (representing the County and City Engs' Association)

Kevin Power, M.C. O'Sullivan & Co. Ltd

Paul Ridge, Galway County Council

John Walsh, E.G. Pettit & Company Ltd

The Agency also wishes to acknowledge the assistance of the Sanitary Services sub-committee of the Regional Laboratory, Kilkenny, who commented on the draft manual and to Mr. Finabar O' Mahoney, Health and Safety Authority who commented on appendix A.

## LIST OF ABBREVIATIONS

APHA	American Public Health Association
DAF	Dissolved Air Flootation
d	Day
G	Gram
GRP:	Glass Reinforced Plastic
HDP:	High Density Polythene
MAC:	Maximum Allowable Concentration
kg	Kilogram
l	Litre
m	Metre
mg	Milligram
mm	Millimetre
µg:	Microgram
nm:	Nanometer
NOM:	Natural Organic Matter
NTU:	Nephelometric Turbidity Units
PAC	Polyaluminium chloride
°C	degrees Celsius
PAH:	Polynuclear Aromatic Hydrocarbons
PVC:	Polyvinylchloride
uPVC:	Unplasticised PVC
USEPA:	United States Environmental Protection Agency
UV:	Ultraviolet
v/v:	ml/100ml
w/w:	g/100g
WHO:	World Health Organisation

## 1. INTRODUCTION

Absolutely pure water is rarely, if ever, found in nature. The impurities occur in three progressively finer states - suspended, colloidal and dissolved matter. Different methods of treatment are required for their removal or reduction to acceptable limits.

Coagulation, Flocculation and Clarification, shown in Figure 1, as well as Filtration are interdependent stages of the solids separation phase of water treatment.

In the production of drinking water, coagulation and flocculation are almost universally used before filtration, except where water is treated by slow sand filtration. Clarification, which may be by settlement or flotation, is the unit step used immediately before filtration, unless direct filtration is used in cases where the source water is low in turbidity, colour, plankton and coliform organisms.

Failure or inadequacy in any of the stages will have adverse effects on the subsequent stages and may result in the production of water with excessive turbidity and other undesirable qualities. Thus, chemical dosing which is not optimal means that the conditions for coagulation are not the optimum; the floc formed may be unsuitable for the method of clarification in use, is not removed efficiently and passes on to the filters where it may break through to appear as turbidity in the final water or seriously reduce the length of filter run.

### 1.1 INTRODUCTION TO COAGULATION, FLOCCULATION AND CLARIFICATION

The single most important factor influencing the effectiveness of water treatment, particularly coagulation, flocculation and clarification is probably the consistency of the raw water supply. The quality of the raw water supply is not normally amenable to human control and this can give rise to major problems in coagulation when quality varies in an irregular fashion, as described later. Consistency in quantity or rate of supply is normally readily controllable and is a fundamental requirement for the proper operation of sedimentation systems. This becomes increasingly important for floc blanket systems treating thin coloured waters where even very slight disturbances in the rate of flow can lead to disruption of the floc blanket, which is then swept

over to impose an extra load on the filtration stage, often resulting in poor filtered water quality.

The divisions between Coagulation, Flocculation and Clarification are not rigid. A large number of plants in this country include hopper bottomed tanks formed as inverted pyramids with tank sides sloped at about 60° to the vertical. Water, which has been treated with coagulants, is discharged downwards near the bottom centre of the tank and turns through 180°, giving conditions suitable for flocculation. As the water flows upwards, its velocity decreases as the cross sectional area of the tank increases. The bottom portion of the tank is effectively a zone of coagulation and flocculation. As the water rises further up in the tank, clarification takes place so that coagulation, flocculation and clarification occur in the one tank.

### 1.2. INFLUENCE OF RAW WATER SOURCE AND QUALITY ON TREATMENT

The raw water source has a considerable effect on the choice of water treatment. Groundwater sources are likely to yield water free from biological contamination by colour, plankton or coliform organisms but which may have a high dissolved solids content. The dissolved solids may include iron and / or manganese in excess of permitted concentrations for drinking water. Treatment in this case must be designed to precipitate and separate the metals.

Surface water from an upland lake or reservoir that may otherwise be of good quality, may have a high colour due to drainage from peat bogs and be acidic with poor buffering capacity. Such waters need the addition of alkali to provide suitable conditions for coagulation and flocculation to remove the colour. A lowland lake or reservoir may have hard water but be subject to algal blooms, which cause changes in the chemical balance of the water due to the transpiration of the algae. These changes make optimum chemical conditioning very difficult to achieve on a continuous basis. Algae in the water may influence the choice of method of clarification, as the algal debris may be more suited to removal by flotation than by settling. Upland rivers are likely to be flashy, with soft,

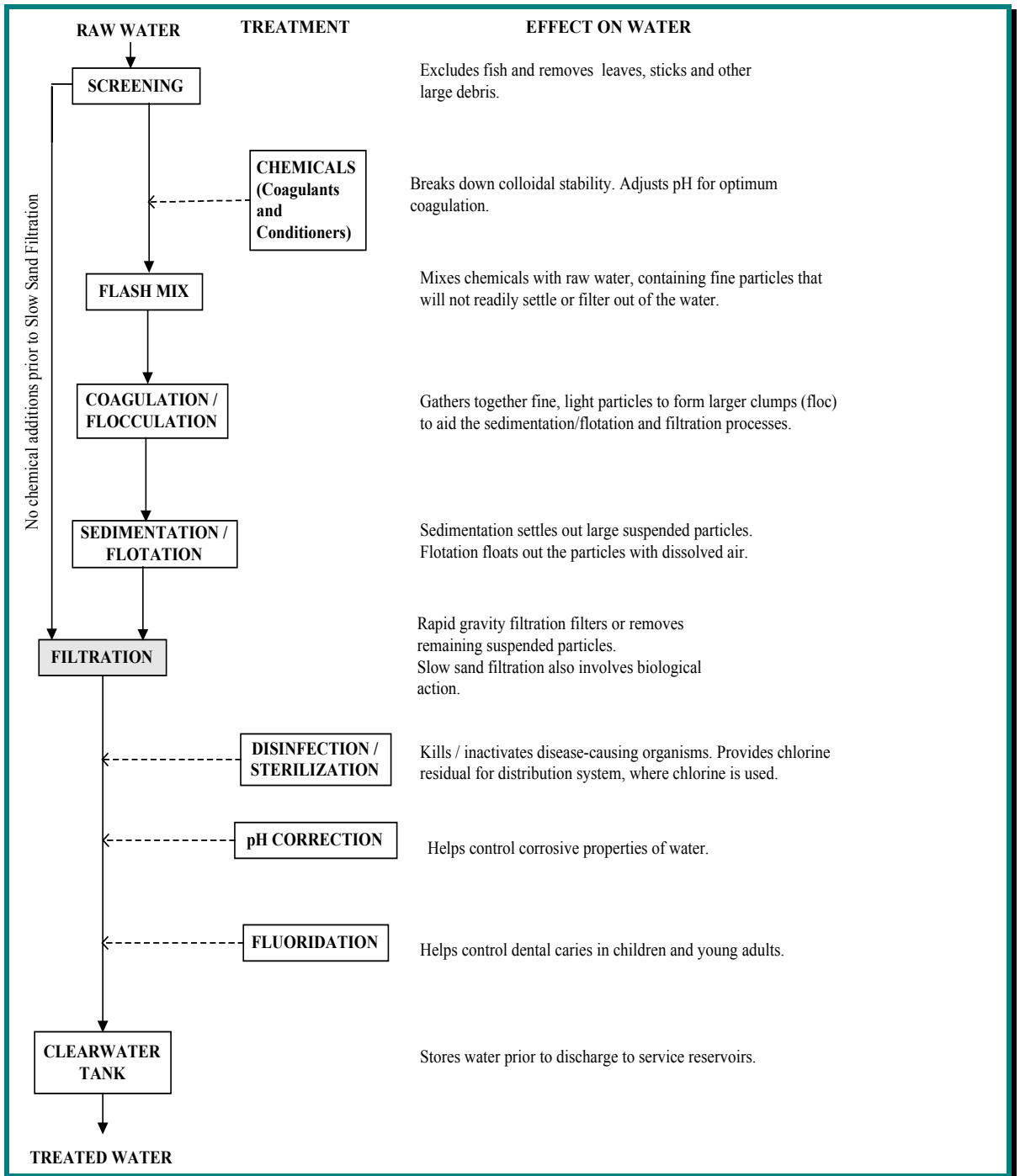

FIGURE 1: TYPICAL WATER TREATMENT PROCESSES

poorly buffered water while lowland river water is likely to be hard and carry more organic matter.

### 1.3 INFLUENCE OF END USE OF WATER ON TREATMENT

Controls on the quality of drinking water in Ireland are defined in the European Communities (Quality of Water Intended for Human Consumption) Regulations, 1988 and in the European Communities (Quality of Surface Water Intended for the Abstraction of Drinking Water) Regulations, 1989. To a large extent, these Regulations dictate the level of treatment required prior to distribution. End-users other than domestic consumers may impose further restrictions and requirements which can affect the level of treatment needed. The reader is reminded that on 1 January 2004 the 1988 Regulations referred to above will be revoked and the European Communities (Drinking Water) Regulations 2000 (S.I. 439 of 2000) come into operation.

Hospitals and clinics for instance, where kidney dialysis is carried on, may have problems with aluminium sulphate treated water as may some industrial users. It may be desirable or necessary in such cases to change to the use of iron based coagulants or of polyelectrolyte as the primary coagulant in some cases. Changes to coagulants, coagulant aids or dose rates are dealt with in Section 5.6.

### 1.4 NATURE OF IMPURITIES IN WATER

Particulate and dissolved impurities in water result from land erosion, pickup of minerals, the decay of plant material with additional impurities from airborne contamination, sewage and industrial discharges, and from animal wastes. Thus, surface water sources, polluted by man and nature, are likely to contain suspended and dissolved organic (plant or animal origin) and inorganic (mineral) material, and biological forms such as bacteria, spores, cysts and plankton.

The particulate impurities (commonly called suspended solids) cover a broad size range. Larger sized particles such as sand and heavy silts can be removed from water by slowing down the velocity of flow to allow for simple gravity settling. These particles are often called settleable solids. Settling of intermediate sized particles occurs naturally when surface water is stored for a sufficient period in a reservoir or a lake. The availability or provision of even a few days raw water storage can be an important preliminary

treatment step. Such storage ensures a substantial reduction in suspended solids and bacteria levels, evens out fluctuations in raw water quality as well as providing some protection against toxic ingress and provides a strategic storage reserve. Smaller sized particles, such as spores, cysts, plankton, fine clays and silts with their associated bacteria, do not readily settle and treatment is required to produce larger particles that are more amenable to removal. These smaller particles are often called nonsettleable solids or colloidal matter.

### 1.5 NEED FOR COAGULATION AND FLOCCULATION

The purpose of coagulation and flocculation is to condition impurities, especially non-settleable solids and colour, for removal from the water being treated. Coagulating chemicals cause non-settleable particles to clump together to form floc. In the coagulation process, chemicals are added which will initially cause the colloidal particles to become destabilised and clump together.

The particles gather together to form larger particles in the flocculation process (see Figure 1). When pieces of floc clump together, they may form larger, heavier flocs which settle out and are removed as sludge. In other cases flocs are removed from the water by flotation.

With few exceptions, surface waters require treatment to remove particulate impurities and colour before their distribution to the consumer in order to comply with the quality standards prescribed by law.

## 2. CHEMICALS USED IN COAGULATION/FLOCCULATION

Chemicals used in coagulation / flocculation are referred to either as primary coagulants or as coagulant aids. Primary coagulants are used to cause the particles to become destabilised and begin to clump together. The purpose of coagulant aids may be to condition the water for the primary coagulant being used, to add density to slow-settling flocs or toughness so the floc will not break up in the following processes.

### 2.1 COAGULANT CHEMICALS

Salts of aluminium or iron are the most commonly used coagulant chemicals in water treatment because they are effective, relatively low cost, available, and easy to handle, store, and apply. Aluminium sulphate - commonly called alum or sulphate of alumina - is still very widely used although concern about the possible adverse effects of dissolved aluminium has recently been expressed in some quarters. Other aluminium salts used are PAC (polyaluminium chloride), which may have some advantages over aluminium sulphate particularly in the coagulation of 'difficult' waters, polyaluminium chlorosulphate and polyaluminium silicate sulphate.

Solutions of ferric sulphate and chloride are aggressive, corrosive acidic liquids, the chloride more so than the sulphate. They behave as coagulants in a corresponding fashion to aluminium sulphate but form ferric hydroxide floc in the presence of bicarbonate alkalinity. Water treatment using iron coagulants requires close process control because excessive residual iron will result in consumer complaints of staining of clothing during washing, particularly where automatic machines are used. A similar excess aluminium residual causes less noticeable effects.

Ferrous sulphate - also termed copperas, iron sulphate or sugar of iron - is probably the cheapest of all salts that can be used for coagulation. It has formerly been widely used in drinking water treatment, in conjunction with chlorine as chlorinated copperas. The likelihood of the formation of trihalomethanes (THM), by the action of the excess chlorine required to complete the chlorination reaction, has caused the use of this coagulant to be largely or entirely discontinued in the public water supply sphere.

Natural organic polyelectrolytes such as sodium alginates and some soluble starch products have long been used in water treatment. Newer synthetic polyelectrolytes are now widely available. Proprietary coagulants consisting of solutions of synthetic polyelectrolytes and metal salts are also on the market.

### 2.2 ALKALINE CHEMICALS AND ACIDS

In soft waters, where the natural alkalinity is insufficient to react with the coagulants, alkalinity must be added either as lime or soda-ash. The alkalinity serves to neutralize the sulphuric acid which forms, together with hydroxide, when sulphates hydrolyse. If left in the water the acid would recombine with the hydroxide and revert to sulphate. Hydroxide is the desired end product as it is insoluble, floc-forming and heavier than water, and it carries the positive electric charge necessary to neutralize the negative charges of the colloidal particles. Alkaline chemicals are added also, if required, to provide the optimum pH value for coagulation to take place.

In very alkaline waters, the addition of the optimum dose, for colour and turbidity removal, of a metallic salt such as alum or ferric sulphate, may not depress the pH to the optimum level for coagulation. Increasing the dose of metallic salt will further depress the pH but will result in a very undesirable increase in the soluble metallic content of the water, which will carry through the filters to supply. Dosing with a strong mineral acid, such as sulphuric acid, will depress the pH without the unwelcome increase in the soluble metallic content of the water.

### 2.3 COAGULANT AIDS AND POLYELECTROLYTES

Coagulant aids are used to improve the settling characteristics of floc produced by aluminium or iron coagulants. The coagulant aid most used for a number of years was activated silica, prepared from sodium silicate 'activated' by various chemicals including chlorine and sulphuric acid. It can still give the best results, mainly when used with aluminium sulphate, but a high level of technical expertise is required for its successful use.

Sodium aluminate is a compound of sodium oxide and aluminium oxide. It is a white powder and is

almost invariably used as a coagulant aid in conjunction with alum. It is mainly useful in alkaline waters, reacting with the natural alkalinity to give insoluble and flocculant calcium aluminate; clarification is better, the floc is denser and coagulation is effective even at low temperatures over a wide pH range.

Other aids used were sodium alginates and some soluble starch products. These substances had the advantage of being well known materials already used in connection with foodstuffs, and were thus recognised as harmless in the treatment of water. Various forms of clay such as bentonite or fuller's earth have occasionally been used as an aid to coagulation with aluminium sulphate, when treating water low in turbidity but with high alkalinity.

Polyelectrolytes were originally of natural origin such as starches and alginates. They now include numerous synthetic products: long-chain organic molecules with chemical groups attached along the length of the chain which become charged when the molecule is dissolved in water. These groups can be cationic (+ charge), anionic (- charge), non-ionic (zero charge) or amphoteric (+ and - charges). Polyelectrolytes are used to flocculate particulate matter; that is to bring together small particles into larger agglomerates and may be used as flocculant aids alongside aluminium or iron coagulants to improve their effectiveness.

Polyelectrolytes may also be used in special cases as primary coagulants to replace, totally or partially, inorganic coagulants. Amongst other effects they reduce the mass of sludge for disposal. The main mechanism by which they function is charge neutralisation, as with the metallic salts. Because suspended material in fresh waters is normally negatively charged, only cationic (positively charged) products are used in such applications. The charge density and molecular weights of polyelectrolytes are of greater interest for coagulation than their chemical formulas, which are usually trade secrets. The user is therefore advised to refer to safety data sheets for information on the material.

Although polyelectrolytes themselves are not toxic, some of the monomers from which they are made, notably acrylamide, are. The monomer is soluble in water and is not adsorbed by solids, so that in the solid/liquid separation which follows flocculation, any residual monomer remains in the water. A small part remains, of course, in the water content of the sludge.

The use of polyelectrolytes in the treatment of drinking water is subject to scrutiny. The 2000

Drinking Water Regulations (S.I. 439 of 2000) impose a limit of 0.1 µg/l for acrylamide. This concentration is below the limit of detection of convenient methods of analysis. Thus regulating the concentration of acrylamide in water is achieved by specifying the maximum concentration of monomer permissible in polyacrylamide and the amount of the polymer that may be used as a flocculant.

The need for the addition of polyelectrolytes, during periods when water temperatures are above 12° C, should be examined. Above this temperature, coagulants work more effectively and at some plants it may be possible to reduce or omit polyelectrolytes during the period from April to early October, if the raw water quality is of a reasonable standard. In this case the flow rates adopted in the clarification stage should be conservative if problems with floc carryover and consequently with filtration are to be avoided.

The application of polyelectrolytes, on a regular basis, in plants which have not been specifically designed to use them is inadvisable. Polyelectrolytes have been used to ensure the water produced is of acceptable quality, while pushing production to the limit. This procedure usually degrades the filters in a short time, although the problem appears to be less severe in plants which have a combined upwash/air scour installed for the filters. The output rating of any older plants, which have to use polyelectrolytes on a continuous basis to meet quality standards, should be reviewed and reduced if necessary.

## 2.4 DELIVERY, STORING AND FEEDING CHEMICALS

Details of some of the chemicals used in Coagulation are given in Appendix A. References to some safety measures applicable for their handling are noted as are the materials, which are suitable for the containment, preparation and delivery of the chemicals.

Maintaining the appropriate level of chemical stocks, by ordering the right quantity, is important as some products deteriorate if kept too long. Powdered polyelectrolytes can normally be stored for 12 months and in many cases longer. These products should be stored in a dry atmosphere. Undiluted liquid polyelectrolyte solutions and emulsions will usually have a shelf life of between 4 and 12 months if protected from frost. Blocks of aluminium sulphate will keep almost indefinitely. The maximum economy is achieved when stocks are kept at their lowest practicable safe level.

The appropriate level of chemical stocks will depend on the circumstances of the plant - for instance if truck access to a plant is liable to be impeded at certain seasons stocks must be available to cover this period. Care must be exercised in ordering chemicals to ensure that the correct form, strength and container size as well as quantity are specified and that enough time is allowed to avoid stocks running out before replacements are delivered.

The greatest risk of accident in relation to chemicals is during delivery. Serious damage has been caused by the discharge of a bulk delivery of chemicals into a wrong storage vessel, due to inadequate monitoring of the operation. The possibility of spillages during bulk delivery arises or the chemicals themselves may be wrong, whether bulk or other delivery is involved. The following checks should be made, before any transfer of chemicals begins:

- Is the delivery expected at all?
- Is the chemical in the form that was ordered? (solid or liquid ?)
- Is its strength correct?
- Is the delivery drivers paperwork in order?

In the case of bulk deliveries the following additional checks are required:

- Is there sufficient space in the storage vessel?
- Are all pipes and hoses properly and securely connected and all valves correctly set?
- Is emergency equipment readily available and are emergency procedures in place?

It may be necessary to take a sample and check the strength using a hydrometer or other on-site testing procedure before being satisfied that transfer can begin. The transfer operation should be continuously monitored and never left unattended. When completed, storage vessel valves should closed, before hoses are removed, and then securely locked. All paperwork should be checked against quantities transferred and both delivery driver and plant operator should sign the delivery docket.

The methods of handling and storing chemicals are very much dependant on the size of the treatment works. Large treatment works are normally equipped to accept bulk deliveries of chemicals, while in the smaller works chemicals are delivered in bags or drums. The bulk

handling equipment ensures that chemicals are used in rotation, but bags and drums should be marked with the date of receipt and must be stored so that strict stock rotation will be the easiest means of withdrawing chemicals. Adequate and safe means of moving bags and drums must be provided.

Coagulants are normally added to water, in step with the flow, as solutions, but may be in powder or slurry form. Where solutions are made up by hand a weighing machine should be provided for batching. It should be capable of weighing the normal chemical charge for a batch to the nearest 0.01% of the batch weight e.g., if the normal charge weight is 5 to 10 kg, the machine should weigh up to 10 kg to the nearest gramme. Suitable containers with lids should be provided for carrying the weighed batch to the dissolving tank.

Normally, liquid dosing (either in solution or slurry form) is by means of a pump from a tank, equipped with a stirring mechanism and holding one day's supply of the chemical at the correct strength. Where suspensions or slurries are being dosed, continuous agitation of the preparation tank is essential. Pump and tank are duplicated to permit the preparation of the next day's chemical supply and ensure continuous dosing. The output of the pump must be capable of ready adjustment to suit changes in the dose rate. Gravity-feed dosing has been used, with the dose rate controlled by alteration of the size of orifice in a constant head tank. Dry feeders incorporate a hopper for the chemical powder which is fed to a gravimetric measuring device.

## 2.5 CHEMICAL REACTIONS

The basic requirement for a coagulant chemical, whether a metallic salt or an organic polymer, is to discharge the generally negative charges on colloids present in the water and give rise to a precipitate. When metallic salts such as aluminium sulphate  $\{Al_2(SO_4)_3 \cdot 18H_2O\}$  or ferric sulphate  $\{Fe_2(SO_4)_3 \cdot 9H_2O\}$  are added to water, a series of reactions occur with the water and with other ions in the water. Sufficient quantities of the chemicals must be added to the water to exceed the solubility limit of the metal hydroxide and result in the formation of a precipitate (floc). The resulting floc formed will then adsorb on particles (turbidity) in the water.

*Aluminium Sulphate* is supplied in the solid form as blocks, as granulated or kibbled alum and also in liquid form. The chemical formula of pure aluminium sulphate is  $Al_2 (SO_4)_3 \cdot 18 H_2O$  but



filter alum as commercially supplied may have only 14 H<sub>2</sub>O. The solid form is readily soluble but the solution is corrosive to aluminium, steel and concrete so tanks of these materials need protective linings. The formation of an aluminium hydroxide floc is the result of the reaction between the acidic coagulant and the natural alkalinity of the water, which usually consists of calcium bicarbonate, as expressed by the equation below, with the insoluble products (precipitates) in *italics*:

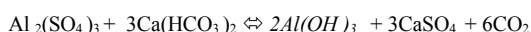

If a water has insufficient alkalinity or 'buffering' capacity, additional alkali such as hydrated lime, sodium hydroxide (caustic soda) or sodium carbonate (soda ash) must be provided for the reaction as expressed by the equation:

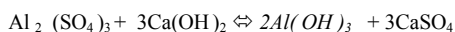

With soda ash added:



A dose of 1 mg/l of aluminium sulphate reacts with 5.3 mg/l of alkalinity expressed as CaCO<sub>3</sub>. Thus if no alkali is added the alkalinity will be reduced by this amount with a consequent reduction in pH. The aluminium hydroxide floc is insoluble over relatively narrow bands of pH, which may vary with the source of the raw water. Therefore pH control is important in coagulation, not only in the removal of turbidity and colour but also to maintain satisfactory minimum levels of dissolved residual aluminium in the clarified water. The optimum pH for the coagulation of lowland surface waters is usually within the range 6.5 to 7.5, whereas for more highly coloured upland waters a lower pH range, typically 5.5 to 6.5 is necessary. Lowland waters usually contain higher concentrations of dissolved salts, including alkalinity, and may therefore require the addition of acid in excess of that provided by the coagulant. The optimum coagulation pH value should be attained by adding sulphuric or similar strong acid rather than excess coagulant.

**Ferric Sulphate** is supplied as a red-brown powder or as granules. Its chemical formula is Fe<sub>2</sub>(SO<sub>4</sub>)<sub>3</sub>·9H<sub>2</sub>O. It is mildly hygroscopic but is difficult to dissolve and the solution is corrosive to aluminium, concrete and most steels. In a manner corresponding to the reaction of aluminium sulphate, the formation of a ferric hydroxide floc is the result of the reaction between the acidic coagulant and the natural

alkalinity of the water, which usually consists of calcium bicarbonate, as expressed by the equation below, with the insoluble products (precipitates) in *italics* :-

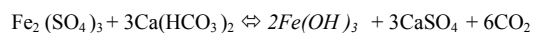

The reactions with added alkali are analogous to those of aluminium sulphate.

**Ferric Chloride** is supplied in the anhydrous form as a green-black powder, chemical formula FeCl<sub>3</sub>, and also as a dark-brown syrupy liquid or as crystal ferric chloride FeCl<sub>3</sub>·6H<sub>2</sub>O. The solid forms are hygroscopic and unsuitable for dry feed. The solution is very corrosive and attacks almost all metals and concrete. In coagulation the reaction is, with the insoluble products (precipitates) in *italics*:

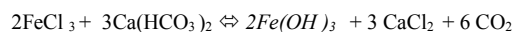

The production of calcium chloride ions in the above reaction may increase the corrosivity of the water and ferric sulphate, despite its higher price, is usually preferred to ferric chloride. The use of chlorinated ferrous sulphate has been dealt with in Section 2.1.

**Polyelectrolytes** also function by charge neutralisation, as with the metallic salts as noted in Section 2.3. Suspended material in fresh waters is normally negatively charged so only cationic (positively charged) products are used.

## 2.6 MIXING

Methods of mixing coagulants with the water flow and type of mixers are dealt with in Section 3.4.

When using sodium aluminate in conjunction with aluminium sulphate the two reagents must never be mixed before addition to the water. The sodium aluminate must be added to the water a short time (0.5 to 2 min.) before the alum.

Polyelectrolyte solutions are extremely viscous and often only very small doses are required. It is therefore essential that there is sufficient turbulence at the dosing point to ensure rapid and thorough mixing of the small amount of reagent with the main water flow. Dilute polyelectrolyte solutions are easier to disperse into the flow than concentrated solutions, but a balance must be struck otherwise the volume of polyelectrolyte solution added will become a significant proportion of the flow.

When used as coagulant aids polyelectrolytes should be dosed after the inorganic coagulant. Sufficient delay time (from one to several minutes) should be allowed following the addition of the inorganic coagulant to allow 'microflocs' to form before dosing the polyelectrolyte. In addition to turbulence at the point of injection, it is also important to allow sufficient delay time following polyelectrolyte addition to permit mixing and/or reaction before the subsequent solids-liquid separation. Delay times of approximately one minute are generally satisfactory, but the required time will depend on the hydrodynamic conditions obtaining on the plant.

Timing of the addition of conditioning chemicals and coagulants, as well as of coagulant aids, has been found to be of great importance and is usually critical to effective clarification performance, satisfactory filter performance, as a consequence, and hence the quality of the final water. Suitable separation of the dosing points for the different chemicals and provision of suitable delay times between chemical additions can be of considerable importance in achieving optimum coagulation. A study by the Water Research Centre of the clarification of five different water types by flotation showed that dosing the coagulant chemicals directly into the raw water feed pipe gave improved quality in the flotation treated water, compared to dosing them into the flash mixer. The order of chemical addition had little influence on the treated water quality - either equal or slightly better results were obtained dosing the pH adjustment chemical first. At one plant, where the distance along the feed pipe separating the points of addition of chemicals could be varied, the quality of water deteriorated if the separation was less than 2 m.

## 3. COAGULATION

The term coagulation describes the effect produced when certain chemicals are added to raw water containing slowly settling or nonsettleable particles. The chemicals hydrolyse and neutralise the electrical charges on the colloidal particles, which begin to form agglomerations termed floc which will be removed by clarification and filtration.

### 3.1 PROCESS DESCRIPTION

The mixing of the coagulant chemical and the raw water to be treated, suitably conditioned if necessary, is commonly referred to as flash mixing. The primary purpose of the flash mix process is to rapidly mix and equally distribute the coagulant chemical throughout the water. The entire process occurs in a very short time (several seconds), and the first results are the formation of very small particles of floc, often referred to as 'microflocs'.

### 3.2 BASIC COAGULANT CHEMISTRY

The theory of coagulation is very complex but the following is a very much simplified outline. Coagulation is a set of physical and chemical reactions, occurring between the alkalinity of the water, the impurities in it and the coagulant(s) added to the water, which results in the formation of insoluble flocs. These are agglomerations of the particulate suspended matter in the raw water, the reaction products of the added chemicals, as well as colloidal and dissolved matter from the water adsorbed by these reaction products.

For a specific coagulant (such as aluminium sulphate), the pH determines which hydrolysis species (chemical compounds) predominate. Lower pH values tend to favour positively charged species, which are desirable for reacting with negatively charged colloids and particulates, forming insoluble flocs and removing impurities from the water.

The optimum pH for alum coagulation, which is very dependant on the water being treated, usually falls in the range of pH 5 to 8, approximately. The aluminium hydroxide floc is insoluble over relatively narrow bands of pH, which may vary with the source of the raw water. Therefore pH control is important in coagulation, not only in the removal of turbidity and colour but also to

achieve the minimum level of dissolved residual aluminium in the clarified water. Residual alkalinity in the water serves to buffer the system (prevent pH from changing) and aids in the complete precipitation of the coagulant chemicals. The amount of alkalinity in the source (raw) water is generally not a problem unless the alkalinity is very low. Alkalinity may be increased by the addition of lime, caustic soda or soda ash.

Polyelectrolytes are used to improve the settling characteristics of floc produced by aluminium or iron coagulants. A study of five waters by the Water Research Centre showed that there was no benefit in dosing polyelectrolytes when flotation was used. Polyelectrolytes may be used as primary flocculants, in exceptional circumstances.

Generally no control is possible over the pH and alkalinity of the water at source. Hence, evaluation of these water quality indicators may play a major role in selecting the type of chemical coagulants to be used at a particular water treatment plant, or in changing the type of coagulant normally used if significant changes in pH and alkalinity occur in the raw water.

Overdosing, as well as underdosing, of coagulants may lead to reduced solids removal efficiency. Either condition may be corrected by carefully performing jar tests and verifying process performance after making any change in the operation of the coagulation process. Similar action may be needed if a change in the quality of the source water is noted.

### 3.3 OPTIMISING COAGULATION

The objective of coagulation is to condition, by chemical addition, the impurities in the water so that they will coalesce in flocculation and be removed in clarification and filtration together with the added chemicals. If the water to be treated were as constant in quality and character as groundwater from a deep well, it would theoretically be possible to calculate from analyses of the water the optimum chemical conditions and dose of coagulant required. Surface water is never as constant in quality and character as groundwater; even in a large lake, temperature changes with the season, particulate matter is blown in by wind which may also cause turbidity to increase due to disturbance of sediment. The optimum chemical conditions in

terms of coagulant dose and pH for treatment of the water concerned are assessed by means of the jar test also called the laboratory coagulation test or the sedimentation jar test.

### 3.3.1 JAR TESTS

The jar test is probably the most important routine test carried out at a water works employing coagulation and flocculation as part of the treatment process. The results should be interpreted with care and used for control of the treatment plant, but not necessarily for prediction of plant operating rates, final turbidity and total (as distinct from soluble) coagulant levels. Numerous variations of jar test procedure are possible. Many try to a procedure that approximates to conditions on the plant; others use conditions that are merely convenient in terms of time. The guiding principle is to choose a procedure that is suitable and not to depart from it unless it is absolutely necessary. If this principle is not adhered to it will be impossible to relate the results of jar tests made at different times.

Jar tests as detailed in Appendix B, employing apparatus similar to that shown in Figure 2, may be used to study the effects of dose of coagulant chemicals and pH, on settled water quality. A single set of tests will normally be sufficient for routine control where there has not been a significant change in conditions. The pH of the sample is adjusted if necessary to that in use in the plant and the current coagulant dose rate is added to one jar with doses slightly above and below in the jars on either side and the test is run

as described. The results should confirm that the current coagulant dose rate is the optimum. It is important, in interpreting the results of jar tests, to remember that, in addition to scale effects, jar mixing is horizontal while in upflow settling tanks mixing occurs vertically, which assists the formation of an equilibrium or stable floc blanket. Therefore optimum coagulation in jars may not always be reproduced in plant performance. The principal value in jar tests lies in predicting trends rather than in predicting exact coagulant concentrations for use in the plant. That is why it is essential in jar tests to choose a procedure that is suitable and not to depart from it unless it is absolutely necessary, as noted above.

A series of three coagulation tests is needed to determine the optimum coagulant dose and pH where a new source is to be used or a very significant change in the existing source has occurred such as an algal bloom in a lake source or a flood in a river source. Initially, no pH adjustment is applied to the raw water and the coagulant dose is varied over a suitable range. A coagulation curve is plotted (Figure 3 ) from which the coagulant demand can be determined.

Quantities of acid or alkali, predetermined by titration, are added to raw water samples to vary the pH, in increments of about 0.5 pH, over a range usually between pH 5.5 and 8.5. The coagulation test is repeated using the dose, determined above as the coagulant demand, in all samples. A plot of final colour and turbidity against pH is used to select the optimum coagulation pH (Figures 4 and 5).

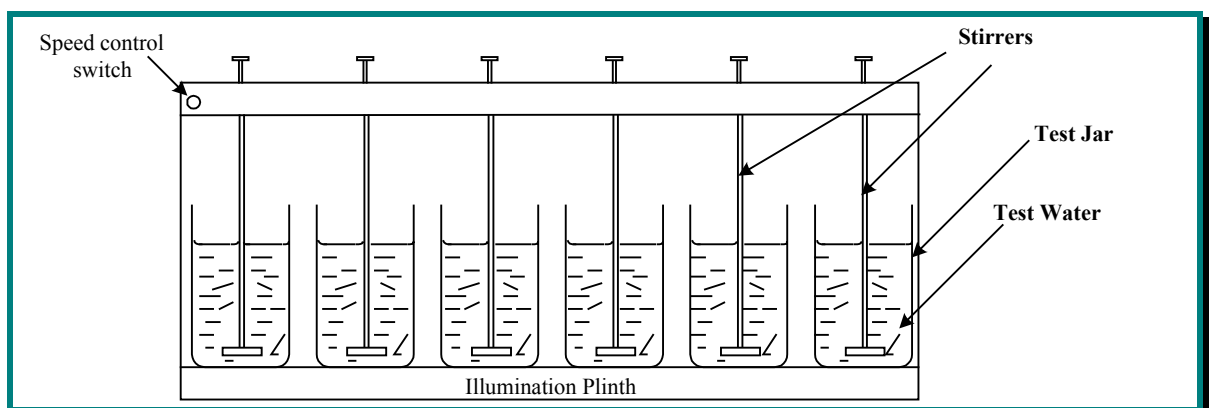

FIGURE 2: APPARATUS FOR CONDUCTING JAR TESTS

The third coagulation test, in which the coagulant dose is varied and the pH is maintained constant at the optimum determined above, is used to determine the optimum dose at the optimum pH. A slightly modified procedure is employed if coagulant aid is to be used.

Optimisation of coagulant dose and coagulation pH in this procedure are based on colour and turbidity removal. The use of results obtained in this way for control of water treatment may sometimes present difficulties. The raw water quality affects the shape of the optimum pH curve. The curves shown in Figure 4 are for a typical fairly hard lowland water. Comparison with Figure 5 for a soft coloured water show that for such a water a much narrower band of coagulation pH has to be maintained and that frequently the optimum colour and turbidity removal do not produce such low minimum

values. A much weaker floc is generally produced in this type of water, which implies lower operating rates in the subsequent treatment stage if sedimentation is employed. Problems arise where colour and /or turbidity levels can fluctuate rapidly, particularly in the case of a soft coloured water. Problems have also been experienced where raw water conditions vary cyclically throughout the day in a way that can affect coagulation e.g. pH variations in waters containing algae (Figure 6 ). Daily measurements taken at the same time each day do not show up these variations. The maintenance of optimum coagulation conditions under such a regime, even with continuous manning of the plant, presents a very big challenge. It is possible, over time and based on the results of jar tests, to develop an empirical dose equation, using readily measured parameters of water quality, to adjust the coagulant dose to cater for such conditions.

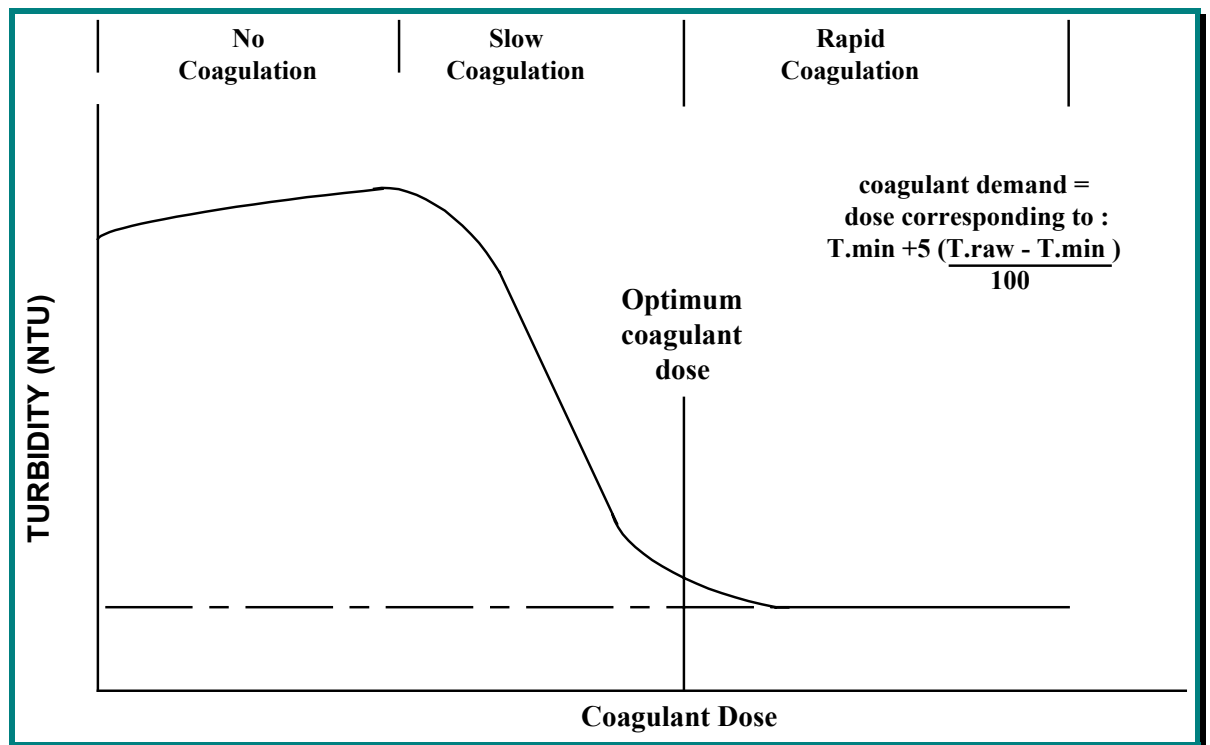

FIGURE 3: TYPICAL COAGULATION CURVE

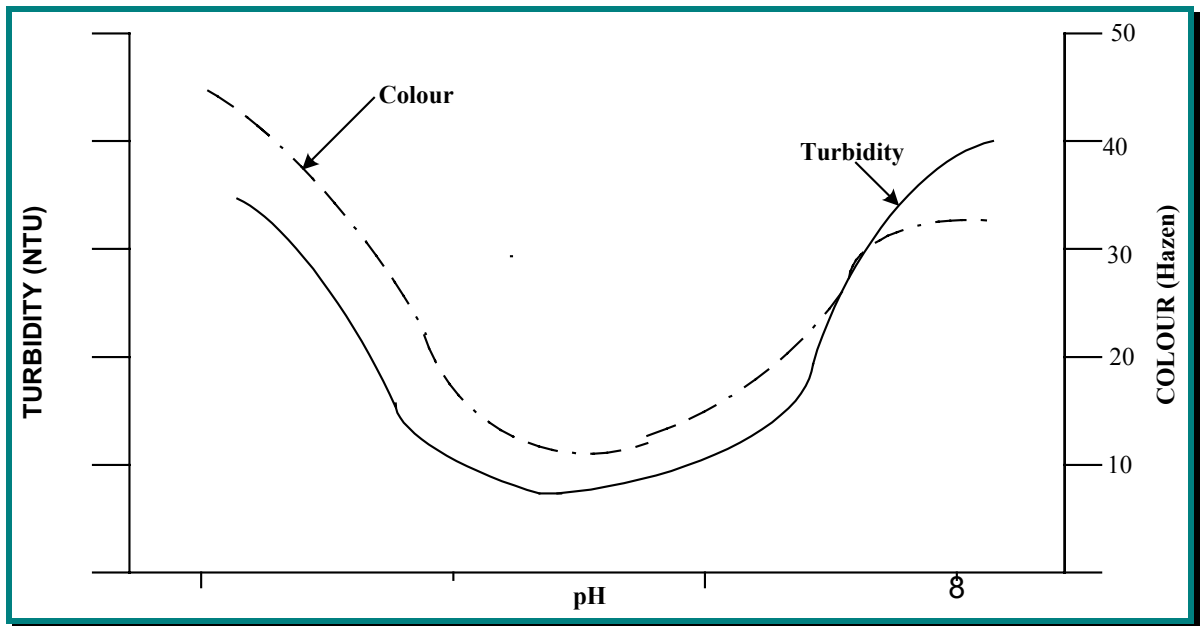

FIGURE 4: TYPICAL pH OPTIMISATION CURVE - HARD LOWLAND WATER

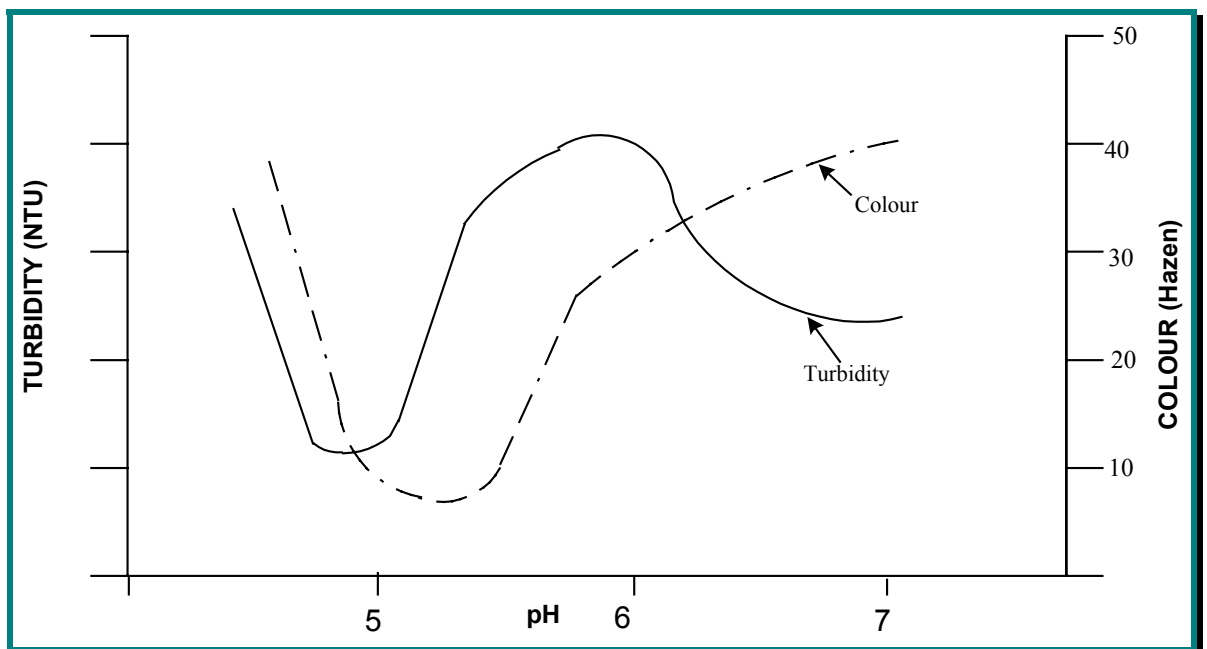

FIGURE 5: TYPICAL pH OPTIMISATION CURVE - SOFT COLOURED WATER

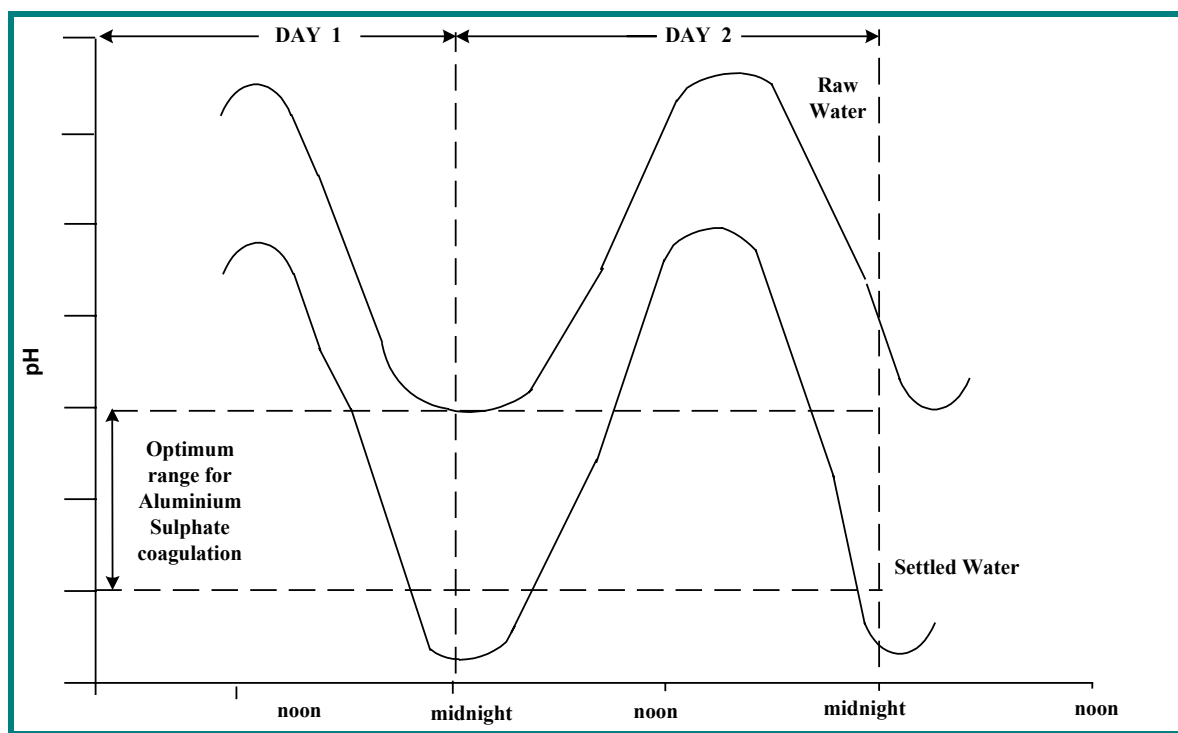

FIGURE 6: VARIATION OF pH WITH TIME IN A RAW WATER RESERVOIR CONTAINING ALGAE

### 3.4 PROCESS PERFORMANCE CONSIDERATIONS

As noted previously timing of the addition of conditioning chemicals and coagulants, as well as of coagulant aids, has been found to be of great importance and is usually critical to clarification performance, filter performance and hence, the quality of the final water.

#### 3.4.1 METHODS OF MIXING

It is desirable to introduce the coagulants at points of high turbulence in the water in order to complete the coagulation reaction (mixing of chemicals into the water) in as short a time as possible - preferably within a period of several seconds since the reaction time is short. The coagulant must make contact with all of the suspended particles in order for complete coagulation and flocculation to take place. This is accomplished by “flash mixing”.

#### 3.4.2 TYPES OF MIXERS

The methods by which mixing can be satisfactorily achieved include (see Figure 7):

1. Hydraulic mixing using flow energy in the system;

2. Mechanical mixing;
3. Diffusers and grid systems; and
4. Pumped blenders.

Hydraulic mixing with baffles or throttling valves works well in systems which have sufficient water velocity (speed) to cause turbulence in the water being treated. The turbulence in the flowing water ensures rapid mixing of the chemicals throughout the total water flow being treated. Hydraulic mixing may not work satisfactorily if the rate of flow through the system is reduced.

Mechanical mixers (paddles, turbines, and propellers) are frequently used in coagulation facilities. Mechanical mixers are versatile and reliable; however, they generally consume the greatest amount of electrical energy for mixing the coagulant with the water being treated.

Diffusers and grid systems consisting of perforated tubes or nozzles can be used to disperse the coagulant into the water being treated. These systems can provide uniform (equal) distribution of the coagulant over the entire coagulation basin. However, they are generally sensitive to flow changes and may require frequent adjustments to produce the proper amount of mixing.

Pumped blenders add the coagulant directly to the water being treated through a diffuser in a pipe. This system can provide rapid dispersion of the coagulant and does not create any significant head loss in the system. Electrical energy consumption is considerably less than that of a comparable mechanical mixer.

### 3.4.3 COAGULATION BASINS

Detention time is not usually a critical factor in the coagulation or flash-mixing process, if the chemical coagulants are satisfactorily dispersed into the water being treated and are mixed for at least several seconds. Detention time is required for the necessary chemical reactions to take place. Some plants have been able to reduce coagulant dosages by increasing the detention time between the point of addition of the coagulant and the flocculation basins.

Mixing of the chemical coagulants may be satisfactorily accomplished in a special tank with mixing devices. The shape of the basin is part of the flash-mix system design. Mixing may also occur in the influent channel or in a pipeline to the flocculation basin if the flow velocity is high enough to produce the necessary turbulence. As noted previously, many of the treatment systems in this country include hopper bottomed tanks, formed as inverted pyramids with tank sides sloped at  $60^\circ$  to the vertical. The lowest sections of these tanks act as coagulation zones.



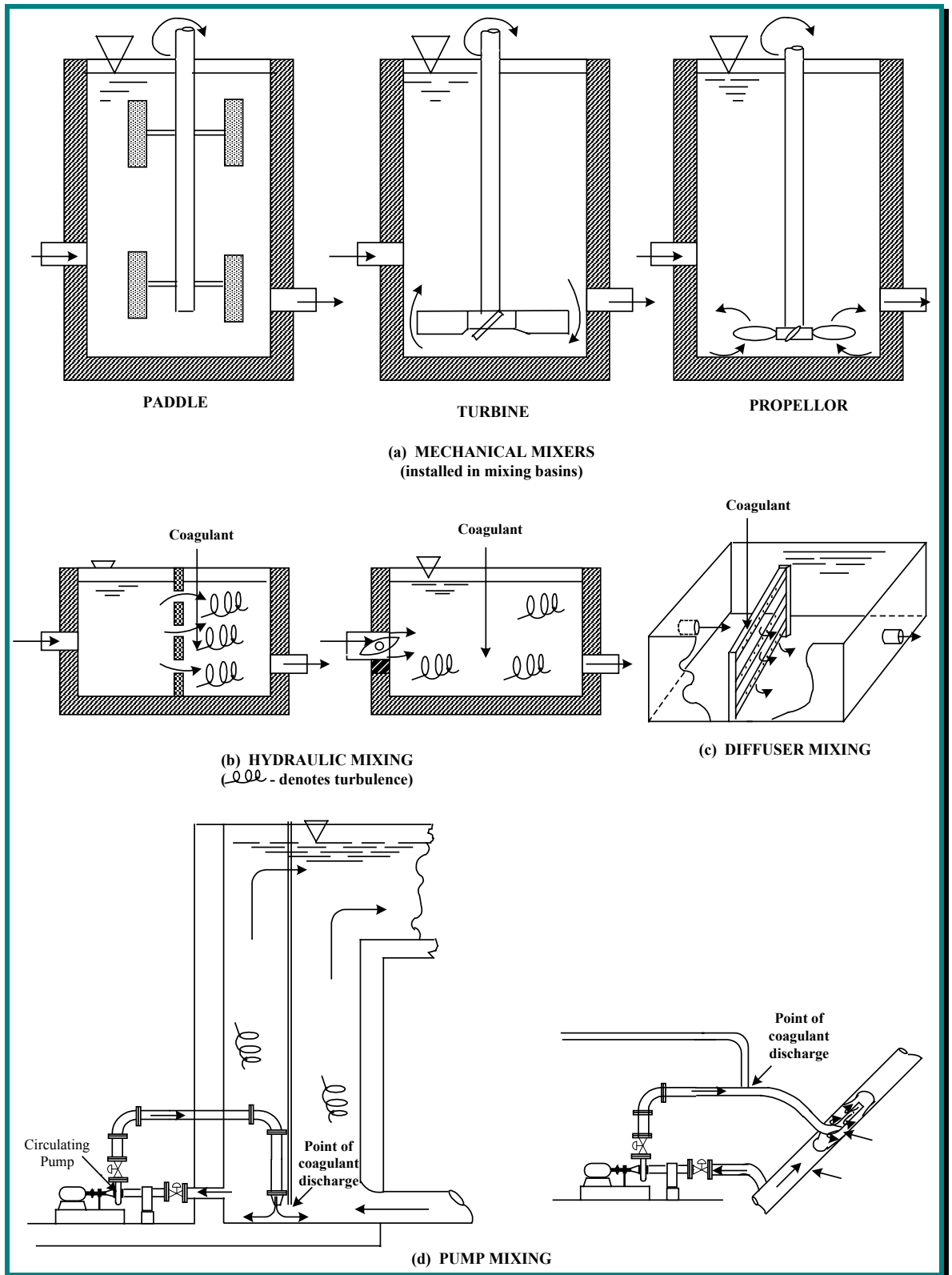

FIGURE 7: METHODS OF FLASH MIXING

## 4 FLOCCULATION

Flocculation is a process of gentle water movement that promotes the gathering together of the small floc particles (microflocs) produced by coagulation into larger masses better suited for removal by clarification processes.

### 4.1 PROCESS DESCRIPTION

The flocculation process provides conditions for contact between particles to promote their gathering together into flocs for ease of removal, mainly by clarification and finally by filtration. These contacts or collisions between particles result from gentle stirring created by a mechanical or other means of mixing, at a rate much slower than the mixing rate in coagulation, sometimes in dedicated flocculation basins. In hopper-bottomed upward-flow basins which utilize the sludge blanket effect these contacts or collisions between particles result from hydraulic mixing.

### 4.2 FLOC FORMATION

Floc formation is controlled by the rate at which collisions occur between particles and by the effectiveness of these collisions in promoting attachment between particles. The purpose of flocculation is to create a floc of a suitable size, density, and toughness for later removal in the sedimentation and filtration processes. The best floc size ranges from 0.1 mm to about 3 mm, depending on the type of removal processes used, the smaller floc size being best suited to direct filtration and the larger to removal by clarification.

Some flocculation can be accomplished by the turbulence resulting from the roughness in conduits or channels, or by the dissipated energy of head losses associated with weirs, baffles and orifices. Generally, these methods find only limited use owing to disadvantages such as very localised distribution of turbulence, inadequate detention time, and widely variable turbulence resulting from flow fluctuations.

### 4.3 PROCESS PERFORMANCE CONSIDERATIONS

Efficient flocculation involves the selection of the right detention time, the proper mixing intensity, a suitably shaped chamber or vessel for effective mixing to promote contacts between microflocs and the means, whether by mechanical equipment or otherwise, of creating the water movements required. Ineffective mixing will result in insufficient collisions and poor floc formation. Inappropriately vigorous mixing may tear apart flocculated particles after they have clumped together.

Separate flocculation chambers are very rarely found before hopper-bottomed upward-flow basins which utilize the sludge blanket effect. On solids -recirculation tanks, which also operate on the upward-flow principle, they are provided as part of the process.

#### 4.3.1 DETENTION TIME

While detention time is not usually a critical factor in the coagulation or flash-mixing process, in the flocculation process detention (stirring) time is *very* important. The minimum detention time recommended for flocculation, where separate flocculation chambers are provided, ranges from about 5 to 20 minutes for direct filtration systems and up to 30 minutes for conventional filtration. The size and shape of the flocculation facility also influence the detention time needed for optimum floc development.

#### 4.3.2 TYPES OF FLOCCULATORS (STIRRERS)

Two types of mechanical flocculators are in common use, where separate flocculation facilities are provided, vertical flocculators and horizontal paddle wheel types as shown in Figure 8. The mechanical mixers, of the propeller, paddle, or turbine types shown in Figure 7 (a) are identical in design to vertical flocculators but are run at slower speeds than those used in flash mixing. Both horizontal and vertical flocculator types can provide satisfactory performance. However, the vertical type usually require less maintenance since they eliminate submerged bearings and packings.

### 4.3.3 FLOCCULATION BASINS

The actual shape of flocculation basins or tanks is determined mainly by the flocculation system selected but partially by the need for compatibility with adjoining structures (clarification basins, filters). Flocculation basins for horizontal flocculators are generally rectangular in shape, while basins for vertical flocculators are nearly square. The depth of flocculation basins is usually about the same as that of horizontal flow sedimentation basins.

The best flocculation using mechanical flocculators, is usually achieved in a compartmentalised basin. The compartments (most often three) are separated by baffles to prevent short-circuiting of the water being

treated. The turbulence can be reduced gradually by reducing the speed of the mixers in each succeeding tank or by reducing the surface area of the paddles. This is called tapered-energy mixing. The reason for reducing the speed of the stirrers is to prevent breaking apart the large floc particles which have already formed. If the floc is broken up, it is unlikely to be removed in the clarification stage and overloading of the filters is probable, with consequent impaired quality in the water produced.

Hopper-bottomed, Figure 9, and other upward-flow basins, Figure 10, which utilize the sludge blanket effect, have a flocculation zone in the lower part of the hopper or basin. The sludge blanket is a very effective means of promoting contacts between sludge particles, as it strains smaller particles out of the rising flow.

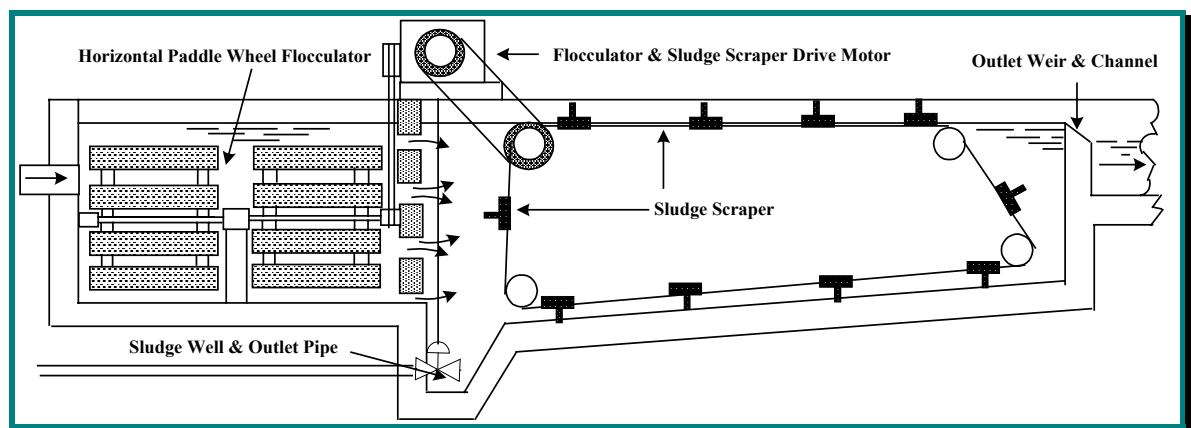

FIGURE 8: HORIZONTAL FLOCCULATOR AND HORIZONTAL FLOW SEDIMENTATION TANK

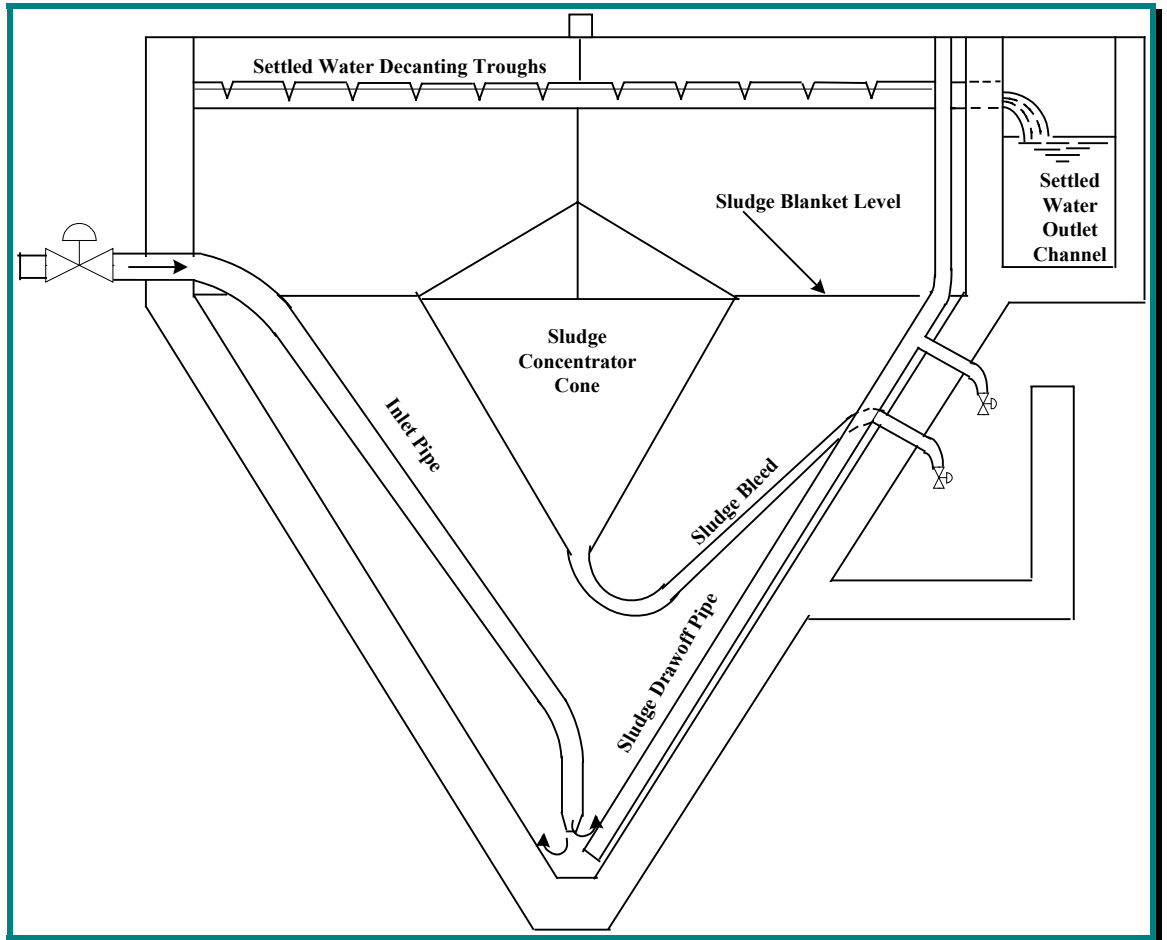

FIGURE 9: HOPPER BOTTOMED UPFLOW SLUDGE BLANKET SETTLEMENT TANK

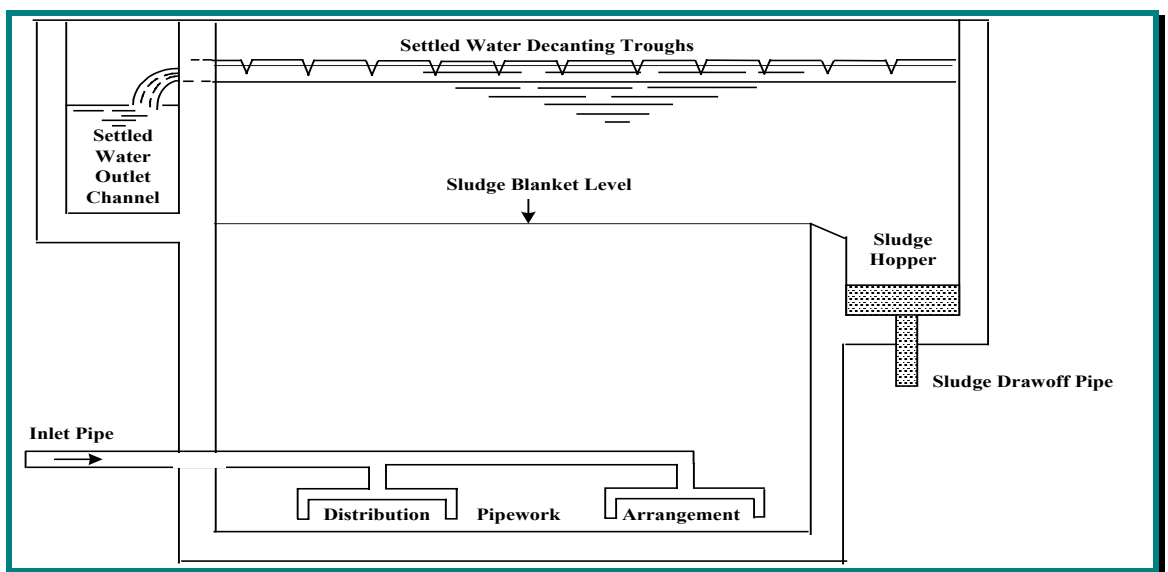

FIGURE 10: FLAT-BOTTOMED UPFLOW SLUDGE BLANKET SETTLEMENT TANK

## 5. CLARIFICATION

Clarification is the removal of suspended solids and floc from chemically treated water, before its application to filters. Essentially, coagulation, flocculation, clarification and filtration form an integrated solids separation process for the water and any shortcoming or failure in one segment has implications for the segments downstream. Except for filtration the segments are not rigidly separated from each other. Up to 90% of the suspended solids, floc, colour and turbidity should be removed in the prefiltration stages of treatment, in a properly functioning plant.

### 5.1 PROCESS DESCRIPTION

Water is clarified, in nature, by settlement when rivers run into lakes or similar enlargements and, as the rate of flow decreases, deposit their suspended solids. The natural process was copied in the original horizontal flow sedimentation (settling) tank. These tanks are now rarely used in public water supply in this country but are used in the treatment of silty tropical waters. Upward flow tanks, using the sludge blanket principle are the most widely used form of sedimentation in this country. In fact, in sludge blanket clarifiers, coagulation, flocculation and clarification may take place at different levels in the one tank at the same time.

Lakes and other still or slow-moving water bodies are often seen to have areas of green algal matter floating on their surfaces. It is difficult to remove this type of material by sedimentation in water treatment. Again copying nature, dissolved air flotation is often employed in the removal of this type of material after coagulation and flocculation. The choice of whether pre-filtration clarification is effected by settlement (sedimentation) or flotation depends on the whether the floc produced by coagulation tends to settle, to float or to have a neutral buoyancy.

### 5.2 THEORY OF SEDIMENTATION

Most of the suspended solids of concern in water treatment settle in accordance with Stokes' law :-

$$v_s = g(\rho_1 - \rho) \frac{d^2}{h}$$

where:

$v_s$  = velocity of settlement, as cm;

$g$  = 981 cm/s<sup>2</sup>;

$\rho_1$  = density of the particle, as g/cm<sup>3</sup>;

$\rho$  = density of the fluid, as g/cm<sup>3</sup>;

$h$  = dynamic viscosity of the fluid, as g/(cm s);

$d$  = diameter of the particle, as cm.

This equation basically gives the velocity of settlement of a particle in terms of the difference between the density of the particle and that of the suspending fluid, the diameter of the particle and the dynamic viscosity of the fluid. Dynamic viscosity varies inversely with temperature so that water at 0° C has twice the dynamic viscosity of water at 25° C. Settlement is therefore adversely affected by cold weather. The theory applies to *discrete* particles, while in the settling tank of a treatment works, the norm would be hindered settling.

### 5.3 CLARIFICATION BY SETTLEMENT

Clarification by settlement or sedimentation may take place in horizontal or vertical upward flow sedimentation tanks. Plain sedimentation in accordance with Stokes' Law is characteristic of the first, while the application of the sludge blanket principle typifies the latter in all its variations generically described as solids contact clarifiers. A new dimension to clarification by settlement has been added by the introduction of inclined tube or plate settlers into settlement tanks of all types to increase their settling efficiency.

#### 5.3.1 HORIZONTAL FLOW SEDIMENTATION TANKS

The earliest type of settlement tank used was the horizontal flow sedimentation basin or tank as shown in Figure 8. Water is admitted at one end and withdrawn over a weir at the opposite end. The horizontal flow settlement tank traditionally is rectangular in shape and of shallow depth. The sludge, which tends to settle near the inlet end, is removed from larger tanks, equipped with mechanical scrapers, by hydrostatic head.

Smaller tanks tend to be manually desludged after being drained. Horizontal flow tanks are occasionally used in this country in drinking water treatment as pre-settlement basins for removal of grit carried by mountain streams.

Circular radial flow sedimentation tanks are more usually associated with waste water treatment or industrial processes in this country than with drinking water clarification. They are used, particularly in tropical countries, for the treatment of heavily silted waters and are usually fitted with rotating sludge scrapers, which direct the sludge to a central hopper for removal. A variant on this tank, where space constraints so dictate, is the square radial flow sedimentation tank, with curved corners at bottom negotiated by a specially designed telescoping rotating sludge scraper.

### 5.3.2 VERTICAL FLOW SEDIMENTATION TANKS

As noted above, many of the treatment plants in this country include hopper bottomed tanks, formed as inverted pyramids with tank sides sloped at 60° to the vertical as shown in Figure 9. Chemically treated water is discharged downwards to impinge on the base of the tank. Depending on the time interval since the injection of the chemicals, coagulation is completed as the water is discharged. The water turns through 180° and flocculation occurs as the turbulence at discharge reduces while the water flows upwards and its velocity decreases, as the cross sectional area of the tank increases.

The upwards velocity of the water continues to decrease until, at a given level, the force of the upward flow on the floc particles just counterbalances the downward weight of the particles, which therefore hang suspended in the water. They form a cloud or blanket of flocculated particles which provides conditions favourable to contacts between particles in the rising water and those in the blanket. Chemical and physicochemical reactions can be completed in the blanket and a straining action to remove some of the finer particles from the rising water takes place. Studies by the Water Research Centre in the U.K. on floc blanket clarification show that the principal clarification mechanism of a floc blanket, at normal concentrations of floc in the blanket, is mechanical entrapment. In the floc blanket type of upflow settling tank, rates in the range 1 m/hr to 3 m/hr are normally encountered,

the choice being largely dependent upon the raw water quality. A lowland water with high alkalinity and low colour would tolerate a rise rate at the top end of the range, whilst a thin, coloured water producing a weak floc would only tolerate a rise rate at the low end of the range.

Other shapes and designs of tank utilizing the sludge blanket principle for flocculation as well as clarification have been developed, one of which is illustrated in Figure 10. Another of these, also with a flat bottomed vertical wall configuration, uses a vacuum chamber built on the main inlet channel. Chemically treated raw water is discharged downward by a series of evenly spaced perforations in laterals from the main inlet channel. The filling and emptying of the vacuum chamber induces intermittent flow through the tank and cause the top of the floc blanket to be alternately raised and lowered. The raising and lowering of the blanket is designed to consolidate and maintain a uniform floc density throughout the blanket and, at the point when the level is raised, to permit surplus floc to flow over a weir into concentrators for removal.

### 5.3.3 SOLIDS CONTACT CLARIFIERS

Solids contact clarifiers are also known as upflow clarifiers, reactivators and precipitators. The basic principle is that sludge produced by the unit is recycled through the process to act as a coagulant aid, thereby increasing the efficiency of the processes of coagulation, flocculation and sedimentation. The tank is circular with sidewall sloped outward at 45°, flat-bottomed with an internal conical hood sloped at 45° as shown in Figure 11. This hood divides the tank into two zones. Raw water and coagulants are mixed in the inner zone and flow to the outer chamber which acts in similar fashion to the hopper-bottomed upward-flow tank described above. The 'hopper' is formed by the shaped hood which forms the inner wall of the annular space. The surface area of this space is dimensioned to provide the same upward flow velocities which control the dimensions of any upward-flow tank. Water is normally drawn off over radial launders spaced at regular intervals to ensure uniform upward velocity. Preformed sludge is recirculated from the bottom of the hopper to the central primary reaction zone or, if surplus to requirements drawn off to waste.

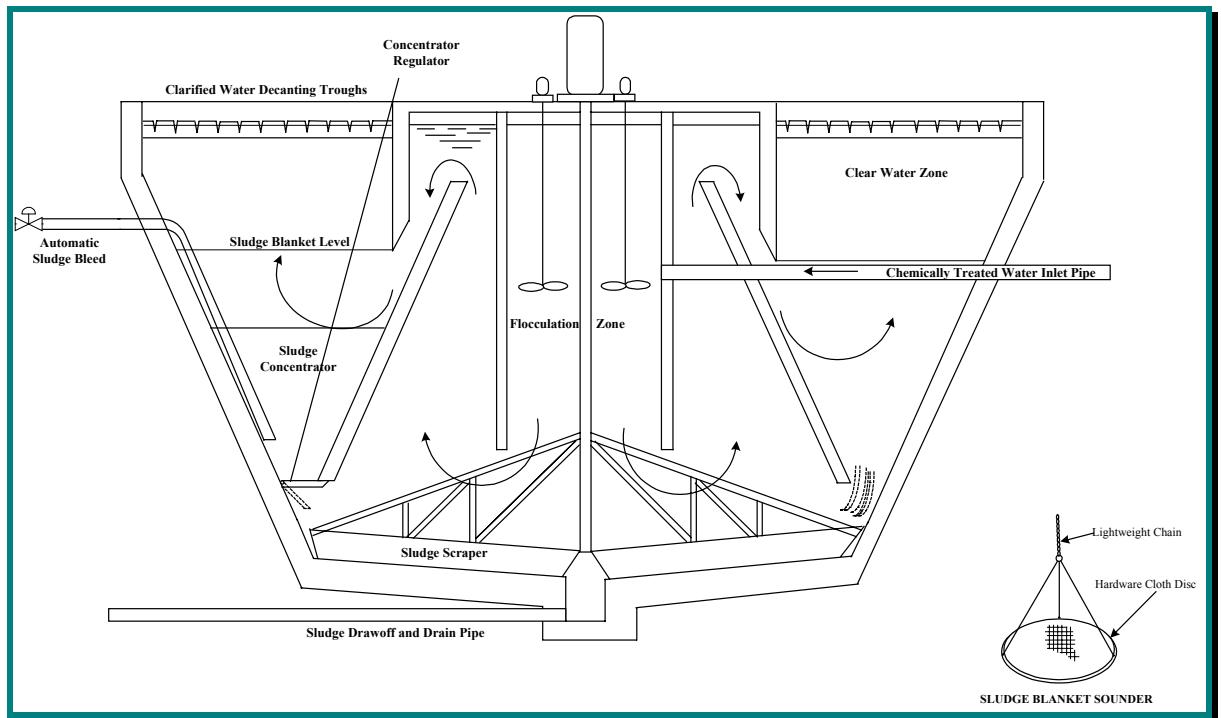

FIGURE 11: SOLIDS CONTACT CLARIFIER

#### 5.3.4 HIGH RATE CLARIFIERS

The principle that horizontal flow sedimentation tanks should be as shallow as possible in order to shorten the falling distance for particles was stated by Hazen at the beginning of this century. The problem with designing full-scale tanks on this principle is that a fairly light breeze will ruffle the surface and cause enough turbulence to resuspend already settled sludge. The depth of sludge would be a significant part of the total depth of the tank unless it were desludged very frequently.

The principle stated by Hazen is used in high rate clarification where water being settled is directed upwards through a series of tubes or between a series of plates, inclined at about  $60^\circ$  to the horizontal. The tubes or plates effectively form a series of shallow tanks which theoretically offer optimum conditions for sedimentation. The solids settle to the inclined surfaces and slide downwards to be withdrawn from the bottom of the clarifier. The tubes or plates are of plastic material and made up in packs. Such packs have been used to uprate existing clarifiers where water demand has increased beyond the original design figure and are also incorporated into some newly designed high rate clarifiers.

#### 5.3.5 DESLUDGING SETTLEMENT TYPE CLARIFIERS

Effective removal of sludge is very important for the efficient operation of clarifiers. With a raw water having suspended solids not greater than say 250 mg/l the sludge to be removed should be a maximum of about 3% of throughput. Continuously operating sludge removal systems are usually wasteful of water, except in the case of those waters with high suspended solids content. Circular radial flow and horizontal flow sedimentation tanks are usually equipped with mechanical sludge scrapers as mentioned previously.

In order to maintain a steady situation in a hopper bottomed upward flow sedimentation tank, solids must be withdrawn regularly at a rate equal to the influx of solids in the dosed water less the quantity that should be carried to the filters. Failure to withdraw sufficient sludge can result in an accumulation of solids and carry over to the filters; attempts to remove too much sludge can result in failure to establish a proper blanket. Ideally the sludge bleed from a floc blanket tank should be intermittent and via a sludge concentrator hopper in order to allow sludge to be removed at as high a solids content as possible.

About 1 to 2% of the total volumetric tank throughput should be withdrawn as sludge, the bleed running for 2 or 3 minutes every 30 minutes or so. This can be carried out manually or by process timer.

The basic mechanism employed for sludge removal is to provide a weir over which sludge can flow from the blanket when concentrated sludge is drawn off from behind the weir. In hopper bottomed upward flow tanks the top of the sludge blanket is kept approximately at the level where the tank sides sloped at 60° meet the vertical upper portion of the tank. The sludge weir has been placed in various positions and with different configurations in the tank, a recent development being a PVC-impregnated nylon cone suspended near the level of the top of the floc blanket. The weight of sludge in the cone is monitored and the draw-off of sludge is controlled automatically. The original design of hopper bottomed upward flow tanks usually had sludge collectors or concentrators near the bottom of the vertical walled section of the tank. Concentrated sludge is withdrawn under the hydrostatic head of the water above the sludge concentrator, via a valved drawoff pipe. Sludge from the blanket migrates to displace the clearer water in the space left by the evacuation of sludge from the concentrator.

It is necessary to know the level of the surface of the sludge in any sedimentation tank in order to plan sludge removal operations and in sludge blanket tanks to keep check on the level of the blanket. Large sophisticated works may have an ultrasonic level indicator for this purpose but for smaller works simpler and cheaper methods are needed. The simplest measuring device is a sounder, as shown inset on Figure 11, made from 6 mm thick hardware cloth, similar to the material used on radars and radio-telephone dishes. A disc of this material about 500mm diameter is suspended from a lightweight chain by a three point suspension. The disc is slowly lowered into the sedimentation tank and when it reaches the top of the sludge blanket its descent stops and a depth reading is taken from markings on the chain.

When conditions are stable and a suitable regime of sludge drawoff has been established, the need for sludge depth measurements is slight, except possibly to record that no change had occurred. Any change in coagulant dose rate involves a change in the regime of sludge drawoff to re-balance it with the new rate of influx of solids in the water.

## 5. 4 FLOTATION

It can be seen from the equation given in Section 5.2 (Stokes Law) that when the left hand side has a positive value particles will settle, while if the value is negative particles will rise and float. Certain suspended solids like algae are lighter than water and float unless treated by weighting with a clay such as bentonite. If air bubbles attach themselves, even heavier particles can be made to rise. In a flotation plant, a fraction of the throughput is passed through an air vessel and brought into contact with air at 5 - 6 atmospheres pressure. The supersaturated water is reinjected into the main flow at the base of the flotation vessel and with the use of special equipment microbubbles of air are released and diffused through the incoming coagulated and flocculated water. The bubbles become attached to the floc particles and cause them to float to the surface where the sludge, with a much higher solids content than sludge from a settlement tank, can be scraped from the flotation tank as shown in Figure 12.

## 5.5 INTERACTION WITH COAGULATION AND FLOCCULATION

The removal, in a clarifier or dissolved air flotation tank, of suspended matter from water, especially matter of a colloidal nature, depends on the previous conditioning of the matter to be removed. Apart from settleable solids, there will be no particles to settle or float unless flocculation takes place. Flocculation presupposes coagulation with the proper selection, preparation, application and mixing of the coagulant chemicals in the correct order, with suitable delays. The subsequent slow stirring to promote flocculation, whether in separate flocculation basins or other processes such as passage through a floc blanket tank will effectively prepare the coagulated matter for removal in the clarification stage.



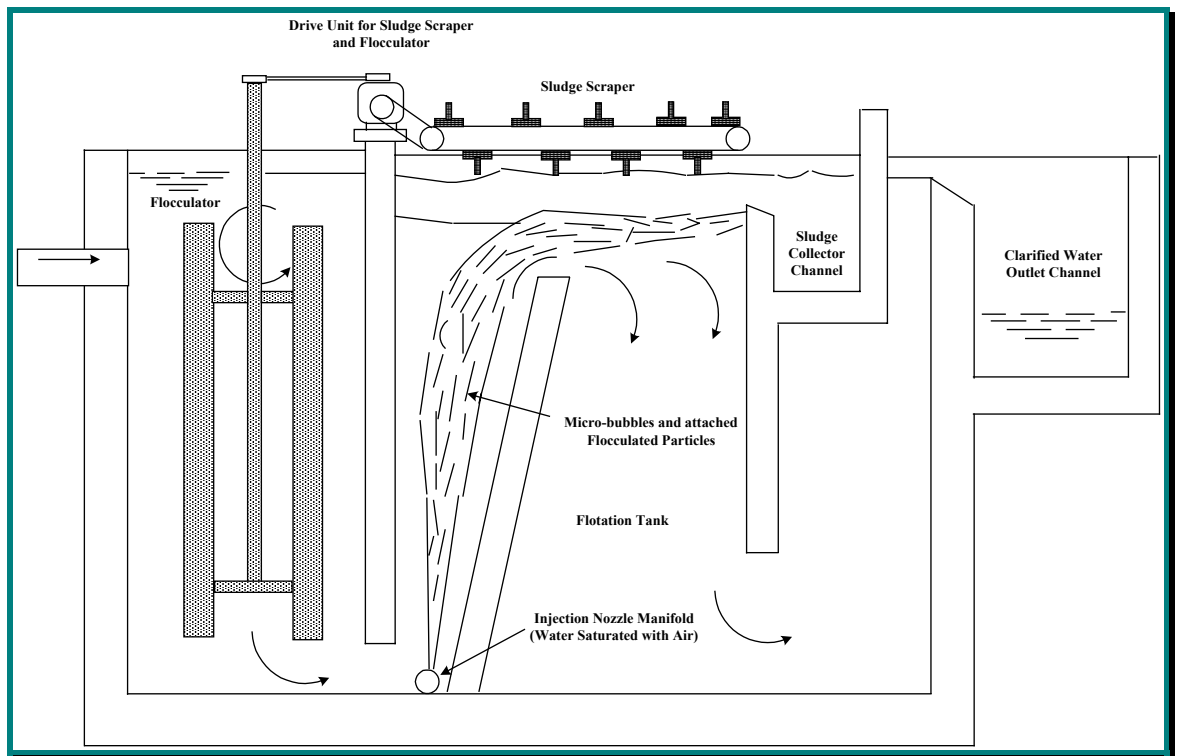

FIGURE 12: DISSOLVED AIR FLOTATION UNIT

## 5.6 MODIFICATION TO TREATMENT PROCESS

It is essential that, before any modification is made to the treatment process, an overview is taken of at least the total solids separation part of the process and preferably of the entire treatment process. This is necessary to assess the possible knock-on effects of any proposed modification of one segment on other segments of the treatment process, because of the close linkage between the various segments. Incautious or not fully considered use of polyelectrolytes to promote coagulation / flocculation, say to counteract the adverse effects of an algal bloom in the raw water supply, might result in improved operation of the clarification segment but permit a carry-over of polyelectrolytes on to the filters and result possibly in binding of the surface or cracking of the filter media. In recent years, comparatively minor changes to treatment processes at major waterworks in other countries have had serious

consequences including outbreaks of waterborne cryptosporidiosis.

## 5.7 PILOT PLANT TESTING OF MODIFICATIONS

Notwithstanding that careful and detailed consideration has been given to a modification proposed to be made to the designed treatment process, and assessment of the most likely outcome, there can be no guarantee that the outcome will be successful. When a treatment works is the major or sole provider of water in an area any adverse reaction to a change could have serious consequences resulting in the supply to consumers of water, which did not reach the required standard set by law. The only satisfactory solution to the dilemma is to have a pilot plant, so that the effects of a proposed modification can be checked using the actual water to which it will be applied and the process that will be used in its treatment.

## 6. PROCESS CONTROL

### 6.1 OPERATING PROCEDURES ASSOCIATED WITH NORMAL PROCESS CONDITIONS

From a water quality standpoint, filter effluent turbidity is a good indication of overall water treatment process performance. However, the performance of each of the individual water treatment processes must still be monitored, in order to anticipate quality or performance changes. Normal operating conditions are considered to be conditions within the operating ranges of the plant, while abnormal conditions are unusual or difficult to handle conditions. Changes in raw water quality may be considered a normal condition for many plants using a run-of-river source but an abnormal condition for other water treatment plants using stored water sources.

Coagulation-flocculation is a pretreatment process for the clarification and filtration processes. Most of the suspended solids are removed in the clarification basins and filtration is the final step in the solids removal process. The coagulation-flocculation process should be operated and controlled to improve clarification and also filtration and thus produce a filtered water which is low in colour, turbidity and residual coagulant.

Visual observation is the most important component of any system of process control, even in a highly automated plant. For instance a rainstorm may be observed in the headwaters of the river feeding a run-of-the-river plant. It will be known that turbid water will be arriving at the plant after a certain approximate length of time. Plant records can be consulted in the interval to determine the likely water quality to be expected in terms of turbidity, pH, temperature and colour and the dosage of coagulants found appropriate for such water on previous occasions, before the turbid water arrives at the intake point and measurements of actual water quality parameters on the day can begin. Similarly, in walking through the plant a small boil observed in an upflow sedimentation tank may indicate the onset of sludge blanket instability or merely that a piece of light plastic film blowing in the wind has got into the tank and is causing local turbulence.

The measurement of filtered water turbidity on either a periodic basis (grab sample) or continuously by means of a turbidimeter will give the operator a good indication of overall plant performance. However, the operator cannot rely solely on filtered water turbidity for complete process control. The difficulty in relying on a single water quality indicator such as filtered water turbidity is the time that it takes the water to pass through the various treatment processes. Depending on the configuration of the plant and the amount of water being processed, the total transit time through the treatment plant can vary from 2 to 6 hours or more. This means that the effect of a change in coagulant dosage at the start of treatment will not be detectable in the final finished water quality for a period of 2 to 6 hours or more. Therefore turbidity as well as other water quality indicators such as pH, temperature, chlorine demand, and also floc quality must be monitored throughout the water treatment process. Poor process performance can thus be detected quickly and corrective measures can be adopted.

#### 6.1.1 MONITORING REGIMES

A schematic representation of monitoring requirements for coagulation / flocculation / clarification processes is presented in Figure 13. This must be interpreted, for a specific plant, in the light actual selection of unit processes employed there e.g. a plant with hopper bottomed upward flow settlement tanks will normally have flash mixing and flocculation occurring in the settlement tank and will not have separate basins for these processes.

##### 6.1.1.1 Monitoring Common to All Works

#### RAW WATER PRIOR TO COAGULATION

- Turbidity
- Temperature
- Colour
- Alkalinity
- pH

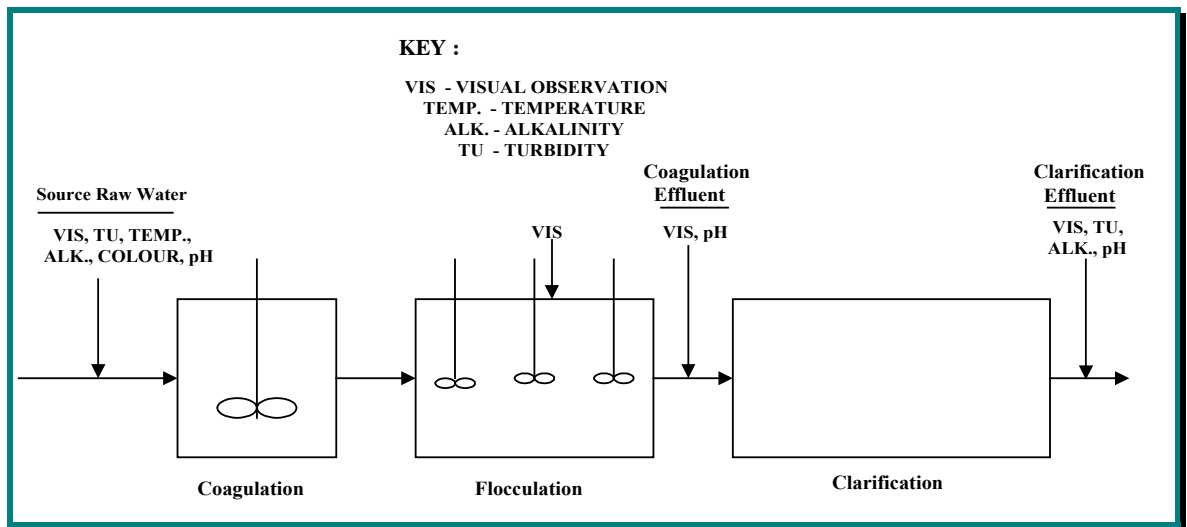

**FIGURE 13: COAGULATION-FLOCCULATION-CLARIFICATION PROCESS**

Visual observation should be made of the status of screens if the raw water sampling point is close to them. Jar Tests should be carried out if any of the water quality parameters show significant variation from the results of previous monitoring.

#### **6.1.1.2 Monitoring in Works with Upward Flow or Solids Contact Clarifiers**

Monitoring, in the operation of the coagulation / flocculation / clarification process in plants where upward flow or solids contact clarifiers are used would include:

##### **1 CLARIFICATION BASIN**

- Visual observation of clarification basin
- Depth measurement from surface to blanket

The appearance of floc in water being flocculated and settled is evident when the sun shines on the water and one stands so as to observe the light reflected by the floc. Submerged lights, near the outlets of flocculation and sedimentation basins, shaded to prevent light, except that reflected by the floc, reaching the observers eye facilitate observation at any time. In the absence of such lights, a shaded light above water level may be used, but this has the disadvantage that some light will reflect from the water surface, making the floc less evident.

##### **2 CLARIFICATION EFFLUENT**

- Turbidity
- Alkalinity
- pH
- Total and dissolved coagulant in grab sample

Any problems not detected at the pre-coagulation stage can only become manifest after the clarification stage in effluent turbidity. Continuous turbidity monitors may be used in larger plants but for smaller works or for a quick check on conditions during a walk-through inspection of the plant, a turbidity rod is a quick and useful practical guide to turbidity. The rod is made by fixing two bright platinum wires, one 1mm diameter and the other 1.5mm diameter, at right angles to the bottom of a rod marked in centimetres. The depth of immersion, at which one wire disappears while the other remains visible when viewed from above, is related to turbidity as follows :

DEPTH OF IMMERSION (cm)	TURBIDITY (mg/l SiO )	NOTES
2 10	1000 100	Filter clogs quickly
15	65	Filters operate with difficulty
30 45	30 18	Special care in filter operation required
80	10	Maximum desirable limit for filtration

### 6.1.1.3 Monitoring in Works with Dissolved Air Flotation or Horizontal Flow Clarifiers

Monitoring, where there are separate basins for flash mix and flocculation with dissolved air flotation clarification or horizontal flow sedimentation tanks would include:

#### i) Flash Mix (Coagulation) Effluent

- pH
- Alkalinity
- pH
- Visual observation of effluent.

#### ii) Flocculation Basin

- Visual observation of flocculation basin

The degree of agitation in flocculation basins may be estimated by using chaff from paper punches, confetti or other inert floating material thrown into the water to be carried by the eddy currents under observation.

#### iii) Flocculation Effluent

- Turbidity
- Temperature
- Alkalinity
- pH
- Total and dissolved coagulant in grab sample
- Visual observation of effluent.

#### iv) Clarification Basin

- Make visual observation of clarification basin
- Depth measurement from surface to sludge

#### v) Clarification Effluent

- Turbidity
- pH
- Alkalinity
- pH Total and dissolved coagulant in grab sample

### 6.1.1.4 General Matters Regarding Monitoring

Turbidity of the water entering the clarification tank or basin, only observable where separate flocculation basins are provided, indicates the floc or solids loading on the clarification process. Turbidity of the water leaving the basin reveals the effectiveness or efficiency of the clarification process. Low levels of turbidity in the clarified water are desirable to minimise the floc loading on the filters.

Temperature of the water entering the clarification basin is very important. Usually water temperature changes are gradual, depending on time of the year and the weather. As the water becomes colder, particles settle more slowly. To compensate for this change, jar tests should be performed and adjustments made to the coagulant dosage to produce a heavier and thus a faster settling floc. Another possibility is that if the demand for water decreases during colder weather, the flow to be treated is reduced which will produce longer detention times. Longer detention times will allow slower settling particles or floc to be removed in the clarification basins or tanks.

Visual checks of the sedimentation process, in horizontal flow basins, should include observation of floc settling characteristics, distribution of floc at the basin inlet, and clarity of settled water spilling over the launder weirs. An uneven distribution of floc, or poorly settling floc may indicate that a raw water quality change has occurred or that operational problems have developed. In plants where upward flow or solids contact clarifiers are used, the surface of the sludge blanket should be observed for any unusual conditions, its depth from surface measured and again clarity of settled water spilling over the launder weirs.

Process control guidelines for a specific plant are often developed to assist the operator in making these determinations. These guidelines are partially based on theory and partially based on experience, but also must be combined with practical knowledge of the source water conditions as well as known performance characteristics of the treatment facilities used for a variety of different treatment conditions.

### 6.1.2 PROCESS ACTIONS

In the normal operation of the coagulation-flocculation-clarification process, the operator performs a variety of jobs within the water treatment plant. The number and type of functions that each operator will perform vary considerably depending on the size and type of plant and the number of people working in the plant. In smaller plants, the operator is required to control almost all process actions as well as perform most routine maintenance activities. Regardless of the plant size, *all* operators should be thoroughly familiar with the routine and special operations and maintenance procedures associated with each treatment process.

Typical jobs performed by an operator in the normal operation of the coagulation-flocculation-clarification process include the following:

- Monitor process performance,
- Evaluate water quality conditions (raw and treated water),
- Check and adjust process controls and equipment, and
- Visually inspect facilities.

Monitoring process performance is an ongoing activity. Filtered water turbidity levels are controlled to a great extent by the efficiency of the coagulation-flocculation-clarification process.

Early detection of any pretreatment upset or failure is extremely important because, as noted previously, considerable time elapses while the water flows through the coagulation, flocculation, clarification and filtration processes.

Process performance can be monitored with the aid of continuous water quality analysers which automatically measure a specific water quality indicator such as turbidity. However, reliable and accurate water quality analysers are expensive and, in many cases, automated equipment is not readily available for measuring water quality indicators of concern to the operator. Thus, a combination of techniques must be used to evaluate process performance including visual observations and periodic laboratory tests to supplement any continuous water quality monitors.

Visual observations, using the turbidity rod mentioned in Section 6 and tests of coagulation-flocculation-clarification process performance should be carried out on a routine basis. The most common laboratory tests are for turbidity, alkalinity, pH, colour, temperature, and chlorine demand. The frequency of these observations and tests depends on how much the quality of the source water supply can or does change. In treatment plants where the source water is stored in a large upstream lake or reservoir, the water quality is generally more stable or constant than that of water taken directly from rivers or streams, unless the water is affected by algal growths. In the case of direct abstractions from a stream or river, water quality conditions will vary seasonally as well as daily. In extreme cases (during heavy runoff periods) even hourly changes in source water quality can be expected. Thus, the appropriate frequency of performing certain tests may be as often as hourly, or perhaps only once per eight-hour shift.

In upflow or solids-contact clarifiers the surface of the sludge blanket should be observed for any unusual conditions. The depth of the sludge blanket and its density are useful parameters to monitor. If the sludge blanket is of normal density (measured as milligrams of solids per litre of water) but is very close to the surface, more sludge should be wasted. If the blanket is of unusually light density, the coagulation-flocculation process (chemical dosage) must be adjusted to improve performance. These observations are frequently supplemented by laboratory evaluations, which are necessary to provide numerical data.

With any of the clarification processes, it is useful to observe the quality of the effluent as it passes

over the launder weir. Floccs coming over the outlet weir are indicative of density currents, short-circuiting, sludge blankets that are too deep, or high flows. The clarity of the effluent is also a reliable indicator of coagulation-flocculation efficiency.

Visual checks of the coagulation-flocculation process, only possible where separate coagulation and flocculation basins are provided, generally include an observation of the turbulence of the water in the flash-mixing channel or chamber (improper flow patterns can be seen), and close observations of the size and distribution of floc in the flocculation basins or in the floc blanket. An uneven distribution of floc could be an indication of short-circuiting in the flocculation basin. Floc particles which are too small or too large may not settle properly and could cause trouble during removal in the following processes, if sedimentation is the clarification process employed. Again laboratory evaluations similar to those noted above will be needed if there is a problem with the process, a most useful indicator of which is the clarity of settled water spilling over the launder weirs.

Based upon an overall evaluation of process performance, minor changes in chemical feed dosages or adjustment of the speed of the flash mixer or flocculators, if variable-speed units are provided may be needed. These are normal actions associated with minor changes in source water quality such as turbidity or temperature fluctuations. Flash mixers are generally less sensitive to speed adjustments than flocculators since their primary purpose is to disperse the chemicals rapidly into the water being treated. This reaction is almost instantaneous in such small quantities.

Adjustment of flocculator speed of rotation, if such a feature is provided, should take into account the following factors:

1. Volume of floc to be formed. If source water turbidity is low, a small pinpoint floc may be best suited for removal on the filters (direct filtration). Lower flocculator speeds are appropriate here. On the other hand, high turbidity source waters generally require near-maximum flocculator speed to produce a readily settleable floc.
2. Visual observations. Short-circuiting may indicate flocculator mixing intensity is not sufficient, while floc breakup is an indication that the mixing turbulence (speed) may be too high for the type of floc formed (large alum floc).

3. Water temperature. Lower water temperature requires higher mixing turbulence, so speed should be increased.

Unfortunately, these factors, with the exception of water temperature, are not easily measured. Experience and judgement are needed. One of the real limitations in process control is too much reliance on the settled water turbidity value. While turbidity gives an indirect measurement of suspended solids concentration, it does not describe particle size, density, volume, nor the ability of a particular filter to handle the applied waters.

In rectangular and circular settlement basins, a judgement about the performance of the settlement process can generally be made by observing how far the floc are visible beyond the basin inlet. When settlement is working well, the floc will only be visible for a short distance. When settlement is poor, the floc will be visible for a long distance beyond the inlet.

Process equipment such as chemical feeders should be checked regularly to assure that they are accurately feeding the desired amount (feed rate) of chemical. Operation and maintenance of process equipment is discussed in more detail in Section 8.3. Proper operation of manually controlled sludge removal equipment should be verified each time the equipment is operated, since sludge removal discharge piping systems are subject to clogging. The operation of automatically controlled sludge removal equipment should be monitored on a regular basis and the discharge sampled occasionally. Free-flowing sludge can be readily observed if sight glasses are incorporated in the sludge piping. Frequent clogging of the sludge discharge line is an indication that the sludge concentration is too high. If this occurs, the operator should increase the frequency of operation of the sludge removal equipment. This problem can be accurately diagnosed by performing a sludge solids volume analysis in the laboratory, if this capability is available to the operator.

The overall coagulation-flocculation-clarification physical facilities should be visually inspected on a routine basis as a part of good housekeeping practice. Leaves, twigs, and other debris can easily build up in the influent channel or in the flocculation or clarification basins or launders. If ignored, such material may get into other processes where it can foul meters, water quality monitors, pumps or other mechanical equipment. In some cases taste and odour problems can develop from micro-organisms that can grow in debris and sediment which accumulate in plant

facilities. Abnormal equipment conditions should be corrected or reported to maintenance personnel. Table 1 presents a summary of routine coagulation-flocculation-clarification process actions.

## **6.2 OPERATING PROCEDURES ASSOCIATED WITH ABNORMAL PROCESS CONDITIONS**

### **6.2.1 INDICATORS OF ABNORMAL CONDITIONS**

Sudden changes in the source water or filtered water turbidity, pH, alkalinity, temperature or chlorine demand are signals that an immediate review of the performance of the coagulation-flocculation-clarification processes is required. The onset of heavy rain or other major changes in meteorological conditions in the catchment supplying the works is a signal to anticipate change in the source water. Notice or warning of the accidental or other discharge of dangerous material to waters upstream of the intake means that preparations must be made to shut down the threatened intake at short notice and switch to an alternative source if available or close down the works.

### **6.2.2 PROCESS ACTIONS**

Changes in source water turbidity levels, either increases or decreases, generally require verification of the effectiveness of the coagulant chemicals and dosages being applied. This is best accomplished by performing a series of jar tests in the laboratory as discussed previously. Decreasing raw water turbidity levels can be just as upsetting to the process as increasing levels.

Visual observations of flash-mixing intensity as well as the condition of the floc in the flocculation basins may also indicate the need for process changes such as adjustment of mixer speed or coagulant dosage. Alkalinity, pH, and temperature changes in the source water may have an impact on the clumping together of floc during the coagulation-flocculation process. In addition, water temperature changes may require an adjustment in the level of mixing intensity in flash mixers or flocculators. Decreasing water temperatures lower the rate at which particles settle, while higher water temperatures increase particle settling velocities. Thus, temperature changes may also require that jar tests be performed to establish optimum floc settling rates. Temperature changes are usually gradual over

time so sudden changes in temperature are unlikely unless a source water change is made.

Consistency in quantity or rate of supply is normally readily controllable and is a fundamental requirement for the proper operation of sedimentation systems. This becomes increasingly important for floc blanket systems treating thin coloured waters where even very slight disturbances can lead to disruption of the floc blanket, which is then swept over to impose an extra load onto the filtration stage, often resulting in poor filtered water quality. Any changes required in flow rate should be introduced as smoothly as possible, for instance if a sedimentation tank is to be taken "off-line" for some reason and its throughput distributed over the remaining tanks.

Sudden increases in settled water turbidity could spell trouble in the operation of the filtration process. Floc carryover from the sedimentation tank will cause premature clogging of filters and may result in the degradation of filtered water quality. Sudden increases in filtered water turbidity could be caused by poor filter performance (need for backwashing or replacing filter media). However, poor coagulation-flocculation-clarification performance is usually the culprit, and immediate action to correct the problem should be taken, remembering that several hours may pass before the effect of changes in the operation of the coagulation-flocculation process are seen in the filter effluent. The use of a filter-aid chemical such as a nonionic polymer, fed directly to the filter influent would not be in conformity with Irish practice. While this might solve the short-term problem, only changes in the coagulation-flocculation process will enhance long-term plant performance. Again, the results of laboratory jar tests should be used as the basis for making process changes.

Table 2 is a summary of coagulation-flocculation-clarification process problems, how to identify the causes of these problems, and also how to go about trying to correct the problems.

**TABLE 1: SUMMARY OF ROUTINE COAGULATION-FLOCCULATION-CLARIFICATION PROCESS ACTIONS**

<b>Steps</b>	<b>Location</b>	<b>Frequency</b>	<b>Possible Operator Actions</b>
<b><i>To Monitor Source Conditions and Water Abstraction</i></b>			
<ol style="list-style-type: none"> <li>1. Measure air and water temperature and take water sample for test/analysis.</li> <li>2. Note source water conditions and read level gauge (if fitted).</li> <li>3. Record weather conditions and any bad weather forecast.</li> </ol>	Raw water Intake or Works Inlet	Daily	<ul style="list-style-type: none"> <li>• Clean/Backwash screen as appropriate.</li> <li>• Select inlet at most appropriate intake level for prevailing conditions (lake intake).</li> </ul>
<b><i>To Evaluate Water Quality and Monitor Coagulation/Flocculation</i></b>			
<ol style="list-style-type: none"> <li>1. Measure water parameters<sup>1</sup> and Colour (Raw water)</li> <li>2. Carry out jar test.</li> <li>3. Observe flash-mixer turbulence and microflocs.</li> <li>4. Observe floc size and distribution.</li> <li>5. Prepare coagulant and chemical solutions</li> </ol>	Laboratory  Laboratory Flash mixer  Flocculation chambers Solution Tanks	Daily in steady conditions in raw water. Depends on conditions. Every 2 hours.  Every 2 hours.  Daily	<p>Compare values of parameters with recent results. Adjust coagulant dose in accordance with plant guidelines as required. Adjust mixer intensity.</p> <p>Adjust flocculator speed.</p> <p>Check Twaddell hydrometer reading of solutions</p>
<b><i>To Monitor all Clarifiers</i></b>			
<ol style="list-style-type: none"> <li>1. Check physical facilities and for algae buildup on walls, launders and channels.</li> <li>2. Observe quality of clarified water spilling into outlet channels.</li> <li>3. Check water parameters and total and dissolved metal content of clarified water.</li> </ol>	All Clarifiers	Daily.  Every 2 hours.  Daily.	<p>Report abnormal conditions.</p> <p>Adjust coagulant dose in accordance with plant guidelines.</p> <p>Adjust coagulant dose in accordance with plant guidelines.</p>
<b><i>To Monitor Operation of Solids Contact and Upflow Sludge Blanket Clarifier</i></b>			
<ol style="list-style-type: none"> <li>1. Observe sludge blanket for boiling or instability.</li> <li>2. Measure depth from surface to blanket.</li> <li>3. Check water on top of blanket by turbidity rod.</li> <li>4. Check operation of sludge bleed and sludge draw-off.</li> </ol>	Clarifier	Every 2 hours.  Every 2 hours.  Every 2 hours.  Daily.	<p>Adjust coagulant dose in accordance with plant guidelines if required.</p> <p>Measure depth to sludge blanket with sounder and record.</p> <p>Take sample for laboratory analysis if any significant change found.</p> <p>Adjust bleed rate and clear sludge line. as required.</p>
<b><i>To Monitor Operation of Dissolved Air Flotation Clarifier</i></b>			
<ol style="list-style-type: none"> <li>1. Observe sludge float and operation of sludge scraper.</li> <li>2. Check solids content of sludge float.</li> </ol>	Flotation tank	Every 2 hours.  Weekly.	<p>Adjust scraper speed if required.</p> <p>Adjust coagulant dose in accordance with plant guidelines.</p>
<b><i>To Monitor Operation of Other Types of Clarifier</i></b>			
<ol style="list-style-type: none"> <li>1. Observe floc size, distribution and settling characteristics.</li> <li>2. Measure depth from surface to top of sludge.</li> </ol>	Horizontal flow tank.	Daily.	<p>Adjust coagulant dose in accordance with plant guidelines.</p> <p>Check sludge draw-off for satisfactory operation. Desludge as required.</p>

<sup>1</sup> Water Parameters = Turbidity, pH, Alkalinity



TABLE 2: COAGULATION-FLOCCULATION-CLARIFICATION PROCESS TROUBLESHOOTING

Indicator	Operator Actions	Possible Process Changes
<b>1. In Source Water Quality</b>		
Changes in: <ul style="list-style-type: none"> <li>• Turbidity</li> <li>• Temperature</li> <li>• Alkalinity</li> <li>• pH</li> <li>• Colour</li> </ul>	<ul style="list-style-type: none"> <li>• Perform necessary analyses to determine extent of change.</li> <li>• Evaluate overall process performance</li> <li>• Perform jar tests if indicated.</li> <li>• Make appropriate process changes (see right-hand column, Possible Process Changes).</li> <li>• Increase frequency of process monitoring until plant stabilises</li> <li>• Verify response to process changes at appropriate time (be sure to allow sufficient time for change to take effect).</li> </ul>	<ul style="list-style-type: none"> <li>• Adjust coagulant dosage in accordance with plant guidelines, as required.</li> <li>• Adjust flash mixer/flocculator mixing intensity</li> <li>• Change frequency of sludge removal (increase or decrease).</li> <li>• Increase alkalinity by adding lime, caustic soda or soda ash.</li> </ul>
<b>2. In Coagulation Process Effluent Quality</b>		
Changes in: <ul style="list-style-type: none"> <li>• Turbidity</li> <li>• Alkalinity</li> <li>• pH</li> </ul>	<ul style="list-style-type: none"> <li>• Evaluate source water quality.</li> <li>• Perform jar tests as indicated</li> <li>• Verify process performance: (a) Coagulant feed rate(s), (b) Flash mixer operation.</li> <li>• Make appropriate process changes.</li> <li>• Verify response to process changes at appropriate time.</li> </ul>	<ul style="list-style-type: none"> <li>• Adjust coagulant dosage</li> <li>• Adjust flash mixer intensify (if possible).</li> <li>• Adjust alkalinity or pH.</li> </ul>
<b>3. In Flocculation Process Effluent Quality</b>		
Changes in <ul style="list-style-type: none"> <li>• Turbidity</li> <li>• Alkalinity</li> <li>• pH</li> </ul>	<ul style="list-style-type: none"> <li>• Evaluate overall process performance.</li> <li>• Perform jar tests as indicated</li> <li>• Verify performance of coagulation-flocculation process (see Chapter 4, “Coagulation and Flocculation”).</li> <li>• Make appropriate process changes.</li> <li>• Verify response to process changes at appropriate time.</li> </ul>	<ul style="list-style-type: none"> <li>• Adjust coagulant dosage</li> <li>• Adjust flash mixer/flocculator mixing intensity.</li> <li>• Adjust improperly working chemical feeder.</li> </ul>
<b>4. In Settling Basin</b>		
<ul style="list-style-type: none"> <li>• Floc Settling</li> <li>• Rising or Floating Sludge</li> </ul>	<ul style="list-style-type: none"> <li>• Observe floc settling characteristics: (a) Dispersion, (b) Size, (c) Settling rate</li> <li>• Evaluate overall process performance.</li> <li>• Perform jar tests if indicated: (a) Assess floc size and settling rate, (b) Assess quality of settled water (clarity and colour).</li> <li>• Make appropriate process changes.</li> <li>• Verify response to process changes at appropriate time.</li> </ul>	<ul style="list-style-type: none"> <li>• Adjust coagulant dosage.</li> <li>• Adjust flash mixer/flocculator mixing intensity.</li> <li>• Change frequency of sludge removal (increase or decrease).</li> <li>• Remove sludge from basin.</li> <li>• Repair broken sludge rakes.</li> </ul>
<b>5. In Settling Process Effluent Quality</b>		
Changes in: <ul style="list-style-type: none"> <li>• Turbidity</li> <li>• Colour</li> <li>• Total and soluble</li> </ul>	<ul style="list-style-type: none"> <li>• Check that throughput rate is steady</li> <li>• Check desludging arrangements</li> <li>• Evaluate overall process performance.</li> <li>• Perform jar test if indicated.</li> </ul>	<ul style="list-style-type: none"> <li>• Adjust coagulant dosage</li> <li>• Adjust flash mixer/flocculator mixing intensity.</li> <li>• Change frequency of sludge removal</li> </ul>
coagulant	<ul style="list-style-type: none"> <li>• Verify process performance: (a) Coagulation-flocculation process, (b) Floc settling characteristics</li> <li>• Make appropriate process changes.</li> <li>• Verify response to process changes at appropriate time.</li> </ul>	(increase or decrease).
<b>6. In Upflow Clarifier Process Effluent Quality</b>		
Changes in: <ul style="list-style-type: none"> <li>• Turbidity</li> <li>• Turbidity Caused by Sludge Blanket Coming to Top Due to Rainfall on Watershed</li> </ul>	<ul style="list-style-type: none"> <li>• As for Settling Process Effluent Quality Changes</li> <li>• Open main drain valve of clarifier.</li> </ul>	<ul style="list-style-type: none"> <li>• See 5 above.</li> <li>• Drop entire water level of clarifier to bring the sludge blanket down.</li> </ul>
<b>7. In Dissolved Air Flotation Effluent Quality</b>		
Changes in: <ul style="list-style-type: none"> <li>• Turbidity</li> </ul>	<ul style="list-style-type: none"> <li>• As for Settling Process Effluent Quality Changes</li> </ul>	<ul style="list-style-type: none"> <li>• See 5 above.</li> </ul>

## 6.3 LABORATORY TESTS

### 6.3.1 PROCESS CONTROL WATER QUALITY INDICATORS

In the operation of the coagulation-flocculation-clarification process, a variety of laboratory tests are required to be performed to monitor source water quality and to evaluate process performance. Process control water quality indicators of importance in the operation of the process include turbidity, alkalinity, chlorine demand, colour, pH, odour, appearance and temperature, which is best measured *in-situ*. Occasionally tests for dissolved oxygen and for permanganate value may be required.

### 6.3.2 SAMPLING PROCEDURES

Process water samples will be either grab samples obtained directly from a specific process monitoring location, or continuous samples which are pumped to the laboratory from various locations in the process (raw water, flash mixer effluent, flocculation and clarification basin effluents) as shown in Figure 13. In either case, it is important to emphasise that process samples must be a representative sample of actual conditions in the treatment plant. The accuracy and usefulness of laboratory analyses depend on the representative nature of the water samples. All sampling for laboratory analysis should be conducted according to best practice as set out in Standard Methods (APHA 1999).

The frequency of sampling for individual process control water quality indicators will vary, depending on the quality of the source water. Certain water quality indicators such as turbidity will be routinely monitored, while others such as alkalinity are monitored on a less frequent basis.

Process grab samples should be collected in clean plastic or glass containers and care should be used to avoid contamination of the sample, especially turbidity and odour samples.

Samples should be analysed as soon as possible after collection and as noted above in accordance with Standard Methods. Important water quality indicators such as turbidity, chlorine demand, colour, odour, pH and alkalinity can all change while waiting to be analysed. Temperature, as noted above is best measured *in-situ*.

### 6.3.3 SAMPLE ANALYSIS

Monitoring of certain process control water quality indicators, such as turbidity and pH, may be performed in larger works with the aid of automated analytical instruments such as turbidimeters and pH meters. Analysis of other process control water quality indicators, such as alkalinity and chlorine demand, may require wet chemistry procedures which are often performed by a chemist or laboratory technician, but some of them are readily carried out using colorimetric comparators.

One of the most important laboratory procedures performed in relation to the operation of the coagulation-flocculation-clarification process is the jar test procedure. This procedure is performed to establish the most effective type and optimum dose of chemical(s) to be used in the coagulation or flash-mixing process (Appendix B). Even the smallest treatment works using coagulation should be equipped to carry out this procedure. The minimum necessary equipment would comprise :-

- multiple stirrer for four reaction vessels,
- 4 No.1.5 litre beakers or similar sized clear glass containers,
- 4 No. test tubes clipped to a rack , to permit the simultaneous addition of chemical dose to all beakers,
- thermometer (to read from 5° to 25 °C - digital or glass),
- burette with stand or plastic graduated cylinders,
- set of turbidity bottle standards for 1,5,10,20 and 50 JTU prepared in accordance with Standard Methods,
- similar bottles to hold sample for comparison,
- litmus papers for pH determination (or comparator with discs for pH, colour and chlorine determinations),
- bottles of stock solutions of chemicals for use in tests,
- filter funnels, 60 mm and 110 mm in diameter,
- Whatman No. 4 filter papers,

- 10, 50 and 100 ml beakers and spare test tubes,
- test tube brushes and household detergent for cleaning glassware.

## 6.4 STARTUP AND SHUTDOWN PROCEDURES

### 6.4.1 CONDITIONS REQUIRING IMPLEMENTATION OF STARTUP/SHUTDOWN PROCEDURES

Startup or shutdown of the coagulation-flocculation-clarification process is NOT a routine operating procedure in most water treatment plants. These procedures generally happen when the plant is shut down for maintenance. In some rare instances, a shut-down may be required due to a major equipment failure or due to a serious pollution incident in the raw water supply.

### 6.4.2 IMPLEMENTATION OF STARTUP/SHUTDOWN PROCEDURES

Typical actions required in the startup or shutdown of the coagulation-flocculation-clarification process are outlined below. These procedures may have to be altered depending on the type of equipment in a specific plant and on the recommendations of the manufacturers of the equipment. Always follow the manufacturer's instructions.

### 6.4.3 STARTUP PROCEDURES

The procedures generally applicable to all plants are listed first and then, in turn, those for upflow/solids contact clarifiers, horizontal flow basins and dissolved air flotation plants.

#### 6.4.3.1 General Startup Procedures

1. Check the condition of all mechanical equipment for proper lubrication and operational status.
2. Make sure all chemical feeders are ready. There should be an adequate supply of chemicals available in the tanks and hoppers ready to be fed to the raw water.
3. Collect a sample of raw water and immediately run a jar test using fresh chemicals from the batch from which the supply of chemicals to the feeders was taken.

4. Determine the settings for the chemical feeders and set the feed rates on the equipment.
5. Open the inlet gate or valve to start the raw water flowing.
6. Start the selected chemical feed systems immediately.
  - a) Open valves to start feeding coagulant chemicals and dilution make-up water.
  - b) Start chemical feeders.
  - c) Adjust chemical feeders as necessary.

Note: do not allow untreated water to flow through the plant.

All raw water must be treated with appropriate coagulant. Water that has not been treated with a coagulant can flow through the filters without proper treatment (removal of colour and particulates) and into the distribution system.

#### 6.4.3.2 Procedures for Upflow/Solids Contact Tanks

After carrying out the procedures listed in Paragraph 6.4.3.1

7. Fill tank with water.

- a) Remove floating debris from tank water surface.
- b) Observe formation of the floc blanket in tank. It may be necessary to reduce the rate of flow through the tank initially to promote blanket formation or it may be possible to import surplus sludge from another works to seed the blanket. Ensure that automatic sludge bleed timers are turned off, or drawoff valves closed, until the blanket is satisfactorily established. The turbidity of the water coming from the tank should be checked and, if excessive, the water should be wasted if possible. If the rate of flow has been reduced initially it should be increased very gradually so as not to disrupt the blanket.

### 6.4.3.3 Procedures for Horizontal Flow Tanks

After carrying out the procedures listed in Paragraph 6.4.3.1

7. Turn on the flash mixer at the appropriate time. It may be necessary to wait until the tank or channel is full before turning on the flash mixer. Follow the manufacturer's instructions.
8. Start the sample pumps as soon as there is water at each sampling location. Allow sufficient flushing time before collecting any samples.
9. Start the flocculators as soon as the first basin is full of water. Be sure to follow the manufacturer's recommendations. If possible and appropriate, make any necessary adjustments in the speed.
10. Check operational status and mode of operation (manual or automatic) of equipment and physical facilities.
  - a) Check that basin drain valves are closed.
  - b) Check that basin isolation gates or stoplogs are removed.
  - c) Check that launder weir plates are set at equal elevations.
  - d) Check to ensure that all trash, debris and tools have been removed from basin.
11. Test sludge removal equipment.
  - (a) Check that mechanical equipment is properly lubricated and ready for operation.
  - (b) Observe operation of sludge removal equipment.
12. Fill clarification basin with water.
  - a) Observe proper depth of water in basin.
  - b) Remove floating debris from basin water surface.

### 6.4.3.4 Procedures for Dissolved Air Flotation Tanks

After carrying out the procedures listed in Paragraph 6.4.3.1 carry out the procedures listed at 7 to 9 in Paragraph 6.4.3.3 and fill the tank with water.

10. Start air compressor(s) for dissolved air flotation plant.
11. Start recycle water pump(s) when operating pressure is reached in the saturator vessel.

### 6.4.3.5 General Procedures for all Plants after Startup

1. Inspect mixing chamber and flocculation basins, where appropriate. Observe formation of floc and make any changes necessary.
2. Remove any debris floating on the water surface.
3. Perform water quality analyses and make process adjustments as necessary.
4. Calibrate chemical feeders.

## 6.4.4 SHUTDOWN PROCEDURES

It must be emphasised again that shutdown of the coagulation-flocculation-clarification process is not a routine or normal operation. It will, almost always, be part of the shutdown of the entire treatment plant, due to causes outside the Local Authority's control. If the shutdown is due to pollution in the source, the top priority must be to prevent the ingress of polluted water into any part of the treatment plant or its appurtenances, as set out in the Local Authority's Action Plan for the Protection of Water Supplies.

Site-specific procedures developed by the Local Authority for the emergency shutdown of the plant should be followed. Shutdown of the coagulation-flocculation-clarification process would include:-

1. Close raw water inlet gate or valve to flash-mix chamber, channel, upflow clarifier or DAF tank as appropriate.
2. Shut down the chemical feed systems.
  - a) Turn off chemical feeders
  - b) Shut off appropriate valves
  - c) Flush or clean chemical feed lines if necessary, paying particular attention to lime dosing plant.

3. Shut down flash mixer and flocculators, if used, as water leaves each process. Follow recommendations of the manufacturer.
4. Stop flow to horizontal flow clarification basin by closing valve.
5. Shut down sample pumps before water leaves each sampling location.
6. Turn off air compressor, recycle pump and sludge removal equipment in DAF tank.
  - (a) Shut off mechanical equipment and disconnect where appropriate.
  - (b) Check that valves are in proper position (either open or closed).
7. Lock out and tag electrical switches and equipment.
8. Dewater (drain) basins or tanks if necessary.
  - (a) Ensure that there is no danger of flotation of the empty basin due to high water table.
  - (b) Open basin drain valves. Waste any water that has not been properly treated.
9. Grease and lubricate all gears, sprockets, and mechanical moving parts which have been submerged immediately following dewatering. If this is not done, they can freeze up (seize up) in a few hours. Frozen parts will require long hours to repair and can result in equipment breakage.

## 7. RECORD KEEPING

### 7.1 IMPORTANCE OF RECORDKEEPING

The preparation and maintenance of accurate and complete plant operation records is one of the most important *administrative* functions of the water treatment plant operator. In large modern plants the bulk of the recordkeeping is done automatically by computer and the operator need only record events, not monitored by computer, such as deliveries of supplies, unusual meteorological conditions which might affect the works operation, his own visual observations and results of tests which he carries out. Accurate and complete records, especially if key items ( temperature, chemical dose in mg/l, pH, colour and alkalinity of both raw and finished water ) are graphed on a common time-base, are a great help to the operator in understanding the effects of changes, such as those due to seasonal factors on the treatment processes. Such records are vital in solving process problems. They may also be of great value should questions arise regarding the compliance, with prescribed standards of quality, of the water put into supply by the works. On a more mundane level, records of consumables usage are needed to reorder supplies.

The greater number of water treatment works are the smaller and less modern ones which rely on the operator for reading meters and gauges and writing down his observations. Such works are less likely to have equipment for continuous monitoring of pH and turbidity, so the operator is obliged to carry out a test in order to obtain the result to be recorded. Record entries should be neat, legible, reflect the date and time of an event and be initialed by the operator. A suitable record form for a small works is shown in Appendix B.

### 7.2 CHEMICAL STORES RECORDS

Chemical stores records are required for normal inventory control, as with any other stores, but also as a check on coagulant dosage rates. They serve to ensure that chemical reagents used in tests are not out of date. The complexity of the record system depends on the complexity of the treatment regime applied to the water. The simplest case is where only a single coagulant is

applied to water, which has sufficient alkalinity to coagulate successfully. A more usual case would be where alkali is applied to water in addition to a single coagulant. Some works have to treat water which varies so much that a choice of coagulants is necessary as well as polyelectrolytes. The chemical stores records will also have details of the disinfection and fluoridation chemicals, in addition to coagulation / flocculation chemicals.

### 7.3 JAR TEST RECORDS

The jar test is an attempt to duplicate in the laboratory what is occurring in the plant, in the relation between coagulant dosage, detention times, mixing conditions and settling conditions. The jar test is detailed in Appendix B and suitable forms on which to record the coagulants used and the test results, are included. The jar test is only an indication of what may be expected to occur in the treatment plant, and the actual out-turn in the plant as a result of the coagulant dose tested in the jar should be noted on the bottom of the form. Past jar test results are a most important resource for the operator to assist in estimating a suitable coagulant dose for a changed condition of the raw water - for example: if heavy rain has caused a doubling of turbidity, the operator can consult past jar test results to find the coagulant dose that was optimum under the nearest similar conditions previously and carry out a jar test using that coagulant dose in one jar and doses greater and less than it in other jars.

### 7.4 RECORDS OF MODIFICATIONS MADE TO TREATMENT

Any modification made to the current treatment regime, whether by way of variation of the coagulant dose, time of dosing or length or intensity of mixing should be fully recorded and documented. It has been suggested in Section 5.7 that the effects of any proposed modifications be checked on a pilot plant first. It is not possible, in the case of a sudden change in quality of the source water due to heavy rainfall say, to arrange pilot testing; the urgent necessity is to respond quickly to the quality change. As noted in the previous section, it is in cases such as this that the value of well-kept jar test records is most evident. As soon as the increase in turbidity is established,

a close approximation to the optimum coagulant dose can be deduced from the records and applied, even as jar testing is proceeding to experimentally determine the best treatment regime for the changed conditions. The jar test record and the operational record should be cross-referenced.

## 8. OPERATION AND MAINTENANCE

### 8.1 TYPES OF EQUIPMENT

In the operation of the coagulation-flocculation-clarification process, the operator will be exposed to a variety of mechanical, electrical and instrumentation equipment, which may include:

1. Mixers and flocculators
2. Chemical Feeders
3. Water quality monitors
4. Pumps
5. Valves
6. Flowmeters and gauges, and
7. Control systems.

In the coagulation-flocculation-clarification process itself, chemical feeders are of particular importance. Chemicals are normally fed at a fixed rate by liquid (solution) feed. This can be also accomplished by dry feed (volumetric or gravimetric). In liquid feed, a diluted solution of known concentration is prepared and fed directly into the water being treated. Liquid chemicals are fed through metering pumps and rotameters. Dry feeders deliver a measured quantity of dry chemical during a specified time interval. Volumetric feeders deliver a specific volume of chemical during a given time interval, while gravimetric feeders deliver a predetermined weight of chemical in a specific unit of time. Generally, volumetric feeders can deliver smaller daily quantities of chemicals than gravimetric feeders, but the performance variables are:

1. Volumetric feeders are simpler and of less expensive construction, and
2. Gravimetric feeders are usually more easily adapted for recording the actual quantities of chemicals fed and for automatic control. For this reason, gravimetric feeders are generally used in large treatment plants.

Water treatment plants should have duplicate chemical feeders. This will permit the operator to maintain full service while a chemical feeder is “off-line” for routine maintenance or major repair.

### 8.2 EQUIPMENT OPERATION

Before starting a piece of mechanical equipment such as a mixer or chemical feeder, be sure that the unit is properly lubricated and its operational status is known. Also be certain that no one is working on the equipment. Be sure all valves are in the proper position before starting chemical feeders.

After startup, always check for excessive noise and vibration, overheating, and leakage (water, lubricants, and chemicals). When in doubt about the performance of a piece of equipment, always refer to operation and maintenance instructions or the manufacturer’s technical manual.

Many equipment items such as valves and mixers are simple on/off devices with some provision for either speed or position adjustment. Other equipment items such as pumps and chemical feeders may require the use of special procedures for priming and calibration. Detailed operating and repair procedures are usually given in the plant operations and maintenance instructions for specific pieces of equipment.

During the course of normal operation, equipment should be periodically inspected for noise and vibration, leakage, overheating, or other signs of abnormal operation. Electric motors should always be kept free of dirt, moisture and obstructions to their ventilation openings.

### 8.3 PREVENTIVE MAINTENANCE PROCEDURES

Preventive maintenance programs are designed to ensure the continued satisfactory operation of treatment plant facilities by reducing the frequency of breakdown failures. This is accomplished by performing scheduled or routine maintenance on tanks, solution vessels and pipelines as well as valves, pumps, and other electrical and mechanical equipment items.

In the normal operation of the coagulation-flocculation-clarification process, routine maintenance functions must be performed as part of an overall preventive maintenance program. Typical functions include:



- Keeping electric motors free of dirt, moisture, and pests (spiders, flies, larvae, rodents and birds);
- Ensuring good ventilation (air circulation) in equipment work areas;
- Checking pumps and motors for leaks, unusual noise vibrations, or overheating;
- Maintaining proper lubrication and oil levels;
- Checking bearings for overheating and proper lubrication;
- Checking for proper valve operation, leakage or jamming;
- Checking automatic control systems for proper operation;
- Checking air/vacuum relief systems for proper functioning, dirt, and moisture;
- Checking chemical delivery lines for leakage (chemical delivery lines should be colour coded, placed in ducts and lengths minimised);
- Checking solution vessels and tanks for insoluble material and foreign matter and clearing residues monthly;
- Emptying clarifiers and other tanks annually, clearing deposits and algal growths, checking adequacy of protection to concrete faces against attack by chemically dosed waters, painting ironwork
- Checking calibration of dosing pumps as described in Appendix E using an apparatus similar to that shown in Figure 14;

- Verifying correct operation of coagulation-flocculation-clarification process by observation depending on the plant configuration;
- Inspecting operation of sludge removal facilities and nature of sludge removed.

Accurate recordkeeping is the most important element of any successful preventive maintenance program. These records provide operation and maintenance personnel with clues for determining the causes of equipment failures. They frequently can be used to forecast impending failures thus avoiding costly repairs.

#### 8.4 SAFETY CONSIDERATIONS

The coagulation/flocculation/clarification process involves the use of chemicals which are potentially dangerous (Appendix A). Bulk chemical liquid storage tanks should be surrounded by a bund wall of appropriate construction which has no outlets. This bunded area should be large enough to contain the contents of the tank plus an extra 10%. Any chemical leakage, rainwater or other liquid which collects inside the bund should be removed for disposal as advised by the Local Authority

There are other hazards involved for the plant operatives, which should be identified in the

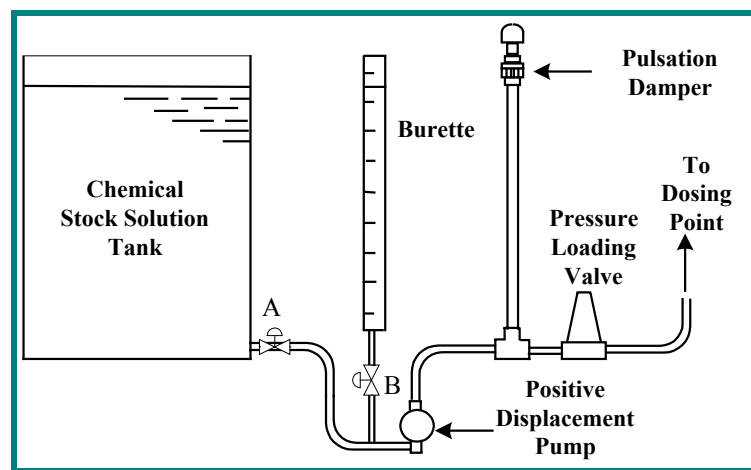

Figure 14: Dosing Pump Calibration

Safety Statement prepared for each treatment works, as required by the Safety, Health and Welfare at Work Act, 1989. Reference should be made to this Safety Statement by all persons involved in the operation and maintenance of the works. Some general guidance is set out below but the detailed information and procedures given in the Safety Statement should be followed in all cases. Where specific hazards are anticipated the

safety officer should be contacted and his instructions followed.

In the routine operation of the coagulation-flocculation-clarification process, the operator will be exposed to a number of potential hazards. Some of the potential hazards, which might be encountered in different areas and operations in a filter works are listed in Table 3.

**TABLE 3: POTENTIAL HAZARDS IN COAGULATION-FLOCCULATION-CLARIFICATION**

<b>Area / Operation</b>	<b>Potential Hazard</b>
Electrical Equipment	<ul style="list-style-type: none"> <li>• earthing of tools</li> <li>• locking out and tagging of switches and panels when servicing equipment</li> <li>• electric shock due to lying water or grounding on pipes</li> </ul>
Mechanical Equipment	<ul style="list-style-type: none"> <li>• removal of guards from rotating equipment</li> <li>• locking out and tagging of switches and panels when servicing pumps, automatic valves and other equipment</li> <li>• slippery surfaces due to lubricant spills</li> <li>• wearing of loose clothing in the vicinity of rotating equipment</li> </ul>
Open Water Surfaces	<ul style="list-style-type: none"> <li>• damage to handrails or failure to close safety chains</li> <li>• slippery surfaces on stairways or ladders due to spillages or use of unsuitable footwear</li> </ul>
Confined Space	<ul style="list-style-type: none"> <li>• Hazardous atmospheres (toxic or explosive gases, lack of oxygen)</li> <li>• Presence of dust</li> </ul>

The operator must realise that accidents do not just happen, they are caused. Therefore, strict and constant attention to safety procedures cannot be over-emphasised.

The operator should be familiar with general first aid practices such as mouth-to-mouth resuscitation, treatment of common physical injuries, and first aid for chemical exposure.

When working around electrical equipment, such as motors, mixers or flocculators, following the safety procedures listed below will help to avoid accidents or injury.

#### ELECTRICAL EQUIPMENT

1. Always shut off power, lock out and attach safety tag before working on electrical equipment, instruments, controls, wiring and all mechanical equipment driven by electric motors.
2. Avoid electrical shock by using protective gloves.
3. Use a voltmeter to test for “live” wires and equipment.
4. Check earths and avoid danger of being earthed in water or on pipes.
5. Earth all electrical tools, and
6. Ensure that work is carried in company of an operator/maintenance trades person.

#### MECHANICAL EQUIPMENT

1. Use protective guards on rotating equipment,
2. Do not wear loose clothing, worn gloves or long hair around rotating equipment, and
3. Clean up all lubricant (oil and grease) and polyelectrolyte spills.

#### OPEN WATER SURFACE STRUCTURES

1. Do not avoid or defeat protective devices such as handrails by removing them when they are in the way,
2. Close all openings when finished, and
3. Know the location of all life preservers and wear one when necessary.

#### VALVE AND PUMP VAULTS

1. Be sure all underground structures are free of hazardous atmospheres (toxic and explosive gases or insufficient oxygen) by using gas detectors,
2. Only work in well-ventilated structures, and
3. Ensure that you are accompanied by an operator/maintenance trades person.

#### LABORATORY WORK

Laboratory work may expose the operator to a number of different safety hazards. Care should be exercised in the handling of reagents and glassware. Use protective clothing (safety glasses and aprons) while performing wet chemical analyses, especially when handling dangerous chemicals such as acid or caustic solutions. Always perform lab tests in a well-ventilated space, and be familiar with the location and use of safety showers and eyewash facilities.

## 9. MANAGEMENT AND CONTROL

The primary function of a water treatment plant is to produce drinking water in a consistent and reliable manner in order to meet national drinking water quality standards. It is the responsibility of management to ensure that a satisfactory drinking water is produced at a reasonable cost. Chapter six of this manual discusses process control, chapter seven discuss record keeping while chapter eight outlines operation and maintenance requirements. These activities should not be seen in isolation and should be integrated to ensure that the treatment objectives are achieved. In order to integrate these activities and other activities, operators are advised to develop a management system.

The management system should address:

- organisation and responsibilities of personnel involved in the production of drinking water;
- operational control of the treatment plant;
- documentation and maintenance records of the treatment plant;
- audits of the plant;
- preventative maintenance;
- routine servicing;
- emergency response;
- equipment replacement; and
- monitoring programme and frequency of analysis.
- quantification of the environmental effects of the treatment plant;

### 9.1 MANAGEMENT SYSTEM AND AUDIT SCHEME

A schematic of a management and audit scheme is illustrated in Figure 15. The scheme should involve an initial review of activities, setting policy objectives, and putting in place a staff structure to implement the policy objectives. To

ensure that matters are progressing as planned an audit protocol is necessary. Any subsequent audit findings should be evaluated and amendments made to the management scheme as are deemed necessary.

### 9.2 INITIAL ENVIRONMENTAL REVIEW

The initial environmental review would:

- examine the current policy and practices at the plant;
- assess current performance; and
- make a list of recommendations including, objectives, plans and timescales.

This exercise should be repeated on at least an annual basis to assess the performance of the plant. The environmental review should assess the effectiveness of the management system and should include all staff involved in the production of drinking water. The review should have regard to the conclusions and recommendations of the annual EPA drinking water report and also to any advice provided by the Minister for the Environment and Local Government. The assessment should address:

- Revised goals and objectives;
- Performance against stated quality targets, production targets and yields;
- Potential improvement programmes; and
- Revisions to the systems to take cognisance of customer complaints;
- The outcome of previous audits;
- A review of resources, budgets and plant employed;

On an annual basis the operator should produce a report on the performance of the plant, the resources employed and the quality of the treated water.

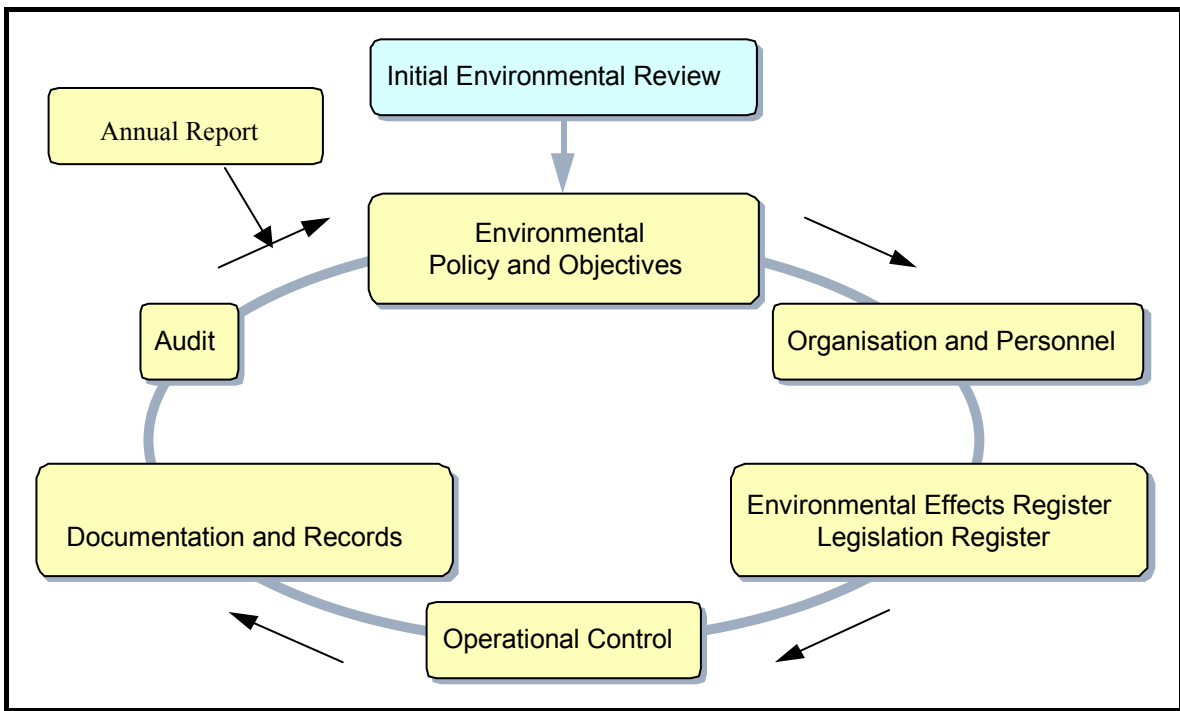

FIGURE 15: MANAGEMENT AND AUDIT SCHEMATIC

### 9.3 ENVIRONMENTAL POLICY AND OBJECTIVES

The environmental policy and objectives of the sanitary authority will establish the policy for the treatment plant. Policy objectives may include:

- Achievement of drinking water quality in compliance with European Communities (Drinking Water) Regulations, 2000 (S.I. No 439 of 2000);
- Continual improvement in performance;
- Optimising efficiency by maximising the use of resources;
- Disposal of any waste arsing consistent with national and EU legislation;
- Placing an emphasis on prevention of contamination rather than on detection; and
- Providing an ongoing training programme for staff.

### 9.4 ORGANISATION AND PERSONNEL

The organisational structure and responsibilities of each individual should be written down. Procedures for identifying training needs and allocation of sufficient resources to allow training needs to be fulfilled should be established. Appropriate training should be provided for all personnel. Records of all staff training and qualifications should be maintained.

### 9.5 ENVIRONMENTAL EFFECTS REGISTER

The environmental effects register will provide a basis for analysing and documenting the environmental effects of the water treatment plant and communicating these effects to relevant parties. These entries could include analysis of chemicals used in the process, noise from plant equipment, etc. together with information on sludge treatment, discharges from the plant.

### 9.6 OPERATIONAL CONTROL

The operational controls are a set of documented practices, procedures and systems to ensure that the activities of the plant operator which have an impact on the water treatment plant performance are carried out in accordance with specified procedures. Documented procedures relevant to drinking water may include:

- Chemical dosing and pH adjustment;

- Settlement tank operation;
- Filter operation;
- Chlorine dosing;
- Fluorine dosing; and
- Lime dosing.

### 9.7 DOCUMENTATION AND RECORDS

The documentation and records will cover a wide range of topics to provide the necessary evidence of compliance with the specified standards, i.e. the records required by:

- management; and
- legislation.

Specific records may include the dose rate of alum sulphate, polyelectolyte, fluoride, sulphuric acid and lime used in the production of drinking water. The records will assist the operator in demonstrating the extent to which the objectives and targets for the plant have been achieved.

### 9.8 THE AUDIT

The objective of an audit (either internal or external) is to evaluate the plant performance. This involves two factors:

- measurement of the standards achieved; and
- measurement of the effectiveness of the system or management process which have been used.

### 9.9 SECTOR REPORTS

The sector reports refer to the data to be submitted to the EPA to assist in producing the national reports on drinking water treatment as required.

### 9.10 ANNUAL REPORT

The annual report should describe the environmental performance of the plant and include compliance or otherwise with relevant legislation. The report should compare current environmental performance with previous years and should also set out a programme of work for the coming year.

## GLOSSARY

### **ABSORPTION**

The taking in or soaking up of one substance into the body of another by molecular or chemical action.

### **ACTIVATED CARBON**

Adsorptive particles or granules of carbon usually obtained by heating carbon. These particles or granules have a high capacity to selectively remove certain trace and soluble materials from water.

### **ADSORPTION**

The gathering of a gas, liquid, or dissolved substance on the surface or interface zone of another material.

### **AIR BINDING**

The clogging of a pipe, pump or filter due to the presence of air generally released from water. Air can prevent the passage of water through pipes or pumps or reduce their capacity.

### **ALGAE**

Algae are primitive organisms which are usually classified as plants. There are hundreds of different types, many of them microscopic, which may become visible by multiplication. When present to excess they cause trouble by blocking filters. Outbreaks vary with the region and the season.

### **ALKALINITY**

The capacity of water to neutralise acids. This capacity is caused by the water's content of carbonate, bicarbonate, hydroxide and some other ions including phosphate. Alkalinity is expressed as mg/l of equivalent calcium carbonate ( $\text{CaCO}_3$ ). Alkalinity is not the same as pH; water can have a high alkalinity without a high pH. Alkalinity is a measure of how much acid must be added to a liquid to lower its pH to 4.5.

### **APPARENT COLOUR**

Colour of the water due to substances suspended matter in the water as well as true colour q.v.

### **BASE METAL**

A metal (such as iron) which reacts with dilute hydrochloric acid to form hydrogen.

### **BATCH PROCESS**

A system in which a tank or reactor is filled, the contents treated and the tank or reactor is emptied before the cycle is repeated (as opposed to continuous process).

### **BUFFER SOLUTION**

A solution or liquid whose chemical composition neutralizes acids or bases without a great change in pH.

### **CATIONIC POLYELECTROLYTE (POLYMER)**

Polyelectrolytes are long-chain organic molecules with chemical groups attached along the length of the chain which become charged when the molecule is dissolved in water. In cationic polyelectrolytes the groups are positively charged.

### **CLARIFICATION**

The act of separating water from floc or other suspended matter by sedimentation in a horizontal flow tank, in a solids contact or upflow settlement tank or by dissolved air flotation

**COAGULANTS**

Chemicals that destabilize colloids and cause the fine colloidal particles to clump (floc) together into larger particles, which can be separated from the water by settlement or flotation.

**COAGULATION**

The clumping together of the fine colloidal particles into larger particles caused by the use of coagulants.

**COLLOIDS**

Between the upper limit of true solutions and the lower limit of suspensions lies the colloidal range. In colloidal dispersions, the particles :

- 1) cannot be removed from the water by means of ordinary filtration but can be separated by processes of *ultrafiltration* or of *dialysis* through the pores of animal or artificial membranes;
- 2) are not microscopically visible, but can be visualized as specks of light in the *ultramicroscope* and can be photographed by the electron microscope; and
- 3) will not settle under the action of gravity but can be caused to settle in a centrifuge or, better, in an ultracentrifuge.

Colloidal particles may either be aggregates or single large molecules, such as those of proteins or starches.

**COLOUR**

Many waters have a distinct colour, normally due to the presence of complex organic molecules derived from vegetable matter (such as peat, leaves, branches etc.), even after all turbidity has been removed. This is expressed in terms of the platinum-cobalt scale (Hazen units). Exceptionally, natural colour may be due to the presence of colloidal iron and/or manganese in a water (See apparent colour).

**CONVENTIONAL FILTRATION**

A method of treating water which consists of the addition of coagulant chemicals, flash mixing, coagulation-flocculation (not necessarily in separate tanks or basins), clarification by sedimentation/flotation and filtration. Also called complete treatment.

***CRYPTOSPORIDIUM***

The general descriptive term for the parasite *Cryptosporidium Parvum* (*C. Parvum*). *C. Parvum* is the only species of cryptosporidium known to cause disease in man. The environmentally resistant transmittable form of cryptosporidium excreted in the faeces of an infected host is called an Oocyst.

**DETENTION TIME**

The time required for water to pass through a tank or vessel at a given rate of flow.

**DIRECT FILTRATION**

A method of treating water which consists of the addition of coagulant chemicals, flash mixing, coagulation, minimal flocculation, and filtration. The flocculation facilities are occasionally omitted, but the physical-chemical reactions will occur to some extent. The sedimentation/flocculation process stage is omitted.

**FLASH MIXER**

A chamber in which coagulants are stirred into the raw water with considerable turbulence, induced either hydraulically or mechanically.

**FLOC**

Floc is the fine cloud of spongy particles that form in water to which a coagulant has been added. The particles are basically hydroxides, commonly of aluminum or iron. They accelerate the settlement of suspended particles by adhering to the particles and neutralizing such negative charges as may be present.

**FLOCCULATION**

Flocculation is the practice of gently stirring water in which floc has formed to induce the particles to coalesce and grow and thus settle more rapidly.



**FLOTATION TANK**

The attachment of tiny air bubbles induces the suspended matter to rise in a flotation tank rather than to sink in a settling tank, and removal of the solids is by skimming from the surface rather than by scraping from the bottom.

**GRAB SAMPLE**

A single sample of water collected at a particular place and time which represents the composition of the water only at that time and place.

**HEAD LOSS**

The head, pressure or energy lost by water flowing in a pipe or channel as a result of turbulence caused by the velocity of the flowing water and the roughness of the pipe, channel walls or restrictions caused by fittings. Water flowing in a pipe loses head, pressure or energy as a result of friction losses. The head loss through a filter is due to friction losses caused by material building up on the surface or in the interstices of the filter media.

**INORGANIC MATERIALS**

Chemical substances of mineral origin, such as sand, salt, iron

**INTERFACE**

The common boundary layer between two substances such as water and a solid (metal); or between two fluids such as water and gas (air); or between a liquid (water) and another liquid (oil).

**JAR TEST**

A laboratory procedure to estimate the most appropriate coagulant dose for a water to be treated or a change in dose rate consequent on a change in water quality. See Appendix B.

**LAUNDERS**

U-shaped discharge channels in settlement tanks / filters with overflow weir plates, normally with a series of small V-notches along the tops, to assure a uniform rate of flow.

**MOLECULAR WEIGHT**

The molecular weight of a compound in grams is the sum of the atomic weights of the elements in the compound.

**NTU**

Nephelometric Turbidity Unit, numerically equivalent to Jackson Turbidity Unit.

**OEL**

The Occupational Exposure Limit is the maximum permissible concentration of a chemical agent in the air at the workplace to which workers may be exposed, in relation to an 8-hour or a 15-minute reference period.

**ORGANIC**

Substances that come from animal or plant sources and which always contain carbon.

**PRECIPITATE**

- (1) The noun means an insoluble, finely divided substance which is a product of a chemical reaction within a liquid.
- (2) The verb means the separation from solution of an insoluble substance.

**REAGENT**

A pure chemical substance that is used to make new products or in chemical tests to measure, detect or examine other substances.

**REPRESENTATIVE SAMPLE**

A sample portion of matter that is as nearly identical in content and consistency as possible to that in the larger body of matter being sampled.

**SHORT - CIRCUITING**

A condition that may occur in tanks or basins when some of the water travels faster than the rest of the flowing water. This may have the undesirable result of water having less than the designed contact, reaction or settling time.

**SLUDGE**

The settleable (or floated) solids separated from water during processing.

**SLURRY**

A watery mixture or suspension of insoluble (not dissolved) matter; a thin watery mud or any substances resembling it (such as a grit slurry or a lime slurry)

**SPECIFIC GRAVITY**

- (1) Weight of a particle, substance, or chemical solution in relation to the weight of an equal volume of water. Water has a specific gravity of 1.000 at 4°C (or 39°F). Particulates in raw water may have a specific gravity of 1.005 to 2.5.
- (2) Weight of a particular gas in relation to an equal volume of air at the same temperature and pressure (air has a specific gravity of 1.0). Chlorine for example has a specific gravity of 2.5 as a gas.

**TRIHALOMETHANES (THMs)**

Suspected carcinogens derived from methane, CH<sub>4</sub>, in which halogen atoms (chlorine or bromine) are substituted for three of the hydrogen atoms and often formed during chlorination by reactions with natural organic materials in the water.

**TURBIDIMETER**

An instrument for measuring and comparing the turbidity of liquids by passing light through them and determining how much light is reflected by the particles in the liquid. The normal measuring range is 0 to 100 and is expressed as Nephelometric Turbidity Units (NTUs).

**TURBIDITY**

The cloudy appearance of water caused by the presence of suspended and colloidal matter.

**VISCOSITY**

A property of a fluid which resists efforts to change its shape or flow. The viscosity of water increases significantly as temperature decreases.

## APPENDIX A: CHEMICALS USED IN COAGULATION / FLOCCULATION / CLARIFICATION

Some of the chemicals most widely used in coagulation / flocculation / clarification have been referred to in the text of this manual. It is not intended to attempt to give an exhaustive list, as different manufacturers formulate products to their own design, particularly in the field of polyelectrolytes. A list of products in this field found, by the DOE Committee on New Chemicals and Materials of Construction for Use in Public Water Supply and Swimming Pools in the UK, to be unobjectionable on health grounds for the treatment of water for Public Supply covered six A4 pages. This list included products based on polyacrylamide, acrylamide / acrylate copolymers polyacrylic acid, starch, aluminum, polyquaternary resin, sodium alginate, tannin, quaternary ammonium polyelectrolytes and polyamide.

The Code of Practice (which is updated every two years) for the Safety, Health and Welfare at Work (Chemical Agents) Regulations, 1994, came into effect on 25 January 1995 and sets out “occupational exposure limits” for an exhaustive list of chemical agents. The Regulations (S.I. No. 445 of 1994) as amended stipulate that it shall be the duty of every employer to ensure that an occupational exposure limit shall not be exceeded.

The European Communities (Classification, Packaging, Labelling and Notification of Dangerous Substances) Regulations, 1994 (S.I. No. 77 of 1994) require that the packaging of all dangerous substances should carry a label showing sufficient information on the substance to enable a person to use the chemical safely. The Regulations also require that a **Safety Data Sheet** be provided to any professional or industrial user giving information on the substance under 16 headings. The **Safety Data Sheets** for all dangerous chemicals in use on the works should be kept near the place of use and the recommendations for health and safety contained in them should be familiar to anybody using the chemicals. Some generic details of the most widely used chemicals are given below, but for information on any specific point refer to the **Safety Data Sheet** provided by the supplier.

*Alum* is the common (and incorrect) name for *Aluminium Sulphate* also known as sulphate of alumina, and is probably the most widely used coagulant in water treatment. The classical chemical formula for aluminium sulphate is  $Al_2(SO_4)_3 \cdot 18H_2O$ , but as used in water treatment it contains varying amounts of water of crystallization. It is supplied in the form of slabs with  $21 \cdot H_2O$  and in granulated or kibbled form with  $14 \cdot H_2O$  water of crystallization. The chemical is readily soluble but the solution is corrosive to aluminium, steel and concrete so tanks of these materials need protective linings. The chemical is also available in liquid form. Its most effective range for coagulation is pH 5.5 - 8 and its reaction when added to water is with the natural or added alkalinity to form aluminium hydroxide  $Al_2(OH)_3$  (floc) according to the alkalinity present.

Aluminium sulphate should be treated as a weak acid. Avoid all unnecessary contact with it, as a matter of good working practice. Wear rubber or PVC boots, apron and overclothing as necessary depending on the condition of handling. The occupational exposure limit is 2 mg per cubic metre for an 8-hour reference period. The material is irritating to skin, eyes and nose and mouth by inhalation. Ingestion causes gastric

irritation, nausea and vomiting, if large doses are swallowed. Irrigation with cold water is recommended for affected skin and eye areas and the seeking of medical attention. Removal to fresh air, loosening of clothing and the seeking of medical attention is recommended for persons affected by inhalation. Immediate medical attention should be sought for a person who has ingested the chemical and vomiting should not be encouraged.

**Ferrous Sulphate** ( $\text{FeSO}_4 \cdot 7\text{H}_2\text{O}$ ), also called *copperas*, iron sulphate or sugar of iron is supplied in small lumps or as light -green crystals and is hygroscopic and tends to cake above  $20^\circ\text{C}$ . The chemical may clog dry-feeding equipment, so is best added as a solution. Ferrous sulphate alone is not widely used in the treatment of water supplies for domestic purposes but if so used, the pH value must be raised above 8.3 by addition of lime or caustic soda and steps must be taken to ensure that the water being treated contains sufficient dissolved oxygen for oxidation of the iron.

Ferrous sulphate, in conjunction with chlorine, has formerly been widely used in drinking water treatment as chlorinated copperas. The likelihood of the formation of trihalomethanes, by the action of the excess chlorine required to complete the chlorination reaction, has caused the use of this coagulant to be largely or entirely discontinued in the public water supply sphere.

**Ferric Chloride**, ( $\text{Fe Cl}_3$ ) is available in liquid form, in yellow-brown lumps as crystal ferric chloride  $\text{Fe Cl}_3 \cdot 6\text{H}_2\text{O}$  or as anhydrous ferric chloride in green-black powder form. The occupational exposure limit for iron salts (as Fe) is 1mg per cubic metre for an 8-hour reference period and 2mg per cubic metre for a 15-minute reference period. The solutions of iron salts are aggressive, acidic liquids, the chloride being more aggressive than the sulphate, corrosive to copper, copper alloys and ferrous metals. Special materials have to be used to line storage containers and for dosing equipment. As noted in Section 1.3 of the manual, alum treated water may be unacceptable to some users and in such cases coagulation using iron salts is an option. Even more skilled and close control of treatment is required to prevent iron remaining in solution than in the case of aluminium in solution in alum treated water.

**Lime** is probably the most widely used alkali in water treatment. It may occasionally be used as CaO (quicklime) but is normally supplied as  $\text{Ca}(\text{OH})_2$  (slaked or hydrated lime), in bulk tankers to larger works and in bags to smaller works. Lime may be slurry-fed or dry-fed. Lime slurry storage tanks must be continually agitated to maintain uniform consistency. Slurry strengths are normally less than 10% to avoid possible problems with accuracy of the chemical pumps or blockage in the lines. When lime dosing plant is taken out of use, say when a change of duty pump is made, the pump and feed lines should be emptied of all lime by rodding if necessary and flushed with clean water.

Bulk supplies of lime are pneumatically transferred to storage silos on large works, so there are no problems with lime dust until the powder is to be mixed in the slurry storage tanks, which are usually enclosed to avoid dust. Delivery and use of bags of slaked lime can give rise to severe dust problems if care is not taken. The occupational exposure standard is 5 mg per cubic metre for an 8-hour reference period.

**Soda Ash** is the common waterworks name for  $\text{Na}_2\text{CO}_3$ , anhydrous sodium carbonate, a white alkaline odourless crystalline powder. Sodium carbonate is strongly alkaline and forms caustic soda with hydrated lime in the presence of moisture. It reacts vigorously with acids to form carbon dioxide. Avoid all unnecessary contact with it, as a matter of good working practice. Wear protective clothing as necessary depending on the condition of handling. No occupational exposure limit has been set for this chemical. The material is irritating to eyes and nose and mouth by inhalation. Irrigation with cold water is recommended for affected eyes as and the seeking of medical attention. Removal to fresh air, loosening of clothing and the seeking of medical attention is recommended for persons affected by inhalation. Immediate medical attention should be sought for a person who has ingested the chemical, the person should be allowed to drink plenty of water and vomiting should not be encouraged.

**Sulphuric Acid** ( $\text{H}_2\text{SO}_4$ ), is a colourless oily liquid, available in various concentrations. It is used occasionally in water treatment to depress the pH of water. The occupational exposure limit is 1 mg per cubic metre for an 8-hour reference period. Avoid all unnecessary contact with it, as a matter of good working practice. *Sulphuric Acid must be diluted by very slowly adding the acid to water.* **Never** add water to the acid as violent sputtering will occur with danger of acid burns. Wear goggles or face shield, rubber or PVC boots, apron and overclothing as necessary depending on the condition of handling. The material causes severe burns to eyes and skin. Ingestion causes severe internal irritation and damage. Irrigation with cold water is recommended for affected skin and eye areas and the seeking of medical attention. Removal to fresh air, loosening of clothing and the seeking of medical attention is recommended for persons affected by inhalation. Immediate medical attention should be sought for a person who has ingested the chemical.

**Caustic Soda** (NaOH) is the common name for Sodium Hydroxide, a white alkaline odourless material supplied as flakes packed in drums. It is used, although not widely, in water treatment to raise the pH of water. The material reacts with various metals including aluminium and zinc in the presence of moisture to produce hydrogen. Avoid all unnecessary contact with caustic soda as a matter of good working practice. Wear goggles or face shield, gloves, rubber or PVC boots, apron and overclothing as necessary depending on the condition of handling. Caustic soda and its aqueous solutions are severely irritant and caustic on skin and mucous membranes. Its effect on the eyes can lead to blindness. Inhalation of the vapours, fumes or dust likewise has a caustic effect on the respiratory tract. The occupational exposure limit for caustic soda is 2 mg per cubic metre for a 15-minute reference period. Irrigation with cold water is recommended for affected skin and eye areas followed by rinsing with borax-boric acid buffer solution and the seeking of medical attention. Removal to fresh air, loosening of clothing and the seeking of medical attention is recommended for persons affected by inhalation. Immediate medical attention should be sought for a person who has ingested the chemical.

**Polyelectrolytes** are long-chain organic molecules with chemical groups attached along the length of the chain which become charged when the molecule is dissolved in water. These groups can be cationic ( + charge), anionic ( - charge), non-ionic (zero charge) or amphoteric ( + and - charges). Polyelectrolytes are widely used in water treatment as flocculant aids with iron or aluminium coagulants or sometimes as primary flocculants to

replace inorganic coagulants and reduce the mass of sludge produced. Some polyelectrolytes may contain a small proportion of acrylamide for which the occupational exposure limit is 0.3 mg per cubic metre for an 8-hour reference period. Polyelectrolytes are not acutely toxic but care should be taken to avoid swallowing, contact with the eyes or prolonged contact with the skin. Always consult the **Safety Data Sheet** for the product in use for details of any health hazards involved. Polyelectrolyte powder, dropped on a wet floor turns into a tough slippery jelly which is dangerous and difficult to clean up. Powder, if spilled, should be collected as dry material as far as possible before the area is washed liberally with (if possible) warm water. Polyelectrolyte solutions are not particularly corrosive but it should be noted that galvanised steel, natural rubber and copper alloys are most likely to be sensitive but some polyelectrolytes also attack mild and carbon steel and aluminium. It should be noted that some products approved for use in the treatment of water for public supply, which are mixtures of polyelectrolytes and metallic salts, could be assumed to be polyelectrolytes but have different health hazards and effects on containers.

## **APPENDIX B: TYPICAL OPERATING RECORD SHEET FOR A SMALL TREATMENT WORKS**

NAMED AUTHORITY

*Ballybeg* WATER TREATMENT PLANT

COAGULATION, FLOCCULATION & CLARIFICATION

Sheet No. : 311 Daily Operating Record

Source of Water : *Ballybeg River-Normal Winter Flow* Water Intake 17700

WATER QUALITY DATA										
Time of Sampling	Raw			Clarifd			Final			Raw
Water Sampled										
Temperature °C										
Colour (Hazen)										
pH										
Turbidity NTU										
Alkalinity mg/l CaCO <sub>3</sub>										
Hardness										
Conductivity										
Chlorine Residual										
Fluoride										
Total Coliforms /100ml										
Faecal Coliforms/100ml										

COAGULANTS and CHEMICALS

Signature *J. Smith*

Aluminium/Ferric Sulphate Pump No. \_\_\_\_\_ % Stroke \_\_\_\_\_ Dose \_\_\_\_\_ mg/l

Tank No. \_\_\_\_\_ in service. Density - °Twaddle \_\_\_\_\_

Tank No. \_\_\_\_\_ Filling / Filled at \_\_\_\_\_

Soda Ash / Lime Pump No. \_\_\_\_\_ % Stroke \_\_\_\_\_ Dose \_\_\_\_\_ mg/l

Tank No. \_\_\_\_\_ in service. Tank No. \_\_\_\_\_ Filling / Filled a

Polyelectrolytes Pump No. \_\_\_\_\_ % Stroke \_\_\_\_\_ Dose \_\_\_\_\_ mg/l



**NAMED AUTHORITY**  
**WATER TREATMENT PLANT**  
**COAGULATION, FLOCCULATION & CLARIFICATION**

Sheet No. : .....

**Daily Operating Record**

Source of Water :

Water Intake .....

WATER QUALITY DATA										
Time of Sampling										
Water Sampled	Raw	Clarifd	Final	Raw	Clarifd	Final	Raw	Clarifd	Final	Raw
Temperature °C										
Colour (Hazen)										
pH										
Turbidity NTU										
Alkalinity mg/l CaCO <sub>3</sub>										
Hardness										
Conductivity										
Chlorine Residual										
Fluoride										
Total Coliforms /100ml										
Faecal Coliforms/100ml										

**COAGULANTS and CHEMICALS**

Signature .....

Aluminium/Ferric Sulphate      Pump No. .... % Stroke ..... Dose ..... mg/l

Tank No. .... in service.      Density - °Twaddle .....

Tank No. .... Filling / Filled at .....

Soda Ash / Lime      Pump No. .... % Stroke ..... Dose ..... mg/l

Tank No. .... in service.      Tank No. .... Filling / Filled a

Polyelectrolytes      Pump No. .... % Stroke ..... Dose ..... mg/l



## APPENDIX C: JAR TEST DETAILS

The purpose of the jar test, or the laboratory coagulation test, is to determine the optimum chemical conditions in terms of coagulant dose and pH for treatment of the water concerned. It is probably the most important routine test carried out at a treatment works employing coagulation and flocculation as part of the treatment process. The results should be used for control of the treatment plant but not necessarily for prediction of plant operating rates, final turbidity and total ( as distinct from soluble ) coagulant levels. The minimum equipment necessary is listed in Section 6.3.3 of the Manual.

The principal piece of apparatus required for the test is a multiple stirrer unit for four or more reaction vessels as shown in Figure 2. This consists of a horizontal spindle, actuated from an electric motor by means of a belt and pulley system, driving vertical paddles in the reaction vessels. A speed selection system enables the paddles to be driven at either 20 rev / min or 200 rev / min. Test tubes or beakers should be clipped to a rack of suitable design to provide for simultaneous chemical addition to all vessels and a separate rack can be made up for each chemical to be added. In this way the time of addition of the various reagents can be controlled accurately. After coagulant addition the vessels in the rack should be rinsed quickly with distilled water and the rinsings added to the reaction vessels.

The reaction vessels should preferably be of a size capable of accommodating samples of one litre. Glass beakers of 1.5 litre capacity are available from laboratory suppliers but wide necked jam, coffee or battery jars of clear glass may be used instead. Cleanliness of all glassware is essential as the basis of the test is a comparison of the appearance of the water in the jars. Reaction vessels, beakers and test tubes should be washed in a solution of household detergent, using a test tube or other suitable brush, and rinsed three times in clean water before being allowed to drain and then stored in a dust free place.

Stock solutions or suspensions of coagulants, coagulant aids and alkalis should be made up to a strength such that 1 ml added to a litre of water will give a dose equivalent to 1, 5 or 10 mg/l. as is most suitable for the water being tested. 1 ml of a 0.1% solution added to 1 litre gives a dose of 1mg/l. Distilled or unchlorinated filtered water should be used to make the solutions / suspensions as should the chemicals in stock at the plant. It should be noted in preparing solutions of any chemical, that a 5% (w/w) solution means that 5 parts by weight of the chemical (e.g. 5g) is added to 95 parts of water also by weight (e.g.95g) and that a 5% (w/v) solution means that 5 parts by weight of the chemical (e.g. 5g) is added to 95 parts of water by volume (e.g.95ml). Percentages refer to the actual chemical e.g., aluminium sulphate, and not to the basic element (aluminium). All solutions should be clearly labelled, with the date of preparation noted, and bottles kept clean and well stoppered. It is important to shake all solutions, and more particularly suspensions, before measurement.

TABLE 4: STOCK SOLUTIONS FOR COAGULATION TESTS

Chemical	Concentration of Chemical	Prepare Fresh Stock Solution or Suspension After	Notes
$\text{Al}_2(\text{SO}_4)_3 \cdot 16\text{H}_2\text{O}$	1%	1 month	Renew if solution becomes opalescent
$\text{FeSO}_4 \cdot 7\text{H}_2\text{O}$	1%	1 week	Dilute 10 times immediately before use
Soluble starches	0.5%	2 days	Solution should be at least 1 day old. Dilute 10 times immediately before use
Polyacrylamide derivatives	0.5%	1 week	
$\text{H}_2\text{SO}_4$	0.1 N	3 months	
NaOH	0.1 N	1 month	
Fullers earth	0.5%	3 months	Shake well before use

The basic procedure in carrying out coagulation tests to study the effects of dose of coagulant chemicals is :-

- (i) a bulk raw water sample is obtained and mixed well;
- (ii) 1 litre samples are measured into the reaction vessels;
- (iii) rapid stirring (200 rev / min ) is applied for 1 minute;
- (iv) coagulant solution to give the desired range coagulant of doses is added to all vessels simultaneously;
- (v) rapid stirring is maintained for 1 minute;
- (vi) slow stirring (20 rev / min) is applied for 15 minutes, estimating flocculation time and final floc size using the Floc Comparator Chart - Figure 15 to assign the floc in each beaker to one of the categories A to G;
- (vii) settling is allowed for 30 minutes;
- (viii) supernatant samples are decanted and colour, turbidity and pH determined.

The best result will be the dose that has produced the most rapidly-settling floc in the shortest time. If the test has been carried out with a difference of say 10 mg/l of coagulant between each of the vessels, the test can be repeated, centred on the result just obtained and with differences of 2 or 3 mg/l of coagulant between vessels. The best floc will not

necessarily be the largest, since large flocs often settle slowly and are easily broken. The best flocculation is shown by coarse dense granular particles which, while settling down, show streaks of clear ( not dull or smoky ) water between individual particles. Where different combinations of chemicals give similar results, that with the lowest polyelectrolyte dose is to be preferred.

A complete record should be made of the test and kept for future reference including test number, the quantity of solution, the coagulant dose(s), the time to form and appearance of floc and its rate of settlement. If desired settled waters can be filtered by passing through Whatman No. 4 filter paper and tested for pH, colour and turbidity. They should be kept under observation for at least 24 hours in clear glass-stoppered bottles standing on a sheet of black paper in order to detect any signs of after-precipitation.

A slightly modified procedure is used if coagulant aid (polyelectrolyte or other) is used:

- (iv) primary coagulant solution is added to all vessels simultaneously;
- (v) rapid stirring is applied, usually for 1 minute;
- (vi) coagulant aid solution is added;
- (vii) rapid stirring is continued for 1 minute;
- (viii) slow stirring is applied for 15 minutes to allow flocculation ;
- (ix) settling, decanting and measurements are as above.

The jar test is an attempt to duplicate in the laboratory what is occurring in the plant, in the relation between coagulant dosage, detention times, mixing conditions and settling conditions. A suitable form on which to record the coagulants used and the test results, is shown in Fig. 15. The jar test is only an indication of what may be expected to occur in the treatment plant, and the actual out-turn in the plant as a result of the coagulant dose tested in the jar should be noted on the bottom of the form. Past jar test results are a most important resource for the operator to assist in estimating a suitable coagulant dose for a changed condition of the raw water - for example : if heavy rain has caused a doubling of turbidity, the operator can consult past jar test results to find the coagulant dose that was optimum under the nearest similar conditions previously and carry out a jar test using that coagulant dose in one jar and doses greater and less than it in other jars.

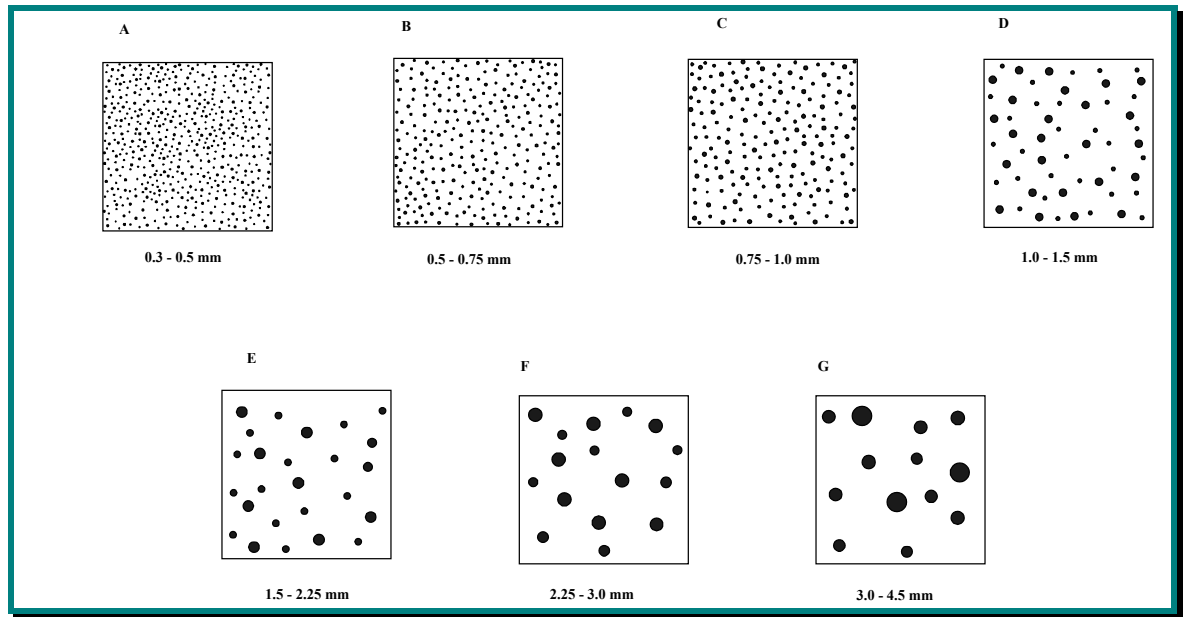

**Figure 16: Comparator for the Evaluation of Floc Size Index in Coagulation Tests**

		NAMED AUTHORITY																				
		<b>Ballebeg</b>		WATER TREATMENT PLANT																		
				COAGULATION, FLOCCULATION & CLARIFICATION																		
Sheet No. :	311	Jar Test Results														Date /Time:						
Water Source:	<i>Ballebeg River -</i>	Normal Winter Flow														Water Intake						
Operator	.....	Floc	Size	Index																		
Normal Laboratory Jar Testing Routine :-		Floc Diameter	Index Letter																			
1) Rapid stirring for 1 minute @ 200 rpm		Range in mm																				
2) Coagulant added to all jars		0.3 - 0.5	A																			
3) Rapid stirring continued for 1 minute.		0.5 - 0.75	B																			
4) Polyelectrolyte added (if used).		0.75 - 1.0	C																			
5) Rapid stirring for 1 minute extra.		1.0 - 1.5	D																			
6) Slow stirring for 15 minutes @ 20 rpm		1.5 - 2.25	E																			
7) Estimate flocculation time & floc size		2.25 - 3.0	F																			
8) Note time to filter 100 ml settled water through Whatman No 40 paper		3.0 - 4.5	G																			





## APPENDIX D: BATCH SOLUTION / SUSPENSION PREPARATION CURVES

The preparation of solutions of aluminium sulphate or other coagulants, coagulant aids or alkalis or suspensions of hydrated lime is an essential and routine part of the duties of a waterworks operator. While the basic action of bringing a known weight of chemical into solution / suspension in a known weight or volume of water to produce a solution / suspension of known strength for coagulation of the water is the same in any works, the operations to be carried out in a large modern works where chemicals are supplied in bulk, mechanically weighed and delivered to the solution tank, possibly under computer control, are very different to the operations at most works where the operator must personally weigh out the chemicals and ensure that they are mixed in the solution tank. There is obviously much greater need for the operator to be conscious of the implications for his personal safety and protection from chemicals, as well as the need for care and accuracy in the measurement of the chemicals, in this case than in the case where chemicals are weighed and dissolved by remote control.

### Chemical Compounds

Most natural substances are **compounds** of two or more **elements** joined by chemical bonds. Only a few elements, such as the noble gases, argon, neon etc., exist as individual **atoms**; most atoms are joined by chemical bonds to other atoms even in a **molecule** of the one element. Elemental chlorine is  $\text{Cl}_2$ , where Cl is the symbol for chlorine. Most symbols are derived from the initial or early letters of the name of the substance, thus Al is aluminium, O is oxygen, S is sulphur but a few symbols of interest in water treatment are derived from the initial of the Latin name of the substance including Fe (iron) Ferrum, K (potassium) Kalium, Na (sodium) Natrium and Cu (copper) Cuprum. The **chemical formula** of a compound is a description in symbols of its composition, thus water is  $\text{H}_2\text{O}$  and has two atoms of hydrogen combined with one of oxygen while sulphuric acid is  $\text{H}_2\text{SO}_4$  and has two atoms of hydrogen combined with one of sulphur and four of oxygen. The symbols  $\text{SO}_4$  represent the **sulphate radical** which occurs in many chemicals of interest in water treatment including aluminium sulphate  $\text{Al}_2(\text{SO}_4)_3 \cdot x\text{H}_2\text{O}$ , where  $x$  represents the number of molecules of **water of crystallization** in the particular form of the chemical concerned. In order to calculate the weight of aluminium sulphate to be added to water as coagulant, it is necessary to know the weight of the water of crystallization associated with it. The **atomic mass** or **weight** of the of the elements involved must be known, to make this calculation. Tables of the atomic mass of all elements are given in books on chemistry but only a limited number are of interest in water treatment :-

#### Atomic Mass of Elements for Water Treatment

Element	Symbol	Atomic Mass
Aluminium	Al	26.98
Calcium	Ca	40.08
Carbon	C	12.011
Chlorine	Cl	35.45

Fluorine	F	19.00
Hydrogen	H	1.008
Iron	Fe	55.85
Manganese	Mn	54.94
Nitrogen	N	14.007
Oxygen	O	15.999
Potassium	K	39.10
Sodium	Na	23.00
Sulphur	S	32.06

For waterworks purposes it is sufficient to round off the atomic mass (weight) at three significant figures and use 27.0 for aluminium, 40.0 for calcium, 12.0 for carbon, 35.5 for chlorine etc.

### Preparation of Solutions of Aluminium Sulphate (Alum)

Aluminium Sulphate or Alum, as noted before, is probably the most widely used coagulant. It is available in solid form as slabs and also in granulated or kibbled form with varying amounts of water of crystallization as well as in liquid form containing various concentrations of the chemical. Liquid aluminium sulphate at 36% concentration would be suitable for use, as supplied, for a works with throughputs from 100,000 to 1,000m<sup>3</sup>/day, assuming a dose rate of 50 mg/l aluminium sulphate. The 100,000m<sup>3</sup>/day works throughput is 4166 m<sup>3</sup>/hr, the dose rate per m<sup>3</sup> is 50g and the total input of aluminium sulphate / hr is 208,300g or 208.3 kg. The 36% solution has 360g of aluminium sulphate / litre so some 578.6 l/hr must be injected. For the 1,000m<sup>3</sup>/day works 5.79 l/hr must be injected. The volume of liquid aluminium sulphate at 36% concentration to be injected for a works throughput of 100m<sup>3</sup>/day (0.58l/hr), again assuming a dose rate of 50 mg/l, would be approaching the lower limit of capacity of the normal range of injection pumps.

Liquid aluminium sulphate is more commonly supplied at 8% concentration. This would be suitable for use, as supplied for a works throughput of 100m<sup>3</sup>/day. The 100m<sup>3</sup>/day works throughput is 4.2 m<sup>3</sup>/hr and, assuming the dose rate per m<sup>3</sup> is 50g, the total input of aluminium sulphate / hr is 210g. The 8% solution has 80g of aluminium sulphate / litre so some 2.63 l/hr must be injected. Correspondingly for a 1,000m<sup>3</sup>/day works 26.25 l/hr must be injected.

Solid aluminium sulphate must be dissolved and in order to know the strength of the solution prepared, the weight of aluminium sulphate, excluding water of hydration must be known. The usual chemical formula for aluminium sulphate is Al<sub>2</sub>(SO<sub>4</sub>)<sub>3</sub>.18H<sub>2</sub>O and, referring to the table of Atomic Mass, the weight of a molecule of the chemical is :- 2(27) + 3(32 + 4 x 16) + 18 (2 x 1 + 16) = 666 . The water of hydration accounts for 324 of this total so that the material is 51.4% Al<sub>2</sub>(SO<sub>4</sub>)<sub>3</sub>. { It should be noted that, for historical reasons, aluminium sulphate is sold commercially by the percentage of aluminium oxide (Al<sub>2</sub>O<sub>3</sub>) which it contains. This must not be confused with the percentage of Al<sub>2</sub>(SO<sub>4</sub>)<sub>3</sub> calculated above.} Preparation of a 5% solution of aluminium sulphate involves adding 5 kg of Al<sub>2</sub>(SO<sub>4</sub>)<sub>3</sub> to 95 kg of water (or 95 litres of water). If Al<sub>2</sub>(SO<sub>4</sub>)<sub>3</sub>.18H<sub>2</sub>O is the material being used, it is necessary to add 9.73 kg to make the 5% solution, on account of the water of crystallization in the material. Figure 16 can be used to read off the weights of aluminium sulphate, with 18 or 14 molecules of water of crystallization, to be added to the

volume of water in the solution vessel to prepare 5% and 10% solutions of the chemical. A solution preparation curve for other percentages or grades of aluminium sulphate can be made by similar calculations to those shown above.

### Preparation of Solutions of Iron Salts (Ferrous and Ferric Sulphate and Chloride)

Ferrous Sulphate (also called copperas, iron sulphate or sugar of iron) has the chemical formula  $\text{FeSO}_4 \cdot 7\text{H}_2\text{O}$  and is available commercially in small broken lumps or in a purer condition as light green crystals, similar in size to granulated sugar. As noted in Section 2.5 of the manual, this chemical is rarely used alone in treatment of water for public supply because of the very high pH needed for its reaction, unless the lime softening process is employed.

Ferric Sulphate ( $\text{Fe}_2(\text{SO}_4)_3 \cdot 9\text{H}_2\text{O}$ ) is a red-brown powder, which is difficult to dissolve, but is also supplied as a liquor containing up to 40% w/w and has advantages in treating certain waters. Ferric Chloride ( $\text{FeCl}_3$ ) is supplied as a liquor containing up to 40% w/w, as crystal ferric chloride with 6 molecules of water of crystallization or as anhydrous ferric chloride. It is extremely corrosive and difficult to handle, store and apply but again has advantages in treating certain waters. Both the above chemicals were formerly produced by the chlorination of a ferrous sulphate solution to produce *Chlorinated Copperas*, as noted in Section 2.1 of the manual. The likelihood of the formation of trihalomethanes (THM), by the action of the excess chlorine required to complete the chlorination reaction, has caused the use of this coagulant to be largely or entirely discontinued in the public water supply sphere as noted above. Ferrous Sulphate is soluble in water to the extent of 282 grammes per litre at  $0^\circ\text{C}$ , increasing to 331 grammes per litre at  $10^\circ\text{C}$ , 391 at  $20^\circ\text{C}$  and 455 at  $30^\circ\text{C}$  but as noted in the text is not normally used in water treatment.

Ferric Sulphate  $\text{Fe}_2(\text{SO}_4)_3 \cdot 9\text{H}_2\text{O}$  is soluble in 2 - 4 parts of cold water. Referring to the table of Atomic Mass, the weight of a molecule of the chemical is 562. The water of hydration accounts for 162 of this total so that the material is 71.17%  $\text{Fe}_2(\text{SO}_4)_3$ . Preparation of a 10% solution of ferric sulphate involves adding 10 kg of  $\text{Fe}_2(\text{SO}_4)_3$  to 90 kg of water (or 90 litres of water). If  $\text{Fe}_2(\text{SO}_4)_3 \cdot 9\text{H}_2\text{O}$  is the material being used, it is necessary to add 14.05 kg to make the 10% solution, on account of the water of crystallization in the material or 15.61 kg to make the 100 litres of the solution.

Ferric Chloride is available commercially as a 35% to 45% solution and can be diluted as required. Crystal Ferric Chloride  $\text{FeCl}_3 \cdot 6\text{H}_2\text{O}$  is readily soluble to the extent of some 480 grammes per litre at  $30^\circ\text{C}$ . Referring to the table of Atomic Mass, the weight of a molecule of the chemical is 270.5. The water of hydration accounts for 108 of this total so that the material is 60.07%  $\text{FeCl}_3$ . Preparation of a 10% solution of ferric chloride involves adding 10 kg of  $\text{FeCl}_3$  to 90 kg of water (or 90 litres of water). If  $\text{FeCl}_3 \cdot 6\text{H}_2\text{O}$  is the material being used, it is necessary to add 16.66 kg to make the 10% solution, on account of the water of crystallization in the material or 18.51 kg to make the 100 litres of the solution. If anhydrous Ferric Chloride  $\text{FeCl}_3$  is used 10 kg in 90 litres gives a 10% solution.

Figure 17 can be used to read off the weights of ferric sulphate and ferric chloride in its various forms to be added to the volume of water in the solution vessel to prepare 5% or 10% solutions of the chemicals.

### **Preparation of Solutions of Sodium Carbonate ( Soda Ash )**

Sodium Carbonate ( $\text{Na}_2\text{CO}_3 \cdot 10\text{H}_2\text{O}$ ) may be used to increase alkalinity instead of lime, especially in smaller works, because it is easier to handle and apply even though it may be more expensive to purchase. Sodium carbonate is soluble in water to the extent of 250 grammes per litre at  $0^\circ\text{C}$ , increasing to 305 grammes per litre at  $10^\circ\text{C}$ , 395 at  $20^\circ\text{C}$  and 568 at  $30^\circ\text{C}$ . Referring to the table of Atomic Mass, the weight of a molecule of the chemical is 286.1. The water of hydration accounts for 180 of this total so that the material is 37.1%  $\text{Na}_2\text{CO}_3$ . Preparation of a 10% solution of sodium carbonate involves adding 10 kg of  $\text{Na}_2\text{CO}_3$  to 90 kg of water (or 90 litres of water). If  $\text{Na}_2\text{CO}_3 \cdot 10\text{H}_2\text{O}$  is the material being used, it is necessary to add 26.95 kg to make the 10% solution, on account of the water of crystallization in the material or 29.95 kg to make the 100 litres of the solution. Figure 18 can be used to read off the weights of sodium carbonate to be added to the volume of water in the solution vessel to prepare a 10% solution of the chemical. Where other percentages or grades of chemicals are used a solution preparation curve can be made by similar calculations to those shown above.

### **Preparation of Suspensions / Solutions of Lime**

Lime, used in water treatment in this country, is normally in the form of Slaked or Hydrated Lime ( $\text{Ca}(\text{OH})_2$ ), chemically calcium hydroxide, although quicklime ( $\text{CaO}$ ) chemically calcium oxide, which must be slaked before application, has been used. Calcium hydroxide is only slightly soluble in water, to the extent of 1.85 grammes per litre at  $0^\circ\text{C}$ , decreasing to 1.65 grammes per litre at  $20^\circ\text{C}$ . Lime solutions are referred to as Milk of Lime, but lime is normally dosed as a suspension in supersaturated lime water. The suspension of lime tends to clog pumps and pipelines and constant attention is necessary to maintain correct dosage. Treatment of the suspension with sodium hexametaphosphate ( Calgon ) helps to alleviate the clogging problem. A mixing tank, with cover to prevent spread of lime dust and equipped with an agitator/stirrer to prevent settlement is needed. A 10% suspension of lime is formed by adding 10 kg of hydrated lime to 90 kg (litres) of water. About 150g of the hydrated lime will dissolve, depending on the temperature.

### **Preparation of Solutions of Polyelectrolytes**

The effectiveness and maximum storage life of polyelectrolyte solutions are affected by the quality of the make-up water. Polyelectrolyte molecules when in solution in a hard water tend to be less effective. Storage of solution will cause an initial improvement in effectiveness as the polymer chains uncurl, followed by a deterioration on prolonged storage. The deterioration is most rapid in hard water, and also with high molecular weight and low charge density polyelectrolytes. Starch polyelectrolytes even at high concentrations, degrade sooner than synthetic materials. Powdered polyelectrolytes can normally be stored for 12 months and in many cases longer. These products should be stored in a dry atmosphere. Undiluted liquid polyelectrolyte solutions and emulsions will usually have a shelf life of between 4 and 12 months. It is important to protect liquid products from frost. Stock solutions of 0.5% strength can usually be stored for two to three days but the working solutions of 0.05 to 0.1% should be prepared every day. It will be found convenient to make up the solution at the strength required for dosing, where less than  $10\text{m}^3$  /day of polyelectrolyte solution is used. If there is a stock tank holding one day's supply, this can be replenished as required by batches of solution prepared by hand.

With larger usage, preparation of stock solution at 5 to 10 times dosing strength, which can be diluted in batches as required or dosed into transport water and diluted in the pipe to the dosing point, will probably be more convenient. A proprietary automatic dissolving plant would be required where more than 10 kg/day of powder polyelectrolyte is being used. A cylindrical tank, with working depth just greater than its diameter, equipped with an agitator/stirrer to prevent powder grains settling on the tank floor while they dissolve and a baffle to prevent mass rotation of the tank contents, is the best choice of mixing tank. Where powder or bead grade polyelectrolyte is being used, the required amount should be weighed out, the stirrer in the mixing tank started, and the polyelectrolyte must be sprinkled into the water in such a way that the powder particles are wetted individually. If the powder lands on the water in 'clumps', the outside particles will form a dense jelly with dry powder inside. Even after several hours stirring such clumps may still be present. They may have become transparent and so invisible, but they can still interfere with the valves of dosing pumps. A good mixing technique, if the amount of powder per mix is less than, say 500g, is to put a finger over the end of the water hose to make the water form a fan, and sprinkle the powder slowly on this. The lighting should be good enough to let the operator see if any lumps are being made. The water spray must deliver directly to the water surface in the tank as if it impinges on the stirrer shaft or tank side the polyelectrolyte may turn to jelly. Where the amount of powder per mix is more than, say 500g, a proprietary disperser should be used to disperse the powder into the water.

The chemical formula for a polyelectrolyte is not often known and is not relevant to the preparation of solutions. The solution to be made is a concentration of the material as supplied. The preparation of a 1% solution of a given powder polyelectrolyte involves dispersing and mixing 1 kg of powder in 99 kg (99 litres) of water. Liquid polyelectrolytes, as supplied, contain a stated percentage of polymer. Adding an equal volume of water to the liquid halves the concentration of polymer in the resulting solution, adding three parts of water results in a solution with a quarter of the concentration of polymer in the liquid polyelectrolyte as supplied and adding nine parts of water results in a solution with a tenth of the concentration of polymer in the liquid polyelectrolyte as supplied

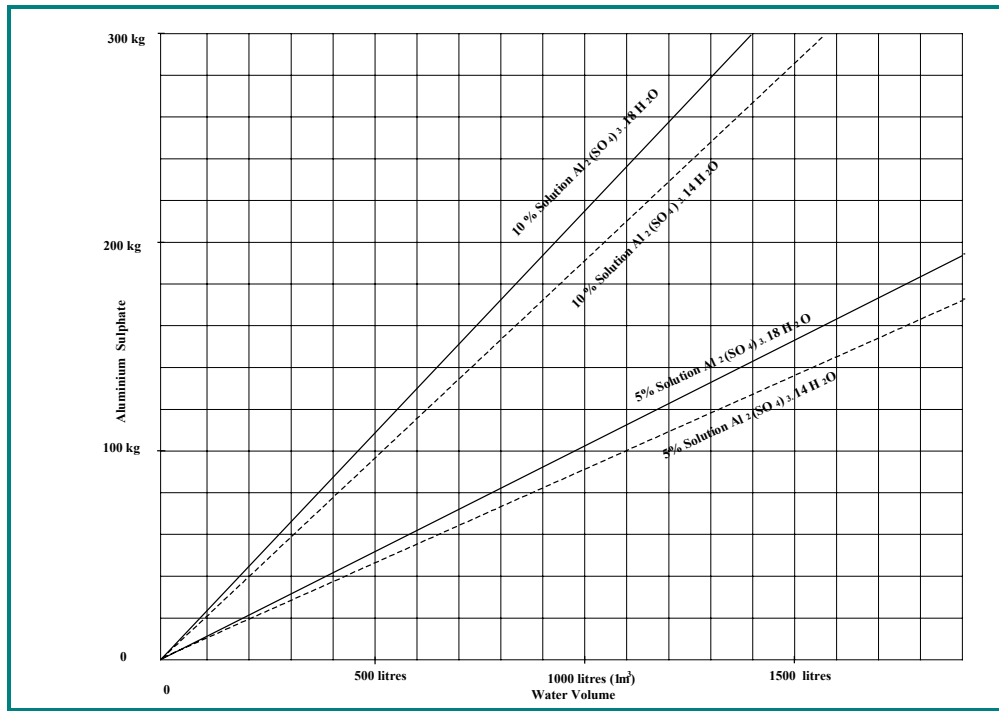

Figure 17: Batch Solution Preparation Curve for Aluminium Sulphate

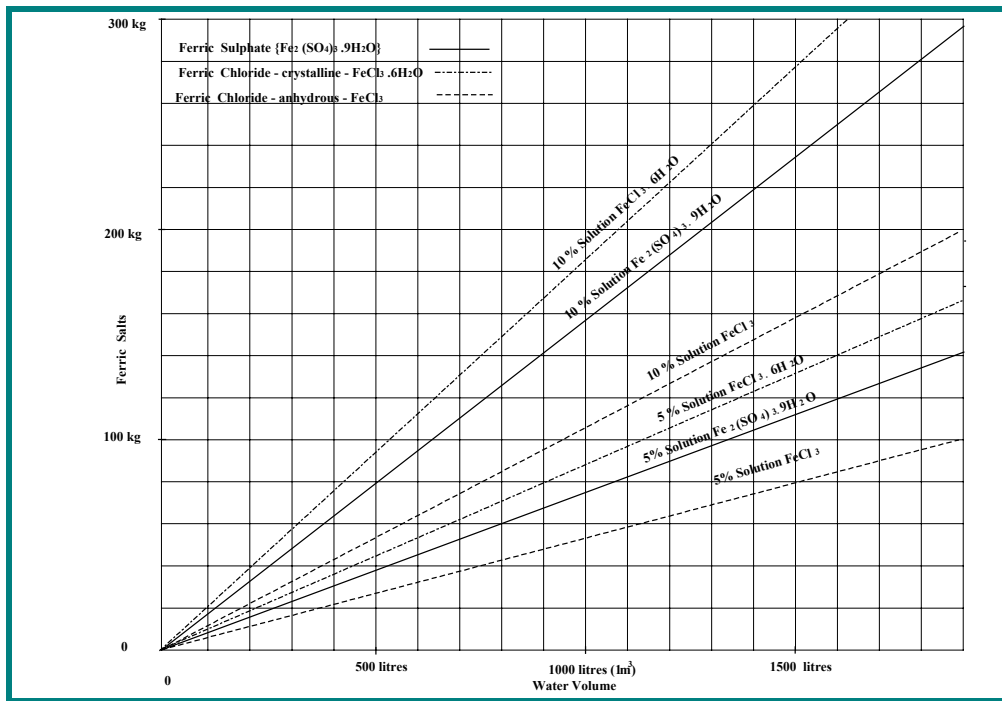
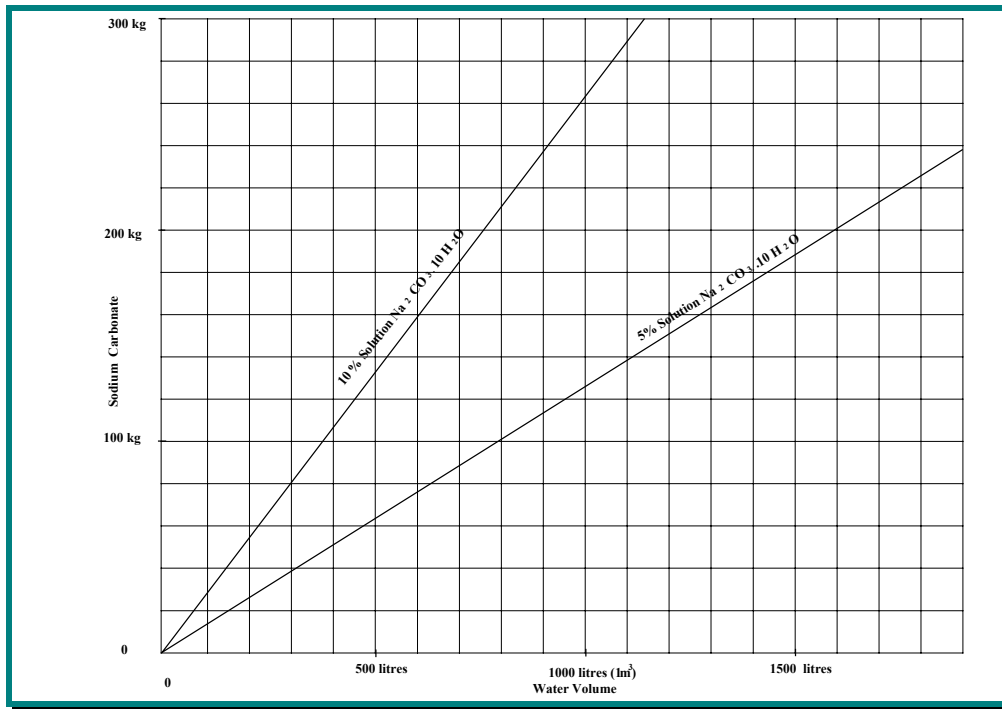

FIGURE 18: BATCH SOLUTION PREPARATION CURVES FOR FERRIC SALTS



**FIGURE 19: BATCH SOLUTION PREPARATION CURVES FOR SODIUM CARBONATE**





## APPENDIX E: ADJUSTMENT AND CALIBRATION OF CHEMICAL FEEDERS

Feeding of chemical coagulants, coagulant aids and all other chemicals in Water Treatment, with the exception of gaseous chlorine, is normally effected by diaphragm pumps. Where a pump has to deliver the chemical against high head a plunger is used instead of the diaphragm. Dry chemical feeders are rarely used and never on smaller works.

The principle of operation of both diaphragm and plunger pumps, generally, is that the rotary motion of the prime mover, usually an electric motor, is transformed by means of a cam arrangement to a reciprocating motion. This motion, when transmitted to the diaphragm or plunger, forces a known volume of liquid from the pump chamber. The reciprocating action may also be generated by means of a solenoid, which is energised and de-energised by an integral timer.

The pump capacity in litres per hour at maximum stroke is fixed by the manufacturers. The pump discharge is varied by adjustment of the stroke length. This adjustment is made manually by means of a handwheel, which indicates the percentage of maximum stroke selected. The adjustment may be automated to vary the stroke length in step with the flow through a meter.

### Dosing Pump Adjustment

The importance of dosing the correct amount of coagulants and coagulant aids to water has been emphasised previously. The preparation of the correct strength of batch solution of chemicals as detailed in Appendix C is the first requirement. The delivery of the proper amount of the solution is the second requirement. This involves selection of the correct stroke setting on the coagulant feed pump. The process can best be illustrated by an example: -

A Treatment Works has a throughput of 480 m<sup>3</sup> per day pumped at a constant rate of 20 m<sup>3</sup> per hour. The coagulant in use is aluminium sulphate and a 5% batch solution has been prepared. The optimum alum dose for the water has been found by jar testing as 20 mg/l. The coagulant feed pump delivers 20 litres/hour at maximum stroke setting against the head involved in this instance.

The water throughput rate is 20 m<sup>3</sup> per hour.

The required dose rate is 20 mg/l = 20 g/m<sup>3</sup>.

Therefore the total input of alum required is : -

$$20 \text{ g/m}^3 \times 20 \text{ m}^3/\text{h} = 400\text{g/h} = 0.4 \text{ kg/h}$$

The 5% batch solution contains 0.05 kg/l alum. The volume of batch solution required to deliver 0.4 kg of alum is  $0.4 / 0.05 = 8$  litres.

The coagulant feed pump delivers 20 l/h at maximum stroke; to deliver 8 l/h the stroke should be set at  $8 / 20 = 40\%$  of maximum.

### Dosing Pump Calibration

It is important to check regularly that volume of coagulant indicated by the dosing pump stroke setting is in fact being delivered to the water supply. This can be done by fitting a suitable valve controlled calibration chamber on the suction side of the dosing pump similar to the arrangement shown on Figure 19.

The burette or other vessel should be calibrated in sensible intervals of 10, 20 or 50 ml as appropriate to the maximum dosing rate. In normal operation both valves A and B, which should preferably be quarter turn cocks with A spring loaded to the open position, are open and the burette acts as a sight gauge of the contents of the chemical tank. The pump calibration check is carried out by closing valve A as the stopwatch is started and noting the volume withdrawn from the burette in the test period. The pump rate per hour can then be calculated. For instance in checking the 40% pump setting on the pump in the previous paragraph for a period of 90 seconds the liquid level in the burette dropped almost 4 of the 50 ml units - say 199 ml. This represents an hourly rate of  $40 \times 199$  ml or 7.96 litres which is within 0.5% of the desired rate.

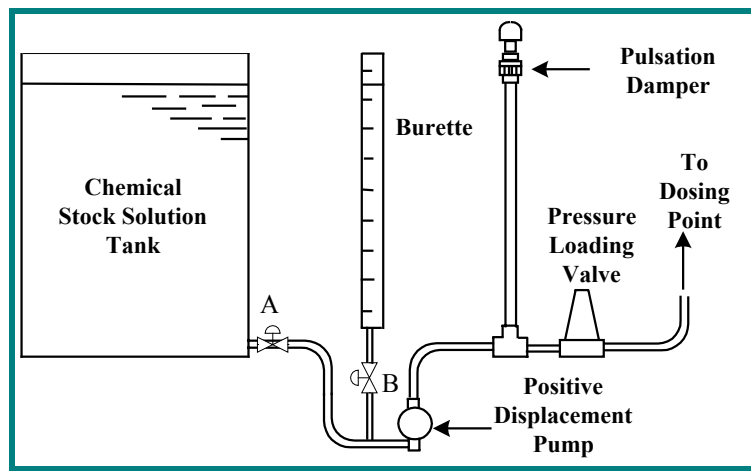

FIGURE 20: DOSING CALIBRATION PUMP

## REFERENCES & READING LIST

1. APHA - Standard Methods for the Examination of Water and Wastewater 20th Edition (March 1999).
2. US EPA *Water Treatment Manual*
3. Smethurst, George. ( Second Edition, 1990) *Basic Water Treatment* Thomas Telford Ltd., London.
4. Twort, A.C., Law, F. M., Crowley, F. W., and Ratanayaka, D.D., ( Fourth Edition, 1994 ). *Water Supply*. Edward Arnold, London.
5. Calcutt, T. (1978) *Water Treatment Changes to Minimise Discoloured Water Problems* in Papers and Proceedings of WRC Conference - Maintenance of Water Quality and Pipeline Integrity. Water Research Centre, Medmenham.
6. Lockyear, C.F., Jackson, P.J. and Warden, J.H.(1983 ) *Polyelectrolyte Users' Manual* Technical Report TR 184, Water Research Centre, Medmenham.
7. Severn Trent Water Limited (1992) *Clarification and Softening Processes*.
8. Rees, A. J., Rodman, D.J., and Zabel, T. F., (1979 ) *Water Clarification by Flotation* Technical Report TR 114, Water Research Centre, Medmenham.
9. *European Communities ( Quality of Water Intended for Human Consumption ) Regulations 1988*. ( S.I. No 84 of 1988 ).
10. *European Communities ( Drinking Water ) Regulations 2000*. ( S.I. No 439 of 2000
11. *Safety, Health and Welfare at Work Act, 1989* ( No. 7 of 1989 ). Stationery Office, Dublin.
12. *Safety, Health and Welfare at Work ( General Application ) Regulations, 1993* (S.I. No. 44 of 1993 ). Stationery Office, Dublin.
13. *Code of Practice for the Safety, Health and Welfare at Work ( Chemical Agents ) Regulations, 1994* ( S.I. No. 445 of 1994 ). Stationery Office, Dublin.
14. Peavey, Howard S., Rowe, Donald R., and Tchobanoglous, George ( 1986 ) *Environmental Engineering* Mc Graw - Hill, New York.
15. Engineering School UCD (1972 ). *Course Notes - Water Quality Management. Separation of Suspended Solids 5 - Filtration*.
16. Flanagan, P.J., *Parameters of Water Quality - Interpretation and Standards*. Second Edition. Environmental Research Unit, Dublin.
17. Mc Evatt, Editor, Third Edition, 1973. *Metric Guide 1*. An Foras Forbartha, Dublin.

18. Fair, G. M., and Geyer, J.C. (1959) *Water Supply and Waste Water Disposal* John Wiley & Sons Inc., New York.
19. Huisman, L. & Wood, W.E. (1974) *Slow Sand Filtration*, Geneva, World Health Organisation.
20. American Waterworks Association . *Water Quality and Treatment : A Handbook of Community Water Supplies* Fourth Edition. Quoted in Reference (1) above. A.W.W.A., 6666 W. Quincy Ave., Denver, CO 80235.
21. Stevenson, D.G., *The Specification of Filtering Materials for Rapid Gravity Filtration* in Journal of Institution of Water and Environmental Management, Volume 8, October 1994.
22. British Water and Effluent Association ,1993. *Standard for the Specification, Approval and Testing of Granular Filtering Materials* EWA:P.18.93

## USER COMMENT FORM

NOTE: Completed comments to be forwarded to: The Environmental Management and Planning Division,  
Environmental Protection Agency, P.O. Box 3000, Johnstown Castle Estate, Wexford

Document Title: **Water Treatment Manuals – Coagulation, Flocculation & Clarification**

---

CONTENTS:

---

STYLE:

---

INFORMATION:

---

SUGGESTIONS FOR FUTURE EDITIONS:

---

NAME..... ORGANISATION.....

ADDRESS.....

DATE ..... PHONE ..... FAX.....









































